



**THE DATASHEET OF
9P935AGLFT**



DDR I/DDR II Phase Lock Loop Zero Delay Buffer

ICS9P935

Description

DDR I/DDR II Zero Delay Clock Buffer

Output Features

- Low skew, low jitter PLL clock driver
- Max frequency supported = 400MHz (DDR II 800)
- I²C for functional and output control
- Feedback pins for input to output synchronization
- Spread Spectrum tolerant inputs
- Programmable skew through SMBus
- Frequency defect control through SMBus
- Individual output control programmable through SMBus

Key Specifications

- CYCLE - CYCLE jitter: <100ps
- OUTPUT - OUTPUT skew: <100ps
- DUTY CYCLE: 48% - 52%
- 28-pin SSOP package
- Available in RoHS compliant packaging
- Operates @ 2.5V or 1.8V

Pin Configuration

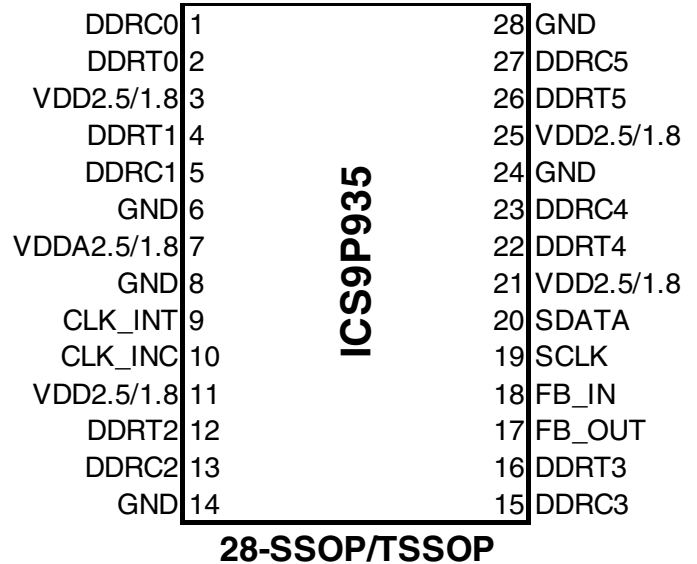

Functional Block Diagram

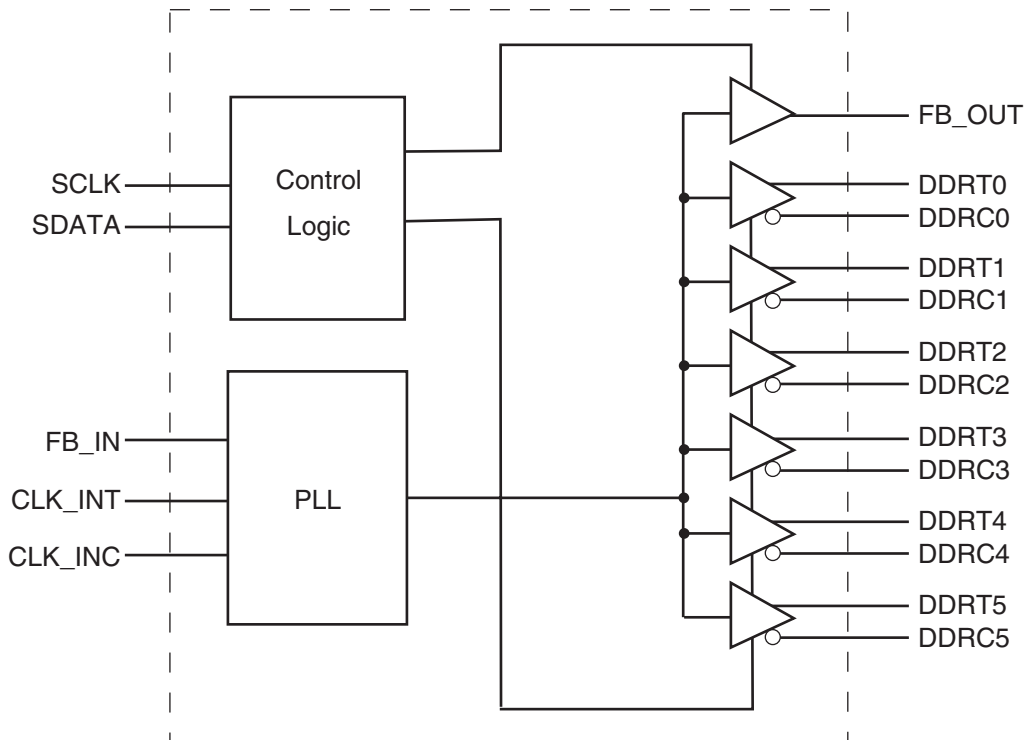

Pin Description

Pin#	Pin Name	Type	Pin Description
1	DDRC0	OUT	"Complementary" Clock of differential pair output.
2	DDRT0	OUT	"True" Clock of differential pair output.
3	VDD2.5/1.8	PWR	Power supply, nominal 2.5V or 1.8V
4	DDRT1	OUT	"True" Clock of differential pair output.
5	DDRC1	OUT	"Complementary" Clock of differential pair output.
6	GND	PWR	Ground pin.
7	VDDA2.5/1.8	PWR	Output power supply, nominal 2.5V or 1.8V
8	GND	PWR	Ground pin.
9	CLK_INT	IN	"True" reference clock input.
10	CLK_INC	IN	"Complementary" reference clock input.
11	VDD2.5/1.8	PWR	Power supply, nominal 2.5V or 1.8V
12	DDRT2	OUT	"True" Clock of differential pair output.
13	DDRC2	OUT	"Complementary" Clock of differential pair output.
14	GND	PWR	Ground pin.
15	DDRC3	OUT	"Complementary" Clock of differential pair output.
16	DDRT3	OUT	"True" Clock of differential pair output.
17	FB_OUT	OUT	Feedback output, dedicated for external feedback.
18	FB_IN	IN	Single-ended feedback input, provides feedback signal to internal PLL to eliminate phase error with the input clock.
19	SCLK	IN	Clock pin of SMBus circuitry, 3.3V tolerant.
20	SDATA	I/O	Data pin for SMBus circuitry, 3.3V tolerant.
21	VDD2.5/1.8	PWR	Power supply, nominal 2.5V or 1.8V
22	DDRT4	OUT	"True" Clock of differential pair output.
23	DDRC4	OUT	"Complementary" Clock of differential pair output.
24	GND	PWR	Ground pin.
25	VDD2.5/1.8	PWR	Power supply, nominal 2.5V or 1.8V
26	DDRT5	OUT	"True" Clock of differential pair output.
27	DDRC5	OUT	"Complementary" Clock of differential pair output.
28	GND	PWR	Ground pin.

Absolute Max

Supply Voltage	-0.5V to 2.7V
Logic Inputs	GND -0.5 V to V _{DD} +0.5 V
Ambient Operating Temperature	0°C to +70°C
Case Temperature	115°C
Storage Temperature	-65°C to +150°C

Stresses above those listed under *Absolute Maximum Ratings* may cause permanent damage to the device. These ratings are stress specifications only and functional operation of the device at these or any other conditions above those listed in the operational sections of the specifications is not implied. Exposure to absolute maximum rating conditions for extended periods may affect product reliability.

Electrical Characteristics - Input/Supply/Common Output Parameters

T_A = 0 - 70°C; Supply Voltage AVDD, VDD = 1.8 V +/- 0.1V (unless otherwise stated)

PARAMETER	SYMBOL	CONDITIONS	MIN	TYP	MAX	UNITS
Input High Current	I _{IH}	V _I = V _{DD} or GND			±250	μA
Input Low Current	I _{IL}	V _I = V _{DD} or GND			±10	μA
Output Disabled Low Current	I _{ODL}	OE = L, V _{ODL} = 100mV	100			μA
Operating Supply Current	I _{DD1.8}	C _L = 0pf @ 100MHz			300	mA
	I _{DDL}	C _L = 0pf			500	μA
Input Clamp Voltage	V _{IK}	V _{DDQ} = 1.8V I _{in} = -18mA			-1.2	V
High-level output voltage	V _{OH}	I _{OH} = -100μA	V _{DD} -0.2			V
		I _{OH} = -9mA	1.1			V
Low-level output voltage	V _{OL}	I _{OL} =100μA			0.1	V
		I _{OL} =9mA			0.6	V
Input Capacitance ¹	C _{IN}	V _I = GND or V _{DD}	2		3	pF
Output Capacitance ¹	C _{OUT}	V _{OUT} = GND or V _{DD}	2		3	pF

Recommended Operating Condition (see note1)

$T_A = 0 - 70^\circ\text{C}$; Supply Voltage AVDD, VDD = 1.8 V +/- 0.1V (unless otherwise stated)

PARAMETER	SYMBOL	CONDITIONS	MIN	TYP	MAX	UNITS
Supply Voltage	V_{DDQ}, A_{VDD}		1.7	1.8	1.9	V
Low level input voltage	V_{IL}	CLK_INT, CLK_INC, FB_IN			$0.35 \times V_{DD}$	V
High level input voltage	V_{IH}	CLK_INT, CLK_INC, FB_IN	$0.65 \times V_{DD}$			V
DC input signal voltage (note 2)	V_{IN}		-0.3		$V_{DD} + 0.3$	V
DC input signal voltage swing	$V_{IN-Diff}$	CLK_INT, CLK_INC	GND - 0.3	1.5	$V_{DD} + 0.3$	V
Differential input signal voltage (note 3)	V_{ID}	DC - CLK_INT, CLK_INC, FB_IN	0.3		$V_{DD} + 0.4$	V
		AC - CLK_INT, CLK_INC, FB_IN	0.6		$V_{DD} + 0.4$	V
Output differential cross-voltage (note 4)	V_{OX}		$V_{DD} / 2 - 0.1$		$V_{DD} / 2 + 0.1$	V
Input differential cross-voltage (note 4)	V_{IX}		$V_{DD}/2 - 0.15$	$V_{DD}/2$	$V_{DD} / 2 + 0.15$	V
High level output current	I_{OH}				-9	mA
Low level output current	I_{OL}				9	mA
High Impedance Output Current	I_{OZ}	$V_{DD}=1.9V, V_{OUT}=V_{DD}$ or GND			± 10	mA
Operating free-air temperature	T_A		0		70	$^\circ\text{C}$

Notes:

1. Unused inputs must be held high or low to prevent them from floating.
2. DC input signal voltage specifies the allowable DC execution of differential input.
3. Differential inputs signal voltages specifies the differential voltage [VTR-VCP] required for switching, where VTR is the true input level and VCP is the complementary input level.
4. Differential cross-point voltage is expected to track variations of V_{DD} and is the voltage at which the differential signal must be crossing.

Timing Requirements

$T_A = 0 - 70^\circ\text{C}$ Supply Voltage AVDD, VDD = 1.8 V +/- 0.1V (unless otherwise stated)

PARAMETER	SYMBOL	CONDITIONS	MIN	MAX	UNITS
Max clock frequency	freq _{op}	1.8V±0.1V @ 25°C	125	500	MHz
Application Frequency Range	freq _{App}	1.8V±0.1V @ 25°C	160	400	MHz
Input clock duty cycle	d _{tin}		40	60	%
CLK stabilization	T _{STAB}			15	µs

Switching Characteristics¹

PARAMETER	SYMBOL	CONDITION	MIN	TYP	MAX	UNITS
Output enable time	t _{en}	OE to any output			8	ns
Output disable time	t _{dis}	OE to any output			8	ns
Period jitter	t _{jit(per)}		-40		40	ps
Half-period jitter	t _{jit(hper)}		-75		75	ps
Input slew rate	SLr1(i)	Input Clock	1	2.5	4	v/ns
		Output Enable (OE), (OS)	0.5			v/ns
Output clock slew rate	SLr1(o)		1.5	2.5	3	v/ns
Cycle-to-cycle period jitter	t _{jit(cc+)}		0		40	ps
	t _{jit(cc-)}		0		-40	ps
Dynamic Phase Offset	t _{()dyn}		-50		50	ps
Phase error	t _(phase error) ²		-50	0	50	ps
Output to Output Skew	t _{skew}				40	ps
SSC modulation frequency			30.00		33	kHz
SSC clock input frequency deviation			0.00		-0.50	%

Notes:

1. Refers to transition on noninverting output in PLL bypass mode.
2. While the pulse skew is almost constant over frequency, the duty cycle error increases at higher frequencies. This is due to the formula: duty cycle=t_{WH}/t_C, where the cycle (t_C) decreases as the frequency goes up.
3. Switching characteristics guaranteed for application frequency range.
4. Static phase offset shifted by design.

Electrical Characteristics - Input/Supply/Common Output Parameters

$T_A = 0 - 70^\circ\text{C}$; Supply Voltage $A_{V_{DD}}$, $V_{DD} = 2.5\text{V} \pm 0.2\text{V}$

PARAMETER	SYMBOL	CONDITIONS	MIN	TYP	MAX	UNITS
Input High Current	I_{IH}	$V_I = V_{DD}$ or GND	5			μA
Input Low Current	I_{IL}	$V_I = V_{DD}$ or GND			5	μA
Operating Supply Current	$I_{DD2.5}$	$C_L = 0\text{pf}$ @ 200MHz		250		mA
	I_{DDPD}	$C_L = 0\text{pf}$			100	μA
Output High Current	I_{OH}	$V_{DD} = 2.3\text{V}$, $V_{OUT} = 1\text{V}$	-18	-32		mA
Output Low Current	I_{OL}	$V_{DD} = 2.3\text{V}$, $V_{OUT} = 1.2\text{V}$	26	35		mA
High Impedance Output Current	I_{OZ}	$V_{DD}=2.7\text{V}$, $V_{out}=V_{DD}$ or GND			± 10	mA
Input Clamp Voltage	V_{IK}	$V_{DDQ} = 2.3\text{V}$ $I_{in} = -18\text{mA}$			-1.2	V
High-level output voltage	V_{OH}	$V_{DD} = \text{min to max}$, $I_{OH} = -1 \text{ mA}$	$V_{DDQ} - 0.1$			V
		$V_{DDQ} = 2.3\text{V}$, $I_{OH} = -12 \text{ mA}$	1.7			V
Low-level output voltage	V_{OL}	$V_{DD} = \text{min to max}$ $I_{OL}=1 \text{ mA}$			0.1	V
		$V_{DDQ} = 2.3\text{V}$ $I_{OH}=12 \text{ mA}$			0.6	V
Input Capacitance ¹	C_{IN}	$V_I = \text{GND}$ or V_{DD}		3		pF
Output Capacitance ¹	C_{OUT}	$V_{OUT} = \text{GND}$ or V_{DD}		3		pF

Recommended Operating Condition (see note 1)

$T_A = 0 - 70^\circ\text{C}$; Supply Voltage AVDD, VDD = 2.5 V +/- 0.2V (unless otherwise stated)

PARAMETER	SYMBOL	CONDITIONS	MIN	TYP	MAX	UNITS
Supply Voltage	V_{DD}, A_{VDD}		2.3	2.5	2.7	V
Low level input voltage	V_{IL}	DDRT,DDRC		0.4	$V_{DD}/2 - 0.18$	V
High level input voltage	V_{IH}	DDRT,DDRC	$V_{DD}/2 + 0.18$	2.1		V
DC input signal voltage (note 2)	V_{IN}		-0.3		$V_{DD} + 0.3$	V
Differential input signal voltage (note 3)	V_{ID}	DC - DDRT	0.36		$V_{DD} + 0.6$	V
		AC - DDRT	0.7		$V_{DD} + 0.6$	V
Output differential cross-voltage (note 4)	V_{OX}		$V_{DD}/2 - 0.15$		$V_{DD}/2 + 0.15$	V
Input differential cross-voltage (note 4)	V_{IX}		$V_{DD}/2 - 0.2$	$V_{DD}/2$	$V_{DD}/2 + 0.2$	V
High level output current	I_{OH}				-30	mA
Low level output current	I_{OL}				-30	mA
Operating free-air temperature	T_A		0		85	$^\circ\text{C}$

Notes:

1. Unused inputs must be held high or low to prevent them from floating.
2. DC input signal voltage specifies the allowable DC execution of differential input.
3. Differential inputs signal voltages specifies the differential voltage [VTR-VCP] required for switching, where VT is the true input level and VCP is the complementary input level.
4. Differential cross-point voltage is expected to track variations of V_{DD} and is the voltage at which the differential signal must be crossing.

Timing Requirements

$T_A = 0 - 70^\circ\text{C}$; Supply Voltage A_{VDD} , $V_{DD} = 2.5\text{ V} \pm 0.2\text{V}$ (unless otherwise stated)

PARAMETER	SYMBOL	CONDITIONS	MIN	MAX	UNITS
Max clock frequency	freq_{op}	$2.5\text{V} \pm 0.2\text{V}$ @ 25°C	45	600	MHz
Application Frequency Range	freq_{App}	$2.5\text{V} \pm 0.2\text{V}$ @ 25°C	95	233	MHz
Input clock duty cycle	d_{tin}		40	60	%
CLK stabilization	T_{STAB}			15	μs

Switching Characteristics³

PARAMETER	SYMBOL	CONDITION	MIN	TYP	MAX	UNITS
Low-to high level propagation delay time	t_{PLH}^1	BUF_IN to any output		3.5		ns
High-to low level propagation delay time	t_{PLL}^1	BUF_IN to any output		3.5		ns
Period jitter	$T_{\text{jit(per)}}$	100MHz to 200MHz	-30		30	ps
Half-period jitter	$t(\text{jit_hper})$	100MHz to 200MHz	-100		100	ps
Input clock slew rate	$t_{\text{sl(i)}}$		1		4	V/ns
Output clock slew rate	$t_{\text{sl(o)}}$		1		2	V/ns
Cycle to Cycle Jitter ¹	$T_{\text{cyc}} - T_{\text{cyc}}$	100MHz to 200MHz	-50		50	ps
Static Phase Offset	$t_{\text{(static phase offset)}}^4$		-50	0	50	ps
Output to Output Skew	T_{skew}				40	ps

Notes:

- Refers to transition on noninverting output in PLL bypass mode.
- While the pulse skew is almost constant over frequency, the duty cycle error increases at higher frequencies. This is due to the formula: $\text{duty cycle} = t_{\text{wH}}/t_{\text{c}}$, where the cycle (t_{c}) decreases as the frequency goes up.
- Switching characteristics guaranteed for application frequency range.
- Static phase offset shifted by design.

General I²C serial interface information for the ICS9P935

How to Write:

- Controller (host) sends a start bit.
- Controller (host) sends the write address D4_(H)
- ICS clock will **acknowledge**
- Controller (host) sends the beginning byte location = N
- ICS clock will **acknowledge**
- Controller (host) sends the data byte count = X
- ICS clock will **acknowledge**
- Controller (host) starts sending **Byte N through Byte N + X - 1**
(see Note 2)
- ICS clock will **acknowledge** each byte **one at a time**
- Controller (host) sends a Stop bit

How to Read:

- Controller (host) will send start bit.
- Controller (host) sends the write address D4_(H)
- ICS clock will **acknowledge**
- Controller (host) sends the beginning byte location = N
- ICS clock will **acknowledge**
- Controller (host) will send a separate start bit.
- Controller (host) sends the read address D5_(H)
- ICS clock will **acknowledge**
- ICS clock will send the data byte count = X
- ICS clock sends **Byte N + X - 1**
- ICS clock sends **Byte 0 through byte X (if X_(H) was written to byte 8).**
- Controller (host) will need to acknowledge each byte
- Controller (host) will send a not acknowledge bit
- Controller (host) will send a stop bit

Index Block Write Operation		
Controller (Host)		ICS (Slave/Receiver)
T	starT bit	
Slave Address D4 _(H)		
WR	WRite	
		ACK
Beginning Byte = N		
		ACK
Data Byte Count = X		
		ACK
Beginning Byte N		X Byte
○		
○		
○		
○		
Byte N + X - 1		
		ACK
P	stoP bit	

Index Block Read Operation		
Controller (Host)		ICS (Slave/Receiver)
T	starT bit	
Slave Address D4 _(H)		
WR	WRite	
		ACK
Beginning Byte = N		
		ACK
RT	Repeat starT	
Slave Address D5 _(H)		
RD	ReaD	
		ACK
		Data Byte Count = X
ACK		
		Beginning Byte N
ACK		X Byte
○		
○		
○		
○		
		Byte N + X - 1
N	Not acknowledge	
P	stoP bit	

Notes:

1. The IDT clock generator is a slave/receiver, I²C component. It can read back the data stored in the latches for verification.
Read-Back will support SMBus block read protocol.
2. The data transfer rate supported by this clock generator is 100K bits/sec or less (standard mode)
3. The input is operating at 3.3V logic levels.
4. The data byte format is 8 bit bytes.
5. To simplify the clock generator I²C interface, the protocol is set to use only "**Block-Writes**" from the controller. The bytes must be accessed in sequential order from lowest to highest byte with the ability to stop after any complete byte has been transferred. The Command code and Byte count shown above must be sent, The data is loaded until a Stop sequence is issued.
6. At power-on, all registers are set to a default condition, as shown.

I²C Table: Output Control Register

Byte 6	Pin #	Name	Control Function	Type	0	1	PWD
Bit 7	-	Freq Detect	Low Frequency Detect PLL OFF Control	RW	OFF	ON	1
Bit 6	-	FB_IN/OUT	FB_OUT Control	RW	Disable	Enable	1
Bit 5	-	DDR_T5/C5	Output Control	RW	Disable	Enable	1
Bit 4	-	DDR_T4/C4	Output Control	RW	Disable	Enable	1
Bit 3	-	DDR_T3/C3	Output Control	RW	Disable	Enable	1
Bit 2	-	DDR_T2/C2	Output Control	RW	Disable	Enable	1
Bit 1	-	DDR_T1/C1	Output Control	RW	Disable	Enable	1
Bit 0	-	DDR_T0/C0	Output Control	RW	Disable	Enable	1

I²C Table: Group Skew Control Register

Byte 8	Pin #	Name	Control Function	Type	0	1	PWD
Bit 7	-	DDR Skw3	CLKIN to DDR Skew Control	RW	See Table 1: 7-Step Skew Programming Table		0
Bit 6	-	DDR Skw2		RW			0
Bit 5	-	DDR Skw1		RW			0
Bit 4	-	DDR Skw0		RW			0
Bit 3	-	DDR Skw3	CLKIN to DDR Skew Control	RW	See Table 2: 7-Step Skew Programming Table		0
Bit 2	-	DDR Skw2		RW			0
Bit 1	-	DDR Skw1		RW			0
Bit 0	-	DDR Skw0		RW			0

I²C Table: Revision ID and Vendor ID Register

Byte 10	Pin #	Name	Control Function	Type	0	1	PWD
Bit 7	-	Revision_ID bit 3	Rev ID	RW	-	-	X
Bit 6	-	Revision_ID bit 2		RW	-	-	X
Bit 5	-	Revision_ID bit 1		RW	-	-	X
Bit 4	-	Revision_ID bit 0		RW	-	-	X
Bit 3	-	Vendor_ID bit3	Vendor ID	RW	-	-	0
Bit 2	-	Vendor_ID bit2		RW	-	-	0
Bit 1	-	Vendor_ID bit1		RW	-	-	0
Bit 0	-	Vendor_ID bit0		RW	-	-	1

I²C Table: Byte Count Register

Byte 15	Pin #	Name	Control Function	Type	0	1	PWD
Bit 7	-	BC7	Byte Count Programming b(7:0)	RW	Writing to this register will configure how many bytes will be read back, default is 0F = 15 bytes		0
Bit 6	-	BC6		RW			0
Bit 5	-	BC5		RW			0
Bit 4	-	BC4		RW			0
Bit 3	-	BC3		RW			1
Bit 2	-	BC2		RW			1
Bit 1	-	BC1		RW			1
Bit 0	-	BC0		RW			1

I²C Table: All other I²C Registers are Reserved

Table 1: 7-Steps Skew Programming Table

7 Step	11	10	01	00	LSB
11	600 ps	500 ps	400 ps	300 ps	
10	N/A	N/A	N/A	200 ps	
01	N/A	N/A	N/A	100 ps	
00	N/A	N/A	N/A	0.0 ps	
MSB					

Table 2: 7-Steps Skew Programming Table

7 Step	11	10	01	00	LSB
11	-600 ps	-500 ps	-400 ps	-300 ps	
10	N/A	N/A	N/A	-200 ps	
01	N/A	N/A	N/A	-100 ps	
00	N/A	N/A	N/A	0.0 ps	
MSB					

ICS9P935
DDR I/DDR II Phase Lock Loop Zero Delay Buffer

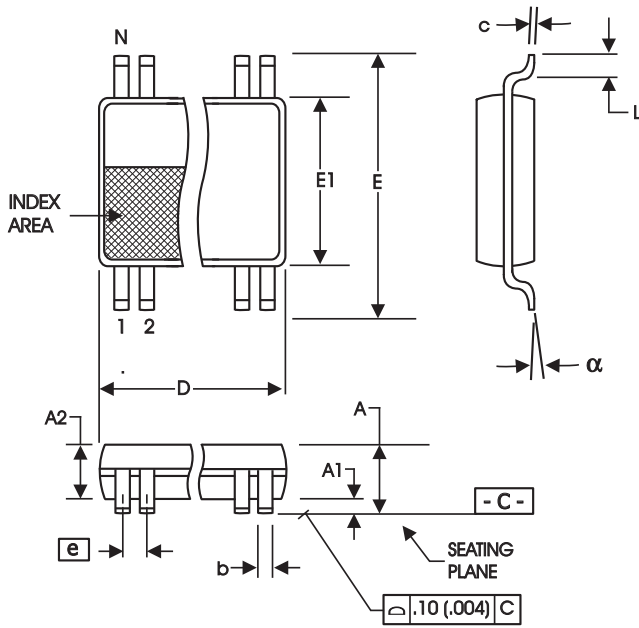

209 mil SSOP

SYMBOL	In Millimeters		In Inches	
	COMMON DIMENSIONS	COMMON DIMENSIONS	COMMON DIMENSIONS	COMMON DIMENSIONS
A	--	2.00	--	.079
A1	0.05	--	.002	--
A2	1.65	1.85	.065	.073
b	0.22	0.38	.009	.015
c	0.09	0.25	.0035	.010
D	SEE VARIATIONS		SEE VARIATIONS	
E	7.40	8.20	.291	.323
E1	5.00	5.60	.197	.220
e	0.65 BASIC		0.0256 BASIC	
L	0.55	0.95	.022	.037
N	SEE VARIATIONS		SEE VARIATIONS	
alpha	0°	8°	0°	8°

VARIATIONS

N	D mm.		D (inch)	
	MIN	MAX	MIN	MAX
28	9.90	10.50	.390	.413

Reference Doc.: JEDEC Publication 95, MO-150
 10-0033

Ordering Information

ICS9P935yFLF-T

Example:

ICS XXXX y F LF-T

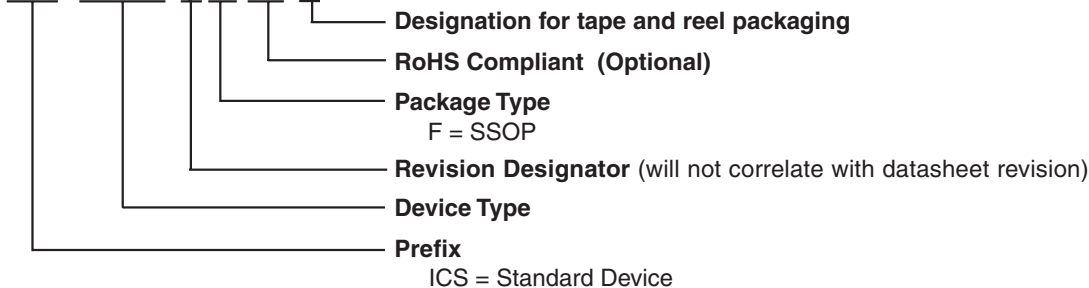

ICS9P935
DDR I/DDR II Phase Lock Loop Zero Delay Buffer

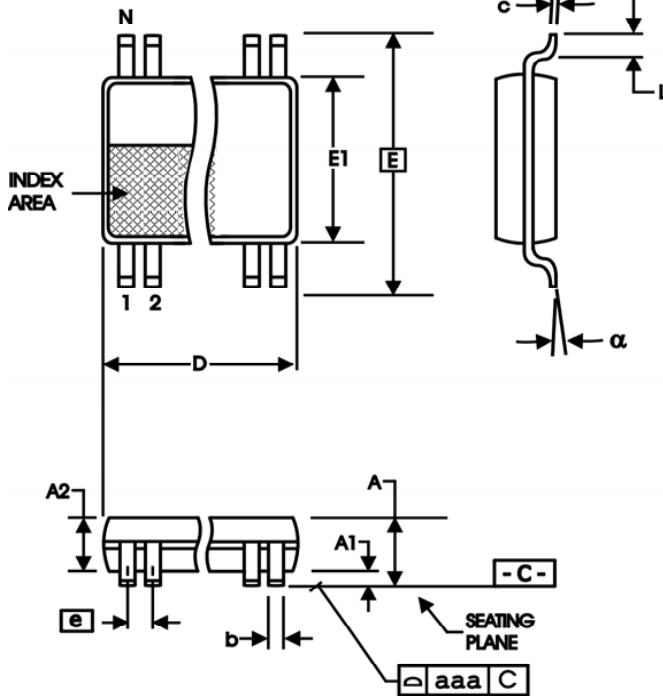

4.40 mm. Body, 0.65 mm. Pitch TSSOP
(173 mil) (25.6 mil)

SYMBOL	In Millimeters COMMON DIMENSIONS		In Inches COMMON DIMENSIONS	
	MIN	MAX	MIN	MAX
A	--	1.20	--	.047
A1	0.05	0.15	.002	.006
A2	0.80	1.05	.032	.041
b	0.19	0.30	.007	.012
c	0.09	0.20	.0035	.008
D	SEE VARIATIONS		SEE VARIATIONS	
E	6.40 BASIC		0.252 BASIC	
E1	4.30	4.50	.169	.177
e	0.65 BASIC		0.0256 BASIC	
L	0.45	0.75	.018	.030
N	SEE VARIATIONS		SEE VARIATIONS	
alpha	0°	8°	0°	8°
aaa	--	0.10	--	.004

VARIATIONS

N	D mm.		D (inch)	
	MIN	MAX	MIN	MAX
28	9.60	9.80	.378	.386

Reference Doc.: JEDEC Publication 95, MO-153

10-0035

Ordering Information

ICS9P935yGLF-T

Example:

ICS XXXX y G LF-T

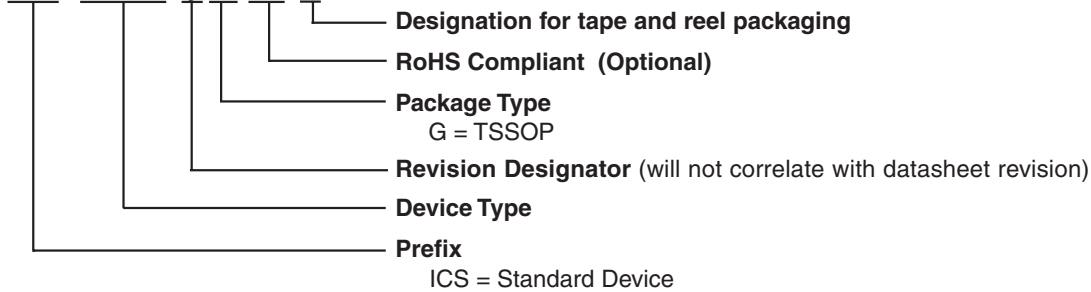

Revision History

Rev.	Issue Date	Description	Page #
A	2/8/2007	Final Release.	-
B	6/4/2007	Fixed various typos.	-
C	6/14/2007	Added TSSOP Ordering Information.	12
D	6/20/2007	1. Updated Output Features: Max Frequency Supported. 2. Updated DDRI/DDRII Max Clock Frequency.	1 5, 8
E	8/16/2007	1. Updated Supply Voltage. 2. Updated Input High/Low Current Max.	3
F	9/5/2007	Updated Electrical Specifications.	3-5
G	11/19/2007	Updated Serial Interface Information.	9
H	12/1/2008	Updated Pin Description.	2

IMPORTANT NOTICE AND DISCLAIMER

RENESAS ELECTRONICS CORPORATION AND ITS SUBSIDIARIES (“RENESAS”) PROVIDES TECHNICAL SPECIFICATIONS AND RELIABILITY DATA (INCLUDING DATASHEETS), DESIGN RESOURCES (INCLUDING REFERENCE DESIGNS), APPLICATION OR OTHER DESIGN ADVICE, WEB TOOLS, SAFETY INFORMATION, AND OTHER RESOURCES “AS IS” AND WITH ALL FAULTS, AND DISCLAIMS ALL WARRANTIES, EXPRESS OR IMPLIED, INCLUDING, WITHOUT LIMITATION, ANY IMPLIED WARRANTIES OF MERCHANTABILITY, FITNESS FOR A PARTICULAR PURPOSE, OR NON-INFRINGEMENT OF THIRD-PARTY INTELLECTUAL PROPERTY RIGHTS.

These resources are intended for developers who are designing with Renesas products. You are solely responsible for (1) selecting the appropriate products for your application, (2) designing, validating, and testing your application, and (3) ensuring your application meets applicable standards, and any other safety, security, or other requirements. These resources are subject to change without notice. Renesas grants you permission to use these resources only to develop an application that uses Renesas products. Other reproduction or use of these resources is strictly prohibited. No license is granted to any other Renesas intellectual property or to any third-party intellectual property. Renesas disclaims responsibility for, and you will fully indemnify Renesas and its representatives against, any claims, damages, costs, losses, or liabilities arising from your use of these resources. Renesas' products are provided only subject to Renesas' Terms and Conditions of Sale or other applicable terms agreed to in writing. No use of any Renesas resources expands or otherwise alters any applicable warranties or warranty disclaimers for these products.

(Disclaimer Rev.1.01 Jan 2024)

Corporate Headquarters

TOYOSU FORESIA, 3-2-24 Toyosu,
Koto-ku, Tokyo 135-0061, Japan
www.renesas.com

Trademarks

Renesas and the Renesas logo are trademarks of Renesas Electronics Corporation. All trademarks and registered trademarks are the property of their respective owners.

Contact Information

For further information on a product, technology, the most up-to-date version of a document, or your nearest sales office, please visit www.renesas.com/contact-us/.

Looking for pricing, stock, or lifecycle information?

Click below to explore more details on WIN SOURCE:

-  [View 9P935AGLFT on WIN SOURCE](#)
-  [Renesas Electronics America](#) Information

Optimize Your Supply Chain with WIN SOURCE Solutions

-  Global Sourcing Solution
-  Obsolete Management
-  Cost Control Management
-  Shortage Management
-  Alternative Solution
-  Excess Inventory Management