

**WIN***SOURCE*  
ELECTRONICS

**THE DATASHEET OF**

**0878325923**

[www.win-source.net](http://www.win-source.net)



0086-755-83957316

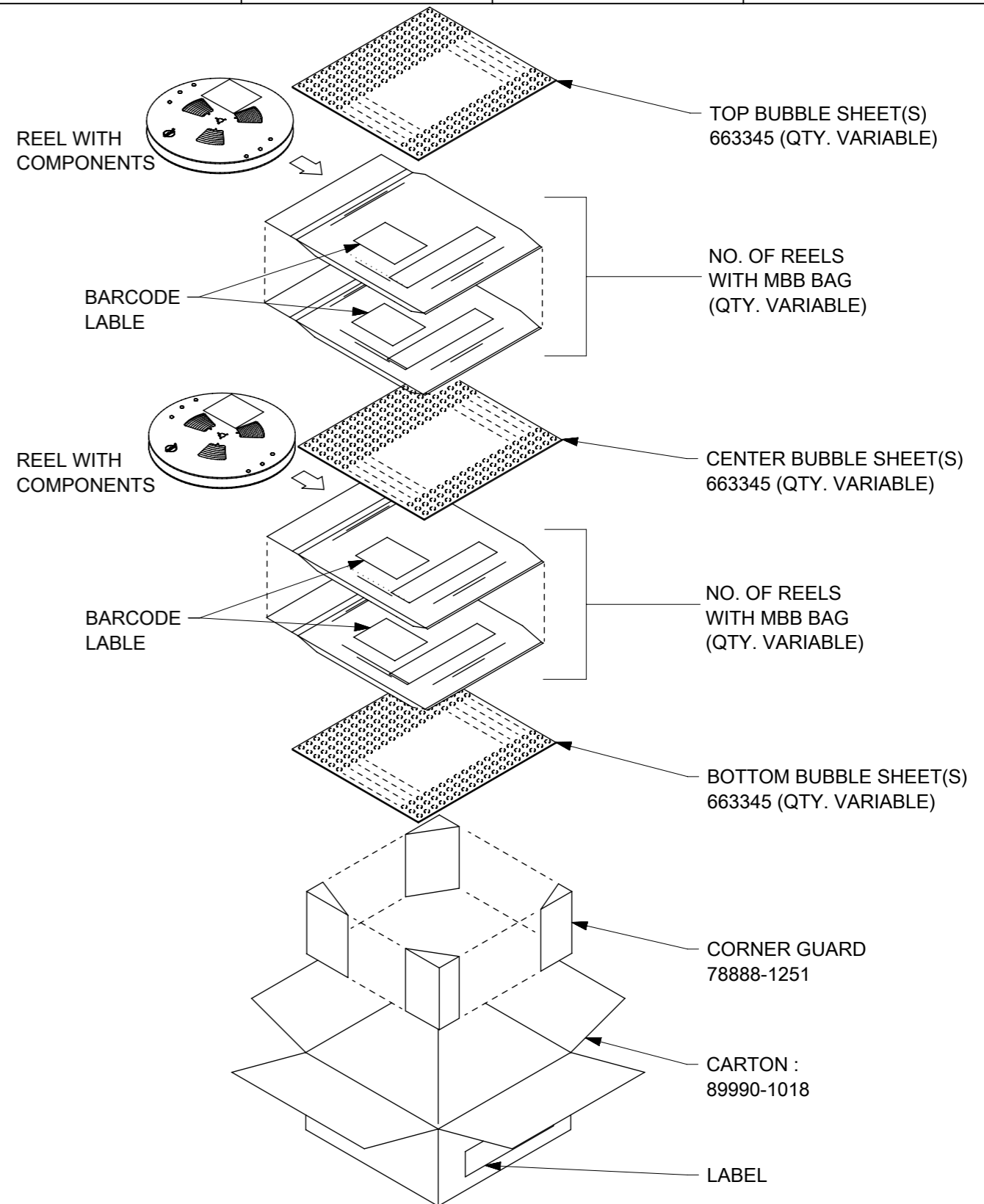
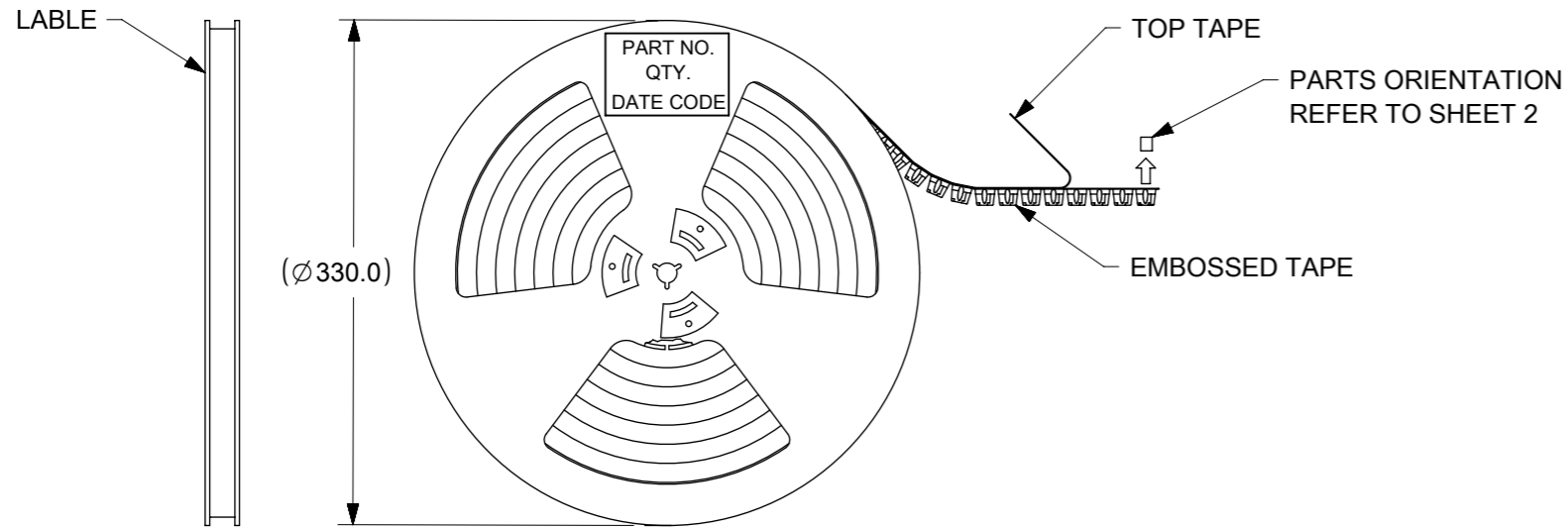

- NOTES:
1. ALL REQUIREMENTS FOR TAPING SURFACE MOUNT COMPONENTS IS AS PER EIA-481 STANDARD.
  3. THE TOP COVER TAPE SHALL BE CLEAR ONLY, AND SHALL NOT EXTEND OVER THE EDGES OF THE CARRIER TAPE OR COVER ANY PART OF THE SPROCKET HOLES.
  4. THE TOP COVER TAPE MUST BE SECURELY ATTACHED TO THE EMBOSSSED CARRIER TAPE BY USE OF HEAT.
  5. EACH REEL SHALL HAVE A LABEL AFFIXED TO IT WITH THE FOLLOWING INFORMATION:  
PART NO., QUANTITY, DATE CODE
  6. EACH REEL MUST BE PACKED IN AN MBB BAG.
  7. TAPE SPLICES ARE NOT PERMITTED.

THIS DRAWING CONTAINS INFORMATION THAT IS PROPRIETARY TO MOLEX ELECTRONIC TECHNOLOGIES, LLC AND SHOULD NOT BE USED WITHOUT WRITTEN PERMISSION													
QUALITY SYMBOLS ▽A = 0 ▽E = 0 ▽D = 0 ▼ = 0 ▽C = 0 ⊠ = 0 ■ = 0 ▽ = 0	RE-MASTERED IN ELECTR EC NO: 119993 DRWN: MUM CHK'D: GMENARLY REV APPR: KHLIM	GENERAL TOLERANCES (UNLESS SPECIFIED)		DIMENSION UNITS		SCALE							
				MM	INCH	MM	NTS						
				4 PLACES ±	±	DRWN BY	DATE	PACKAGING SPECIFICATION FOR 87832 IN T&R  PACKAGING DESIGN DRAWING					
				3 PLACES ±	±	ATSEE	2015/08/24						
				2 PLACES ±	±	CHK'D BY	DATE						
				1 PLACES ±	±	CGOH	2015/08/24	PACKAGING DESIGN DRAWING SERIES: 87832 MATERIAL NUMBER: SEE TABLE CUSTOMER: GENERAL MARKET					
				0 PLACES ±	±	APPR BY	DATE						
				ANGULAR TOL = 1.0		KHLIM	2017/05/26	DRAWING SIZE: A3		THIRD ANGLE PROJECTION		DOCUMENT NUMBER: PK-87832-300	
				DRAFT WHERE APPLICABLE MUST REMAIN WITHIN DIMENSIONS						DOC TYPE: PDD		DOC PART: 001 SHEET NUMBER: 1 OF 12	

# TAPE AND REEL PACKAGING SPECIFICATIONS

## EMBOSSED TAPE WIDTH FROM 16.00mm TO 24.00mm

8 CKT USE FOR ILLUSTRATION ONLY.

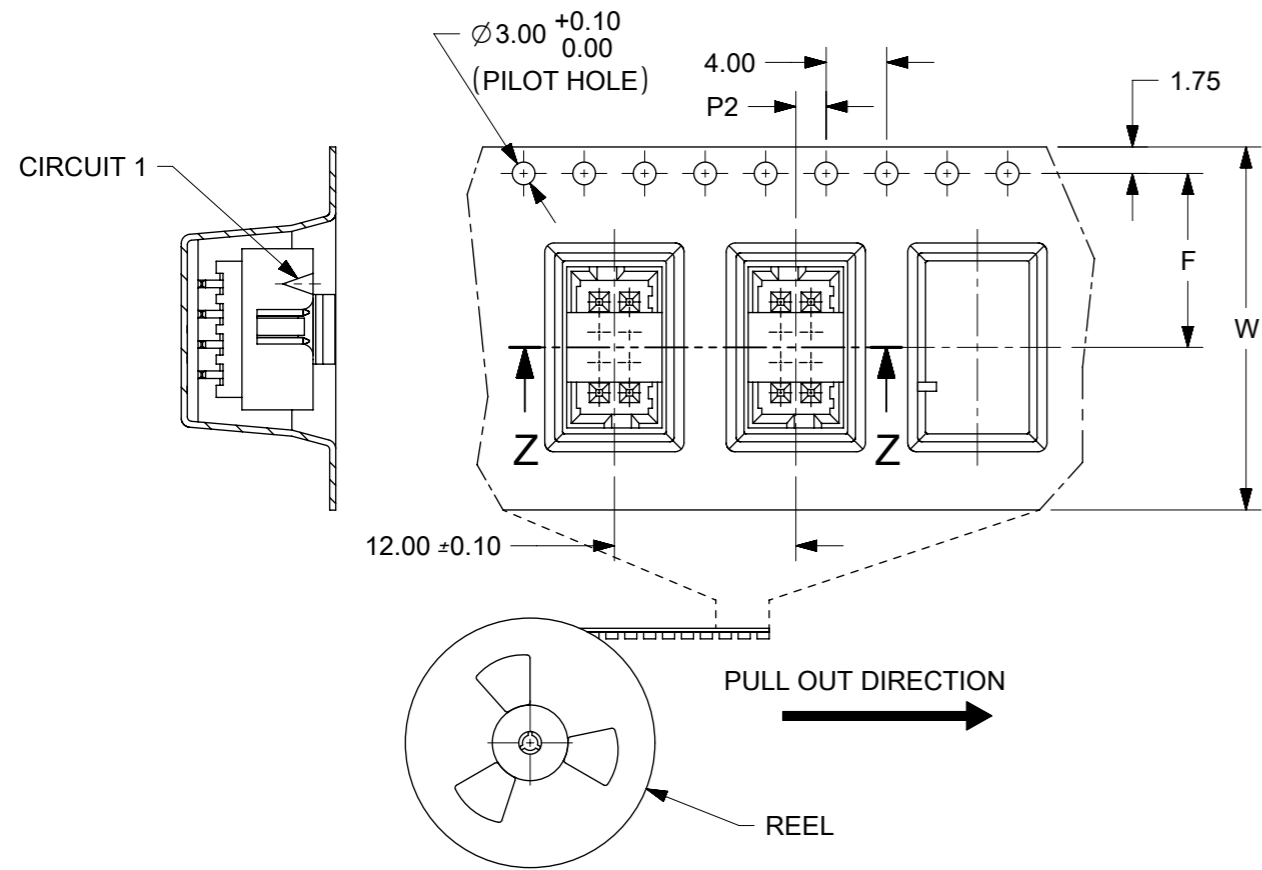

## EMBOSSED TAPE WIDTH FROM 44.00mm TO 72.00mm

24 CKT USE FOR ILLUSTRATION ONLY.

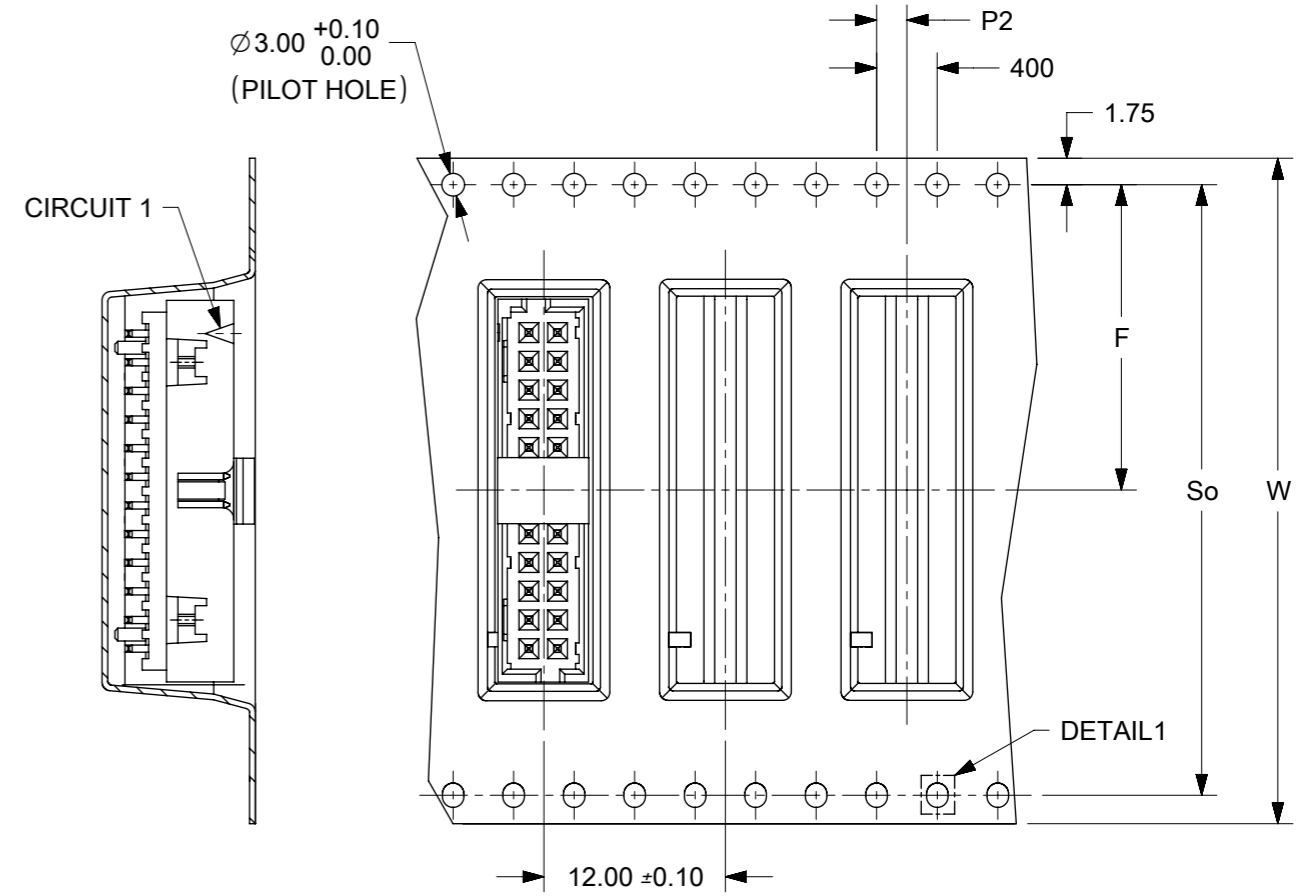

### NOTES:

1. LEADER AND TRAILER TAPE

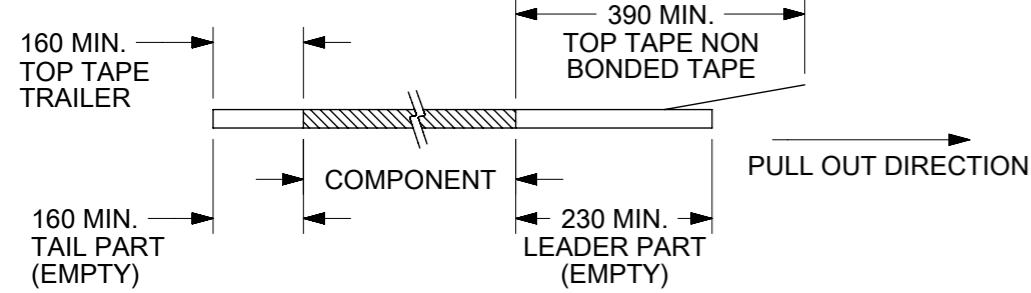

2. PEELING OFF FORCE OF THE TOP TAPE: 10 - 130gf.

(PEELING DIRECTION AS SHOWN IN FOLLOWING FIGURE)

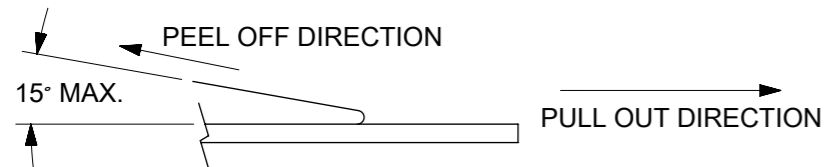

3. TAPE AND REEL SPECIFICATION IS AS PER EIA-481.

4. TAPE AND REEL QUANTITY : SEE TABLE

5. THE TAPE IS TREATED FOR ANTI-STATIC.

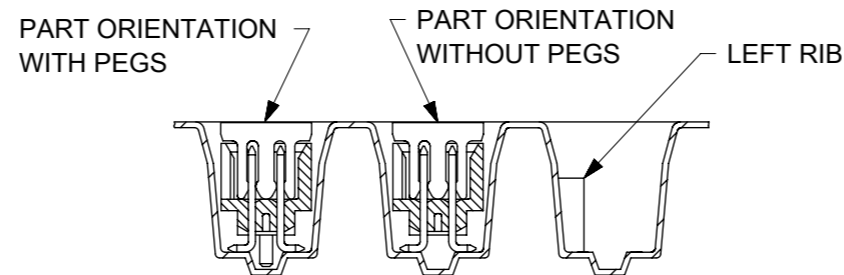

SECTION Z-Z

W	F	So	P2
16	7.50±0.10	-	2.00±0.10
24	11.50±0.10	-	2.00±0.10
32	14.20±0.10	28.40±0.10	2.00±0.10
44	20.20±0.15	40.40±0.10	2.00±0.15
56	26.20±0.15	52.40±0.10	2.00±0.15
72	34.20±0.30	68.40±0.10	2.00±0.20

THIS DRAWING CONTAINS INFORMATION THAT IS PROPRIETARY TO MOLEX ELECTRONIC TECHNOLOGIES, LLC AND SHOULD NOT BE USED WITHOUT WRITTEN PERMISSION											
QUALITY SYMBOLS	RE-MASTERED IN ELECTR	EC NO: 119993	DRWN: MUM	CHKD: GMENARLY	REV APPR: KHLIM	GENERAL TOLERANCES (UNLESS SPECIFIED)		DIMENSION UNITS	SCALE		
						MM	INCH	MM	NTS		
▽A = 0	2017/06/27	2017/08/10	2017/08/10	4 PLACES ± ±	ATSEE	DATE	2015/08/24	PACKAGING SPECIFICATION FOR 87832 IN T&R		A	
▽E = 0	3 PLACES ± ±	CHK'D BY	DATE	2015/08/24	PACKAGING DESIGN DRAWING						
▽B = 0	2 PLACES ± ±	CGOH	DATE	2015/08/24	SERIES		MATERIAL NUMBER	CUSTOMER	GENERAL MARKET		
▽D = 0	1 PLACES ± ±	APPR BY	DATE	2017/05/26	87832		SEE TABLE				
▽C = 0	0 PLACES ± ±	KHLIM	DATE	2017/05/26	DOCUMENT NUMBER		DOC TYPE	DOC PART	SHEET NUMBER		
▽ = 0	ANGULAR TOL = 1.0	DRAWING SIZE		THIRD ANGLE PROJECTION	PK-87832-300		PDD	001	2 OF 12		
⊠ = 0	DRAFT WHERE APPLICABLE MUST REMAIN WITHIN DIMENSIONS	A3									
■ = 0											
▽ = 0											

CKTS	PART NUMBER	EMBOSSSED TAPE	REEL	TOP TAPE	OPTION (SEE SHEET 12)	EMBOSS WIDTH	QTY./REEL	REELS/CARTON	BUBBLE SHEETS QTY.			CORNER GUIDES 78888-1251	
									TOP	CENTER	BOTTOM		
4	87832-0406	89990-0145	89990-5709	89990-5602	1	16	500	7	-	-	-	-	
	87832-0407	89990-0145	89990-5709	89990-5602	1	16	500	7	-	-	-	-	
	87832-5122	89990-7601	89990-5709	89990-5602	1	16	500	7	-	-	-	-	
	87832-5123	89990-7601	89990-5709	89990-5602	1	16	500	7	-	-	-	-	
	87832-5162	89990-7601	89990-5709	89990-5602	1	16	500	7	-	-	-	-	
	87832-5172	89990-7601	89990-5709	89990-5602	1	16	500	7	-	-	-	-	
	87832-5106	151000-4241	89990-5710	89990-5603	2	24	500	5	-	-	-	-	
6	87832-0606	89990-7752	89990-5710	89990-5603	1	24	500	5	-	-	-	-	
	87832-0607	89990-7752	89990-5710	89990-5603	1	24	500	5	-	-	-	-	
	87832-0614	89990-7602	89990-5710	89990-5603	1	24	500	5	-	-	-	-	
	87832-0615	89990-7602	89990-5710	89990-5603	1	24	500	5	-	-	-	-	
	87832-0628	89990-7752	89990-5710	89990-5603	1	24	500	5	-	-	-	-	
	87832-0629	89990-7752	89990-5710	89990-5603	1	24	500	5	-	-	-	-	
	87832-0642	89990-7752	89990-5710	89990-5603	1	24	500	4	-	-	-	-	
	87832-5222	89990-7602	89990-5710	89990-5603	1	24	500	5	-	-	-	-	
	87832-5223	89990-7602	89990-5710	89990-5603	1	24	500	5	-	-	-	-	
	87832-5262	89990-7602	89990-5710	89990-5603	1	24	500	5	-	-	-	-	
	87832-5272	89990-7602	89990-5710	89990-5603	1	24	500	5	-	-	-	-	

<b>QUALITY SYMBOLS</b> 	THIS DRAWING CONTAINS INFORMATION THAT IS PROPRIETARY TO MOLEX ELECTRONIC TECHNOLOGIES, LLC AND SHOULD NOT BE USED WITHOUT WRITTEN PERMISSION											
	<b>RE-MASTERED IN ELECTR</b> EC NO: 119993 DRWN: MUM CHK'D: GMENARLY REV APPR: KHLIM	GENERAL TOLERANCES (UNLESS SPECIFIED)		DIMENSION UNITS		SCALE		 <b>PACKAGING SPECIFICATION FOR 87832 IN T&amp;R</b> <b>PACKAGING DESIGN DRAWING</b>				
		MM	INCH	MM	NTS							
		DRWN BY		DATE								
		ATSEE		2015/08/24								
		CHK'D BY		DATE								
	CGOH		2015/08/24									
	APPR BY		DATE									
	KHLIM		2017/05/26									
	DRAWING SIZE		THIRD ANGLE PROJECTION									
A3												
ANGULAR TOL = 1.0		DRAFT WHERE APPLICABLE MUST REMAIN WITHIN DIMENSIONS										
SERIES		MATERIAL NUMBER		CUSTOMER								
87832		SEE TABLE		GENERAL MARKET								
DOCUMENT NUMBER		DOC TYPE		DOC PART		SHEET NUMBER						
PK-87832-300		PDD		001		3 OF 12						

CKTS	PART NUMBER	EMBOSSSED TAPE	REEL	TOP TAPE	OPTION (SEE SHEET 12)	EMBOSS WIDTH	QTY./REEL	REELS/CARTON	BUBBLE SHEETS QTY.			CORNER GUIDES 78888-1251
									TOP	CENTER	BOTTOM	
8	87832-0806	89990-7753	89990-5710	89990-5603	1	24	500	5	-	-	-	-
	87832-0807	89990-7753	89990-5710	89990-5603	1	24	500	5	-	-	-	-
	87832-0814	89990-7603	89990-5710	89990-5603	1	24	500	5	-	-	-	-
	87832-0828	89990-7753	89990-5710	89990-5603	1	24	500	5	-	-	-	-
	87832-0829	89990-7753	89990-5710	89990-5603	1	24	500	5	-	-	-	-
	87832-0836	89990-7753	89990-5710	89990-5603	1	24	500	5	-	-	-	-
	87832-0842	89990-7753	89990-5710	89990-5603	1	24	500	5	-	-	-	-
	87832-5322	89990-7603	89990-5710	89990-5603	1	24	500	5	-	-	-	-
	87832-5323	89990-7603	89990-5710	89990-5603	1	24	500	5	-	-	-	-
	87832-5352	89990-7603	89990-5710	89990-5603	1	24	500	5	-	-	-	-
	87832-5362	89990-7603	89990-5710	89990-5603	1	24	500	5	-	-	-	-
	87832-5372	89990-7603	89990-5710	89990-5603	1	24	500	5	-	-	-	-

THIS DRAWING CONTAINS INFORMATION THAT IS PROPRIETARY TO MOLEX ELECTRONIC TECHNOLOGIES, LLC AND SHOULD NOT BE USED WITHOUT WRITTEN PERMISSION																														
<b>QUALITY SYMBOLS</b> 	<b>RE-MASTERED IN ECNTR</b> EC NO: 119993 DRWN: MUM CHK'D: GMENARLY REV APPR: KHLIM		2017/06/27 2017/08/10 2017/08/10		<b>GENERAL TOLERANCES (UNLESS SPECIFIED)</b> <table border="1"> <tr><th></th><th>MM</th><th>INCH</th></tr> <tr><td>4 PLACES</td><td>±</td><td>±</td></tr> <tr><td>3 PLACES</td><td>±</td><td>±</td></tr> <tr><td>2 PLACES</td><td>±</td><td>±</td></tr> <tr><td>1 PLACES</td><td>±</td><td>±</td></tr> <tr><td>0 PLACES</td><td>±</td><td>±</td></tr> </table>			MM	INCH	4 PLACES	±	±	3 PLACES	±	±	2 PLACES	±	±	1 PLACES	±	±	0 PLACES	±	±	<b>DIMENSION UNITS</b> MM INCH DRWN BY: ATSEE CHK'D BY: CGOH APPR BY: KHLIM		<b>SCALE</b> NTS DATE: 2015/08/24 DATE: 2015/08/24 DATE: 2017/05/26			
		MM	INCH																											
	4 PLACES	±	±																											
	3 PLACES	±	±																											
	2 PLACES	±	±																											
	1 PLACES	±	±																											
	0 PLACES	±	±																											
	<b>PACKAGING SPECIFICATION FOR 87832 IN T&amp;R</b>										<b>PACKAGING DESIGN DRAWING</b>																			
	SERIES: 87832		MATERIAL NUMBER: SEE TABLE				CUSTOMER: GENERAL MARKET																							
	DOCUMENT NUMBER: PK-87832-300						DOC TYPE: PDD	DOC PART: 001	SHEET NUMBER: 4 OF 12																					

CKTS	PART NUMBER	EMBOSSSED TAPE	REEL	TOP TAPE	OPTION (SEE SHEET 12)	EMBOSS WIDTH	QTY./REEL	REELS/CARTON	BUBBLE SHEETS QTY.			CORNER GUIDES 78888-1251
									TOP	CENTER	BOTTOM	
10	87832-1006	89990-7754	89990-5710	89990-5603	1	24	500	5	-	-	-	-
	87832-1007	89990-7754	89990-5710	89990-5603	1	24	500	5	-	-	-	-
	87832-1014	89990-7604	89990-5710	89990-5603	1	24	500	5	-	-	-	-
	87832-1028	89990-7754	89990-5710	89990-5603	1	24	500	5	-	-	-	-
	87832-1029	89990-7754	89990-5710	89990-5603	1	24	500	5	-	-	-	-
	87832-1040	89990-7754	89990-5710	89990-5603	1	24	500	5	-	-	-	-
	87832-1042	89990-7754	89990-5710	89990-5603	1	24	500	5	-	-	-	-
	87832-5422	89990-7604	89990-5710	89990-5603	1	24	500	5	-	-	-	-
	87832-5423	89990-7604	89990-5710	89990-5603	1	24	500	5	-	-	-	-
	87832-5462	89990-7604	89990-5710	89990-5603	1	24	500	5	-	-	-	-
	87832-5472	89990-7604	89990-5710	89990-5603	1	24	500	5	-	-	-	-
	87832-9423	89990-7704	89990-5710	89990-5603	2	24	400	5	-	-	-	-

THIS DRAWING CONTAINS INFORMATION THAT IS PROPRIETARY TO MOLEX ELECTRONIC TECHNOLOGIES, LLC AND SHOULD NOT BE USED WITHOUT WRITTEN PERMISSION																	
<b>QUALITY SYMBOLS</b> 	<b>RE-MASTERED IN ECTR</b> EC NO: 119993 DRWN: MUM CHK'D: GMENARLY REV APPR: KHLIM	<b>GENERAL TOLERANCES (UNLESS SPECIFIED)</b> MM    INCH		<b>DIMENSION UNITS</b> MM    NTS													
		4 PLACES ± ±		DRWN BY    DATE								<b>PACKAGING SPECIFICATION FOR 87832 IN T&amp;R</b>					
		3 PLACES ± ±		ATSEE    2015/08/24													
		2 PLACES ± ±		CHK'D BY    DATE		<b>PACKAGING DESIGN DRAWING</b>											
		1 PLACES ± ±		CGOH    2015/08/24													
		0 PLACES ± ±		APPR BY    DATE								SERIES: 87832    MATERIAL NUMBER: SEE TABLE    CUSTOMER: GENERAL MARKET					
		ANGULAR TOL = 1.0		KHLIM    2017/05/26		DOCUMENT NUMBER: PK-87832-300    DOC TYPE: PDD    DOC PART: 001    SHEET NUMBER: 5 OF 12											
		DRAFT WHERE APPLICABLE MUST REMAIN WITHIN DIMENSIONS		DRAWING SIZE: A3    THIRD ANGLE PROJECTION													

CKTS	PART NUMBER	EMBOSSSED TAPE	REEL	TOP TAPE	OPTION (SEE SHEET 12)	EMBOSS WIDTH	QTY./REEL	REELS/CARTON	BUBBLE SHEETS QTY.			CORNER GUIDES 78888-1251
									TOP	CENTER	BOTTOM	
12	87832-1206	89990-7755	89990-5711	89990-5604	1	32	500	4	-	-	-	-
	87832-1207	89990-7755	89990-5711	89990-5604	1	32	500	4	-	-	-	-
	87832-1242	89990-7755	89990-5711	89990-5604	1	32	500	4	-	-	-	-
	87832-1228	89990-7755	89990-5711	89990-5604	1	32	500	4	-	-	-	-
	87832-1229	89990-7755	89990-5711	89990-5604	1	32	500	4	-	-	-	-
	87832-5522	89990-7605	89990-5711	89990-5604	1	32	500	4	-	-	-	-
	87832-5523	89990-7605	89990-5711	89990-5604	1	32	500	4	-	-	-	-
	87832-5562	89990-7605	89990-5711	89990-5604	1	32	500	4	-	-	-	-
	87832-5572	89990-7605	89990-5711	89990-5604	1	32	500	4	-	-	-	-
14	87832-1414	89990-7756	89990-5711	89990-5604	1	32	500	4	-	-	-	-
	87832-5622	89990-7756	89990-5711	89990-5604	1	32	500	4	-	-	-	-
	87832-5623	89990-7756	89990-5711	89990-5604	1	32	500	4	-	-	-	-
	87832-5662	89990-7756	89990-5711	89990-5604	1	32	500	4	-	-	-	-
	87832-5672	89990-7756	89990-5711	89990-5604	1	32	500	4	-	-	-	-
	87832-9523	89990-7706	89990-5711	89990-5604	2	32	500	4	-	-	-	-

THIS DRAWING CONTAINS INFORMATION THAT IS PROPRIETARY TO MOLEX ELECTRONIC TECHNOLOGIES, LLC AND SHOULD NOT BE USED WITHOUT WRITTEN PERMISSION																	
<b>QUALITY SYMBOLS</b> 	<b>RE-MASTERED IN ELECTR</b> EC NO: 119993 DRWN: MUM CHK'D: GMENARLY REV APPR: KHLIM	<b>GENERAL TOLERANCES (UNLESS SPECIFIED)</b> MM    INCH		<b>DIMENSION UNITS</b> MM    NTS													
		4 PLACES ±    ±		DRWN BY    DATE ATSEE    2015/08/24								<b>PACKAGING SPECIFICATION FOR 87832 IN T&amp;R</b>					
		3 PLACES ±    ±		CHK'D BY    DATE CGOH    2015/08/24													
		2 PLACES ±    ±		APPR BY    DATE KHLIM    2017/05/26		SERIES    MATERIAL NUMBER    CUSTOMER 87832    SEE TABLE    GENERAL MARKET											
		1 PLACES ±    ±		DRAFT WHERE APPLICABLE MUST REMAIN WITHIN DIMENSIONS		DRAWING SIZE    THIRD ANGLE PROJECTION A3		DOCUMENT NUMBER    DOC TYPE    DOC PART    SHEET NUMBER PK-87832-300    PDD    001    6 OF 12									
		0 PLACES ±    ±		ANGULAR TOL = 1.0		SCALE											

CKTS	PART NUMBER	EMBOSSSED TAPE	REEL	TOP TAPE	OPTION (SEE SHEET 12)	EMBOSS WIDTH	QTY./REEL	REELS/CARTON	BUBBLE SHEETS QTY.			CORNER GUIDES 78888-1251
									TOP	CENTER	BOTTOM	
16	87832-1614	89990-7757	89990-5711	89990-5604	1	32	500	4	-	-	-	-
	87832-5722	89990-7757	89990-5711	89990-5604	1	32	500	4	-	-	-	-
	87832-5723	89990-7757	89990-5711	89990-5604	1	32	500	4	-	-	-	-
	87832-5762	89990-7757	89990-5711	89990-5604	1	32	500	4	-	-	-	-
	87832-5772	89990-7757	89990-5711	89990-5604	1	32	500	4	-	-	-	-
18	87832-1814	89990-7658	89990-5712	89990-5605	3	44	500	3	-	-	-	-
	87832-1815	89990-7658	89990-5712	89990-5605	3	44	500	3	-	-	-	-
	87832-5822	89990-7758	89990-5712	89990-5605	1	44	500	3	-	-	-	-
	87832-5823	89990-7758	89990-5712	89990-5605	1	44	500	3	-	-	-	-
	87832-5862	89990-7758	89990-5712	89990-5605	1	44	500	3	-	-	-	-
	87832-5872	89990-7758	89990-5712	89990-5605	1	44	500	3	-	-	-	-
20	87832-2014	89990-7759	89990-5712	89990-5605	1	44	500	3	-	-	-	-
	87832-5922	89990-7759	89990-5712	89990-5605	1	44	500	3	-	-	-	-
	87832-5923	89990-7759	89990-5712	89990-5605	1	44	500	3	-	-	-	-
	87832-5962	89990-7759	89990-5712	89990-5605	1	44	500	3	-	-	-	-
	87832-5972	89990-7759	89990-5712	89990-5605	1	44	500	3	-	-	-	-

THIS DRAWING CONTAINS INFORMATION THAT IS PROPRIETARY TO MOLEX ELECTRONIC TECHNOLOGIES, LLC AND SHOULD NOT BE USED WITHOUT WRITTEN PERMISSION																														
<b>QUALITY SYMBOLS</b> 	<b>RE-MASTERED IN ELECTR</b> EC NO: 119993 DRWN: MUM CHK'D: GMENARLY REV APPR: KHLIM		2017/06/27 2017/08/10 2017/08/10		<b>GENERAL TOLERANCES (UNLESS SPECIFIED)</b> <table border="1"> <tr> <td></td> <td>MM</td> <td>INCH</td> </tr> <tr> <td>4 PLACES</td> <td>±</td> <td>±</td> </tr> <tr> <td>3 PLACES</td> <td>±</td> <td>±</td> </tr> <tr> <td>2 PLACES</td> <td>±</td> <td>±</td> </tr> <tr> <td>1 PLACES</td> <td>±</td> <td>±</td> </tr> <tr> <td>0 PLACES</td> <td>±</td> <td>±</td> </tr> </table>			MM	INCH	4 PLACES	±	±	3 PLACES	±	±	2 PLACES	±	±	1 PLACES	±	±	0 PLACES	±	±	<b>DIMENSION UNITS</b> MM		<b>SCALE</b> NTS			
		MM	INCH																											
	4 PLACES	±	±																											
	3 PLACES	±	±																											
	2 PLACES	±	±																											
	1 PLACES	±	±																											
	0 PLACES	±	±																											
	<b>DRWN BY</b> ATSEE		<b>DATE</b> 2015/08/24		<b>PACKAGING SPECIFICATION FOR 87832 IN T&amp;R</b>																									
	<b>CHK'D BY</b> CGOH		<b>DATE</b> 2015/08/24						<b>PACKAGING DESIGN DRAWING</b>																					
	<b>APPR BY</b> KHLIM		<b>DATE</b> 2017/05/26		<b>SERIES</b> 87832		<b>MATERIAL NUMBER</b> SEE TABLE						<b>CUSTOMER</b> GENERAL MARKET																	
<b>ANGULAR TOL = 1.0</b>		<b>DRAFT WHERE APPLICABLE MUST REMAIN WITHIN DIMENSIONS</b>		<b>DRAWING SIZE</b> A3		<b>THIRD ANGLE PROJECTION</b>		<b>DOCUMENT NUMBER</b> PK-87832-300		<b>DOC TYPE</b> PDD		<b>DOC PART</b> 001		<b>SHEET NUMBER</b> 7 OF 12																

CKTS	PART NUMBER	EMBOSSSED TAPE	REEL	TOP TAPE	OPTION (SEE SHEET 12)	EMBOSS WIDTH	QTY./REEL	REELS/CARTON	BUBBLE SHEETS QTY.			CORNER GUIDES 78888-1251
									TOP	CENTER	BOTTOM	
22	87832-6022	89990-7760	89990-5712	89990-5605	1	44	500	3	-	-	-	-
	87832-6023	89990-7760	89990-5712	89990-5605	1	44	500	3	-	-	-	-
	87832-6052	89990-7760	89990-5712	89990-5605	1	44	500	3	-	-	-	-
	87832-6062	89990-7760	89990-5712	89990-5605	1	44	500	3	-	-	-	-
	87832-6072	89990-7760	89990-5712	89990-5605	1	44	500	3	-	-	-	-
24	87832-2414	89990-7761	89990-5712	89990-5605	1	44	500	3	-	-	-	-
	87832-6122	89990-7761	89990-5712	89990-5605	1	44	500	3	-	-	-	-
	87832-6123	89990-7761	89990-5712	89990-5605	1	44	500	3	-	-	-	-
	87832-6162	89990-7761	89990-5712	89990-5605	1	44	500	3	-	-	-	-
	87832-6172	89990-7761	89990-5712	89990-5605	1	44	500	3	-	-	-	-
26	87832-6222	89990-7762	89990-5712	89990-5605	1	44	500	3	-	-	-	-
	87832-6223	89990-7762	89990-5712	89990-5605	1	44	500	3	-	-	-	-
	87832-6262	89990-7762	89990-5712	89990-5605	1	44	500	3	-	-	-	-
	87832-6272	89990-7762	89990-5712	89990-5605	1	44	500	3	-	-	-	-

THIS DRAWING CONTAINS INFORMATION THAT IS PROPRIETARY TO MOLEX ELECTRONIC TECHNOLOGIES, LLC AND SHOULD NOT BE USED WITHOUT WRITTEN PERMISSION													
<b>QUALITY SYMBOLS</b> 	RE-MASTERED IN ELECTRICAL			EC NO: 119993 DRWN: MUM CHK'D: GMENARLY REV APPR: KHLIM		2017/06/27 2017/08/10 2017/08/10		GENERAL TOLERANCES (UNLESS SPECIFIED) MM INCH 4 PLACES ± ± 3 PLACES ± ± 2 PLACES ± ± 1 PLACES ± ± 0 PLACES ± ±		DIMENSION UNITS MM NTS DRWN BY ATSEE DATE 2015/08/24 CHK'D BY CGOH DATE 2015/08/24 APPR BY KHLIM DATE 2017/05/26			
	DIMENSION UNITS: MM NTS SCALE: NTS DRAWING SIZE: A3 THIRD ANGLE PROJECTION:								PACKAGING SPECIFICATION FOR 87832 IN T&R				
	ANGULAR TOL = 1.0 DRAFT WHERE APPLICABLE MUST REMAIN WITHIN DIMENSIONS								PACKAGING DESIGN DRAWING				
	SERIES		MATERIAL NUMBER		CUSTOMER		87832		SEE TABLE		GENERAL MARKET		
	DOCUMENT NUMBER				DOC TYPE		DOC PART		SHEET NUMBER		8 OF 12		
	PK-87832-300				PDD		001						

CKTS	PART NUMBER	EMBOSSSED TAPE	REEL	TOP TAPE	OPTION (SEE SHEET 12)	EMBOSS WIDTH	QTY./REEL	REELS/CARTON	BUBBLE SHEETS QTY.			CORNER GUIDES 78888-1251
									TOP	CENTER	BOTTOM	
28	87832-6322	89990-7763	89990-5713	89990-5606	1	56	500	2	-	-	-	-
	87832-6323	89990-7763	89990-5713	89990-5606	1	56	500	2	-	-	-	-
	87832-6362	89990-7763	89990-5713	89990-5606	1	56	500	2	-	-	-	-
	87832-6372	89990-7763	89990-5713	89990-5606	1	56	500	2	-	-	-	-
30	87832-3014	89990-7664	89990-5712	89990-5605	3	56	500	2	-	-	-	-
	87832-6422	89990-7764	89990-5713	89990-5605	1	56	500	2	-	-	-	-
	87832-6423	89990-7764	89990-5713	89990-5605	1	56	500	2	-	-	-	-
	87832-6462	89990-7764	89990-5713	89990-5605	1	56	500	2	-	-	-	-
	87832-6472	89990-7764	89990-5713	89990-5605	1	56	500	2	-	-	-	-
32	87832-6522	89990-7765	89990-5713	89990-5606	1	56	500	2	-	-	-	-
	87832-6523	89990-7765	89990-5713	89990-5606	1	56	500	2	2	2	2	Y
	87832-6562	89990-7765	89990-5713	89990-5606	1	56	500	2	-	-	-	-
	87832-6572	89990-7765	89990-5713	89990-5606	1	56	500	2	-	-	-	-

THIS DRAWING CONTAINS INFORMATION THAT IS PROPRIETARY TO MOLEX ELECTRONIC TECHNOLOGIES, LLC AND SHOULD NOT BE USED WITHOUT WRITTEN PERMISSION												
<b>QUALITY SYMBOLS</b> 	<b>RE-MASTERED IN ELECTR</b> EC NO: 119993 DRWN: MUM CHK'D: GMENARLY REV APPR: KHLIM	GENERAL TOLERANCES (UNLESS SPECIFIED)		DIMENSION UNITS		SCALE		 <b>PACKAGING SPECIFICATION FOR 87832 IN T&amp;R</b>				
		MM	INCH	MM	NTS	DRWN BY	DATE					
		4 PLACES ±	±	ATSEE	2015/08/24	CHK'D BY	DATE	<b>PACKAGING DESIGN DRAWING</b>				
		3 PLACES ±	±	CGOH	2015/08/24	APPR BY	DATE					
		2 PLACES ±	±	KHLIM	2017/05/26	DRAWING SIZE	THIRD ANGLE PROJECTION	SERIES	MATERIAL NUMBER	CUSTOMER		
		1 PLACES ±	±	A3		87832	SEE TABLE	GENERAL MARKET				
		0 PLACES ±	±	ANGULAR TOL = 1.0		DOCUMENT NUMBER		DOC TYPE	DOC PART	SHEET NUMBER		
		DRAFT WHERE APPLICABLE MUST REMAIN WITHIN DIMENSIONS				PK-87832-300		PDD	001	9 OF 12		

CKTS	PART NUMBER	EMBOSSSED TAPE	REEL	TOP TAPE	OPTION (SEE SHEET 12)	EMBOSS WIDTH	QTY./REEL	REELS/CARTON	BUBBLE SHEETS QTY.			CORNER GUIDES 78888-1251
									TOP	CENTER	BOTTOM	
34	87832-3414	89990-7666	89990-5713	89990-5606	3	56	500	2	-	-	-	-
	87832-6622	89990-7766	89990-5713	89990-5606	1	56	500	2	-	-	-	-
	87832-6623	89990-7766	89990-5713	89990-5606	1	56	500	2	-	-	-	-
	87832-6662	89990-7766	89990-5713	89990-5606	1	56	500	2	-	-	-	-
	87832-6672	89990-7766	89990-5713	89990-5606	1	56	500	2	-	-	-	-
40	87832-6922	89990-7769	89990-5713	89990-5605	1	56	500	2	-	-	-	-
	87832-6923	89990-7769	89990-5713	89990-5605	1	56	500	2	-	-	-	-
	87832-6962	89990-7769	89990-5713	89990-5605	1	56	500	2	-	-	-	-
	87832-6972	89990-7769	89990-5713	89990-5605	1	56	500	2	-	-	-	-
42	87832-7023	151000-4140	89990-5772	89990-5607	1	72	150	2	1	-	1	Y

THIS DRAWING CONTAINS INFORMATION THAT IS PROPRIETARY TO MOLEX ELECTRONIC TECHNOLOGIES, LLC AND SHOULD NOT BE USED WITHOUT WRITTEN PERMISSION											
<b>QUALITY SYMBOLS</b> 	<b>RE-MASTERED IN ECTR</b> EC NO: 119993 DRWN: MUM CHK'D: GMENARLY REV APPR: KHLIM	GENERAL TOLERANCES (UNLESS SPECIFIED)		DIMENSION UNITS		SCALE		 <b>PACKAGING SPECIFICATION FOR 87832 IN T&amp;R</b>			
		MM	INCH	MM	NTS						
		4 PLACES ±	±	DRWN BY	DATE	<b>PACKAGING DESIGN DRAWING</b>					
		3 PLACES ±	±	ATSEE	2015/08/24						
		2 PLACES ±	±	CHK'D BY	DATE						
		1 PLACES ±	±	CGOH	2015/08/24	SERIES: 87832    MATERIAL NUMBER: SEE TABLE    CUSTOMER: GENERAL MARKET					
		0 PLACES ±	±	APPR BY	DATE						
		ANGULAR TOL = 1.0		KHLIM	2017/05/26	DOCUMENT NUMBER: PK-87832-300    DOC TYPE: PDD    DOC PART: 001    SHEET NUMBER: 10 OF 12					
		DRAFT WHERE APPLICABLE MUST REMAIN WITHIN DIMENSIONS		DRAWING SIZE: A3	THIRD ANGLE PROJECTION						

CKTS	PART NUMBER	EMBOSSSED TAPE	REEL	TOP TAPE	OPTION (SEE SHEET 12)	EMBOSS WIDTH	QTY./REEL	REELS/CARTON	BUBBLE SHEETS QTY.			CORNER GUIDES 78888-1251
									TOP	CENTER	BOTTOM	
44	87832-4415	89990-7671	89990-5713	89990-5606	3	56	500	2	-	-	-	-
	87832-7122	89990-7771	89990-5713	89990-5606	1	56	500	2	-	-	-	-
	87832-7123	89990-7771	89990-5713	89990-5606	1	56	500	2	-	-	-	-
	87832-7162	89990-7771	89990-5713	89990-5606	1	56	500	2	-	-	-	-
	87832-7172	89990-7771	89990-5713	89990-5606	1	56	500	2	-	-	-	-
46	87832-7222	89990-7772	89990-5772	89990-5607	1	56	500	2	-	-	-	-
	87832-7262	89990-7772	89990-5772	89990-5607	1	56	500	2	-	-	-	-
	87832-7272	89990-7772	89990-5772	89990-5607	1	56	500	2	-	-	-	-
50	87832-7422	89990-7774	89990-5772	89990-5607	1	56	500	2	-	-	-	-
	87832-7423	89990-7774	89990-5772	89990-5607	1	56	500	2	-	-	-	-
	87832-7462	89990-7774	89990-5772	89990-5607	1	56	500	2	-	-	-	-
	87832-7472	89990-7774	89990-5772	89990-5607	1	56	500	2	-	-	-	-

THIS DRAWING CONTAINS INFORMATION THAT IS PROPRIETARY TO MOLEX ELECTRONIC TECHNOLOGIES, LLC AND SHOULD NOT BE USED WITHOUT WRITTEN PERMISSION														
<b>QUALITY SYMBOLS</b> 	RE-MASTERED IN ELECTRICAL		2017/06/27		2017/08/10		2017/08/10		GENERAL TOLERANCES (UNLESS SPECIFIED)		DIMENSION UNITS		SCALE	
	EC NO: 119993		DRWN: MUM		CHK'D: GMENARLY		REV APPR: KHLIM		MM INCH		MM NTS		MOLEX®	
	4 PLACES ±		±		DRWN BY		DATE		ATSEE		2015/08/24		PACKAGING SPECIFICATION FOR 87832 IN T&R	
	3 PLACES ±		±		CHK'D BY		DATE		CGOH		2015/08/24			
	2 PLACES ±		±		APPR BY		DATE		KHLIM		2017/05/26		PACKAGING DESIGN DRAWING	
	1 PLACES ±		±		DRAWING SIZE		THIRD ANGLE PROJECTION		A3				SERIES MATERIAL NUMBER CUSTOMER	
	0 PLACES ±		±		ANGULAR TOL = 1.0		DRAFT WHERE APPLICABLE MUST REMAIN WITHIN DIMENSIONS		87832		SEE TABLE		GENERAL MARKET	
	□ = 0		A		DOCUMENT NUMBER		DOC TYPE DOC PART SHEET NUMBER		PK-87832-300		PDD 001		11 OF 12	

# PACKAGING OPTIONS

OPTION 1

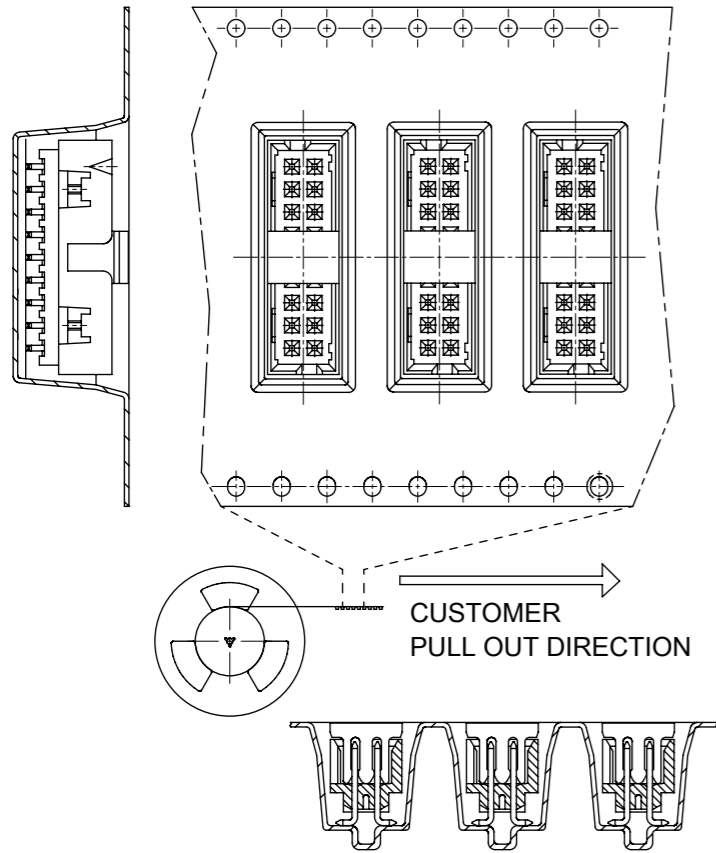

OPTION 2

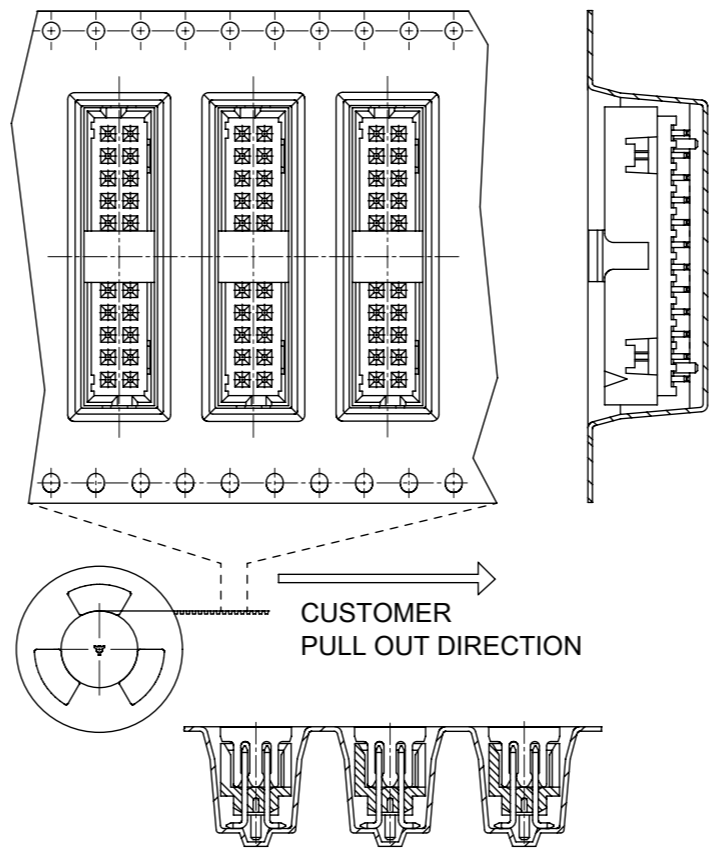

OPTION 3

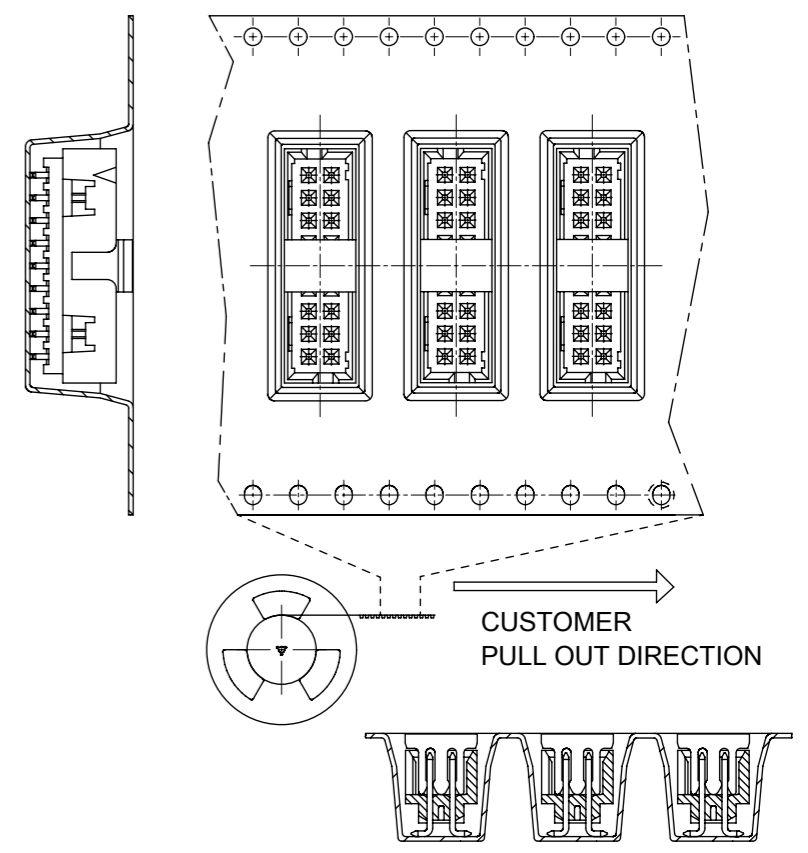

## EMBOSSED TAPE & REEL POCKET DESCRIPTIONS

OPTIONS	CENTER POLARIZATION OPTIONS		PEG OPTIONS		PILOT HOLE OPTIONS	
	ON THE LEFT	ON THE RIGH	WITH PEG	WITHOUT PEG	2 SIDES	1 SIDE
1	YES	N.A	YES	N.A	CKT 12 - 50	CKT 4 - 10
2	N.A	YES	YES	YES	CKT 12 - 50	CKT 4 - 10
3	YES	N.A	N.A	YES	CKT 12 - 50	CKT 4 - 10

<b>QUALITY SYMBOLS</b> ▽A = 0 ▽C = 0 ▽B = 0 ▼ = 0 ▽C = 0 ⊠ = 0 ■ = 0 ▽ = 0	THIS DRAWING CONTAINS INFORMATION THAT IS PROPRIETARY TO MOLEX ELECTRONIC TECHNOLOGIES, LLC AND SHOULD NOT BE USED WITHOUT WRITTEN PERMISSION										
	RE-MASTERED IN ELECTR EC NO: 119993 DRWN: MUM CHK'D: GMENARLY REV APPR: KHLIM	2017/06/27	2017/08/10	2017/08/10	GENERAL TOLERANCES (UNLESS SPECIFIED)		DIMENSION UNITS		SCALE		
					MM	INCH	MM	NTS			
		4 PLACES	±	±	DRWN BY	DATE	ATSEE		2015/08/24		
		3 PLACES	±	±	CHK'D BY	DATE	CGOH		2015/08/24		
		2 PLACES	±	±	APPR BY	DATE	KHLIM		2017/05/26		
	1 PLACES	±	±	ANGULAR TOL = 1.0		DRAWING SIZE	THIRD ANGLE PROJECTION				
	0 PLACES	±	±	DRAFT WHERE APPLICABLE MUST REMAIN WITHIN DIMENSIONS		A3					
								SERIES		MATERIAL NUMBER	
								87832		SEE TABLE	
							CUSTOMER		GENERAL MARKET		
							DOCUMENT NUMBER		DOC TYPE		
							PK-87832-300		PDD		
							DOC PART		SHEET NUMBER		
							001		12 OF 12		

## Looking for pricing, stock, or lifecycle information?

Click below to explore more details on WIN SOURCE:

[View 0878325923 on WIN SOURCE](#)

[Molex, LLC Information](#)

## Optimize Your Supply Chain with WIN SOURCE Solutions

- ✓ Global Sourcing Solution
- ✓ Obsolete Management
- ✓ Cost Control Management
- ✓ Shortage Management
- ✓ Alternative Solution
- ✓ Excess Inventory Management