

General Description

The ICS854110I is a high-performance differential LVDS clock fanout buffer. The device is designed for signal fanout of high-frequency, low phase-noise clock signals. The selected differential input signal is distributed to ten differential LVDS outputs. The ICS854110I is characterized to operate from a 2.5V power supply. Guaranteed output-to-output and part-to-part skew characteristics make the ICS854110I ideal for those clock distribution applications demanding well-defined performance and repeatability. The device offers an output slew rate control with four pre-set output transition times to solve crosstalk and EMI problems in complex board designs. A fail-safe input design forces the outputs to a defined state if differential clock inputs are open or shorted, see Table 3D.

Features

- Two differential input reference clocks
- Differential pair can accept the following differential input levels: LVPECL, LVDS
- Ten LVDS outputs
- Maximum clock frequency: 200MHz
- Output slew rate control
- Fail-safe differential inputs
- LVCMOS interface levels for all control inputs
- Output skew: 260ps (maximum), for fastest slew rate setting of 0.650 V/ns
- Part-to-part skew: 1.2ns (maximum)
- Full 2.5V supply voltage
- Lead-free (RoHS 6) 32-Lead VFQFN and 32-Lead LQFP package
- -40°C to 85°C ambient operating temperature

Block Diagram

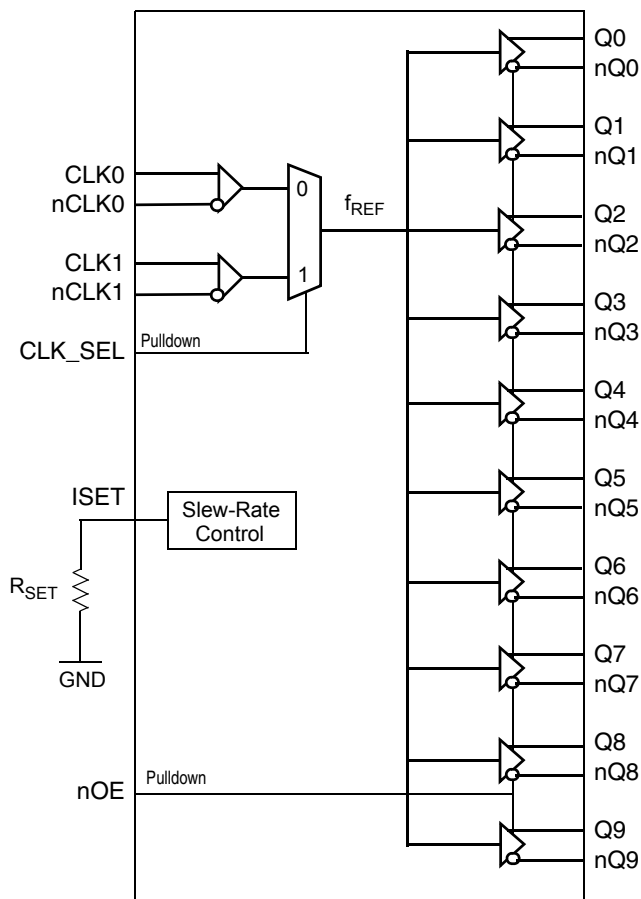

Pin Assignments

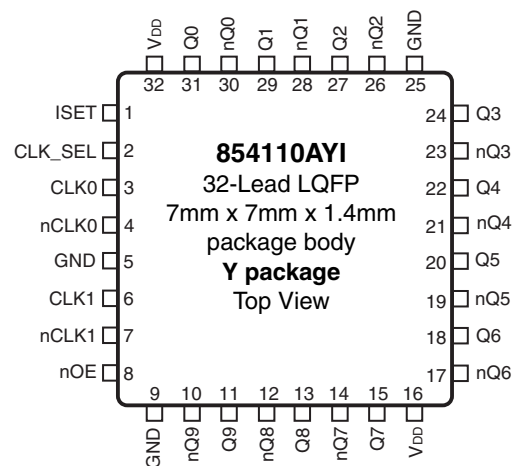
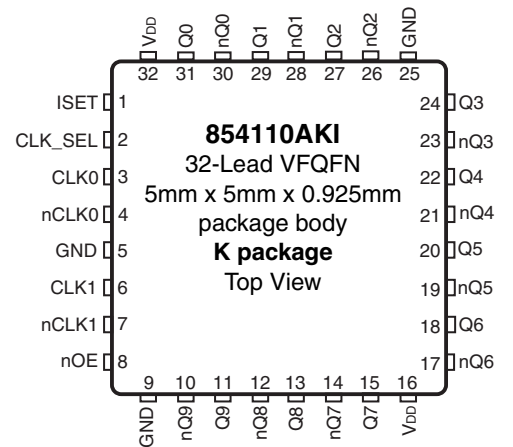

Table 1. Pin Descriptions

| Number | Name | Type | | Description |
|----------|-----------------|--------|----------|--|
| 1 | ISET | | | An external fixed resistor (RSET) from this pin to ground is needed to provide a reference current for setting the slew rate of the differential outputs Q[0:9], nQ[0:9]. See Table 3C for function. |
| 2 | CLK_SEL | Input | Pulldown | Input clock select. See Table 3A for function. LVCMOS/LVTTL interface levels. |
| 3 | CLK0 | Input | | Non-inverting clock/data input 0. |
| 4 | nCLK0 | Input | | Inverting differential clock input 0. |
| 5, 9, 25 | GND | Power | | Power supply ground. |
| 6 | CLK1 | Input | | Non-inverting clock/data input 1. |
| 7 | nCLK1 | Input | | Inverting differential clock input 1. |
| 8 | nOE | Input | Pulldown | Output enable. See Table 3B for function. LVCMOS/LVTTL interface levels. |
| 10, 11 | nQ9, Q9 | Output | | Differential output pair 9. LVDS interface levels. |
| 12, 13 | nQ8, Q8 | Output | | Differential output pair 8. LVDS interface levels. |
| 14, 15 | nQ7, Q7 | Output | | Differential output pair 7. LVDS interface levels. |
| 16, 32 | V _{DD} | Power | | Power supply pins. |
| 17, 18 | nQ6, Q6 | Output | | Differential output pair 6. LVDS interface levels. |
| 19, 20 | nQ5, Q5 | Output | | Differential output pair 5. LVDS interface levels. |
| 21, 22 | nQ4, Q4 | Output | | Differential output pair 4. LVDS interface levels. |
| 23, 24 | nQ3, Q3 | Output | | Differential output pair 3. LVDS interface levels. |
| 26, 27 | nQ2, Q2 | Output | | Differential output pair 2. LVDS interface levels. |
| 28, 29 | nQ1, Q1 | Output | | Differential output pair 1. LVDS interface levels. |
| 30, 31 | nQ0, Q0 | Output | | Differential output pair 0. LVDS interface levels. |

NOTE: *Pulldown* refers to an internal input resistor. See Table 2, *Pin Characteristics*, for typical values.

Table 2. Pin Characteristics

| Symbol | Parameter | Test Conditions | Minimum | Typical | Maximum | Units |
|-----------------------|-------------------------|-----------------|---------|---------|---------|-------|
| C _{IN} | Input Capacitance | | | 4 | | pF |
| R _{PULLDOWN} | Input Pulldown Resistor | | | 51 | | kΩ |

Function Tables

Table 3A. CLK_SEL Configuration Table

| Input | Operation |
|---------|---|
| CLK_SEL | |
| 0 | CLK0, nCLK0 is the selected reference clock |
| 1 | CLK1, nCLK1 is the selected reference clock |

NOTE: CLK_SEL is an asynchronous control.

Table 3B. nOE Configuration Table

| Input | Operation |
|-------|--|
| nOE | |
| 0 | Outputs Qx, nQx are enabled. |
| 1 | Outputs Qx, nQx are in high-impedance state. |

NOTE: OE is an asynchronous control.

Table 3C. R_{SET} Configuration Table

| R _{SET} | Typical Output Slew Rate (V/ns) |
|--------------------|---------------------------------|
| Resistor Size (kΩ) | |
| 4 | 0.650 (fastest) |
| 15 | 0.170 |
| 50 | 0.150 |
| 150 | 0.115 (slowest) |

NOTE: The RSET resistor at the ISET pin allows configuration of the outputs to one of four pre-set output slew rates. A 5% variation of the RSET resistor size will be tolerated.

NOTE: Slew rates are defined as $\pm 100\text{mV}$ from the center of Q – nQ signal.

Table 3D. Guaranteed Input Fail Safe Operations for CLK0, nCLK0 and CLK1, nCLK1

| Input State of Selected Input | Outputs Q[0:9], nQ[0:9] |
|---|-----------------------------------|
| Logic Low (Selected Input: CLKx = LOW, nCLKx = HIGH) | Logic Low (Qx = LOW, nQx = HIGH) |
| Logic High (Selected Input: CLKx = HIGH, nCLKx = LOW) | Logic High (Qx = HIGH, nQx = LOW) |
| Inputs Open (Selected Input: CLKx = open, nCLKx = open) | Logic High (Qx = HIGH, nQx = LOW) |
| Inputs Shorted (Selected Input: CLKx shorted to nCLKx and tied to V _{DD}) | Logic High (Qx = HIGH, nQx = LOW) |
| Input Shorted (Selected Input: CLKx shorted to nCLKx and floating) | Logic High (Qx = HIGH, nQx = LOW) |

Absolute Maximum Ratings

NOTE: Stresses beyond those listed under *Absolute Maximum Ratings* may cause permanent damage to the device. These ratings are stress specifications only. Functional operation of product at these conditions or any conditions beyond those listed in the *DC Characteristics* or *AC Characteristics* is not implied. Exposure to absolute maximum rating conditions for extended periods may affect product reliability.

| Item | Rating |
|---|--------------------------------------|
| Supply Voltage, V_{DD} | 4.6V |
| Inputs, V_I | -0.5V to $V_{DD} + 0.5V$ |
| Outputs, I_O (LVDS) Continuous Current Surge Current | 10mA 15mA |
| Package Thermal Impedance, θ_{JA} 32 Lead VFQFN 32 Lead LQFP | 37.0°C/W (0 mps) 65.7°C/W (0 mps) |
| Storage Temperature, T_{STG} | -65°C to 150°C |

DC Electrical Characteristics

Table 4A. Power Supply DC Characteristics, $V_{DD} = 2.5V \pm 5\%$, $T_A = -40^\circ C$ to $85^\circ C$

| Symbol | Parameter | Test Conditions | Minimum | Typical | Maximum | Units |
|----------|----------------------|--|---------|---------|---------|-------|
| V_{DD} | Power Supply Voltage | | 2.375 | 2.5 | 2.625 | V |
| I_{DD} | Power Supply Current | No Load, R_{SET} not connected | | | 18 | mA |
| | | All Outputs Loaded, $R_{SET} = 4k\Omega$ | | | 86 | mA |
| | | No Load, $R_{SET} = 4k\Omega$ | | | 30 | mA |

Table 4B. LVCMOS/LVTTL Input DC Characteristics, $V_{DD} = 2.5V \pm 5\%$, $T_A = -40^\circ C$ to $85^\circ C$

| Symbol | Parameter | Test Conditions | Minimum | Typical | Maximum | Units |
|----------|--------------------|--|---------|---------|----------------|---------|
| V_{IH} | Input High Voltage | | 2 | | $V_{DD} + 0.3$ | V |
| V_{IL} | Input Low Voltage | | -0.3 | | 0.8 | V |
| I_{IH} | Input High Current | CLK_SEL, nOE $V_{DD} = V_{IN} = 2.625V$ | | | 150 | μA |
| I_{IL} | Input Low Current | CLK_SEL, nOE $V_{DD} = 2.625V, V_{IN} = 0V$ | -5 | | | μA |

Table 4C. Differential DC Characteristics, $V_{DD} = 2.5V \pm 5\%$, $T_A = -40^\circ C$ to $85^\circ C$

| Symbol | Parameter | Test Conditions | Minimum | Typical | Maximum | Units |
|-----------|---|-----------------|-----------|---------|-----------------|-------|
| V_{PP} | Peak-to-Peak Input Voltage; NOTE 1 | | 0.15 | | 1.2 | V |
| V_{CMR} | Common Mode Input Voltage; NOTE 1, 2 | | GND + 0.8 | | $V_{DD} - 0.85$ | V |

NOTE 1: V_{IL} should not be less than -0.3V.

NOTE 2: Common mode input voltage is defined as V_{IH} .

Table 4D. LVDS DC Characteristics, $V_{DD} = 2.5V \pm 5\%$, $T_A = -40^{\circ}C$ to $85^{\circ}C$

| Symbol | Parameter | Test Conditions | Minimum | Typical | Maximum | Units |
|-----------------|-----------------------------|----------------------|---------|---------|---------|-------|
| V_{OD} | Differential Output Voltage | $R_{SET} = 4k\Omega$ | 250 | | 600 | mV |
| ΔV_{OD} | V_{OD} Magnitude Change | $R_{SET} = 4k\Omega$ | | | 50 | mV |
| V_{OS} | Offset Voltage | $R_{SET} = 4k\Omega$ | 1.115 | | 1.430 | V |
| ΔV_{OS} | V_{OS} Magnitude Change | $R_{SET} = 4k\Omega$ | | | 50 | mV |

AC Electrical Characteristics

Table 5. AC Electrical Characteristics, $V_{DD} = 2.5V \pm 5\%$, $T_A = -40^{\circ}C$ to $85^{\circ}C$

| Symbol | Parameter | Test Conditions | Minimum | Typical | Maximum | Units | |
|--------------|---|---|------------------------|---------|---------|-------|-----|
| f_{REF} | Input Frequency | $R_{SET} = 4k\Omega$ | | | 200 | MHz | |
| | | $R_{SET} = 15k\Omega$ | | | 30 | MHz | |
| | | $R_{SET} = 50k\Omega$ | | | 20 | MHz | |
| | | $R_{SET} = 150k\Omega$ | | | 16 | MHz | |
| f_{OUT} | Output Frequency | Q[9:0], nQ[9:0] | $R_{SET} = 4k\Omega$ | | | 200 | MHz |
| | | | $R_{SET} = 15k\Omega$ | | | 30 | MHz |
| | | | $R_{SET} = 50k\Omega$ | | | 20 | MHz |
| | | | $R_{SET} = 150k\Omega$ | | | 16 | MHz |
| t_{JIT} | Buffer Additive Phase Jitter, RMS; refer to Additive Phase Jitter Section | $R_{SET} = 4k\Omega$, $f_{REF} = 125MHz$, Integration Range: 12kHz – 20MHz | | 0.291 | | ps | |
| t_{PD} | Propagation Delay; NOTE 1 | CLKx, nCLKx to any Qx, nQx output | $R_{SET} = 4k\Omega$ | 3.2 | 4.0 | 4.6 | ns |
| | | | $R_{SET} = 15k\Omega$ | 4.6 | 5.5 | 6.3 | ns |
| | | | $R_{SET} = 50k\Omega$ | 5.4 | 6.5 | 7.7 | ns |
| | | | $R_{SET} = 150k\Omega$ | 7.5 | 8.3 | 9.3 | ns |
| $t_{sk(o)}$ | Output Skew; NOTE 2, 3 | $R_{SET} = 4k\Omega$ | | 125 | 260 | ps | |
| | | $R_{SET} = 15k\Omega$ | | 160 | 425 | ps | |
| | | $R_{SET} = 50k\Omega$ | | 200 | 525 | ps | |
| | | $R_{SET} = 150k\Omega$ | | 240 | 550 | ps | |
| $t_{sk(p)}$ | Pulse Skew | $R_{SET} = 4k\Omega$ | | 80 | 185 | ps | |
| | | $R_{SET} \neq 4k\Omega$ | | | 265 | ps | |
| $t_{sk(pp)}$ | Part-to-Part Skew; NOTE 3, 4 | $R_{SET} = 4k\Omega$ | | 600 | 1200 | ps | |
| | | $R_{SET} = 15k\Omega$ | | 825 | 1500 | ps | |
| | | $R_{SET} = 50k\Omega$ | | 975 | 2100 | ps | |
| | | $R_{SET} = 150k\Omega$ | | 1245 | 1650 | ps | |
| $t_{sl(o)}$ | Output Clock Slew Rate | $R_{SET} = 4k\Omega$ | 0.450 | 0.650 | 1.3 | V/ns | |
| | | $R_{SET} = 15k\Omega$ | 0.110 | 0.170 | 0.350 | V/ns | |
| | | $R_{SET} = 50k\Omega$ | 0.110 | 0.150 | 0.325 | V/ns | |
| | | $R_{SET} = 150k\Omega$ | 0.075 | 0.115 | 0.250 | V/ns | |
| odc | Output Duty Cycle; NOTE 5 | $R_{SET} = 4k\Omega$, $f_{REF} \leq 200MHz$ | 45 | 50 | 55 | % | |
| | | $R_{SET} = 15k\Omega$, $f_{REF} \leq 30MHz$ | 48 | 50 | 52 | % | |
| | | $R_{SET} = 50k\Omega$, $f_{REF} \leq 20MHz$ | 48 | 50 | 52 | % | |
| | | $R_{SET} = 150k\Omega$, $f_{REF} \leq 16MHz$ | 48 | 50 | 52 | % | |

| Symbol | Parameter | Test Conditions | Minimum | Typical | Maximum | Units |
|-------------|---------------------------------------|------------------------|---------|---------|---------|-------|
| t_R / t_F | Output Rise/ Fall Time; 30% to 70% | $R_{SET} = 4k\Omega$ | 100 | 300 | 500 | ps |
| | | $R_{SET} = 15k\Omega$ | 600 | 1030 | 1600 | ps |
| | | $R_{SET} = 50k\Omega$ | 650 | 1160 | 1850 | ps |
| | | $R_{SET} = 150k\Omega$ | 800 | 1540 | 2200 | ps |

NOTE: Electrical parameters are guaranteed over the specified ambient operating temperature range, which is established when the device is mounted in a test socket with maintained transverse airflow greater than 500 lfpm. The device will meet specifications after thermal equilibrium has been reached under these conditions.

NOTE 1: Measured from the differential input crossing point to the differential output crossing point.

NOTE 2: Defined as skew between outputs at the same supply voltage and with equal load conditions. Measured at the differential cross points.

NOTE 3: This parameter is defined in accordance with JEDEC Standard 65.

NOTE 4: Defined as skew between outputs on different devices operating at the same supply voltage, same frequency, same temperature and with equal load conditions. Using the same type of inputs on each device, the outputs are measured at the differential cross points.

NOTE 5: Input Duty Cycle must be 50%.

Additive Phase Jitter

The spectral purity in a band at a specific offset from the fundamental compared to the power of the fundamental is called the **dBc Phase Noise**. This value is normally expressed using a Phase noise plot and is most often the specified plot in many applications. Phase noise is defined as the ratio of the noise power present in a 1Hz band at a specified offset from the fundamental frequency to the power value of the fundamental. This ratio is expressed in decibels (dBm) or a

ratio of the power in the 1Hz band to the power in the fundamental. When the required offset is specified, the phase noise is called a **dBc** value, which simply means dBm at a specified offset from the fundamental. By investigating jitter in the frequency domain, we get a better understanding of its effects on the desired application over the entire time record of the signal. It is mathematically possible to calculate an expected bit error rate given a phase noise plot.

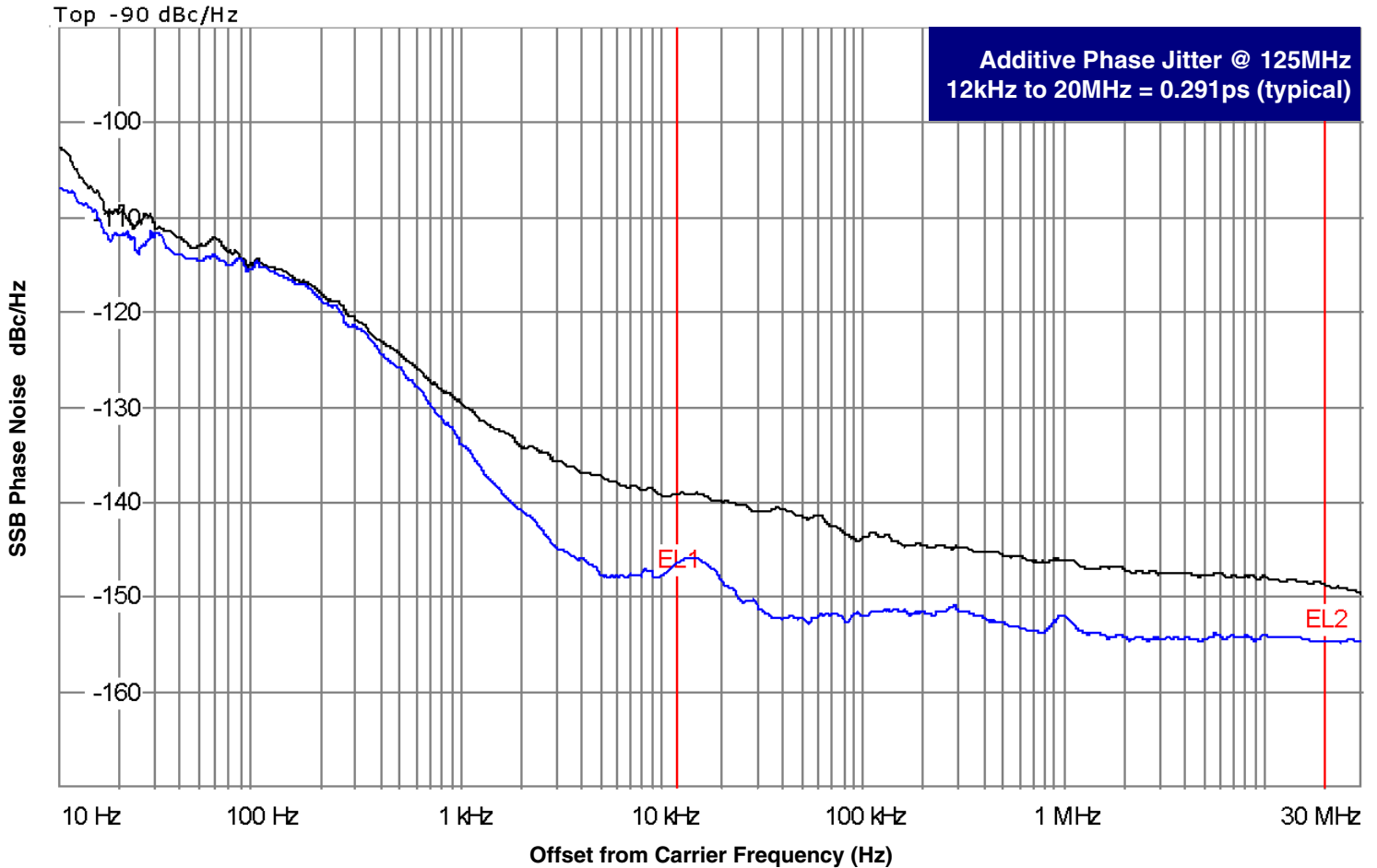

As with most timing specifications, phase noise measurements have issues relating to the limitations of the equipment. Often the noise floor of the equipment is higher than the noise floor of the device. This is illustrated above. The device meets the noise floor of what is shown, but can actually be lower. The phase noise is dependent on the input source and measurement equipment.

The source generator used is, "Rohde & Schwarz SMA 100A Signal Generator into a HP 8133A 3GHz Pulse Generator".

Parameter Measurement Information

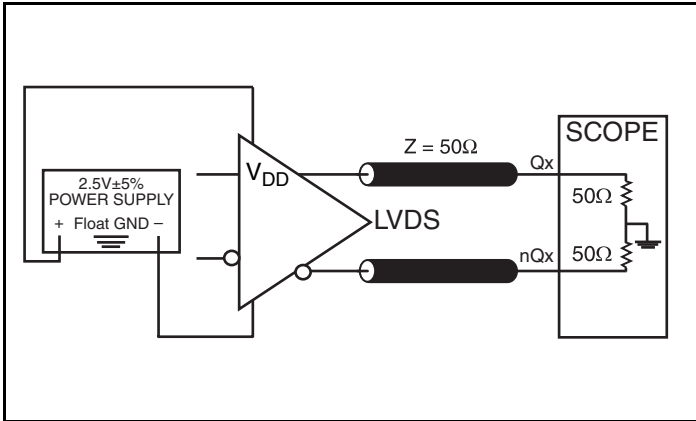

2.5V LVDS Output Load AC Test Circuit

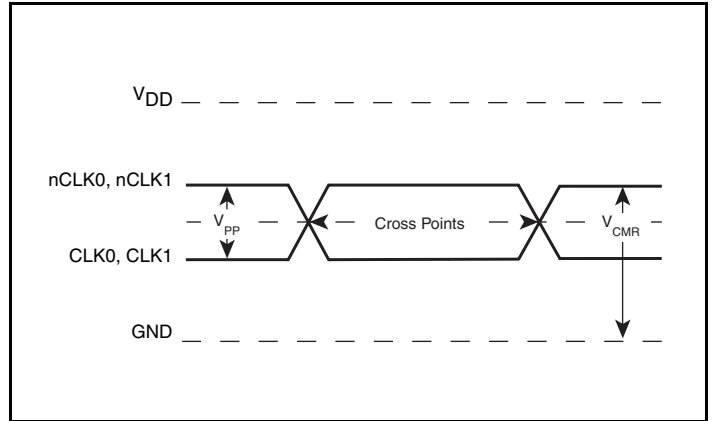

Differential Input Level

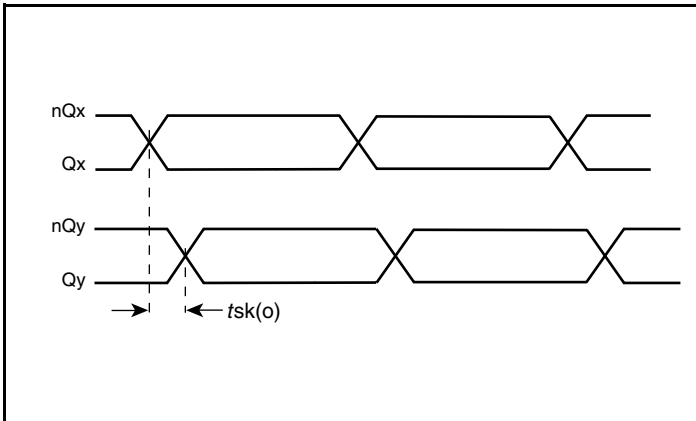

Output Skew

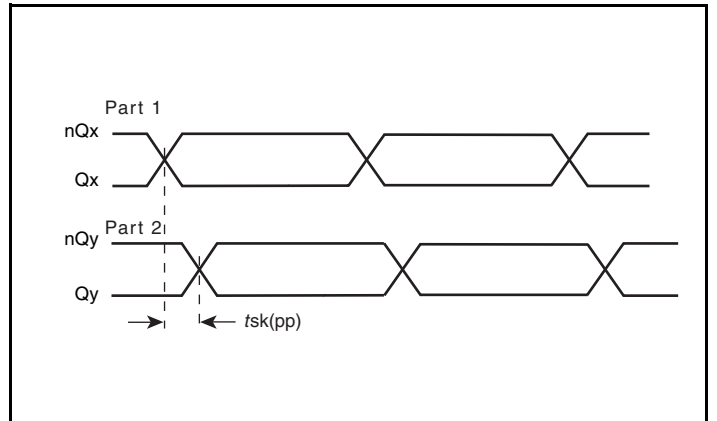

Part-to-Part Skew

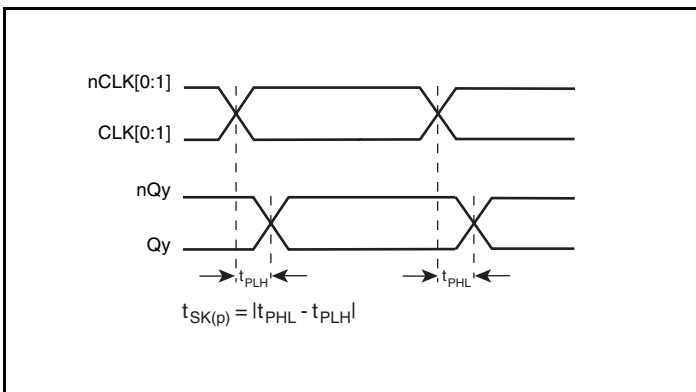

Pulse Skew

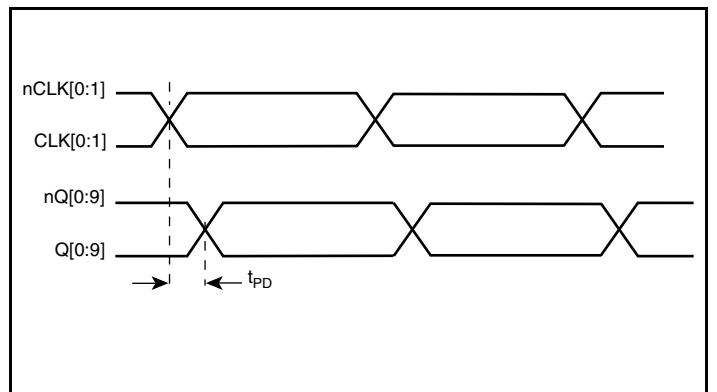

Propagation Delay

Parameter Measurement Information, continued

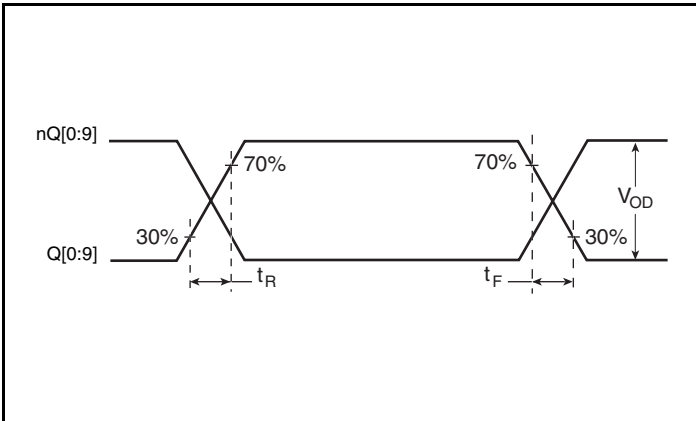

Output Rise/Fall Time

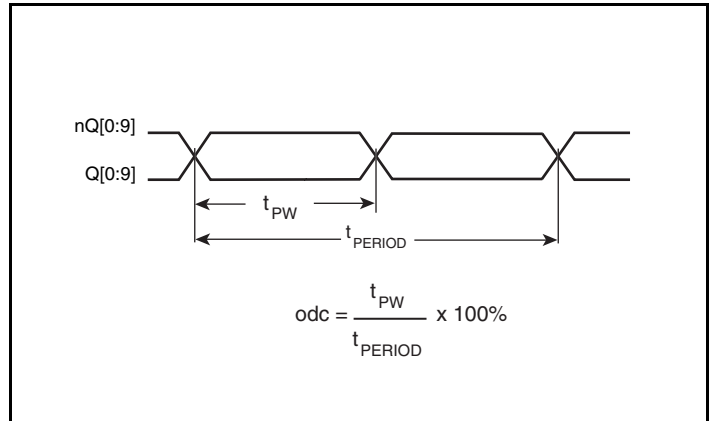

Output Duty Cycle/Pulse Width/Period

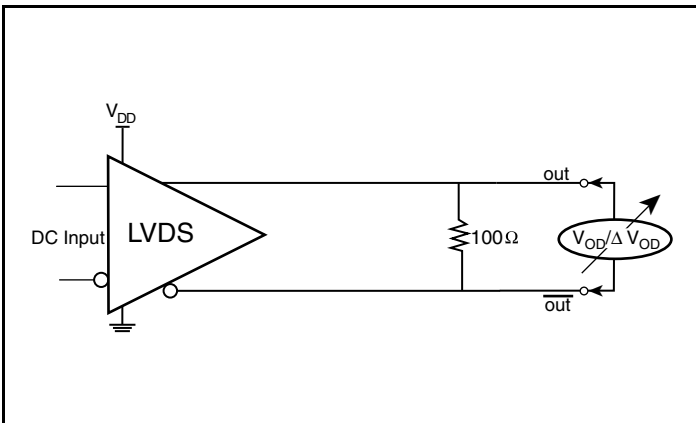

Differential Output Voltage Setup

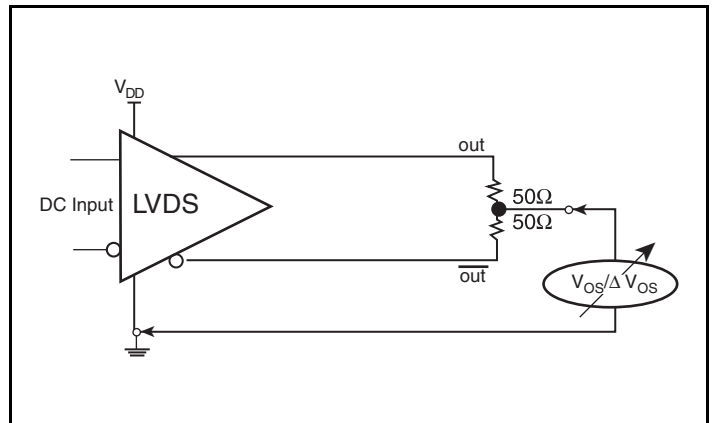

Offset Voltage Setup

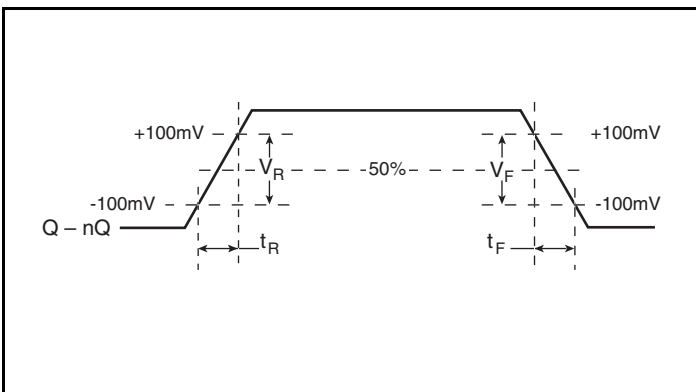

Differential Output Slew Rate

Applications Information

Wiring the Differential Input to Accept Single-Ended Levels

Figure 1 shows how a differential input can be wired to accept single ended levels. The reference voltage $V_{REF} = V_{DD}/2$ is generated by the bias resistors R1 and R2. The bypass capacitor (C1) is used to help filter noise on the DC bias. This bias circuit should be located as close to the input pin as possible. The ratio of R1 and R2 might need to be adjusted to position the V_{REF} in the center of the input voltage swing. For example, if the input clock swing is 2.5V and $V_{DD} = 3.3V$, R1 and R2 value should be adjusted to set V_{REF} at 1.25V. The values below are for when both the single ended swing and V_{DD} are at the same voltage. This configuration requires that the sum of the output impedance of the driver (R_o) and the series resistance (R_s) equals the transmission line impedance. In addition, matched termination at the input will attenuate the signal in half. This can be done in one of two ways. First, R3 and R4 in parallel should equal the transmission

line impedance. For most 50Ω applications, R3 and R4 can be 100Ω. The values of the resistors can be increased to reduce the loading for slower and weaker LVCMOS driver. When using single-ended signaling, the noise rejection benefits of differential signaling are reduced. Even though the differential input can handle full rail LVCMOS signaling, it is recommended that the amplitude be reduced. The datasheet specifies a lower differential amplitude, however this only applies to differential signals. For single-ended applications, the swing can be larger, however V_{IL} cannot be less than -0.3V and V_{IH} cannot be more than $V_{DD} + 0.3V$. Though some of the recommended components might not be used, the pads should be placed in the layout. They can be utilized for debugging purposes. The datasheet specifications are characterized and guaranteed by using a differential signal.

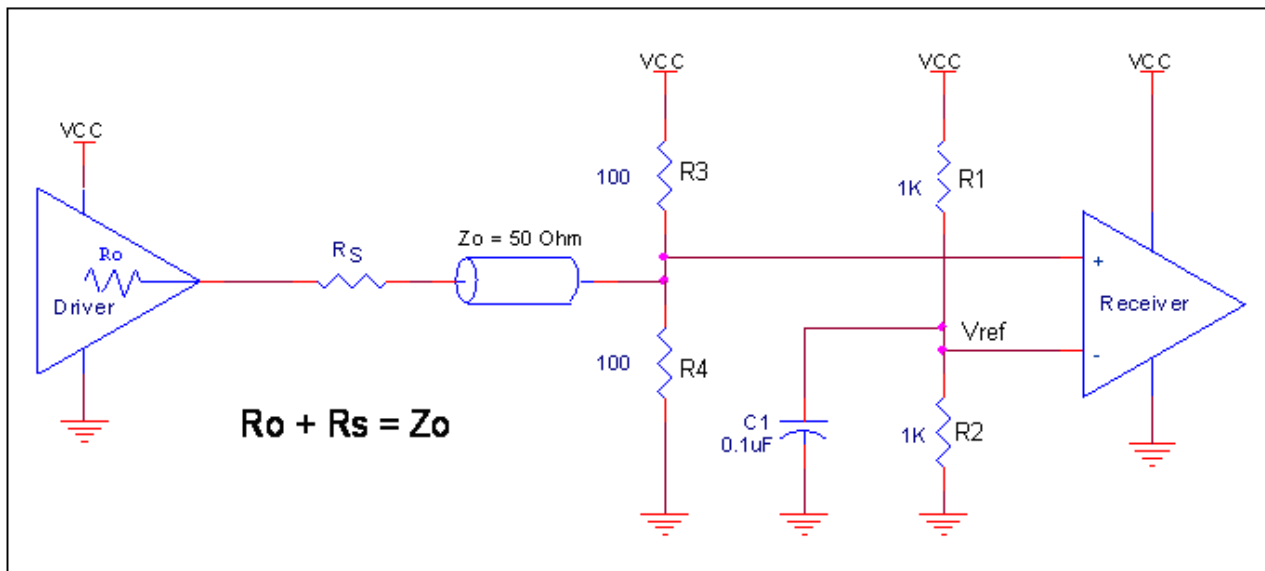

Figure 1. Recommended Schematic for Wiring a Differential Input to Accept Single-ended Levels

Recommendations for Unused Input and Output Pins

Inputs:

CLK/nCLK Inputs

For applications not requiring the use of the differential input, both CLK and nCLK can be left floating. Though not required, but for additional protection, a 1kΩ resistor can be tied from CLK to ground.

LVCMOS Control Pins

All control pins have internal pull-ups or pull-downs; additional resistance is not required but can be added for additional protection. A 1kΩ resistor can be used.

Outputs:

LVDS Outputs

All unused LVDS outputs should be terminated with 100Ω resistor between the differential pair.

Differential Clock Input Interface

The CLK/nCLK accepts LVPECL, LVDS and other differential signals. Both differential signals must meet the V_{PP} and V_{CMR} input requirements. *Figures 2A to 2C* show interface examples for the CLK/nCLK input driven by the most common driver types. The input

interfaces suggested here are examples only. If the driver is from another vendor, use their termination recommendation. Please consult with the vendor of the driver component to confirm the driver termination requirements.

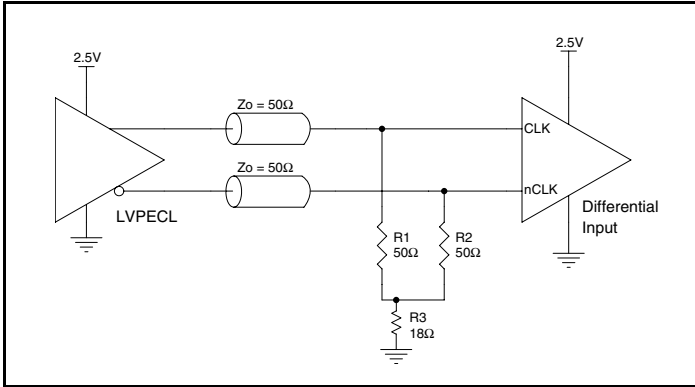

Figure 2A. CLK/nCLK Input Driven by a 2.5V LVPECL Driver

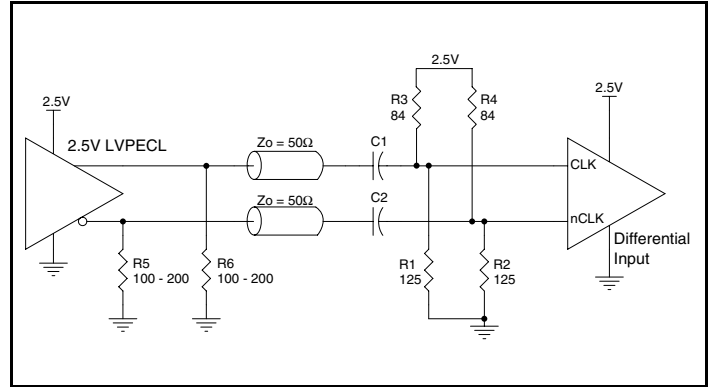

Figure 2B. CLK/nCLK Input Driven by a 2.5V LVPECL Driver with AC Coupler

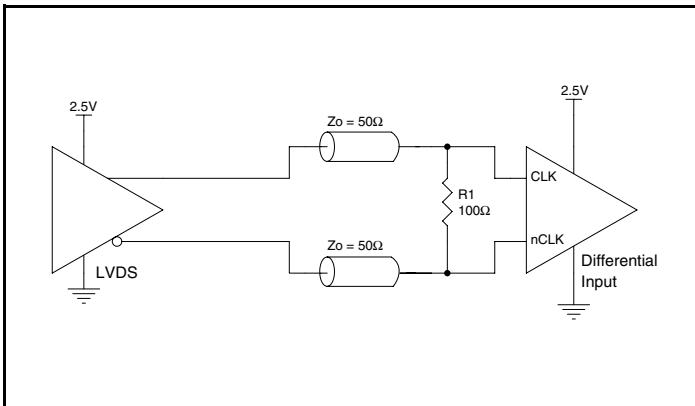

Figure 2C. CLK/nCLK Input Driven by an LVDS Driver

VFQFN EPAD Thermal Release Path

In order to maximize both the removal of heat from the package and the electrical performance, a land pattern must be incorporated on the Printed Circuit Board (PCB) within the footprint of the package corresponding to the exposed metal pad or exposed heat slug on the package, as shown in *Figure 3*. The solderable area on the PCB, as defined by the solder mask, should be at least the same size/shape as the exposed pad/slug area on the package to maximize the thermal/electrical performance. Sufficient clearance should be designed on the PCB between the outer edges of the land pattern and the inner edges of pad pattern for the leads to avoid any shorts.

While the land pattern on the PCB provides a means of heat transfer and electrical grounding from the package to the board through a solder joint, thermal vias are necessary to effectively conduct from the surface of the PCB to the ground plane(s). The land pattern must be connected to ground through these vias. The vias act as “heat pipes”. The number of vias (i.e. “heat pipes”) are application specific

and dependent upon the package power dissipation as well as electrical conductivity requirements. Thus, thermal and electrical analysis and/or testing are recommended to determine the minimum number needed. Maximum thermal and electrical performance is achieved when an array of vias is incorporated in the land pattern. It is recommended to use as many vias connected to ground as possible. It is also recommended that the via diameter should be 12 to 13mils (0.30 to 0.33mm) with 1 oz copper via barrel plating. This is desirable to avoid any solder wicking inside the via during the soldering process which may result in voids in solder between the exposed pad/slug and the thermal land. Precautions should be taken to eliminate any solder voids between the exposed heat slug and the land pattern. Note: These recommendations are to be used as a guideline only. For further information, please refer to the Application Note on the Surface Mount Assembly of Amkor’s Thermally/Electrically Enhance Leadframe Base Package, Amkor Technology.

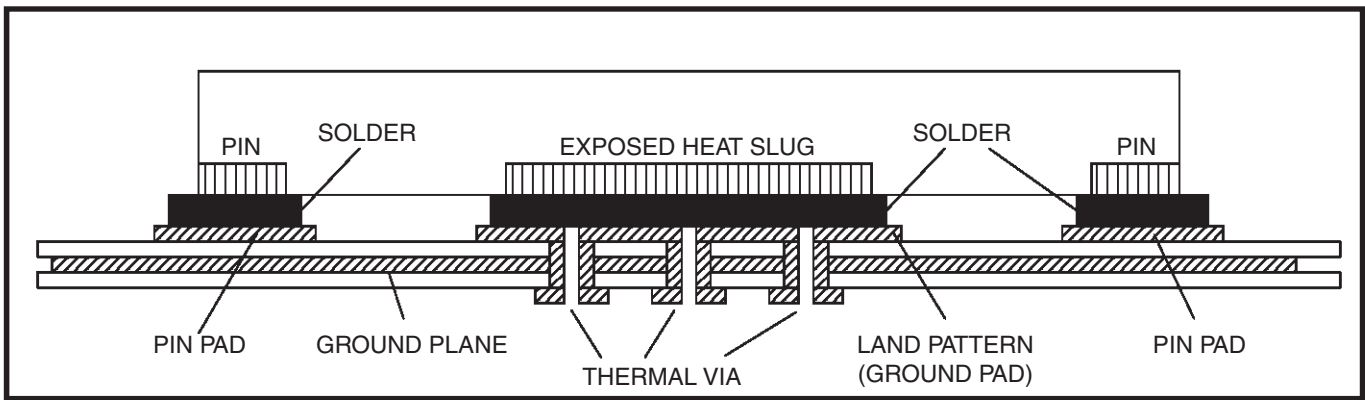

Figure 3. P.C. Assembly for Exposed Pad Thermal Release Path – Side View (drawing not to scale)

LVDS Driver Termination

A general LVDS interface is shown in *Figure 4*. Standard termination for LVDS type output structure requires both a 100Ω parallel resistor at the receiver and a 100Ω differential transmission line environment. In order to avoid any transmission line reflection issues, the 100Ω resistor must be placed as close to the receiver as possible. IDT offers a full line of LVDS compliant devices with two types of output structures: current source and voltage source. The standard

termination schematic as shown in *Figure 4* can be used with either type of output structure. If using a non-standard termination, it is recommended to contact IDT and confirm if the output is a current source or a voltage source type structure. In addition, since these outputs are LVDS compatible, the amplitude and common mode input range of the input receivers should be verified for compatibility with the output.

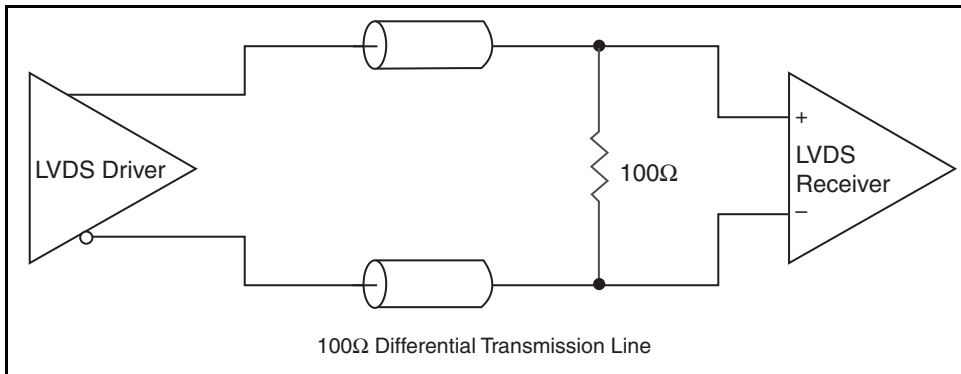

Figure 4. Typical LVDS Driver Termination

Power Considerations

This section provides information on power dissipation and junction temperature for the ICS854110I. Equations and example calculations are also provided.

1. Power Dissipation.

The total power dissipation for the ICS854110I is the sum of the core power plus the power dissipation in the load(s). The following is the power dissipation for $V_{DD} = 2.5V + 5\% = 2.625V$, which gives worst case results.

Total power dissipation, includes power dissipation on external components.

- $P_{\text{core+load}} = V_{DD_MAX} * I_{DD_core+load} = 2.625V * 86mA = \mathbf{225.75mW}$

Where:

$I_{DD_core+load}$ is the total supply current which includes external components

To calculate the power dissipation on the device alone, P_{d_total} , and use it for junction temperature calculation, subtract the power dissipation on the external components.

- $P_{d_total} = P_{\text{core+load}} - (P_{\text{load}} + P_{\text{rset}})$

Where:

P_{load} is power dissipation on the output loadings

P_{rset} is power dissipation on the R_{SET}

The load current per output is:

- $I_{out} = (I_{DD_core+load} - I_{DD_no_load}) / N = (86mA - 18mA) / 10 = \mathbf{6.8mA}$

Where:

$I_{DD_no_load}$ is I_{DD} current at no load condition

N is number of outputs

Power Dissipation on output loads

- $P_{\text{load}} = (I_{out})^2 * R_{load} * N = (6.8mA)^2 * 100\Omega * 10 = \mathbf{46.2mW}$

Power Dissipation on R_{SET}

- $P_{\text{rset}} = (V_{rset})^2 / R_{SET} = (1V)^2 / 4k\Omega = \mathbf{0.25mW}$

(NOTE: P_{rset} is small and can be negligible)

Total Power Dissipation on the part excluding the power dissipation on the external components.

$$\begin{aligned} P_{d_total} &= P_{\text{core+load}} - (P_{\text{load}} + P_{\text{rset}}) \\ &= 225.75mW - (46.2mW + 0.25mW) \\ &= \mathbf{179.3mW} \end{aligned}$$

2. Junction Temperature.

Junction temperature, T_j , is the temperature at the junction of the bond wire and bond pad, and directly affects the reliability of the device. The maximum recommended junction temperature is 125°C. Limiting the internal transistor junction temperature, T_j , to 125°C ensures that the bond wire and bond pad temperature remains below 125°C.

The equation for T_j is as follows: $T_j = \theta_{JA} * Pd_{total} + T_A$

T_j = Junction Temperature

θ_{JA} = Junction-to-Ambient Thermal Resistance

Pd_{total} = Total Device Power Dissipation (example calculation is in section 1 above)

T_A = Ambient Temperature

In order to calculate junction temperature, the appropriate junction-to-ambient thermal resistance θ_{JA} must be used. Assuming no air flow and a multi-layer board, the appropriate value is 65.7°C/W per Table 6A below.

Therefore, T_j for an ambient temperature of 85°C with all outputs switching is:

$$85^\circ\text{C} + 0.179\text{W} * 65.7^\circ\text{C/W} = 96.8^\circ\text{C}.$$

This is below the limit of 125°C.

This calculation is only an example. T_j will obviously vary depending on the number of loaded outputs, supply voltage, air flow and the type of board (multi-layer).

Table 6A. Thermal Resistance θ_{JA} for 32 Lead LQFP, Forced Convection

| θ_{JA} by Velocity | | | |
|---|----------|----------|----------|
| Meters per Second | 0 | 1 | 2.5 |
| Multi-Layer PCB, JEDEC Standard Test Boards | 65.7°C/W | 55.9°C/W | 52.4°C/W |

Table 6B. Thermal Resistance θ_{JA} for 32 Lead VFQFN, Forced Convection

| θ_{JA} by Velocity | | | |
|---|----------|----------|----------|
| Meters per Second | 0 | 1 | 2.5 |
| Multi-Layer PCB, JEDEC Standard Test Boards | 37.0°C/W | 32.4°C/W | 29.0°C/W |

Reliability Information

Table 7A. θ_{JA} vs. Air Flow Table for a 32-Lead VFQFN

| θ_{JA} vs. Air Flow | | | |
|---|----------|----------|----------|
| Meters per Second | 0 | 1 | 2.5 |
| Multi-Layer PCB, JEDEC Standard Test Boards | 37.0°C/W | 32.4°C/W | 29.0°C/W |

Table 7B. θ_{JA} vs. Air Flow Table for a 32-Lead LQFP

| θ_{JA} vs. Air Flow | | | |
|---|----------|----------|----------|
| Meters per Second | 0 | 1 | 2.5 |
| Multi-Layer PCB, JEDEC Standard Test Boards | 65.7°C/W | 55.9°C/W | 52.4°C/W |

Transistor Count

The transistor count for ICS854110I is: 1757

Package Outline and Package Dimensions

Package Outline - K Suffix for 32-Lead VFQFN

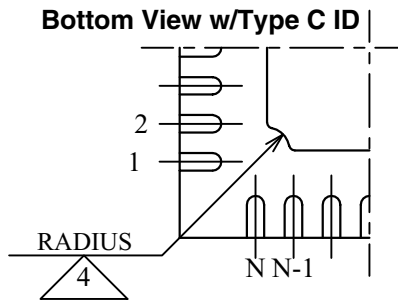
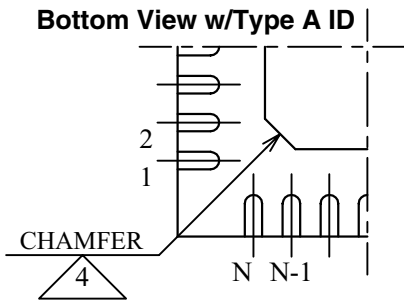
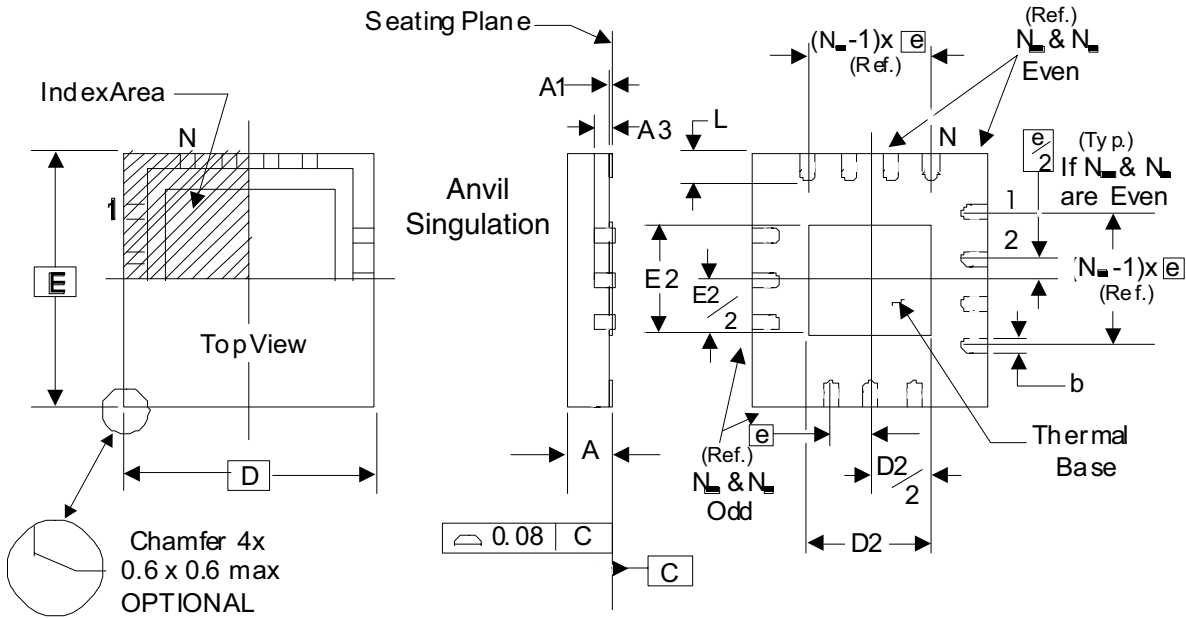

There are 2 methods of indicating pin 1 corner at the back of the VFQFN package are:

1. Type A: Chamfer on the paddle (near pin 1)
2. Type C: Mouse bite on the paddle (near pin 1)

Table 8A. Package Dimensions for 32-Lead VFQFN

| JEDEC Variation: VHHD-2/-4 | | |
|-------------------------------|------------|---------|
| All Dimensions in Millimeters | | |
| Symbol | Minimum | Maximum |
| N | 32 | |
| A | 0.80 | 1.00 |
| A1 | 0 | 0.05 |
| A3 | 0.25 Ref. | |
| b | 0.18 | 0.30 |
| N_D & N_E | 8 | |
| D & E | 5.00 Basic | |
| D2 & E2 | 3.0 | 3.3 |
| e | 0.50 Basic | |
| L | 0.30 | 0.50 |

NOTE: The following package mechanical drawing is a generic drawing that applies to any pin count VFQFN package. This drawing is not intended to convey the actual pin count or pin layout of this device. The pin count and pinout are shown on the front page. The package dimensions are in Table 8A.

Reference Document: JEDEC Publication 95, MO-220

Package Outline and Package Dimensions

Package Outline - Y Suffix for 32-Lead LQFP

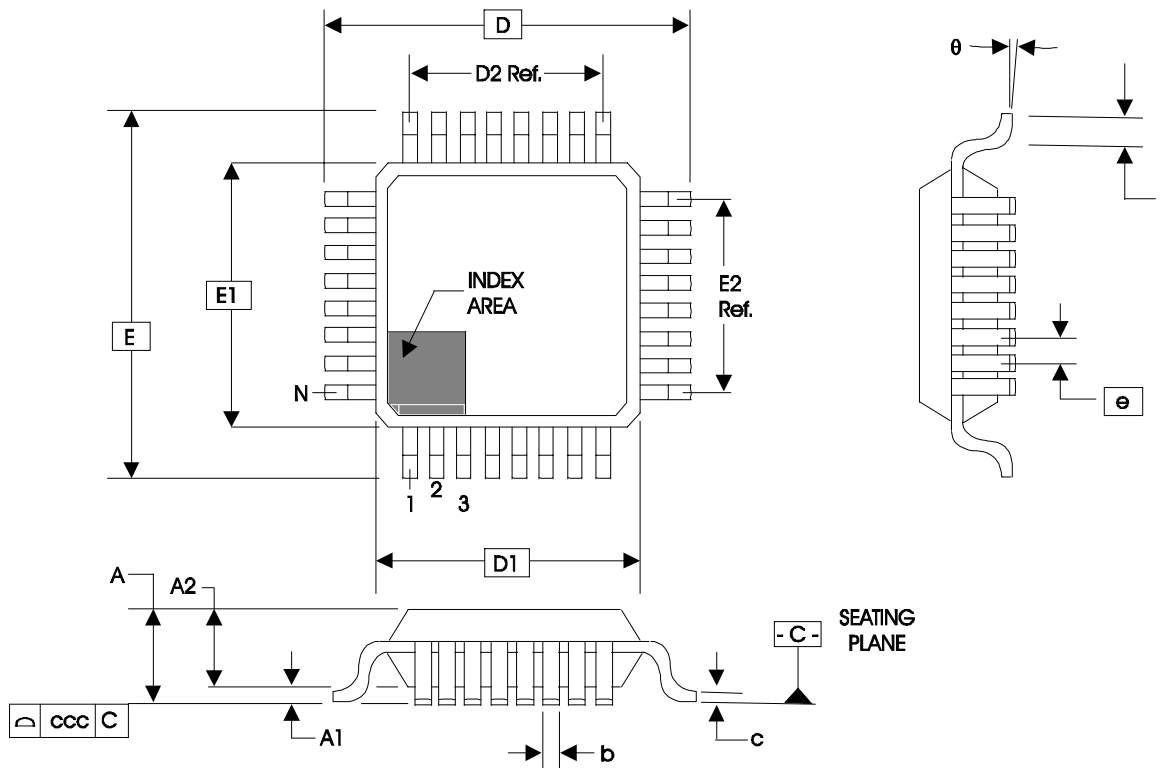

Table 8B. Package Dimensions 32 Lead LQFP

| JEDEC Variation: BBA | | | |
|-------------------------------|------------|---------|---------|
| All Dimensions in Millimeters | | | |
| Symbol | Minimum | Nominal | Maximum |
| N | 32 | | |
| A | | | 1.60 |
| A1 | 0.05 | 0.10 | 0.15 |
| A2 | 1.35 | 1.40 | 1.45 |
| b | 0.30 | | 0.45 |
| c | 0.09 | | 0.20 |
| D & E | 9.00 Basic | | |
| D1 & E1 | 7.00 Basic | | |
| e | 0.80 Basic | | |
| L | 0.45 | 0.60 | 0.75 |
| theta | 0° | | 7° |
| ccc | | | 0.10 |

Reference Document: JEDEC Publication 95, MS-026

Ordering Information

Table 9. Ordering Information

| Part/Order Number | Marking | Package | Shipping Packaging | Temperature |
|-------------------|--------------|---------------------------|--------------------|---------------|
| 854110AKILF | ICS54110AIL | "Lead-Free" 32 Lead VFQFN | Tray | -40°C to 85°C |
| 854110AKILFT | ICS54110AIL | "Lead-Free" 32 Lead VFQFN | 2500 Tape & Reel | -40°C to 85°C |
| 854110AYILF | ICS854110AIL | "Lead-Free" 32 Lead LQFP | Tray | -40°C to 85°C |
| 854110AYILFT | ICS854110AIL | "Lead-Free" 32 Lead LQFP | 1000 Tape & Reel | -40°C to 85°C |

NOTE: Parts that are ordered with an "LF" suffix to the part number are the Pb-Free configuration and are RoHS compliant.

Revision History Sheet

| Rev | Table | Page | Description of Change | Date |
|-----|-------|------|--|---------|
| B | T4A | 4 | Power Supply DC Characteristics Table - added I_{DD} spec of 30mA max. | 1/27/11 |

IMPORTANT NOTICE AND DISCLAIMER

RENESAS ELECTRONICS CORPORATION AND ITS SUBSIDIARIES (“RENESAS”) PROVIDES TECHNICAL SPECIFICATIONS AND RELIABILITY DATA (INCLUDING DATASHEETS), DESIGN RESOURCES (INCLUDING REFERENCE DESIGNS), APPLICATION OR OTHER DESIGN ADVICE, WEB TOOLS, SAFETY INFORMATION, AND OTHER RESOURCES “AS IS” AND WITH ALL FAULTS, AND DISCLAIMS ALL WARRANTIES, EXPRESS OR IMPLIED, INCLUDING, WITHOUT LIMITATION, ANY IMPLIED WARRANTIES OF MERCHANTABILITY, FITNESS FOR A PARTICULAR PURPOSE, OR NON-INFRINGEMENT OF THIRD-PARTY INTELLECTUAL PROPERTY RIGHTS.

These resources are intended for developers who are designing with Renesas products. You are solely responsible for (1) selecting the appropriate products for your application, (2) designing, validating, and testing your application, and (3) ensuring your application meets applicable standards, and any other safety, security, or other requirements. These resources are subject to change without notice. Renesas grants you permission to use these resources only to develop an application that uses Renesas products. Other reproduction or use of these resources is strictly prohibited. No license is granted to any other Renesas intellectual property or to any third-party intellectual property. Renesas disclaims responsibility for, and you will fully indemnify Renesas and its representatives against, any claims, damages, costs, losses, or liabilities arising from your use of these resources. Renesas' products are provided only subject to Renesas' Terms and Conditions of Sale or other applicable terms agreed to in writing. No use of any Renesas resources expands or otherwise alters any applicable warranties or warranty disclaimers for these products.

(Disclaimer Rev.1.01 Jan 2024)

Corporate Headquarters

TOYOSU FORESIA, 3-2-24 Toyosu,
Koto-ku, Tokyo 135-0061, Japan
www.renesas.com

Trademarks

Renesas and the Renesas logo are trademarks of Renesas Electronics Corporation. All trademarks and registered trademarks are the property of their respective owners.

Contact Information

For further information on a product, technology, the most up-to-date version of a document, or your nearest sales office, please visit www.renesas.com/contact-us/.

Looking for pricing, stock, or lifecycle information?

Click below to explore more details on WIN SOURCE:

- ⊖ [View 854110AKILF on WIN SOURCE](#)
- ⊖ [Renesas Electronics America](#) Information

Optimize Your Supply Chain with WIN SOURCE Solutions

- ✓ Global Sourcing Solution
- ✓ Obsolete Management
- ✓ Cost Control Management
- ✓ Shortage Management
- ✓ Alternative Solution
- ✓ Excess Inventory Management