



**THE DATASHEET OF  
85211AMI-01LF**



## GENERAL DESCRIPTION

The 85211I-01 is a low skew, high performance 1-to-2 Differential-to-HSTL Fanout Buffer. The CLK, nCLK pair can accept most standard differential input levels. The 85211I-01 is characterized to operate from a 3.3V power supply. Guaranteed output and part-to-part skew characteristics make the 85211I-01 ideal for those clock distribution applications demanding well defined performance and repeatability. For optimal performance, terminate all outputs.

## FEATURES

- Two differential HSTL compatible outputs
- One differential CLK, nCLK input pair
- CLK, nCLK pair can accept the following differential input levels: LVDS, LVPECL, HSTL, SSTL, HCSL
- Maximum output frequency: 700MHz
- Translates any single-ended input signal to HSTL levels with resistor bias on nCLK input
- Output skew: 30ps (maximum)
- Part-to-part skew: 250ps (maximum)
- Propagation delay: 1ns (maximum)
- Output crossover Voltage: 0.68V to 0.9V
- Output duty cycle: 49% - 51% up to 266.6MHz
- $V_{OH} = 1.4V$  (maximum)
- 3.3V operating supply
- -40°C to 85°C ambient operating temperature
- Available in lead-free RoHS-compliant package
- **For functional replacement use 8523**

## BLOCK DIAGRAM

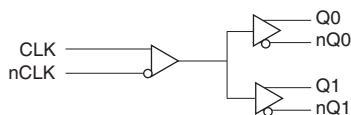

## PIN ASSIGNMENT

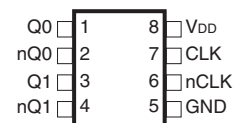

**85211I-01**  
**8-Lead SOIC**  
 3.90mm x 4.90mm x 1.37mm package body  
**M Package**  
 Top View

**TABLE 1. PIN DESCRIPTIONS**

Number	Name	Type		Description
1, 2	Q0, nQ0	Output		Differential output pair. HSTL interface levels.
3, 4	Q1, nQ1	Output		Differential output pair. HSTL interface levels.
5	GND	Power		Power supply ground.
6	nCLK	Input	Pullup/ Pulldown	Inverting differential clock input. $V_{DD}/2$ default when left floating.
7	CLK	Input	Pulldown	Non-inverting differential clock input.
8	$V_{DD}$	Power		Positive supply pin.

NOTE: *Pullup and Pulldown* refer to internal input resistors. See Table 2, Pin Characteristics, for typical values.

**TABLE 2. PIN CHARACTERISTICS**

Symbol	Parameter	Test Conditions	Minimum	Typical	Maximum	Units
$C_{IN}$	Input Capacitance			4		pF
$R_{PULLUP}$	Input Pullup Resistor			51		k $\Omega$
$R_{PULLDOWN}$	Input Pulldown Resistor			51		k $\Omega$

**TABLE 3. CLOCK INPUT FUNCTION TABLE**

Inputs		Outputs		Input to Output Mode	Polarity
CLK	nCLK	Q0, Q1	nQ0, nQ1		
0	0	LOW	HIGH	Differential to Differential	Non Inverting
1	1	HIGH	LOW	Differential to Differential	Non Inverting
0	Biased; NOTE 1	LOW	HIGH	Single Ended to Differential	Non Inverting
1	Biased; NOTE 1	HIGH	LOW	Single Ended to Differential	Non Inverting
Biased; NOTE 1	0	HIGH	LOW	Single Ended to Differential	Inverting
Biased; NOTE 1	1	LOW	HIGH	Single Ended to Differential	Inverting

NOTE 1: Please refer to the Application Information section, "Wiring the Differential Input to Accept Single Ended Levels".

**ABSOLUTE MAXIMUM RATINGS**

Supply Voltage, $V_{DD}$	4.6V
Inputs, $V_{DD}$	-0.5V to $V_{DD} + 0.5V$
Outputs, $V_{DD}$	-0.5V to $V_{DD} + 0.5V$
Package Thermal Impedance, $\theta_{JA}$	112.7°C/W (0 lfpm)
Storage Temperature, $T_{STG}$	-65°C to 150°C

NOTE: Stresses beyond those listed under Absolute Maximum Ratings may cause permanent damage to the device. These ratings are stress specifications only. Functional operation of product at these conditions or any conditions beyond those listed in the *DC Characteristics* or *AC Characteristics* is not implied. Exposure to absolute maximum rating conditions for extended periods may affect product reliability.

**TABLE 4A. POWER SUPPLY DC CHARACTERISTICS,  $V_{DD} = 3.3V \pm 5\%$ ,  $T_A = -40^\circ C$  TO  $85^\circ C$** 

Symbol	Parameter	Test Conditions	Minimum	Typical	Maximum	Units
$V_{DD}$	Power Supply Voltage		3.135	3.3	3.465	V
$I_{DD}$	Power Supply Current				22	mA

**TABLE 4B. DIFFERENTIAL DC CHARACTERISTICS,  $V_{DD} = 3.3V \pm 5\%$ ,  $T_A = -40^\circ C$  TO  $85^\circ C$** 

Symbol	Parameter	Test Conditions	Minimum	Typical	Maximum	Units
$I_{IH}$	Input High Current	nCLK	$V_{DD} = V_{IN} = 3.465V$		150	$\mu A$
		CLK	$V_{DD} = V_{IN} = 3.465V$		150	$\mu A$
$I_{IL}$	Input Low Current	nCLK	$V_{DD} = 3.465V, V_{IN} = 0V$	-150		$\mu A$
		CLK	$V_{DD} = 3.465V, V_{IN} = 0V$	-5		$\mu A$
$V_{PP}$	Peak-to-Peak Input Voltage		0.15		1.3	V
$V_{CMR}$	Common Mode Input Voltage; NOTE 1, 2		0.5		$V_{DD} - 0.85$	V

NOTE 1: For single ended applications the maximum input voltage for CLK and nCLK is  $V_{DD} + 0.3V$ .

NOTE 2: Common mode voltage is defined as  $V_{IH}$ .

**TABLE 4C. HSTL DC CHARACTERISTICS,  $V_{DD} = 3.3V \pm 5\%$ ,  $T_A = -40^\circ C$  TO  $85^\circ C$** 

Symbol	Parameter	Test Conditions	Minimum	Typical	Maximum	Units
$V_{OH}$	Output High Voltage; NOTE 1		1.0		1.4	V
$V_{OL}$	Output Low Voltage; NOTE 1		0		0.4	V
$V_{OX}$	Output Crossover Voltage		0.68		0.9	V
$V_{SWING}$	Peak-to-Peak Output Voltage Swing		0.6	1.0	1.4	V

NOTE 1: All outputs must be terminated with 50 $\Omega$  to ground.

**TABLE 5. AC CHARACTERISTICS,  $V_{DD} = 3.3V \pm 5\%$ ,  $T_A = -40^{\circ}C$  TO  $85^{\circ}C$** 

Symbol	Parameter	Test Conditions	Minimum	Typical	Maximum	Units
$f_{MAX}$	Output Frequency				700	MHz
$t_{PD}$	Propagation Delay; NOTE 1	$f \leq 600MHz$	0.7		1.0	ns
tsk(o)	Output Skew; NOTE 2, 4				30	ps
tsk(pp)	Part-to-Part Skew; NOTE 3, 4				250	ps
$t_R / t_F$	Output Rise/Fall Time	20% to 80%	200		500	ps
odc	Output Duty Cycle		48		52	%
		$f \leq 266.6MHz$	49		51	%

All parameters measured at 600MHz unless noted otherwise.

The cycle-to-cycle jitter on the input will equal the jitter on the output. The part does not add jitter.

NOTE 1: Measured from the differential input crossing point to the differential output crossing point.

NOTE 2: Defined as skew between outputs at the same supply voltage and with equal load conditions.

Measured at output differential cross points.

NOTE 3: Defined as skew between outputs on different devices operating at the same supply voltages and with equal load conditions. Using the same type of inputs on each device, the outputs are measured at the differential cross points.

NOTE 4: This parameter is defined in accordance with JEDEC Standard 65.

# PARAMETER MEASUREMENT INFORMATION

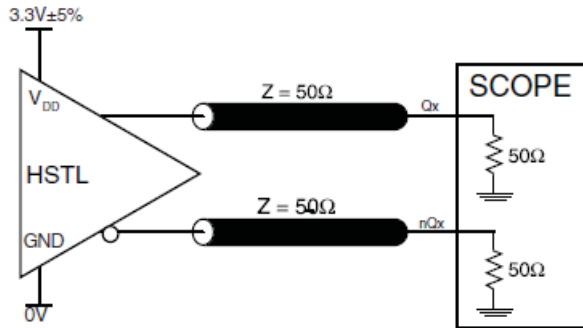

**3.3V OUTPUT LOAD AC TEST CIRCUIT**

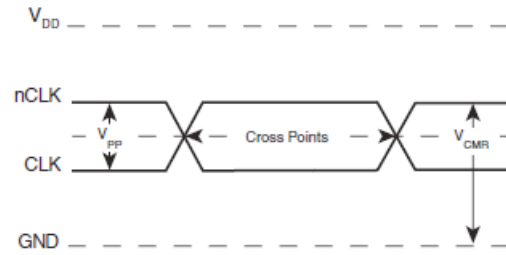

**DIFFERENTIAL INPUT LEVEL**

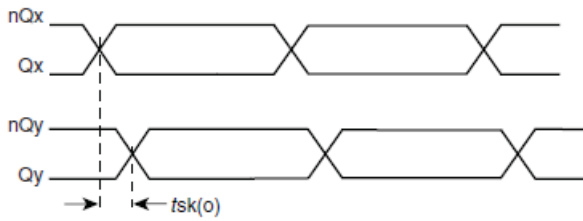

**OUTPUT SKEW**

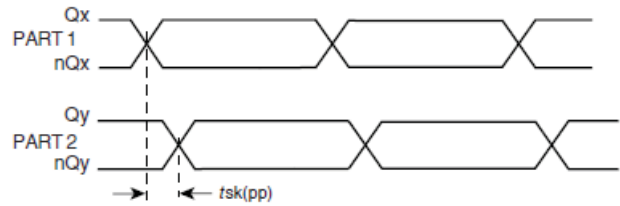

**PART-TO-PART SKEW**

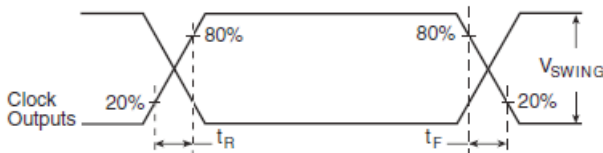

**OUTPUT RISE/FALL TIME**

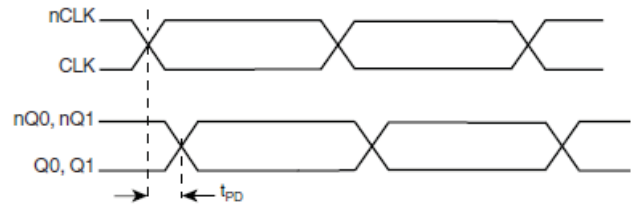

**PROPAGATION DELAY**

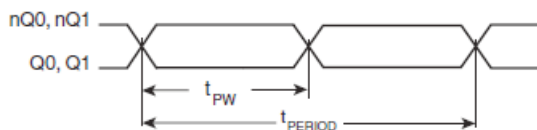

$$odc = \frac{t_{PW}}{t_{PERIOD}} \times 100\%$$

**OUTPUT DUTY CYCLE/PULSE WIDTH/PERIOD**

## APPLICATION INFORMATION

### WIRING THE DIFFERENTIAL INPUT TO ACCEPT SINGLE ENDED LEVELS

Figure 1 shows how the differential input can be wired to accept single ended levels. The reference voltage  $V_{REF} = V_{DD}/2$  is generated by the bias resistors R1, R2 and C1. This bias circuit should be located as close as possible to the input pin.

The ratio of R1 and R2 might need to be adjusted to position the  $V_{REF}$  in the center of the input voltage swing. For example, if the input clock swing is only 2.5V and  $V_{DD} = 3.3V$ ,  $V_{REF}$  should be 1.25V and  $R2/R1 = 0.609$ .

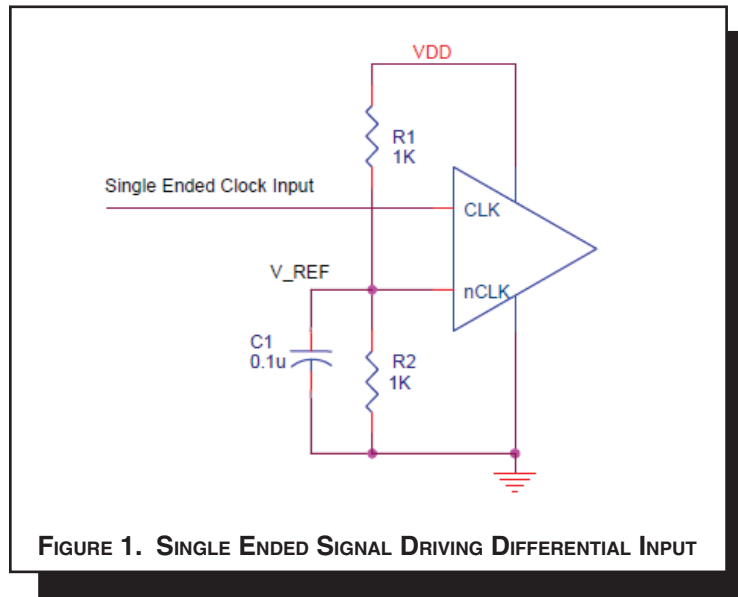

### SCHEMATIC EXAMPLE

Figure 2 shows a schematic example of 85211I-01. In this example, the input is driven by an ICS HiPerClockS HSTL driver. The decoupling capacitors should be physically located near

the power pin. For 85211I-01, the unused outputs need to be terminated.

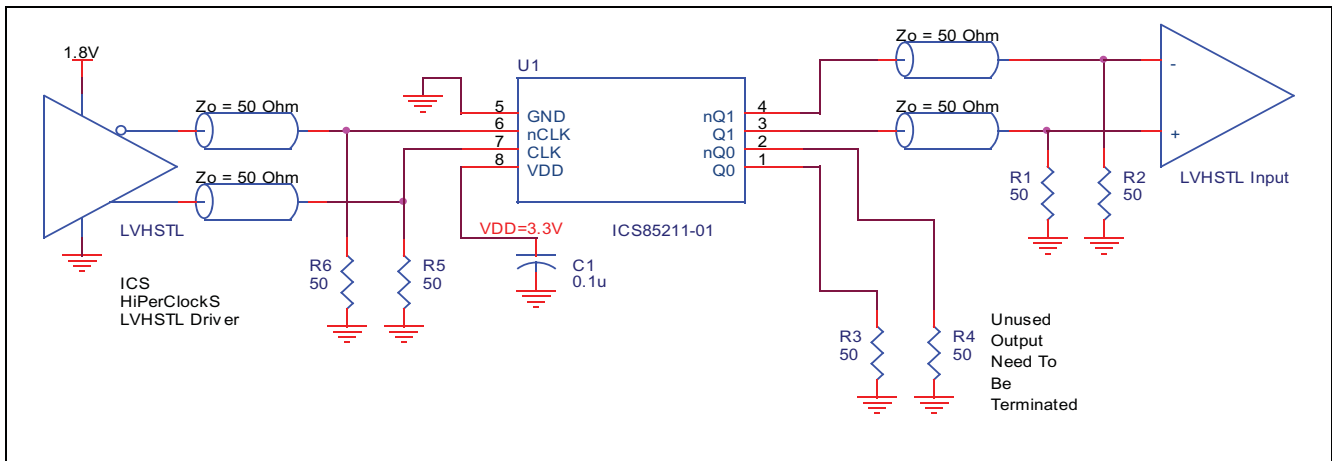

**RECOMMENDATIONS FOR UNUSED OUTPUT PINS**

**OUTPUTS:**

**HSTL OUTPUT**

All unused HSTL outputs can be left floating. We recommend that there is no trace attached. Both sides of the differential output pair should either be left floating or terminated.

**CLOCK INPUT INTERFACE**

The CLK /nCLK accepts differential input signals of both  $V_{SWING}$  and  $V_{OH}$  to meet the  $V_{PP}$  and  $V_{CMR}$  input requirements. *Figures 3A to 3D* show interface examples for the 852111-01 clock input driven by most common driver types. The input interfaces suggested here are examples only. Please consult with

the vendor of the driver components to confirm the driver termination requirement. For example in *Figure 3*, the input termination applies for HSTL drivers. If you are using an HSTL driver from another vendor, use their termination recommendation.

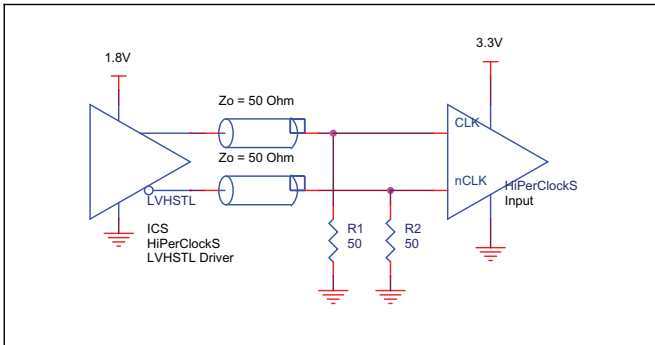

**FIGURE 3A. 852111-01 CLK/nCLK INPUT DRIVEN BY HSTL DRIVER**

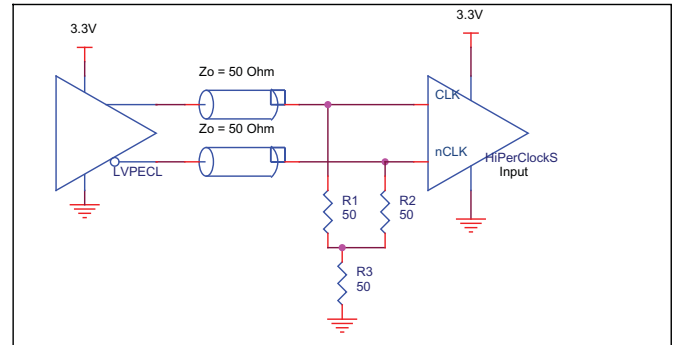

**FIGURE 3B. 852111-01 CLK/nCLK INPUT DRIVEN BY 3.3V LVPECL DRIVER (INTERFACE 1)**

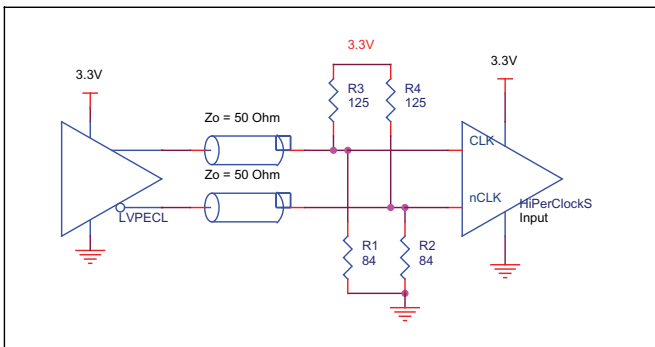

**FIGURE 3C. 852111-01 CLK/nCLK INPUT DRIVEN BY 3.3V LVPECL DRIVER (INTERFACE 2)**

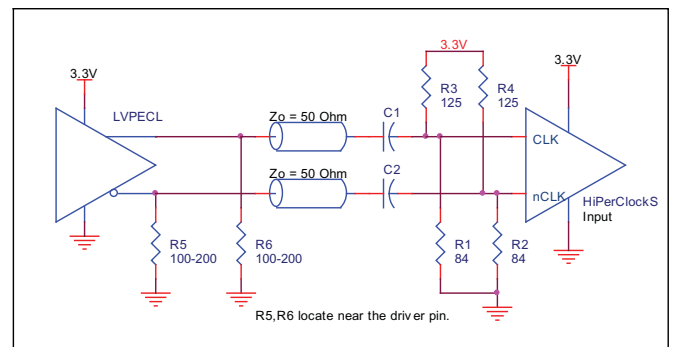

**FIGURE 3D. 852111-01 CLK/nCLK INPUT DRIVEN BY 3.3V LVPECL DRIVER WITH AC COUPLE**

## POWER CONSIDERATIONS

This section provides information on power dissipation and junction temperature for the 85211I-01. Equations and example calculations are also provided.

### 1. Power Dissipation.

The total power dissipation for the 85211I-01 is the sum of the core power plus the power dissipated in the load(s). The following is the power dissipation for  $V_{DD} = 3.3V + 5\% = 3.465V$ , which gives worst case results.

**NOTE:** Please refer to Section 3 for details on calculating power dissipated in the load.

- Power (core)<sub>MAX</sub> =  $V_{DD\_MAX} * I_{DD\_MAX} = 3.465V * 22mA = 76.2mW$
- Power (outputs)<sub>MAX</sub> = **82.34mW/Loaded Output pair**  
If all outputs are loaded, the total power is  $2 * 82.34mW = 164.7mW$

**Total Power**<sub>MAX</sub> (3.465V, with all outputs switching) =  $76.2mW + 164.7mW = 240.9mW$

### 2. Junction Temperature.

Junction temperature,  $T_j$ , is the temperature at the junction of the bond wire and bond pad and directly affects the reliability of the device. The maximum recommended junction temperature for the devices is 125°C.

The equation for  $T_j$  is as follows:  $T_j = \theta_{JA} * Pd\_total + T_A$

$T_j$  = Junction Temperature

$\theta_{JA}$  = Junction-to-Ambient Thermal Resistance

$Pd\_total$  = Total Device Power Dissipation (example calculation is in section 1 above)

$T_A$  = Ambient Temperature

In order to calculate junction temperature, the appropriate junction-to-ambient thermal resistance  $\theta_{JA}$  must be used. Assuming a moderate air flow of 200 linear feet per minute and a multi-layer board, the appropriate value is 103.3°C/W per Table 6 below. Therefore,  $T_j$  for an ambient temperature of 85°C with all outputs switching is:

$$85^\circ\text{C} + 0.241\text{W} * 103.3^\circ\text{C/W} = 110^\circ\text{C}. \text{ This is well below the limit of } 125^\circ\text{C}.$$

This calculation is only an example.  $T_j$  will obviously vary depending on the number of loaded outputs, supply voltage, air flow, and the type of board (single layer or multi-layer).

**TABLE 6. THERMAL RESISTANCE  $\theta_{JA}$  FOR 8-PIN SOIC, FORCED CONVECTION**

<b><math>\theta_{JA}</math> by Velocity (Linear Feet per Minute)</b>			
	<b>0</b>	<b>200</b>	<b>500</b>
Single-Layer PCB, JEDEC Standard Test Boards	153.3°C/W	128.5°C/W	115.5°C/W
Multi-Layer PCB, JEDEC Standard Test Boards	112.7°C/W	103.3°C/W	97.1°C/W

**NOTE:** Most modern PCB designs use multi-layered boards. The data in the second row pertains to most designs.

3. Calculations and Equations.

The purpose of this section is to derive the power dissipated into the load.

HSTL output driver circuit and termination are shown in *Figure 4*.

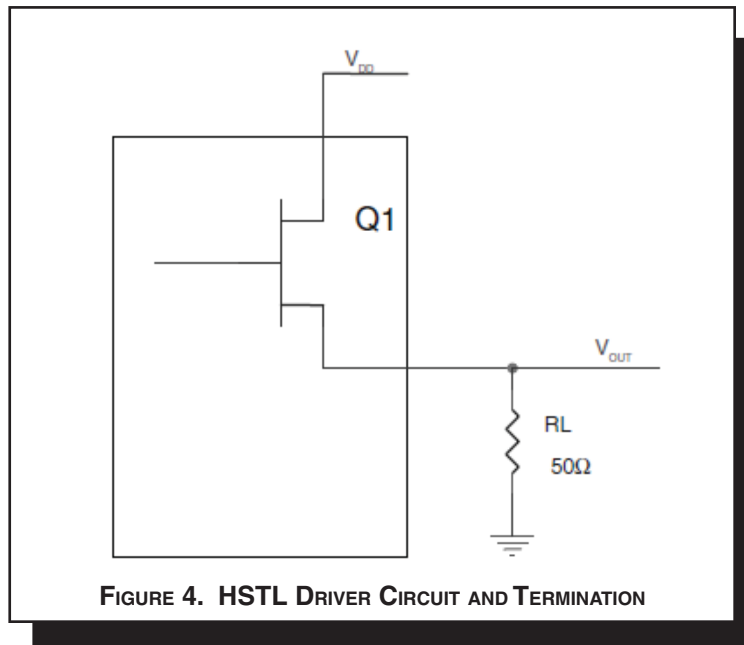

To calculate worst case power dissipation into the load, use the following equations which assume a 50Ω load.

Pd\_H is power dissipation when the output drives high.  
 Pd\_L is the power dissipation when the output drives low.

$$Pd\_H = (V_{OH\_MAX} / R_L) * (V_{DD\_MAX} - V_{OH\_MAX})$$

$$Pd\_L = (V_{OL\_MAX} / R_L) * (V_{DD\_MAX} - V_{OL\_MAX})$$

$$Pd\_H = (1.4V / 50\Omega) * (3.465V - 1.4V) = 57.82mW$$

$$Pd\_L = (0.4V / 50\Omega) * (3.465V - 0.4V) = 24.52mW$$

Total Power Dissipation per output pair = Pd\_H + Pd\_L = **82.34mW**

## RELIABILITY INFORMATION

TABLE 7.  $\theta_{JA}$  VS. AIR FLOW TABLE FOR 8 LEAD SOIC

$\theta_{JA}$ by Velocity (Linear Feet per Minute)			
	0	200	500
Single-Layer PCB, JEDEC Standard Test Boards	153.3°C/W	128.5°C/W	115.5°C/W
Multi-Layer PCB, JEDEC Standard Test Boards	112.7°C/W	103.3°C/W	97.1°C/W

**NOTE:** Most modern PCB designs use multi-layered boards. The data in the second row pertains to most designs.

### TRANSISTOR COUNT

The transistor count for 85211I-01 is: 411

PACKAGE OUTLINE - M SUFFIX FOR 8 LEAD SOIC

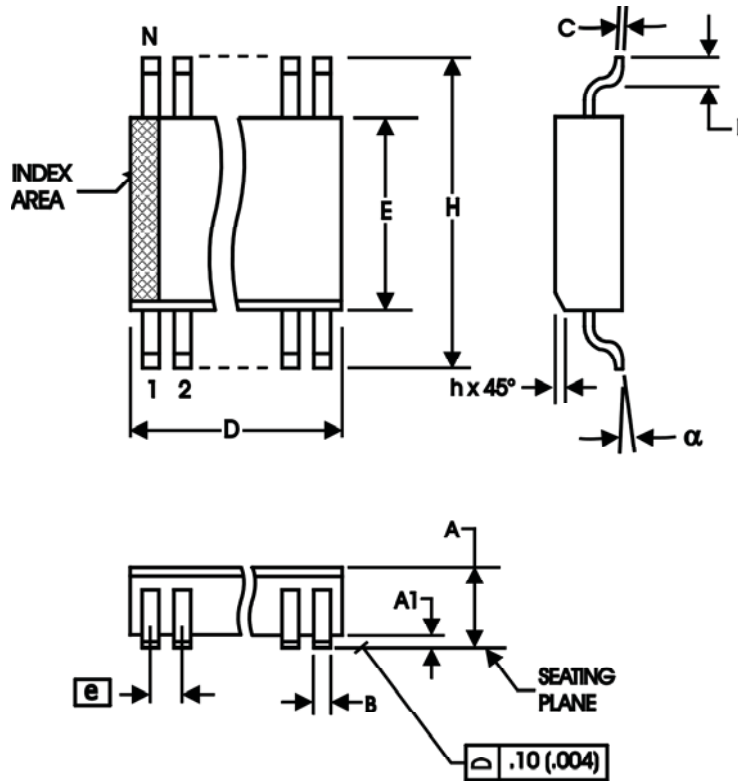

TABLE 8. PACKAGE DIMENSIONS

SYMBOL	Millimeters	
	MINIMUM	MAXIMUM
N	8	
A	1.35	1.75
A1	0.10	0.25
B	0.33	0.51
C	0.19	0.25
D	4.80	5.00
E	3.80	4.00
e	1.27 BASIC	
H	5.80	6.20
h	0.25	0.50
L	0.40	1.27
α	0°	8°

Reference Document: JEDEC Publication 95, MS-012

**TABLE 9. ORDERING INFORMATION**

<b>Part/Order Number</b>	<b>Marking</b>	<b>Package</b>	<b>Shipping Packaging</b>	<b>Temperature</b>
85211AMI-01LF	211AI01L	8 lead "Lead-Free" SOIC	tube	-40°C to 85°C
85211AMI-01LFT	211AI01L	8 lead "Lead-Free" SOIC	tape & reel	-40°C to 85°C

REVISION HISTORY SHEET				
Rev	Table	Page	Description of Change	Date
A	1	2	Throughout data sheet changed LVHSTL to HSTL.	7/16/03
	2	2	Changed nCLK Type from $V_{DD}/2$ to Pullup/Pulldown. Pin Characteristics Table - changed $C_{IN}$ 4pF max. to 4pF typical. Changed $R_{PULLUP}$ to $R_{PULLUP}/R_{PULLDOWN}$ , Pullup/Pulldown Resistors.	
A	T9	1	Features section - added Lead Free/RoHS bullet.	11/01/05
		7 12	Added <i>Recommendations for Unused Output Pins</i> . Ordering Information Table - added Lead-Free part number and marking.	
B	T9	12	Updated datasheet's header/footer with IDT from ICS.	8/4/10
		14	Removed ICS prefix from Part/Order Number column. Added Contact Page.	
B	T9	1	Features Section - removed reference to leaded devices.	6/12/15
		12	Ordering Information - removed leaded devices. Updated data sheet format.	
B	T9		Product Discontinuation Notice - Last time buy expires September 7, 2016.	3/10/16
		12	PDN N-16-02. Ordering Information - Deleted LF note below table.	



**Corporate Headquarters**

6024 Silver Creek Valley Road  
San Jose, California 95138

**Sales**

800-345-7015 or +408-284-8200  
Fax: 408-284-2775  
www.IDT.com

**Technical Support**

**email: [clocks@idt.com](mailto:clocks@idt.com)**

DISCLAIMER Integrated Device Technology, Inc. (IDT) and its subsidiaries reserve the right to modify the products and/or specifications described herein at any time and at IDT's sole discretion. All information in this document, including descriptions of product features and performance, is subject to change without notice. Performance specifications and the operating parameters of the described products are determined in the independent state and are not guaranteed to perform the same way when installed in customer products. The information contained herein is provided without representation or warranty of any kind, whether express or implied, including, but not limited to, the suitability of IDT's products for any particular purpose, an implied warranty of merchantability, or non-infringement of the intellectual property rights of others. This document is presented only as a guide and does not convey any license under intellectual property rights of IDT or any third parties.

IDT's products are not intended for use in applications involving extreme environmental conditions or in life support systems or similar devices where the failure or malfunction of an IDT product can be reasonably expected to significantly affect the health or safety of users. Anyone using an IDT product in such a manner does so at their own risk, absent an express, written agreement by IDT.

Integrated Device Technology, IDT and the IDT logo are registered trademarks of IDT. Other trademarks and service marks used herein, including protected names, logos and designs, are the property of IDT or their respective third party owners.

Copyright 2015. All rights reserved.

## IMPORTANT NOTICE AND DISCLAIMER

RENESAS ELECTRONICS CORPORATION AND ITS SUBSIDIARIES (“RENESAS”) PROVIDES TECHNICAL SPECIFICATIONS AND RELIABILITY DATA (INCLUDING DATASHEETS), DESIGN RESOURCES (INCLUDING REFERENCE DESIGNS), APPLICATION OR OTHER DESIGN ADVICE, WEB TOOLS, SAFETY INFORMATION, AND OTHER RESOURCES “AS IS” AND WITH ALL FAULTS, AND DISCLAIMS ALL WARRANTIES, EXPRESS OR IMPLIED, INCLUDING, WITHOUT LIMITATION, ANY IMPLIED WARRANTIES OF MERCHANTABILITY, FITNESS FOR A PARTICULAR PURPOSE, OR NON-INFRINGEMENT OF THIRD-PARTY INTELLECTUAL PROPERTY RIGHTS.

These resources are intended for developers who are designing with Renesas products. You are solely responsible for (1) selecting the appropriate products for your application, (2) designing, validating, and testing your application, and (3) ensuring your application meets applicable standards, and any other safety, security, or other requirements. These resources are subject to change without notice. Renesas grants you permission to use these resources only to develop an application that uses Renesas products. Other reproduction or use of these resources is strictly prohibited. No license is granted to any other Renesas intellectual property or to any third-party intellectual property. Renesas disclaims responsibility for, and you will fully indemnify Renesas and its representatives against, any claims, damages, costs, losses, or liabilities arising from your use of these resources. Renesas' products are provided only subject to Renesas' Terms and Conditions of Sale or other applicable terms agreed to in writing. No use of any Renesas resources expands or otherwise alters any applicable warranties or warranty disclaimers for these products.

(Disclaimer Rev.1.01 Jan 2024)

### Corporate Headquarters

TOYOSU FORESIA, 3-2-24 Toyosu,  
Koto-ku, Tokyo 135-0061, Japan  
[www.renesas.com](http://www.renesas.com)

### Trademarks

Renesas and the Renesas logo are trademarks of Renesas Electronics Corporation. All trademarks and registered trademarks are the property of their respective owners.

### Contact Information

For further information on a product, technology, the most up-to-date version of a document, or your nearest sales office, please visit [www.renesas.com/contact-us/](http://www.renesas.com/contact-us/).

## Looking for pricing, stock, or lifecycle information?

Click below to explore more details on WIN SOURCE:

-  [View 85211AMI-01LF on WIN SOURCE](#)
-  [Renesas Electronics America](#) Information

## Optimize Your Supply Chain with WIN SOURCE Solutions

-  Global Sourcing Solution
-  Obsolete Management
-  Cost Control Management
-  Shortage Management
-  Alternative Solution
-  Excess Inventory Management