



**THE DATASHEET OF
8430S10BYI-03LFT**



General Description

The 8430S10I-03 is a PLL-based clock generator specifically designed for Cavium Networks SoC processors. This high performance device is optimized to generate the processor core reference clock, the DDR reference clocks, the PCI/PCI-X bus clocks, and the clocks for both the Gigabit Ethernet MAC and PHY. The clock generator offers low-jitter, low-skew clock outputs, and edge rates that easily meet the input requirements for the CN30XX/CN31XX/CN38XX/CN58XX processors. The output frequencies are generated from a 25MHz external input source or an external 25MHz parallel resonant crystal. The extended temperature range of the 8430S10I-03 supports telecommunication, networking, and storage requirements.

Applications

- Systems using Cavium Processors
- CPE Gateway Design
- Home Media Servers
- 802.11n AP or Gateway
- Soho Secure Gateway
- Soho SME Gateway
- Wireless Soho and SME VPN Solutions
- Wired and Wireless Network Security
- Web Servers and Exchange Servers

Features

- One selectable differential output pair for DDR 533/400/667, LVPECL, LVDS interface levels
- Nine LVCMOS/ LVTTTL outputs, 23Ω typical output impedance
- Selectable external crystal or differential input source
- Crystal oscillator interface designed for 25MHz, parallel resonant crystal
- Differential input pair (PCLK, nPCLK) accepts LVPECL, LVDS, CML, SSTL input levels
- Internal resistor bias on nPCLK pin allows the user to drive PCLK input with external single-ended (LVCMOS/ LVTTTL) input levels
- Power supply modes:
CORE / OUTPUT
3.3V / 3.3V LVDS, LVPECL, LVCMOS
3.3V / 2.5V LVCMOS
- -40°C to 85°C ambient operating temperature
- Available in lead-free (RoHS 6) package

Pin Assignment

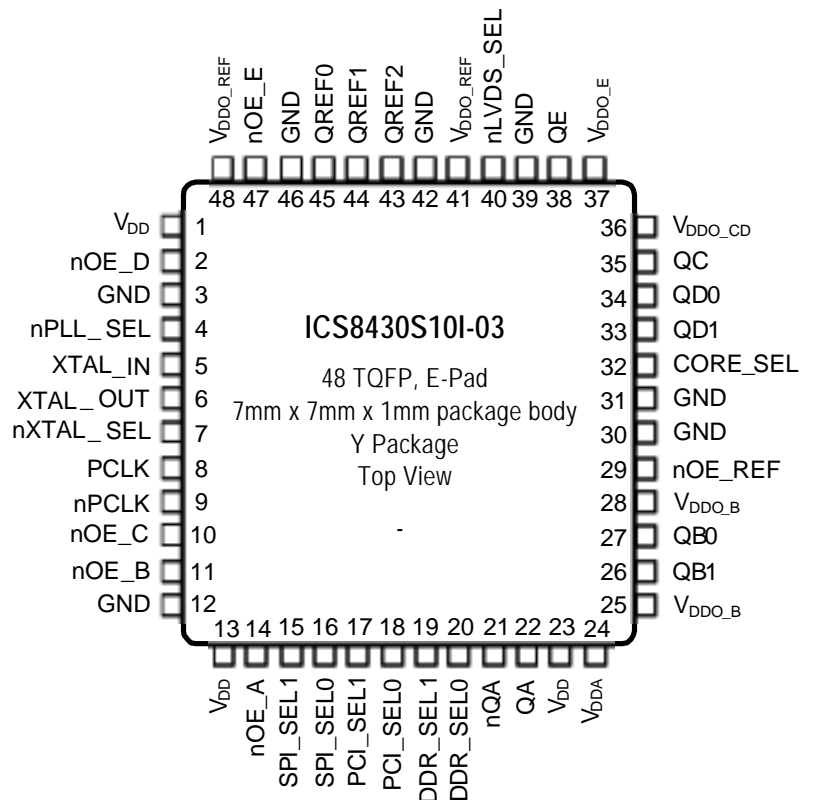

Block Diagram

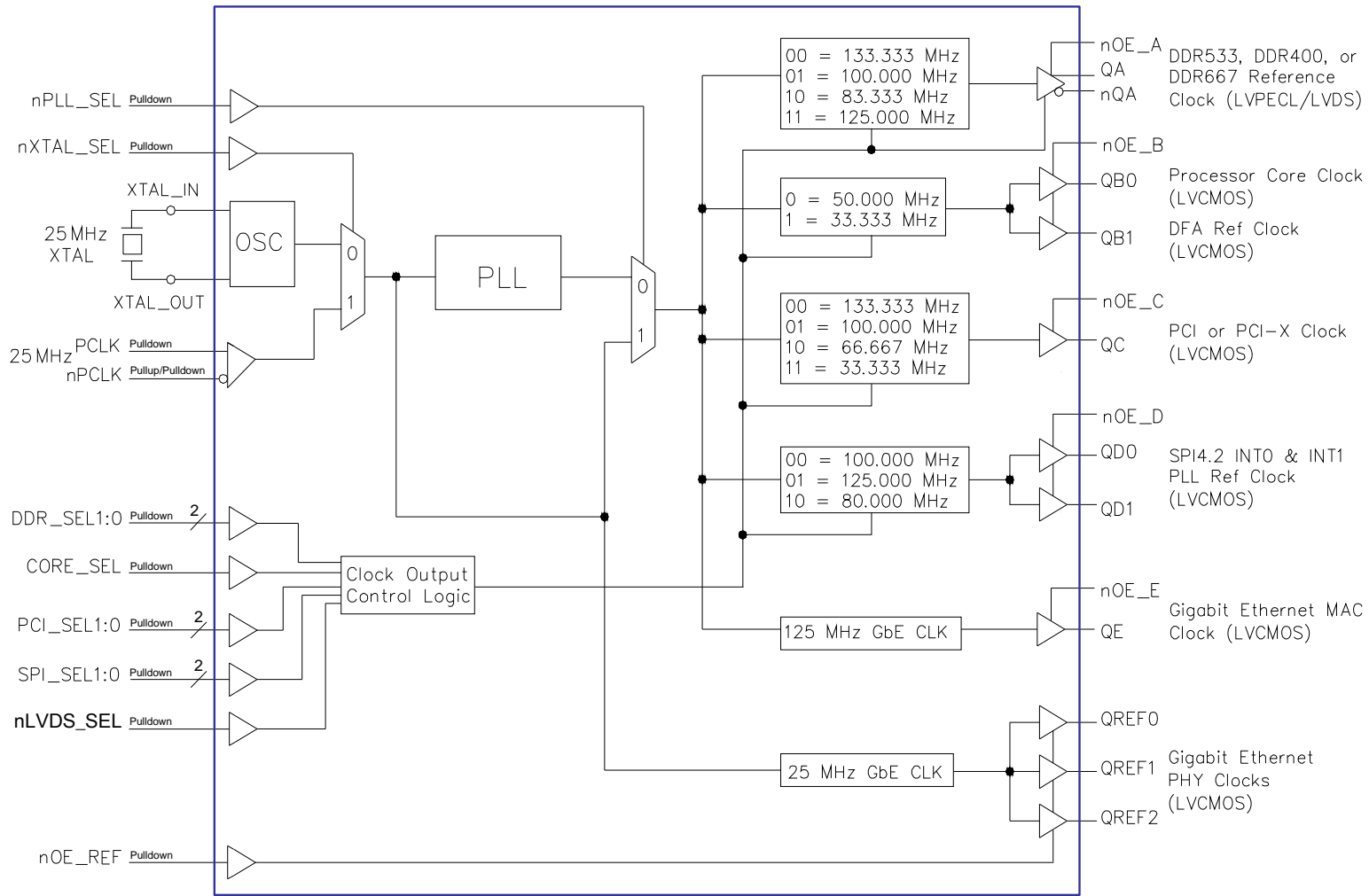

Table 1. Pin Descriptions

Number	Name	Type		Description
1, 13, 23	V _{DD}	Power		Core supply pins.
2	nOE_D	Input	Pulldown	Active LOW output enable for Bank D outputs. When logic HIGH, the outputs are high impedance (HI-Z). When logic LOW, the outputs are enabled. LVCMOS/LVTTL interface levels.
3, 12, 30, 31, 39, 42, 46	GND	Power		Power supply ground.
4	nPLL_SEL	Input	Pulldown	PLL bypass. When LOW, PLL is enabled. When HIGH, PLL is bypassed. LVCMOS/LVTTL interface levels.
5, 6	XTAL_IN, XTAL_OUT	Input		Parallel resonant crystal interface. XTAL_OUT is the output, XTAL_IN is the input.
7	nXTAL_SEL	Input	Pulldown	Selects XTAL input when LOW. Selects differential clock (PCLK, nPCLK) input when HIGH. LVCMOS/LVTTL interface levels.
8	PCLK	Input	Pulldown	Non-inverting differential clock input.
9	nPCLK	Input	Pullup/ Pulldown	Inverting differential clock input. Internal resistor bias to V _{DD} /2.
10	nOE_C	Input	Pulldown	Active LOW output enable for Bank C output. When logic HIGH, the output is high impedance (HI-Z). When logic LOW, QC output is enabled. LVCMOS/LVTTL interface levels.
11	nOE_B	Input	Pulldown	Active LOW output enable for Bank B outputs. When logic HIGH, the outputs are high impedance (HI-Z). When logic LOW, the outputs are enabled. LVCMOS/LVTTL interface levels.
14	nOE_A	Input	Pulldown	Active LOW output enable for Bank A outputs. LVCMOS/LVTTL interface levels.
15, 16	SPI_SEL1, SPI_SEL0	Input	Pulldown	Selects the SPI PLL clock reference frequency. See Table 3D.
17, 18	PCI_SEL1, PCI_SEL0	Input	Pulldown	Selects the PCI, PCI-X reference clock output frequency. See Table 3C. LVCMOS/LVTTL interface levels.
19, 20	DDR_SEL1, DDR_SEL0	Input	Pulldown	Selects the DDR reference clock output frequency. See Table 3B. LVCMOS/LVTTL interface levels.
21, 22	nQA, QA	Output		Differential output pair. Selectable between LVPECL and LVDS interface levels.
24	V _{DDA}	Power		Analog supply pin.
25, 28	V _{DDO_B}	Power		Bank B output supply pins. 3.3 V or 2.5V supply.
26, 27	QB1, QB0	Output		Single-ended Bank B outputs. LVCMOS/LVTTL interface levels.
29	nOE_REF	Input	Pulldown	Active LOW output enabled. When logic HIGH, the QREF[2:0] outputs are high impedance (HI-Z). When logic LOW, the QREF[2:0] outputs are enabled. LVCMOS/LVTTL interface levels.
32	CORE_SEL	Input	Pulldown	Selects the processor core clock output frequency. The output frequency is 50MHz when LOW, and 33.333MHz when HIGH. See Table 3A. LVCMOS/LVTTL interface levels.
33, 34	QD1, QD0	Output		Single-end Bank D outputs. LVCMOS/LVTTL interface levels.
35	QC	Output		Single-end Bank C output. LVCMOS/LVTTL interface levels.
36	V _{DDO_CD}	Power		Bank C and Bank D output supply pin. 3.3 V or 2.5V supply.

Pin descriptions continue on the next page.

Number	Name	Type		Description
37	V _{DDO_E}	Power		Bank E output supply pin. 3.3 V or 2.5V supply.
38	QE	Output		Single-end Bank E output. LVCMOS/LVTTL interface levels.
40	nLVDS_SEL	Input	Pulldown	Selects between LVDS and LVPECL interface levels on differential output pair QA and nQA. When LOW, LVDS levels are selected. When HIGH, LVPECL levels are selected. See Table 3E.
41, 48	V _{DDO_REF}	Power		Bank QREF output supply pins. 3.3 V or 2.5V supply.
43, 44, 45	QREF2, QREF1, QREF0	Output		Single-ended reference clock outputs. LVCMOS/LVTTL interface levels.
47	nOE_E	Input	Pulldown	Active LOW output enable for Bank E output. When logic HIGH, the output is high impedance (HI-Z). When logic LOW, the output is enabled. LVCMOS/LVTTL interface levels.

NOTE: Pullup and Pulldown refer to internal input resistors. See Table 2, Pin Characteristics, for typical values.

Table 2. Pin Characteristics

Symbol	Parameter	Test Conditions	Minimum	Typical	Maximum	Units
C _{IN}	Input Capacitance			2		pF
C _{PD}	Power Dissipation Capacitance (per output)	V _{DD} , V _{DDO_X} = 3.465V		10		pF
		V _{DD} = 3.465V, V _{DDO_X} = 2.625V		10		pF
R _{PULLUP}	Input Pullup Resistor			51		kΩ
R _{PULLDOWN}	Input Pulldown Resistor			51		kΩ
R _{OUT}	Output Impedance	QB[0:1], QC, QD[0:1], QE QREF[0:2]	V _{DDO_X} = 3.465V	23		Ω
		QB[0:1], QC, QD[0:1], QE QREF[0:2]	V _{DDO_X} = 2.625V	26		Ω

NOTE: V_{DDO_X} denotes V_{DDO_B}, V_{DDO_CD}, V_{DDO_E} and V_{DDO_REF}.

Function Tables

Table 3A. Control Input Function Table

Input	Output Frequency
CORE_SEL	QB[0:1]
0	50MHz (default)
1	33.333MHz

Table 3B. Control Input Function Table

Inputs		Output Frequency
DDR_SEL1	DDR_SEL0	QA, nQA
0	0	133.333MHz (default)
0	1	100.000MHz
1	0	83.333MHz
1	1	125.000MHz

Table 3C. Control Input Function Table

Inputs		Output Frequency
PCI_SEL1	PCI_SEL0	QC
0	0	133.333MHz (default)
0	1	100.000MHz
1	0	66.6667MHz
1	1	33.333MHz

Table 3D. Control Input Function Table

Inputs		Output Frequency
SPI_SEL1	SPI_SEL0	QD[0:1]
0	0	100.000MHz (default)
0	1	125.000MHz
1	0	80.000MHz

Table 3E. Control Input Function Table

Input	Output Levels
nLVDS_SEL	QA, nQA
0	LVDS (default)
1	LVPECL

Absolute Maximum Ratings

NOTE: Stresses beyond those listed under *Absolute Maximum Ratings* may cause permanent damage to the device. These ratings are stress specifications only. Functional operation of product at these conditions or any conditions beyond those listed in the *DC Characteristics* or *AC Characteristics* is not implied. Exposure to absolute maximum rating conditions for extended periods may affect product reliability.

Item	Rating
Supply Voltage, V_{DD}	4.6V
Inputs, V_I XTAL_IN Other Inputs	0V to V_{DD} -0.5V to $V_{DD} + 0.5V$
Outputs, V_O (LVCMOS)	-0.5V to $V_{DD} + 0.5V$
Outputs, I_O (LVDS) Continuous Current Surge Current	10mA 15mA
Outputs, I_O (LVPECL) Continuous Current Surge Current	50mA 100mA
Package Thermal Impedance, θ_{JA}	33.1°C/W (0 mps)
Storage Temperature, T_{STG}	-65°C to 150°C

DC Electrical Characteristics

Table 4A. LVCMOS Power Supply DC Characteristics, $V_{DD} = V_{DDO_X} = 3.3V \pm 5\%$, $T_A = -40^\circ\text{C}$ to 85°C

Symbol	Parameter	Test Conditions	Minimum	Typical	Maximum	Units
V_{DD}	Core Supply Voltage		3.135	3.3	3.465	V
V_{DDA}	Analog Supply Voltage		$V_{DD} - 0.20$	3.3	V_{DD}	V
V_{DDO_X}	Output Supply Voltage		3.135	3.3	3.465	V
I_{DD}	Power Supply Current				150	mA
I_{DDA}	Analog Supply Current				20	mA
I_{DDO_X}	Output Supply Current	No Load, nLVDS_SEL = 0			39	mA

NOTE: V_{DDO_X} denotes V_{DDO_B} , V_{DDO_CD} and V_{DDO_REF} .

Table 4B. LVCMOS Power Supply DC Characteristics, $V_{DD} = 3.3V \pm 5\%$, $V_{DDO_X} = 2.5V \pm 5\%$, $T_A = -40^\circ\text{C}$ to 85°C

Symbol	Parameter	Test Conditions	Minimum	Typical	Maximum	Units
V_{DD}	Core Supply Voltage		3.135	3.3	3.465	V
V_{DDA}	Analog Supply Voltage		$V_{DD} - 0.20$	3.3	V_{DD}	V
V_{DDO_X}	Output Supply Voltage		2.375	2.5	2.625	V
I_{DD}	Power Supply Current				150	mA
I_{DDA}	Analog Supply Current				20	mA
I_{DDO_X}	Output Supply Current	No Load, nLVDS_SEL = 0			27	mA

NOTE: V_{DDO_X} denotes V_{DDO_B} , V_{DDO_CD} and V_{DDO_REF} .

Table 4C. LVPECL Power Supply DC Characteristics, $V_{DD} = 3.3V \pm 5\%$, $T_A = -40^\circ\text{C}$ to 85°C

Symbol	Parameter	Test Conditions	Minimum	Typical	Maximum	Units
V_{DD}	Core Supply Voltage		3.135	3.3	3.465	V
V_{DDA}	Analog Supply Voltage		$V_{DD} - 0.20$	3.3	V_{DD}	V
I_{GND}	Power Supply Current	nLVDS_SEL = 1			186	mA
I_{DDA}	Analog Supply Current				20	mA

Table 4D. LVDS Power Supply DC Characteristics, $V_{DD} = 3.3V \pm 5\%$, $T_A = -40^\circ\text{C}$ to 85°C

Symbol	Parameter	Test Conditions	Minimum	Typical	Maximum	Units
V_{DD}	Core Supply Voltage		3.135	3.3	3.465	V
V_{DDA}	Analog Supply Voltage		$V_{DD} - 0.20$	3.3	V_{DD}	V
I_{DD}	Power Supply Current	nLVDS_SEL = 0			150	mA
I_{DDA}	Analog Supply Current				20	mA

Table 4E. LVCMOS/LVTTL DC Characteristics, $V_{DD} = 3.3V \pm 5\%$, $V_{DDO_X} = 3.3V \pm 5\%$ or $2.5V \pm 5\%$, $T_A = -40^\circ\text{C}$ to 85°C

Symbol	Parameter	Test Conditions	Minimum	Typical	Maximum	Units
V_{IH}	Input High Voltage		2.2		$V_{DD} + 0.3$	V
V_{IL}	Input Low Voltage		-0.3		0.8	V
I_{IH}	Input High Current	DDR_SEL[0:1], nPLL_SEL, nLVDS_SEL, PCI_SEL[0:1], nOE_REF, SPI_SEL[0:1], nOE_[A:E], nXTAL_SEL, CORE_SEL $V_{DD} = V_{IN} = 3.465V$			150	μA
I_{IL}	Input Low Current	DDR_SEL[0:1], nPLL_SEL, nLVDS_SEL, PCI_SEL[0:1], nOE_REF, SPI_SEL[0:1], nOE_[A:E], nXTAL_SEL, CORE_SEL $V_{DD} = 3.465V, V_{IN} = 0V$	-10			μA
V_{OH}	Output High Voltage	$V_{DDO_X} = 3.465V,$ $I_{OH} = -12mA$	2.6			V
		$V_{DDO_X} = 2.625V,$ $I_{OH} = -12mA$	1.8			V
V_{OL}	Output Low Voltage	$V_{DDO_X} = 3.465V,$ $I_{OL} = 12mA$			0.65	V
		$V_{DDO_X} = 2.625V,$ $I_{OL} = 12mA$			0.55	V

NOTE: V_{DDO_X} denotes V_{DDO_B} , V_{DDO_CD} , V_{DDO_E} and V_{DDO_REF} .

Table 4F. LVPECL DC Characteristics, $V_{DD} = 3.3V \pm 5\%$, $T_A = -40^{\circ}C$ to $85^{\circ}C$

Symbol	Parameter	Test Conditions	Minimum	Typical	Maximum	Units
I_{IH}	Input High Current	PCLK, nPCLK $V_{DD} = V_{IN} = 3.465V$			150	μA
I_{IL}	Input Low Current	PCLK $V_{DD} = 3.465V, V_{IN} = 0V$	-10			μA
		nPCLK $V_{DD} = 3.465V, V_{IN} = 0V$	-150			μA
V_{PP}	Peak-to-Peak Voltage		0.3		1.0	V
V_{CMR}	Common Mode Input Voltage; NOTE 1		GND + 1.5		V_{DD}	V
V_{OH}	Output High Voltage; NOTE 2		$V_{DD} - 1.4$		$V_{DD} - 0.9$	V
V_{OL}	Output Low Voltage; NOTE 2		$V_{DD} - 2.0$		$V_{DD} - 1.7$	V
V_{SWING}	Peak-to-Peak Output Voltage Swing		0.6		1.0	V

NOTE 1: Common mode input voltage is defined as V_{IH} .

NOTE 2: Outputs terminated with 50Ω to $V_{DD} - 2V$.

Table 4G. LVDS DC Characteristics, $V_{DD} = 3.3V \pm 5\%$, $T_A = -40^{\circ}C$ to $85^{\circ}C$

Symbol	Parameter	Test Conditions	Minimum	Typical	Maximum	Units
V_{OD}	Differential Output Voltage		300		600	mV
ΔV_{OD}	V_{OD} Magnitude Change				50	mV
V_{OS}	Offset Voltage		1.04	1.14	1.24	V
ΔV_{OS}	V_{OS} Magnitude Change				50	mV

Table 5. Crystal Characteristics

Parameter	Test Conditions	Minimum	Typical	Maximum	Units
Mode of Oscillation		Fundamental			
Frequency			25		MHz
Equivalent Series Resistance (ESR)				50	Ω
Shunt Capacitance				7	pF

NOTE: Characterized using an 18pF parallel resonant crystal.

AC Electrical Characteristics

Table 6. AC Characteristics, $V_{DD} = 3.3V \pm 5\%$, $V_{DDO_X} = 3.3V \pm 5\%$ or $2.5V \pm 5\%$, $T_A = -40^\circ C$ to $85^\circ C$

Symbol	Parameter	Test Conditions	Minimum	Typical	Maximum	Units	
f_{OUT}	Output Frequency	QA, nQA	DDR_SEL[1:0] = 00		133.333		MHz
		QA, nQA	DDR_SEL[1:0] = 01		100		MHz
		QA, nQA	DDR_SEL[1:0] = 10		83.333		MHz
		QA, nQA	DDR_SEL[1:0] = 11		125		MHz
		QBx	CORE_SEL = 0		50		MHz
		QBx	CORE_SEL = 1		33.333		MHz
		QC	PCI_SEL[1:0] = 00		133.333		MHz
		QC	PCI_SEL[1:0] = 01		100		MHz
		QC	PCI_SEL[1:0] = 10		66.667		MHz
		QC	PCI_SEL[1:0] = 11		33.333		MHz
		QDx	SPI_SEL[1:0] = 00		100		MHz
		QDx	SPI_SEL[1:0] = 01		125		MHz
		QDx	SPI_SEL[1:0] = 10		80		MHz
		QE			125		MHz
		QREFx			25		MHz
$t_{sk}(b)$	Bank Skew; NOTE 1, 2	QREFx	Using PCLK, nPCLK		25	ps	
$t_{sk}(pp)$	Part-to-Part Skew; NOTE 2, 3	QREFx	Using PCLK, nPCLK		350	ps	
$t_{jit}(\emptyset)$	RMS Phase Jitter, (Random); NOTE 5	QREFx	25MHz (10kHz to 5MHz)	0.637		ps	
		QE	125MHz (1.875MHz to 20MHz)	0.557		ps	
$t_{jit}(per)$	Period Jitter (pk-pk); NOTE 4, 11	QA, nQA	133.33MHz; NOTE 6		115	ps	
			100MHz; NOTE 7		115	ps	
			133.33MHz; NOTE 8		115	ps	
			100MHz; NOTE 9		115	ps	
			83.33MHz; NOTE 10		115	ps	
		QBx	50MHz; NOTE 6		95	ps	
			50MHz; NOTE 7		95	ps	
			50MHz; NOTE 8		95	ps	
			50MHz; NOTE 9		95	ps	
			50MHz; NOTE 10		95	ps	
		QC	133.33MHz; NOTE 6		90	ps	
			133.33MHz; NOTE 9		90	ps	
		QDx	100MHz; NOTE 7		95	ps	
			125MHz; NOTE 8		95	ps	
			125MHz; NOTE 10		95	ps	
		QE	125MHz; NOTE 6		90	ps	
125MHz; NOTE 8			90	ps			
125MHz; NOTE 9			90	ps			
125MHz; NOTE 10			90	ps			

Continued on next page.

Symbol	Parameter	Test Conditions	Minimum	Typical	Maximum	Units		
t _{jit} (hper)	RMS Half-Period Jitter; NOTE 2, 4	QA, nQA	133.33MHz; NOTE 6			30	ps	
			100MHz; NOTE 7			30	ps	
			133.33MHz; NOTE 8			30	ps	
			100MHz; NOTE 9			30	ps	
			83.33MHz; NOTE 10			30	ps	
t _R / t _F	Output Rise/Fall Time	QA, nQA	10% to 90%			150	ps	
		QBx, QC, QDx, QE, QREFx				200	900	ps
odc	Output Duty Cycle	QA, nQA				48	52	%
		QBx, QC, QE, QREFx				48	52	%
		QDx				48	52	%
t _{LOCK}	Lock Time					55	ms	

NOTE: Electrical parameters are guaranteed over the specified ambient operating temperature range, which is established when the device is mounted in a test socket with maintained transverse airflow greater than 500 lfm. The device will meet specifications after thermal equilibrium has been reached under these conditions.

NOTE: All parameters measured at maximum f_{OUT}, unless noted otherwise.

NOTE: All parameters are characterized using crystal input, unless noted otherwise.

NOTE: V_{DDO_X} denotes V_{DDO_B}, V_{DDO_CD}, V_{DDO_E} and V_{DDO_REF}.

NOTE 1: Defined as skew within a bank of outputs at the same supply voltage and with equal load conditions.

NOTE 2: This parameter is defined in accordance with JEDEC Standard 65.

NOTE 3: Defined as skew between outputs on different devices operating at the same supply voltage, same temperature and with equal load conditions. Using the same type of inputs on each device, the outputs are measured at V_{DDO_REF}/2.

NOTE 4: This parameter is measured at the crosspoint for differential and V_{DDO_X}/2 single-ended signals.

NOTE 5: Refer to the phase noise plot.

NOTE 6: DDR_SEL[1:0] = 00: QA, nQA = 133.33MHz, QBx = 50MHz, QC = 133.33MHz, QDx = OFF, QE = 125MHz and QREFx = 25MHz.

NOTE 7: DDR_SEL[1:0] = 01: QA, nQA = 100MHz, QBx = 50MHz, QC = OFF, QDx = 100MHz, QE = OFF and QREFx = 25MHz.

NOTE 8: DDR_SEL[1:0] = 00: QA, nQA = 133.33MHz, QBx = 50MHz, QC = OFF, QDx = 125MHz, QE = 125MHz and QREFx = 25MHz.

NOTE 9: DDR_SEL[1:0] = 01: QA, nQA = 100MHz, QBx = 50MHz, QC = 133.33MHz, QDx = OFF, QE = 125MHz and QREFx = 25MHz.

NOTE 10: DDR_SEL[1:0] = 10: QA, nQA = 83.33MHz, QBx = 50MHz, QC = OFF, QDx = 125MHz, QE = 125MHz and QREFx = 25MHz.

NOTE 11: This parameter is measured at 10K cycles.

Typical Phase Noise at 125MHz (QE output)

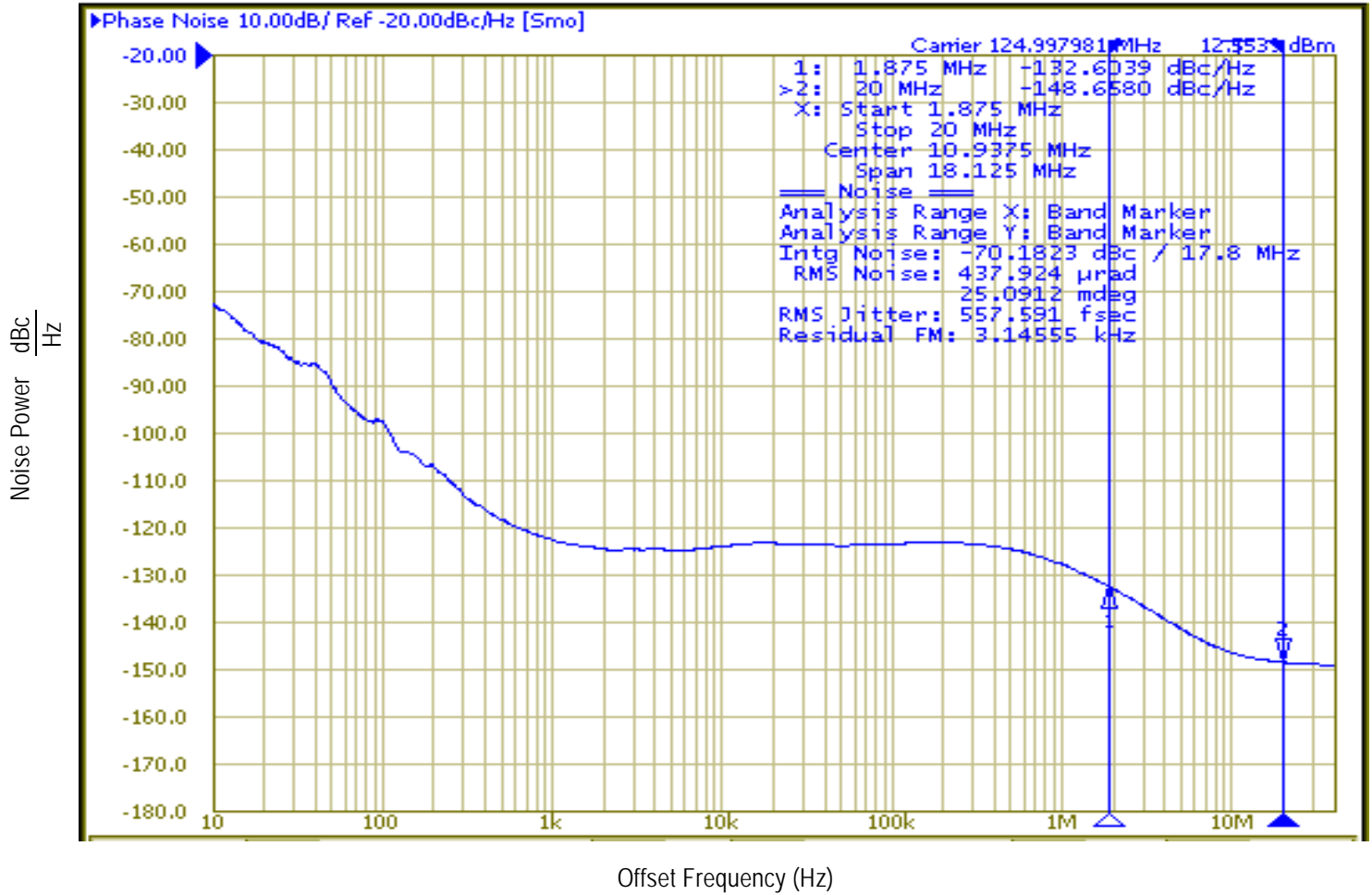

Typical Phase Noise at 25MHz (QREF output)

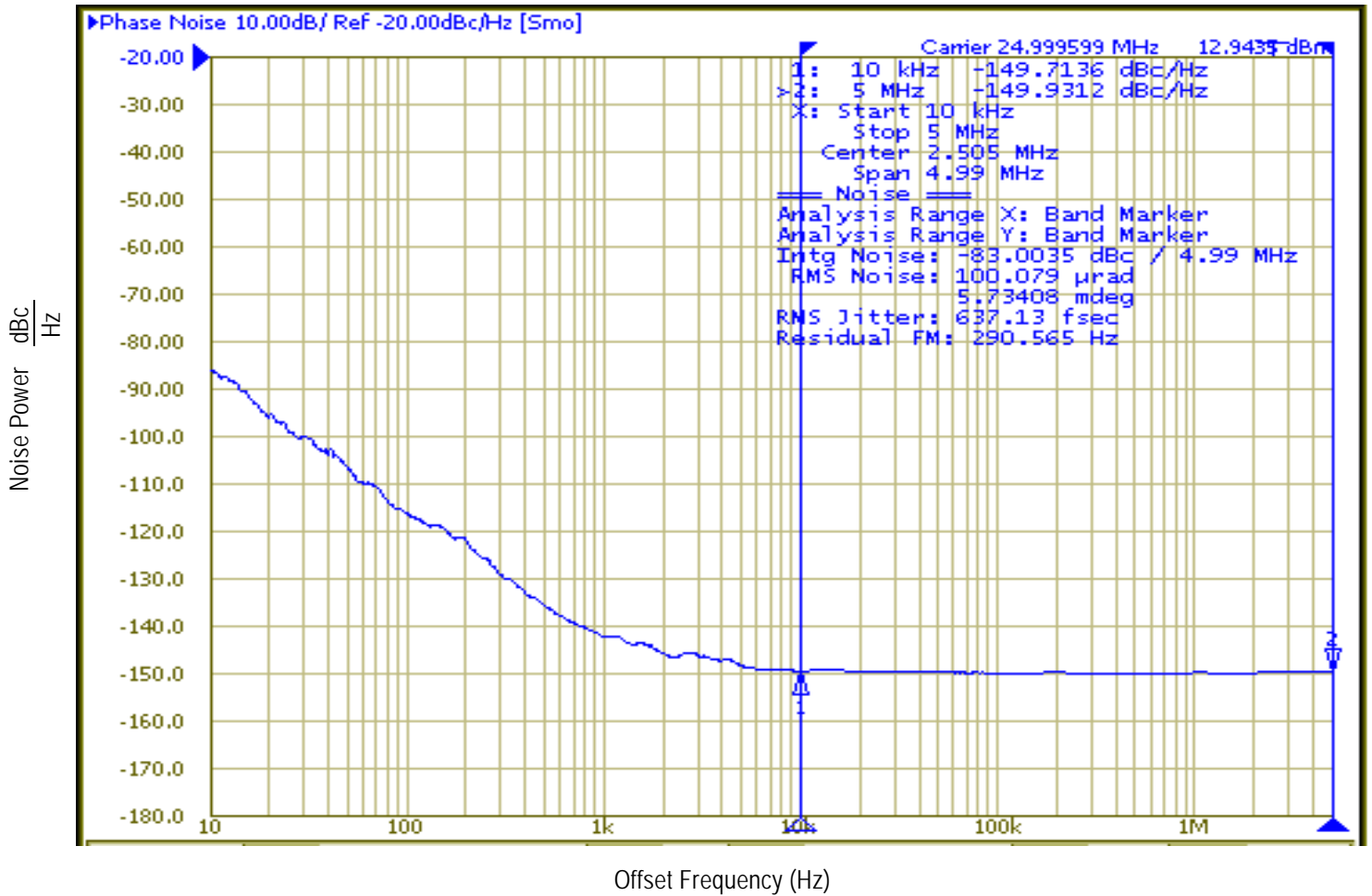

Parameter Measurement Information

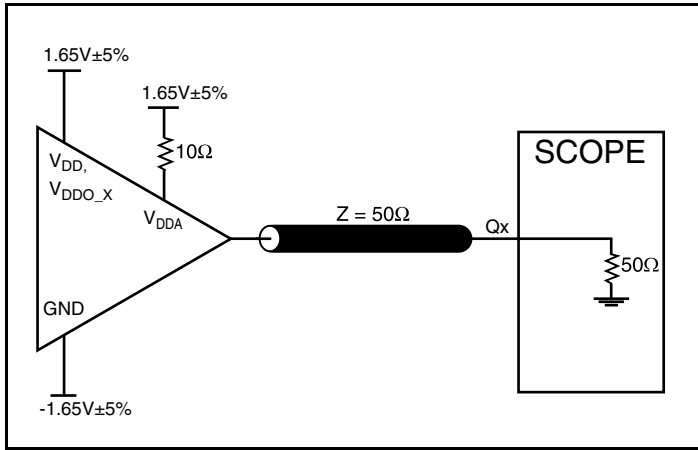

3.3V Core/3.3V LVCMOS Output Load AC Test Circuit

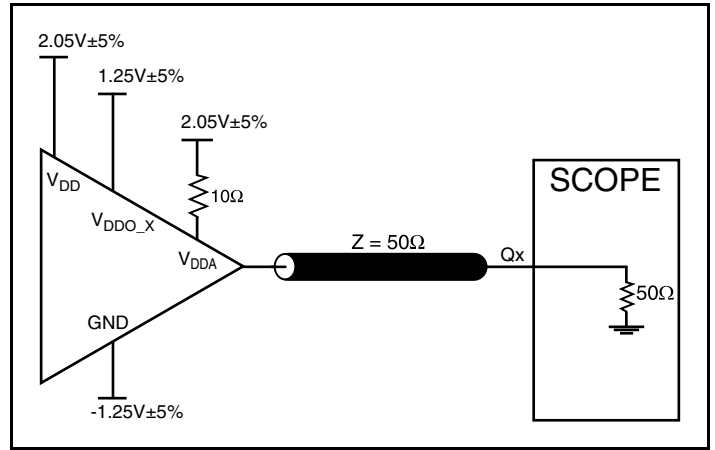

3.3V Core/2.5V LVCMOS Output Load AC Test Circuit

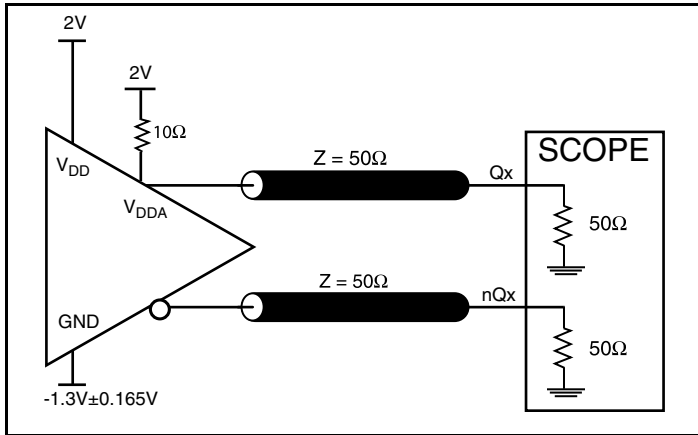

3.3V Core/3.3V LVPECL Output Load AC Test Circuit

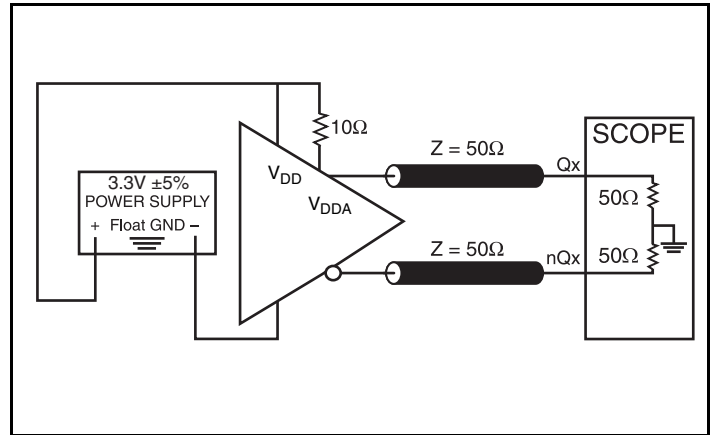

3.3V Core/3.3V LVDS Output Load AC Test Circuit

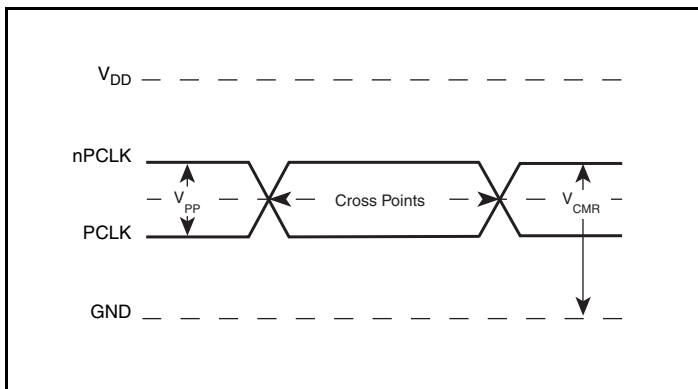

Differential Input Level

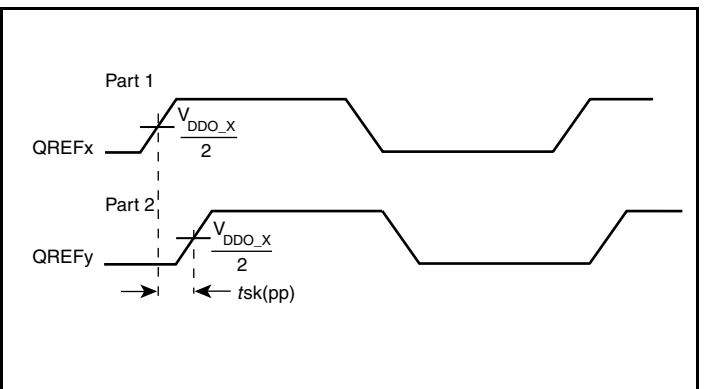

LVCMOS Part-to-Part Skew

Parameter Measurement Information, continued

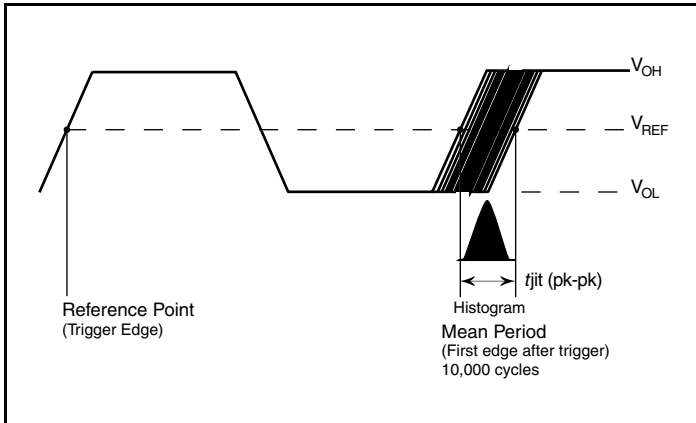

Period Jitter, Peak-to-Peak

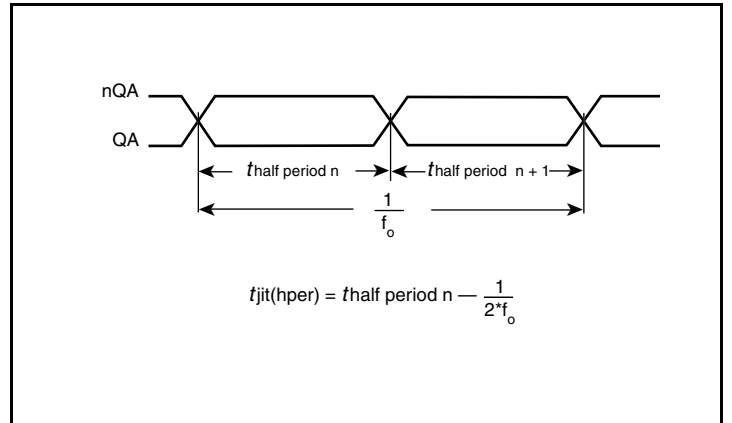

Half Period Jitter

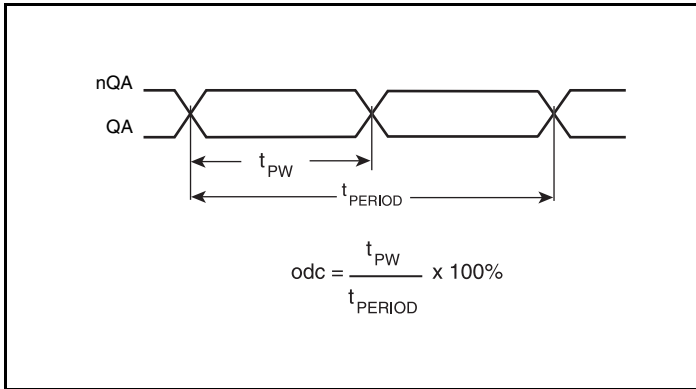

Differential Output Duty Cycle/Pulse Width/Period

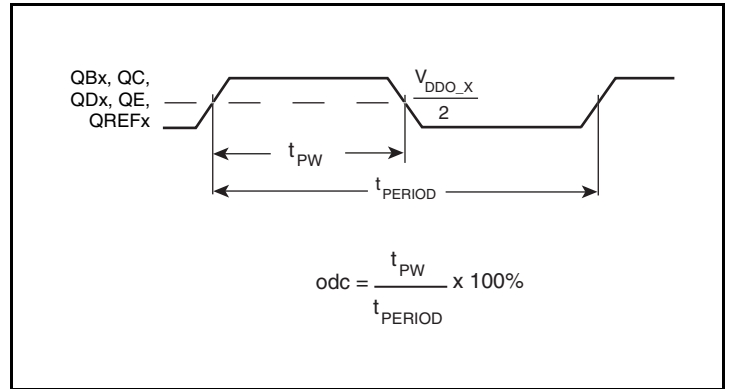

LVCMOS Output Duty Cycle/Pulse Width/Period

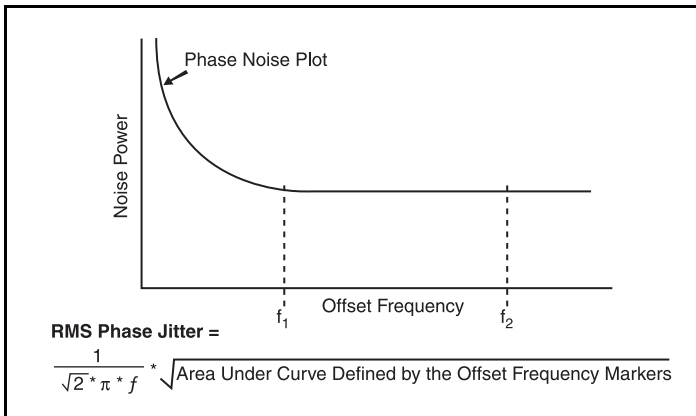

RMS Phase Jitter

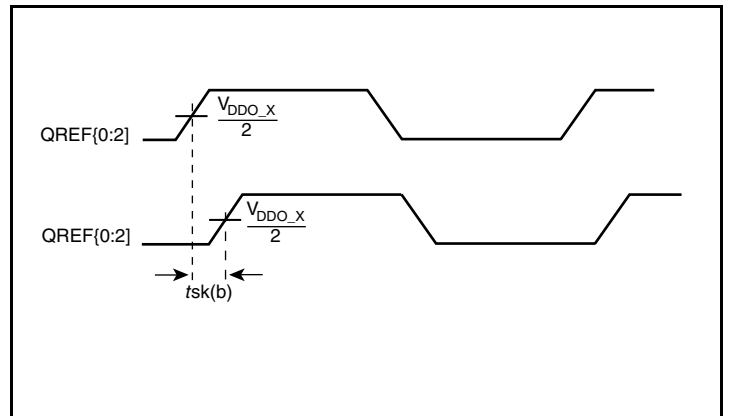

LVCMOS Bank Skew

Parameter Measurement Information, continued

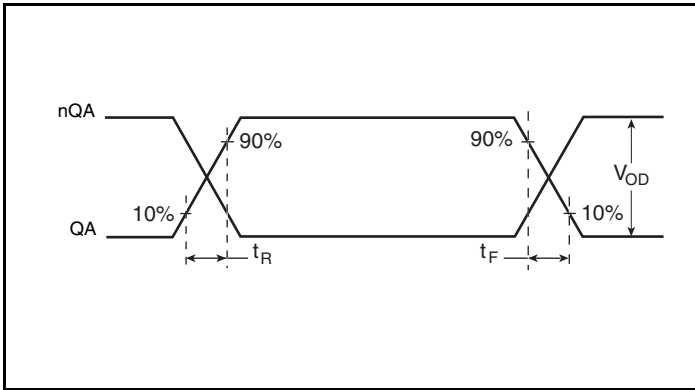

LVDS Output Rise/Fall Time

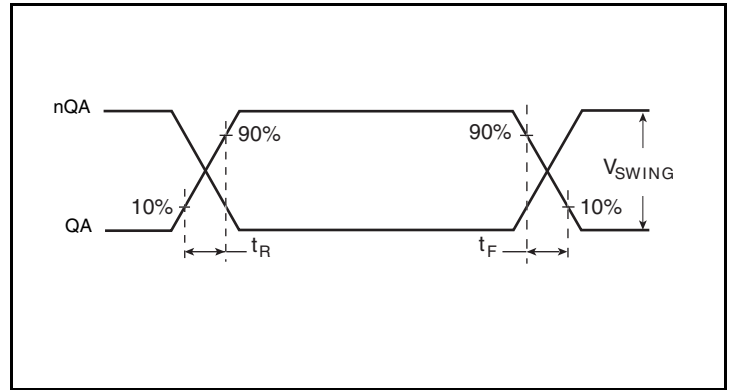

LVPECL Output Rise/Fall Time

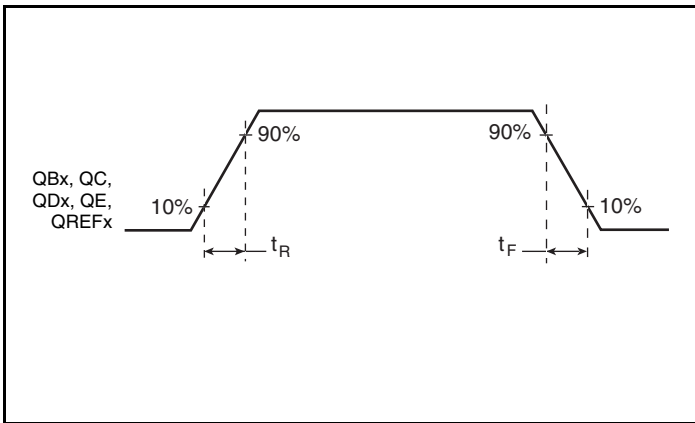

LVCMOS Output Rise/Fall Time

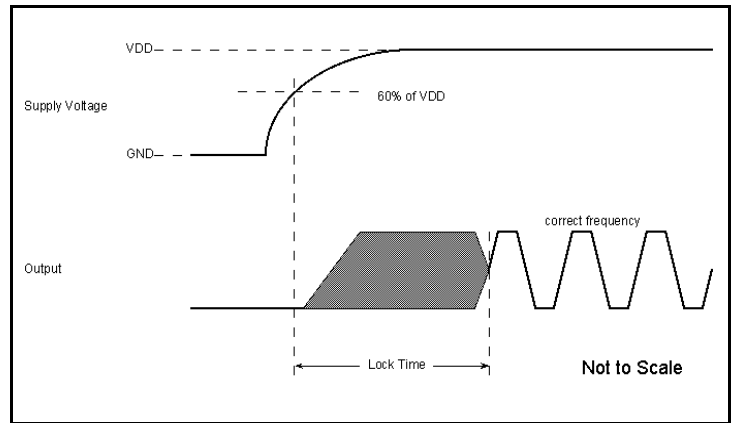

Lock Time

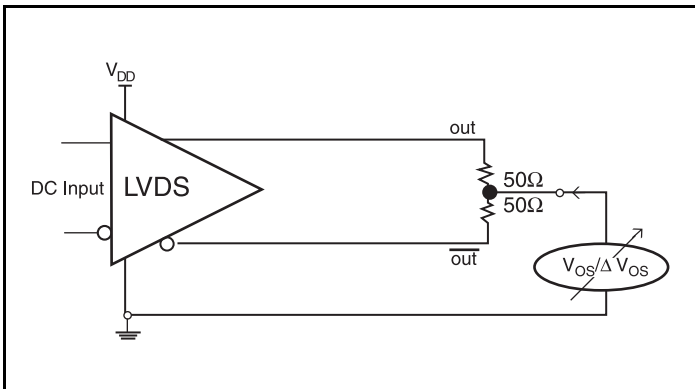

Offset Voltage Setup

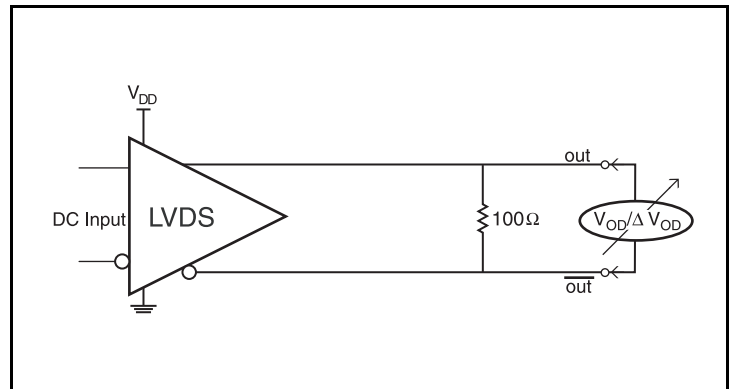

Differential Output Voltage Setup

Applications Information

Recommendations for Unused Input and Output Pins

Inputs:

PCLK/nPCLK Inputs

For applications not requiring the use of the differential input, both PCLK and nPCLK can be left floating. Though not required, but for additional protection, a 1kΩ resistor can be tied from PCLK to ground.

Crystal Inputs

For applications not requiring the use of the crystal oscillator input, both XTAL_IN and XTAL_OUT can be left floating. Though not required, but for additional protection, a 1kΩ resistor can be tied from XTAL_IN to ground.

LVC MOS Control Pins

All control pins have internal pulldowns; additional resistance is not required but can be added for additional protection. A 1kΩ resistor can be used.

Outputs:

LVPECL Outputs

The unused LVPECL output pair can be left floating. We recommend that there is no trace attached. Both sides of the differential output pair should either be left floating or terminated.

LVDS Outputs

The unused LVDS output pair can be either left floating or terminated with 100Ω across. If they are left floating, there should be no trace attached.

LVC MOS Outputs

All unused LVC MOS output can be left floating. There should be no trace attached.

Wiring the Differential Input to Accept Single-Ended Levels

Figure 1 shows how a differential input can be wired to accept single ended levels. The reference voltage $V_{REF} = V_{DD}/2$ is generated by the bias resistors R1 and R2. The bypass capacitor (C1) is used to help filter noise on the DC bias. This bias circuit should be located as close to the input pin as possible. The ratio of R1 and R2 might need to be adjusted to position the V_{REF} in the center of the input voltage swing. For example, if the input clock swing is 2.5V and $V_{DD} = 3.3V$, R1 and R2 value should be adjusted to set V_{REF} at 1.25V. The values below are for when both the single ended swing and V_{DD} are at the same voltage. This configuration requires that the sum of the output impedance of the driver (R_o) and the series resistance (R_s) equals the transmission line impedance. In addition, matched termination at the input will attenuate the signal in half. This can be done in one of two ways. First, R3 and R4 in parallel should equal

the transmission line impedance. For most 50Ω applications, R3 and R4 can be 100Ω. The values of the resistors can be increased to reduce the loading for slower and weaker LVC MOS driver. When using single-ended signaling, the noise rejection benefits of differential signaling are reduced. Even though the differential input can handle full rail LVC MOS signaling, it is recommended that the amplitude be reduced. The datasheet specifies a lower differential amplitude, however this only applies to differential signals. For single-ended applications, the swing can be larger, however V_{IL} cannot be less than -0.3V and V_{IH} cannot be more than $V_{DD} + 0.3V$. Though some of the recommended components might not be used, the pads should be placed in the layout. They can be utilized for debugging purposes. The datasheet specifications are characterized and guaranteed by using a differential signal.

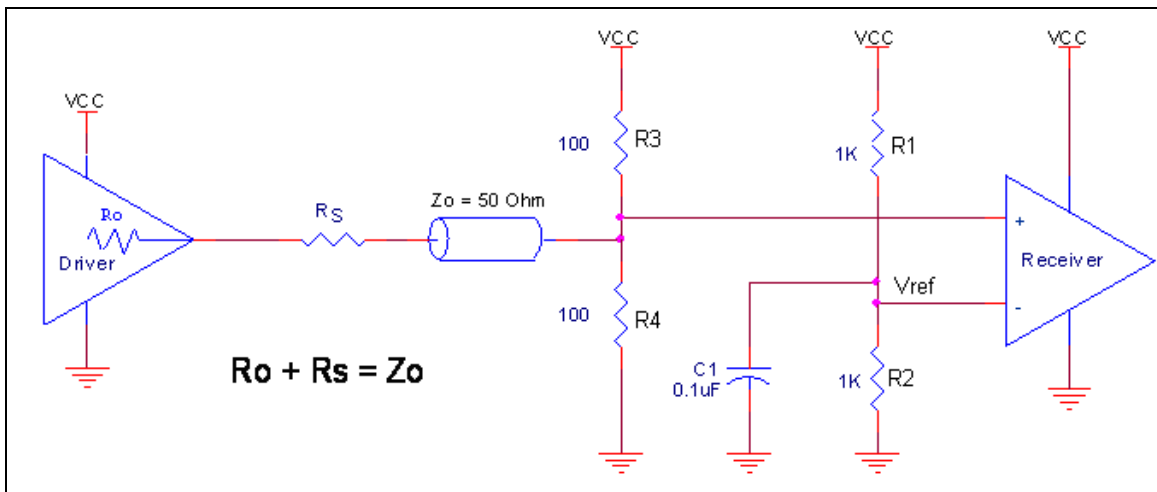

Figure 1. Recommended Schematic for Wiring a Differential Input to Accept Single-ended Levels

3.3V LVPECL Differential Clock Input Interface

The PCLK /nPCLK accepts LVPECL, LVDS, CML, SSTL and other differential signals. The differential signals must meet the V_{PP} and V_{CMR} input requirements. Figures 2A to 2E show interface examples for the PCLK/ nPCLK input driven by the most common driver types.

The input interfaces suggested here are examples only. If the driver is from another vendor, use their termination recommendation. Please consult with the vendor of the driver component to confirm the driver termination requirements.

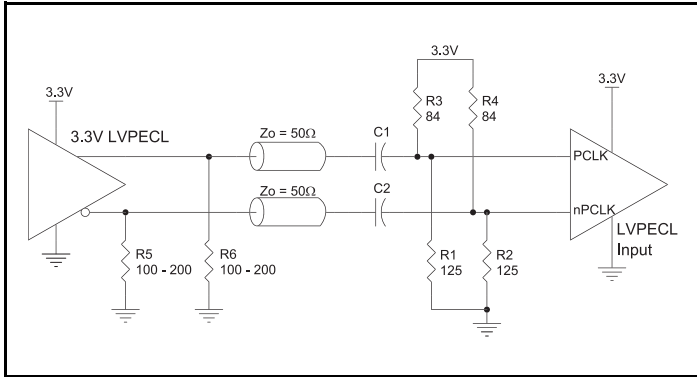

Figure 2A. PCLK/nPCLK Input Driven by a 3.3V LVPECL Driver with AC Couple

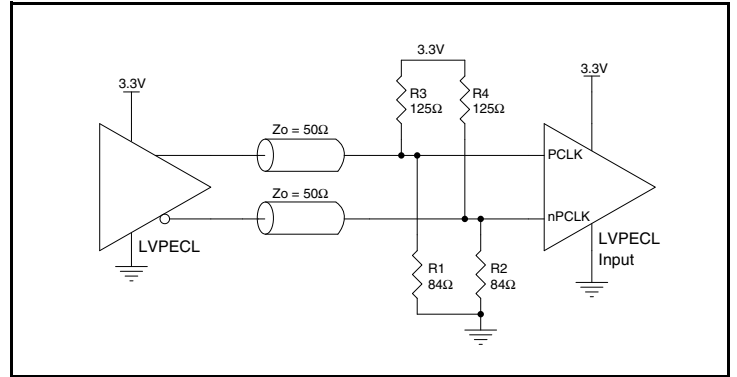

Figure 2B. PCLK/nPCLK Input Driven by a 3.3V LVPECL Driver

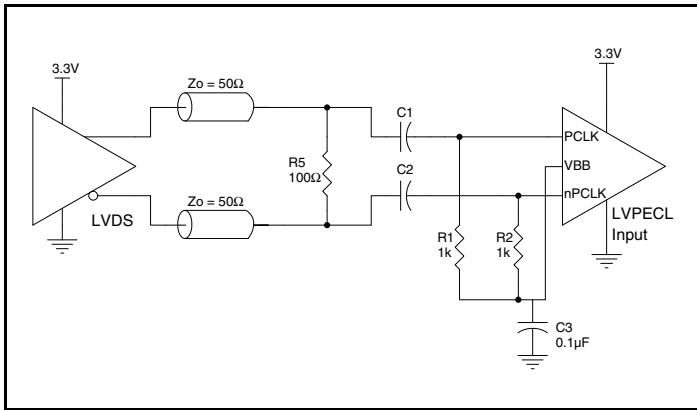

Figure 2C. PCLK/nPCLK Input Driven by a 3.3V LVDS Driver

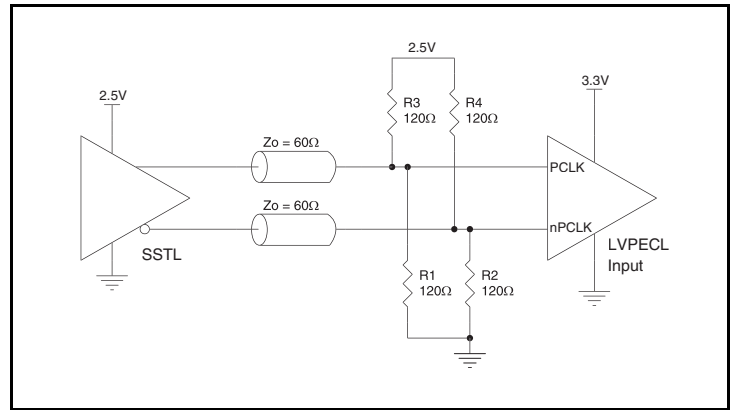

Figure 2D. PCLK/nPCLK Input Driven by a 3.3V SSTL Driver

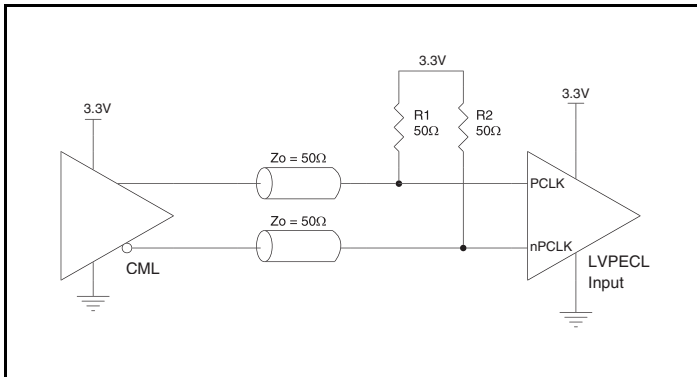

Figure 2E. PCLK/nPCLK Input Driven by a CML Driver

Overdriving the XTAL Interface

The XTAL_IN input can accept a single-ended LVCMOS signal through an AC coupling capacitor. A general interface diagram is shown in *Figure 3A*. The XTAL_OUT pin can be left floating. The maximum amplitude of the input signal should not exceed 2V and the input edge rate can be as slow as 10ns. This configuration requires that the output impedance of the driver (R_o) plus the series resistance (R_s) equals the transmission line impedance. In addition,

matched termination at the crystal input will attenuate the signal in half. This can be done in one of two ways. First, R_1 and R_2 in parallel should equal the transmission line impedance. For most 50Ω applications, R_1 and R_2 can be 100Ω. This can also be accomplished by removing R_1 and making R_2 50Ω. By overdriving the crystal oscillator, the device will be functional, but note, the device performance is guaranteed by using a quartz crystal.

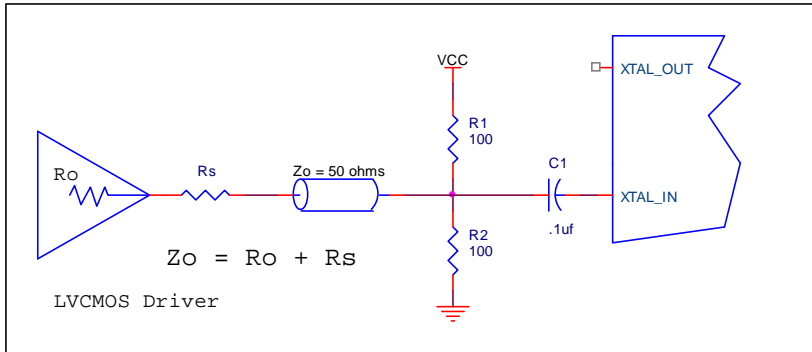

Figure 3A. General Diagram for LVCMOS Driver to XTAL Input Interface

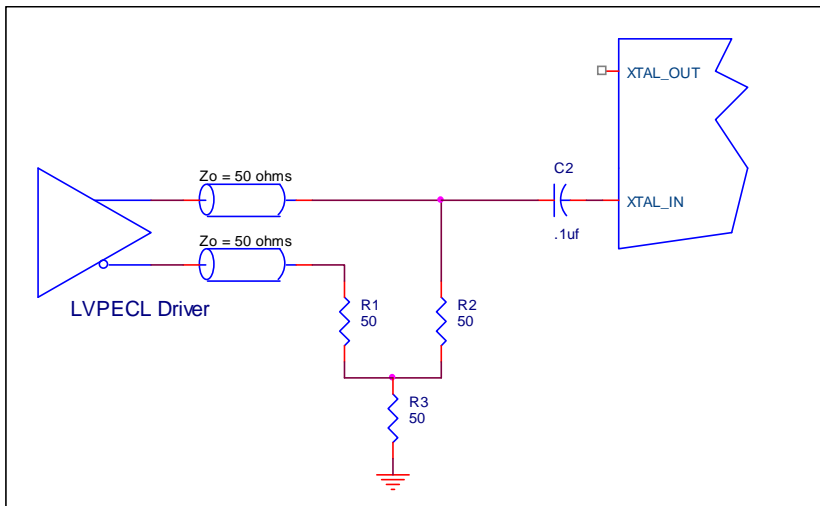

Figure 3B. General Diagram for LVPECL Driver to XTAL Input Interface

Termination for 3.3V LVPECL Outputs

The clock layout topology shown below is a typical termination for LVPECL outputs. The two different layouts mentioned are recommended only as guidelines.

The differential output pair is low impedance follower outputs that generate ECL/LVPECL compatible outputs. Therefore, terminating resistors (DC current path to ground) or current sources must be used for functionality. These outputs are designed to drive 50Ω

transmission lines. Matched impedance techniques should be used to maximize operating frequency and minimize signal distortion.

Figures 4A and 4B show two different layouts which are recommended only as guidelines. Other suitable clock layouts may exist and it would be recommended that the board designers simulate to guarantee compatibility across all printed circuit and clock component process variations.

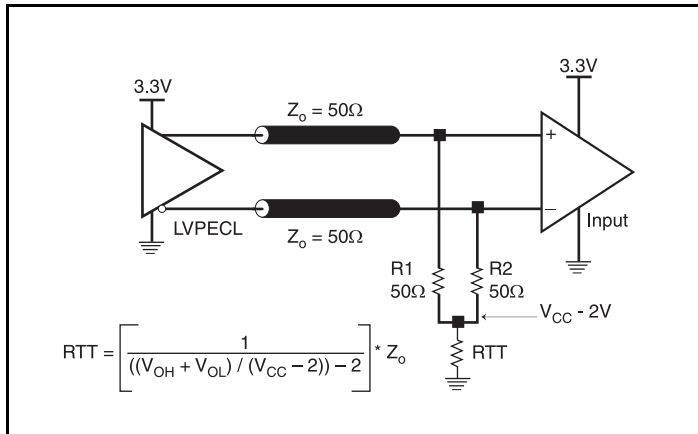

Figure 4A. 3.3V LVPECL Output Termination

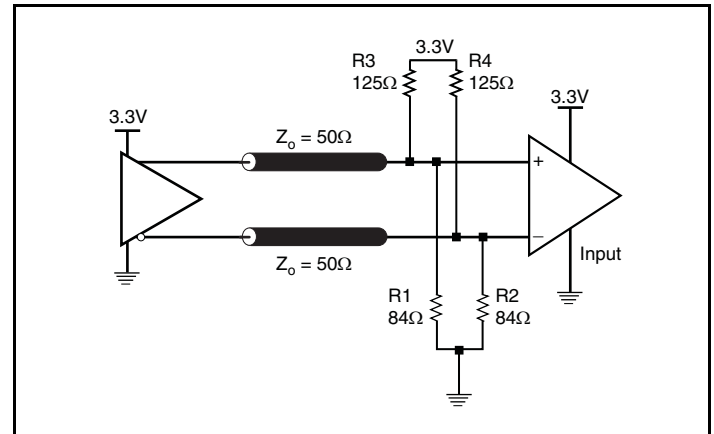

Figure 4B. 3.3V LVPECL Output Termination

LVDS Driver Termination

A general LVDS interface is shown in Figure 5. Standard termination for LVDS type output structure requires both a 100Ω parallel resistor at the receiver and a 100Ω differential transmission line environment. In order to avoid any transmission line reflection issues, the 100Ω resistor must be placed as close to the receiver as possible. IDT offers a full line of LVDS compliant devices with two types of output structures: current source and voltage source. The standard

termination schematic as shown in Figure 5 can be used with either type of output structure. If using a non-standard termination, it is recommended to contact IDT and confirm if the output is a current source or a voltage source type structure. In addition, since these outputs are LVDS compatible, the amplitude and common mode input range of the input receivers should be verified for compatibility with the output.

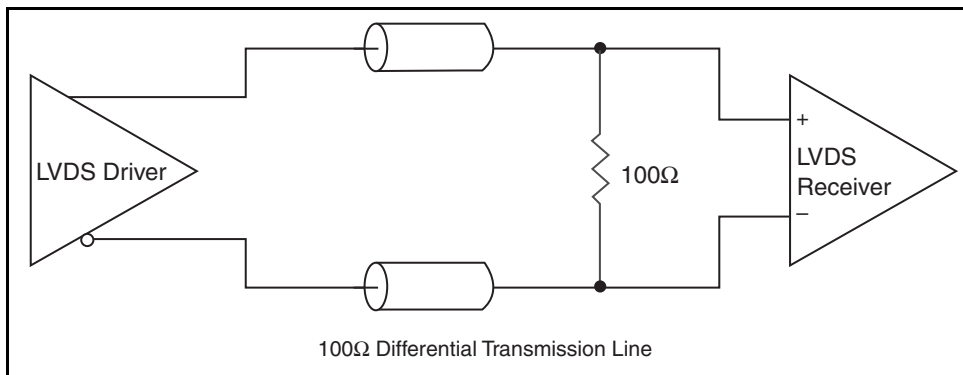

Figure 5. Typical LVDS Driver Termination

EPAD Thermal Release Path

In order to maximize both the removal of heat from the package and the electrical performance, a land pattern must be incorporated on the Printed Circuit Board (PCB) within the footprint of the package corresponding to the exposed metal pad or exposed heat slug on the package, as shown in *Figure 6*. The solderable area on the PCB, as defined by the solder mask, should be at least the same size/shape as the exposed pad/slug area on the package to maximize the thermal/electrical performance. Sufficient clearance should be designed on the PCB between the outer edges of the land pattern and the inner edges of pad pattern for the leads to avoid any shorts.

While the land pattern on the PCB provides a means of heat transfer and electrical grounding from the package to the board through a solder joint, thermal vias are necessary to effectively conduct from the surface of the PCB to the ground plane(s). The land pattern must be connected to ground through these vias. The vias act as "heat pipes". The number of vias (i.e. "heat pipes") are application specific

and dependent upon the package power dissipation as well as electrical conductivity requirements. Thus, thermal and electrical analysis and/or testing are recommended to determine the minimum number needed. Maximum thermal and electrical performance is achieved when an array of vias is incorporated in the land pattern. It is recommended to use as many vias connected to ground as possible. It is also recommended that the via diameter should be 12 to 13mils (0.30 to 0.33mm) with 1oz copper via barrel plating. This is desirable to avoid any solder wicking inside the via during the soldering process which may result in voids in solder between the exposed pad/slug and the thermal land. Precautions should be taken to eliminate any solder voids between the exposed heat slug and the land pattern. Note: These recommendations are to be used as a guideline only. For further information, please refer to the Application Note on the Surface Mount Assembly of Amkor's Thermally/Electrically Enhance Leadframe Base Package, Amkor Technology.

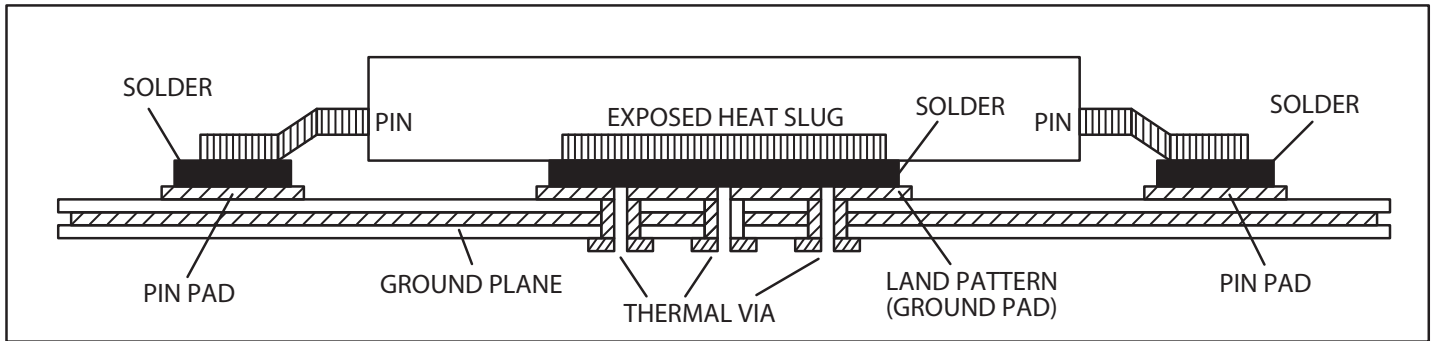

Figure 6. P.C. Assembly for Exposed Pad Thermal Release Path – Side View (drawing not to scale)

Application Schematic

Figure 7 shows an example of 8430S10I-03 application schematic. In this example, the device is operated at $V_{DD} = V_{DDA} = V_{DDO_B} = V_{DDO_CD} = V_{DDO_E} = V_{DDO_REF} = 3.3V$. An 18pF parallel resonant 25MHz crystal is used. The load capacitance $C1 = 18pF$ and $C2 = 18pF$ are recommended for frequency accuracy. Depending on the parasitics of the printed circuit board layout, these values might require a slight adjustment to optimize the frequency accuracy. Crystals with other load capacitance specifications can be used. This will require adjusting $C1$ and $C2$. For this device, the crystal load capacitors are required for proper operation.

As with any high speed analog circuitry, the power supply pins are vulnerable to noise. To achieve optimum jitter performance, power supply isolation is required. The 8430S10I-03 provides separate power supplies to isolate from coupling into the internal PLL. In order to achieve the best possible filtering, it is recommended that the placement of the filter components be on the device side of the PCB as close to the power pins as possible. If space is limited, the 0.1uF capacitor in each power pin filter should be placed on the device side of the PCB and the other components can be placed on the opposite side.

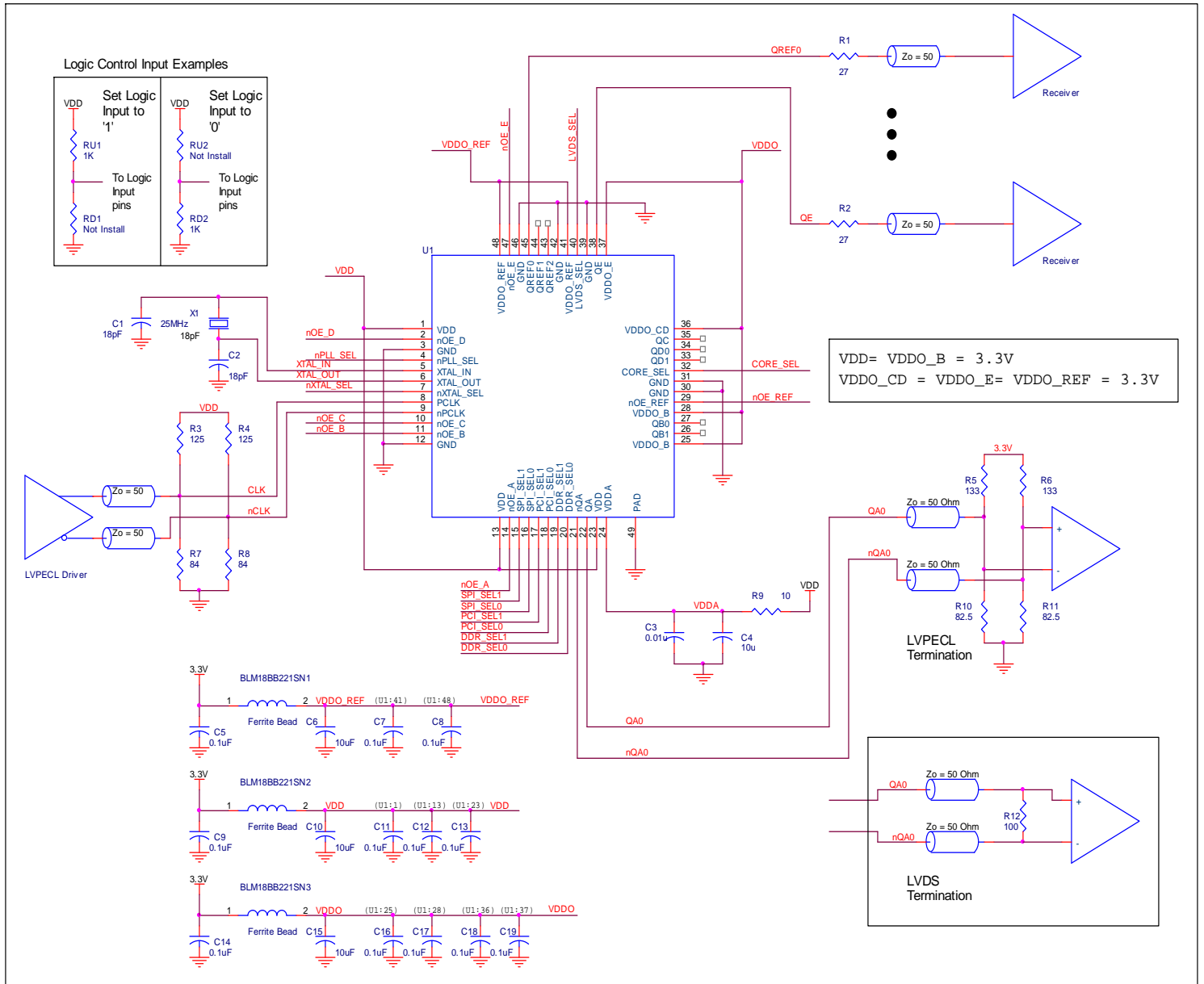

Figure 7. 8430S10I-03 Schematic Example

Power supply filter recommendations are a general guideline to be used for reducing external noise from coupling into the devices. The filter performance is designed for wide range of noise frequencies. This low-pass filter starts to attenuate noise at approximately 10kHz. If a specific frequency noise component is known, such as switching power supply frequencies, it is recommended that component values be adjusted and if required, additional filtering be added.

Additionally, good general design practices for power plane voltage stability suggests adding bulk capacitances in the local area of all devices.

The schematic example focuses on functional connections and is not configuration specific. Refer to the pin description and functional tables in the datasheet to ensure the logic control inputs are properly set.

Power Considerations (LVCMOS/LVDS Outputs)

This section provides information on power dissipation and junction temperature for the 8430S10I-03. Equations and example calculations are also provided.

1. Power Dissipation.

The total power dissipation for the 8430S10I-03 is the sum of the core power plus the power dissipated in the load(s). The following is the power dissipation for $V_{DD} = 3.3V + 5\% = 3.465V$, which gives worst case results.

Core and LVDS Output Power Dissipation

- Power (core, LVDS) = $V_{DD_MAX} * (I_{DD} + I_{DDA}) = 3.465V * (150mA + 20mA) = \mathbf{589.05mW}$

LVCMOS Output Power Dissipation

- Dynamic Power Dissipation at 133.33MHz
 $\text{Power (133.33MHz)} = C_{PD} * \text{Frequency} * (V_{DDO})^2 = 10pF * 133.33MHz * (3.465V)^2 = \mathbf{16mW \text{ per output}}$
 $\text{Total Power (133.33MHz)} = 16mW * 1 = \mathbf{16mW}$
- Power(125MHz) = $10pF * 125MHz * (3.465V)^2 = \mathbf{15mW \text{ per output}}$
 $\text{Total Power (125MHz)} = 15mW * 3 = \mathbf{45mW}$
- Dynamic Power Dissipation at 25MHz
 $\text{Power (25MHz)} = C_{PD} * \text{Frequency} * (V_{DDO})^2 = 10pF * 25MHz * (3.465V)^2 = \mathbf{3mW \text{ per output}}$
 $\text{Total Power (25MHz)} = 3mW * 3 = \mathbf{9mW}$
- Power (50MHz) = $C_{PD} * \text{Frequency} * (V_{DDO})^2 = 10pF * 50MHz * (3.465V)^2 = \mathbf{6mW \text{ per output}}$
 $\text{Total Power (50MHz)} = 6mW * 2 = \mathbf{12mW}$

Total Power Dissipation

- Total Power**
 $= \text{Power (core, LVDS)} + \text{Total Power (133.33MHz)} + \text{Total Power (125MHz)} + \text{Total Power (25MHz)} + \text{Total Power (50MHz)}$
 $= 589.05mW + 16mW + 45mW + 9mW + 12mW$
 $= \mathbf{671.05mW}$

2. Junction Temperature.

Junction temperature, T_j , is the temperature at the junction of the bond wire and bond pad directly affects the reliability of the device. The maximum recommended junction temperature is 125°C. Limiting the internal transistor junction temperature, T_j , to 125°C ensures that the bond wire and bond pad temperature remains below 125°C.

The equation for T_j is as follows: $T_j = \theta_{JA} * Pd_total + T_A$

T_j = Junction Temperature

θ_{JA} = Junction-to-Ambient Thermal Resistance

Pd_total = Total Device Power Dissipation (example calculation is in section 1 above)

T_A = Ambient Temperature

In order to calculate junction temperature, the appropriate junction-to-ambient thermal resistance θ_{JA} must be used. Assuming no air flow and a multi-layer board, the appropriate value is 33.1°C/W per Table 7A below.

Therefore, T_j for an ambient temperature of 85°C with all outputs switching is:

$$85^\circ\text{C} + 0.671\text{W} * 33.1^\circ\text{C/W} = 107.2^\circ\text{C}. \text{ This is below the limit of } 125^\circ\text{C}.$$

This calculation is only an example. T_j will obviously vary depending on the number of loaded outputs, supply voltage, air flow and the type of board.

Table 7A. Thermal Resistance θ_{JA} for 48 Lead TQFP, EPAD Forced Convection

θ_{JA} Vs. Air Flow			
Meters per Second	0	1	2.5
Multi-Layer PCB, JEDEC Standard Test Boards	33.1°C/W	27.2°C/W	25.7°C/W

Power Considerations (LVCMOS/LVPECL Outputs)

This section provides information on power dissipation and junction temperature for the 8430S10I-03. Equations and example calculations are also provided.

1. Power Dissipation.

The total power dissipation for the 8430S10I-03 is the sum of the core power plus the analog power plus the power dissipated in the load(s). The following is the power dissipation for $V_{DD} = 3.3V + 5\% = 3.465V$, which gives worst case results.

Core and LVPECL Output Power Dissipation

- Power (core)_{MAX} = $V_{DD_MAX} * I_{EE_MAX} = 3.465V * 186mA = \mathbf{644.49mW}$
- Power (output)_{MAX} = **30mW/Loaded Output Pair**

LVCMOS Output Power Dissipation

- Dynamic Power Dissipation at 133.33MHz
 $\text{Power (133.33MHz)} = C_{PD} * \text{Frequency} * (V_{DDO})^2 = 10pF * 133.33MHz * (3.465V)^2 = \mathbf{16mW \text{ per output}}$
Total Power (133.33MHz) = 16mW * 1 = 16mW
- $\text{Power(125MHz)} = 10pF * 125MHz * (3.465V)^2 = \mathbf{15mW \text{ per output}}$
Total Power (125MHz) = 15mW * 3 = 45mW
- Dynamic Power Dissipation at 25MHz
 $\text{Power (25MHz)} = C_{PD} * \text{Frequency} * (V_{DDO})^2 = 10pF * 25MHz * (3.465V)^2 = \mathbf{3mW \text{ per output}}$
Total Power (25MHz) = 3mW * 3 = 9mW
- $\text{Power (50MHz)} = C_{PD} * \text{Frequency} * (V_{DDO})^2 = 10pF * 50MHz * (3.465V)^2 = \mathbf{6mW \text{ per output}}$
Total Power (50MHz) = 6mW * 2 = 12mW

Total Power Dissipation

- **Total Power**
 = Power (core, LVPECL) + Total Power (133.33MHz) + Total Power (125MHz) + Total Power (25MHz) + Total Power (50MHz)
 = 644.49mW + 16mW + 45mW + 9mW + 12mW
 = **726.49mW**

2. Junction Temperature.

Junction temperature, T_j , is the temperature at the junction of the bond wire and bond pad directly affects the reliability of the device. The maximum recommended junction temperature is 125°C. Limiting the internal transistor junction temperature, T_j , to 125°C ensures that the bond wire and bond pad temperature remains below 125°C.

The equation for T_j is as follows: $T_j = \theta_{JA} * Pd_total + T_A$

T_j = Junction Temperature

θ_{JA} = Junction-to-Ambient Thermal Resistance

Pd_total = Total Device Power Dissipation (example calculation is in section 1 above)

T_A = Ambient Temperature

In order to calculate junction temperature, the appropriate junction-to-ambient thermal resistance θ_{JA} must be used. Assuming no air flow and a multi-layer board, the appropriate value is 33.1°C/W per Table 7B below.

Therefore, T_j for an ambient temperature of 85°C with all outputs switching is:

$$85^\circ\text{C} + 0.727\text{W} * 33.1^\circ\text{C/W} = 109.1^\circ\text{C}. \text{ This is below the limit of } 125^\circ\text{C}.$$

This calculation is only an example. T_j will obviously vary depending on the number of loaded outputs, supply voltage, air flow and the type of board.

Table 7B. Thermal Resistance θ_{JA} for 48 Lead TQFP, EPAD Forced Convection

θ_{JA} Vs. Air Flow			
Meters per Second	0	1	2.5
Multi-Layer PCB, JEDEC Standard Test Boards	33.1°C/W	27.2°C/W	25.7°C/W

3. Calculations and Equations.

The purpose of this section is to calculate the power dissipation for the LVPECL output pairs.

The LVPECL output driver circuit and termination are shown in *Figure 8*.

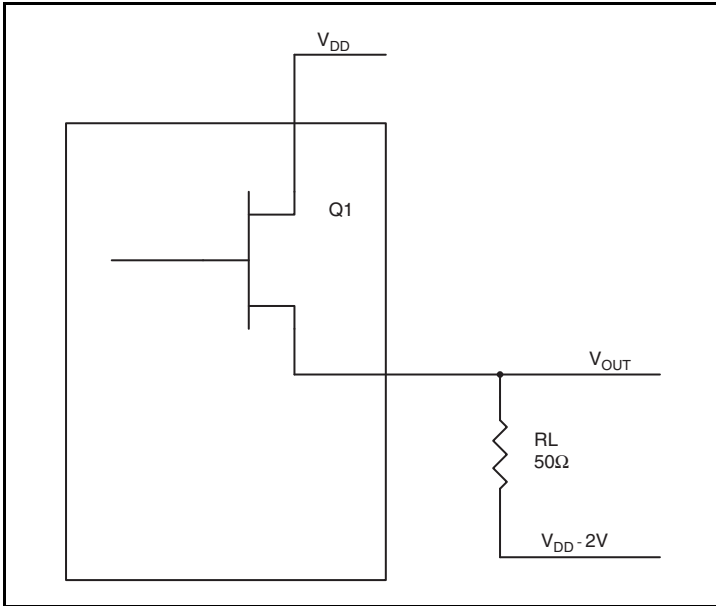

Figure 8. LVPECL Driver Circuit and Termination

To calculate worst case power dissipation into the load, use the following equations which assume a 50Ω load, and a termination voltage of $V_{DD} - 2V$.

- For logic high, $V_{OUT} = V_{OH_MAX} = V_{DD_MAX} - 0.9V$
 $(V_{DD_MAX} - V_{OH_MAX}) = 0.9V$
- For logic low, $V_{OUT} = V_{OL_MAX} = V_{DD_MAX} - 1.7V$
 $(V_{DD_MAX} - V_{OL_MAX}) = 1.7V$

Pd_H is power dissipation when the output drives high.

Pd_L is the power dissipation when the output drives low.

$$Pd_H = [(V_{OH_MAX} - (V_{DD_MAX} - 2V))/R_L] * (V_{DD_MAX} - V_{OH_MAX}) = [(2V - (V_{DD_MAX} - V_{OH_MAX}))/R_L] * (V_{DD_MAX} - V_{OH_MAX}) = [(2V - 0.9V)/50\Omega] * 0.9V = \mathbf{19.8mW}$$

$$Pd_L = [(V_{OL_MAX} - (V_{DD_MAX} - 2V))/R_L] * (V_{DD_MAX} - V_{OL_MAX}) = [(2V - (V_{DD_MAX} - V_{OL_MAX}))/R_L] * (V_{DD_MAX} - V_{OL_MAX}) = [(2V - 1.7V)/50\Omega] * 1.7V = \mathbf{10.2mW}$$

Total Power Dissipation per output pair = $Pd_H + Pd_L = \mathbf{30mW}$

Reliability Information

Table 8. θ_{JA} vs. Air Flow Table for a 48 Lead TQFP, EPAD

θ_{JA} vs. Air Flow			
Meters per Second	0	1	2.5
Multi-Layer PCB, JEDEC Standard Test Boards	33.1°C/W	27.2°C/W	25.7°C/W

Transistor Count

The transistor count for 8430S10I-03 is: 9,291

Package Outline and Package Dimensions

Package Outline - Y Suffix for 48 Lead TQFP, EPAD

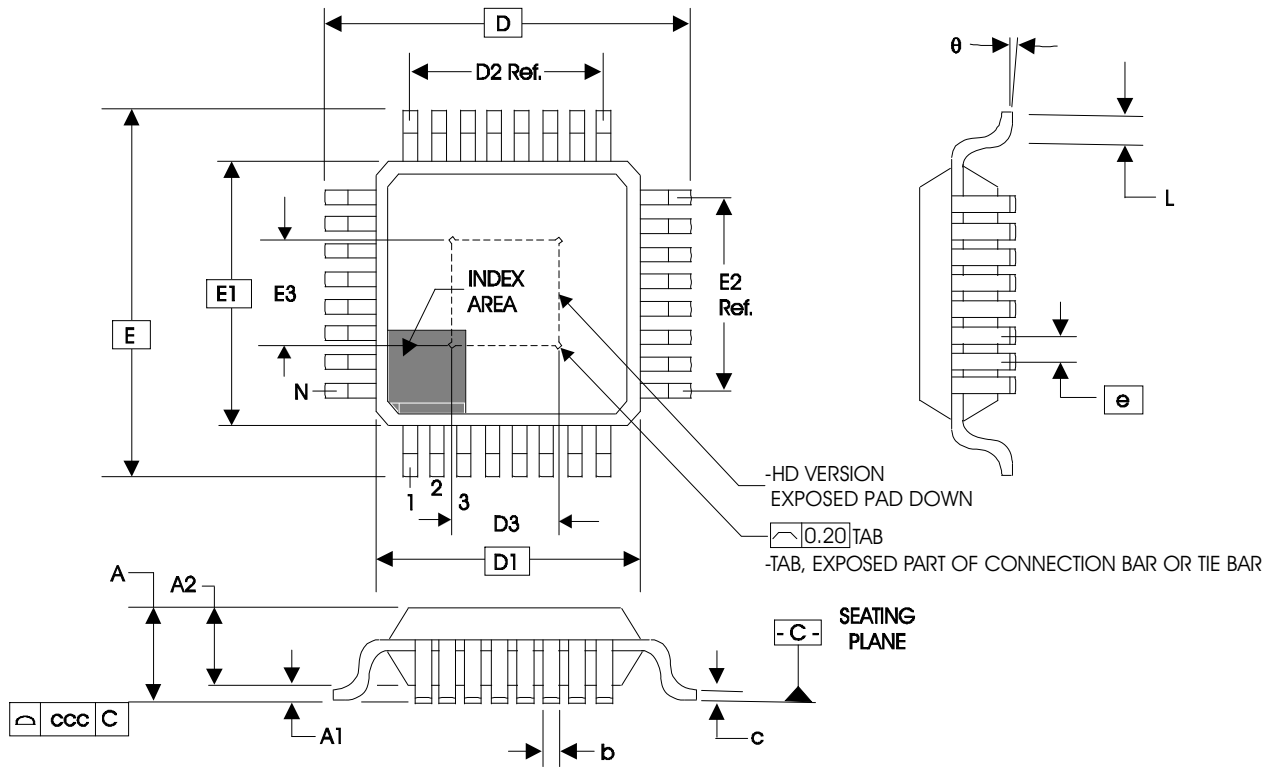

Table 9. Package Dimensions 48L TQFP, EPAD

JEDEC Variation: ABC - HD			
All Dimensions in Millimeters			
Symbol	Minimum	Nominal	Maximum
N		48	
A			1.20
A1	0.05	0.10	0.15
A2	0.95	1.00	1.05
b	0.17	0.22	0.27
c	0.09		0.20
D & E		9.00 Basic	
D1 & E1		7.00 Basic	
D2 & E2		5.50 Ref.	
D3 & E3		3.5	
e		0.5 Basic	
L	0.45	0.60	0.75
theta	0°		7°
ccc			0.08

Reference Document: JEDEC Publication 95, MS-026

Ordering Information

Table 10. Ordering Information

Part/Order Number	Marking	Package	Shipping Packaging	Temperature
8430S10BYI-03LF	ICS0S10BI03L	"Lead-Free" 48 TQFP, EPAD	Tray	-40°C to 85°C
8430S10BYI-03LFT	ICS0S10BI03L	"Lead-Free" 48 TQFP, EPAD	Tape & Reel	-40°C to 85°C

Revision History Sheet

Rev	Table	Page	Description of Change	Date
A	T6	9 14	AC Characteristics Table - deleted Cycle-to-Cycle Jitter specs Per PCN #532. Parameter Measurement Information, deleted Cycle-to-Cycle Jitter diagrams.	2/22/11
A	T10	29	Ordering Information - Removed quantity from tape and reel. Deleted LF note below table. Removed ICS where needed. Updated header and footer.	10/5/16

IMPORTANT NOTICE AND DISCLAIMER

RENESAS ELECTRONICS CORPORATION AND ITS SUBSIDIARIES (“RENESAS”) PROVIDES TECHNICAL SPECIFICATIONS AND RELIABILITY DATA (INCLUDING DATASHEETS), DESIGN RESOURCES (INCLUDING REFERENCE DESIGNS), APPLICATION OR OTHER DESIGN ADVICE, WEB TOOLS, SAFETY INFORMATION, AND OTHER RESOURCES “AS IS” AND WITH ALL FAULTS, AND DISCLAIMS ALL WARRANTIES, EXPRESS OR IMPLIED, INCLUDING, WITHOUT LIMITATION, ANY IMPLIED WARRANTIES OF MERCHANTABILITY, FITNESS FOR A PARTICULAR PURPOSE, OR NON-INFRINGEMENT OF THIRD-PARTY INTELLECTUAL PROPERTY RIGHTS.

These resources are intended for developers who are designing with Renesas products. You are solely responsible for (1) selecting the appropriate products for your application, (2) designing, validating, and testing your application, and (3) ensuring your application meets applicable standards, and any other safety, security, or other requirements. These resources are subject to change without notice. Renesas grants you permission to use these resources only to develop an application that uses Renesas products. Other reproduction or use of these resources is strictly prohibited. No license is granted to any other Renesas intellectual property or to any third-party intellectual property. Renesas disclaims responsibility for, and you will fully indemnify Renesas and its representatives against, any claims, damages, costs, losses, or liabilities arising from your use of these resources. Renesas' products are provided only subject to Renesas' Terms and Conditions of Sale or other applicable terms agreed to in writing. No use of any Renesas resources expands or otherwise alters any applicable warranties or warranty disclaimers for these products.

(Disclaimer Rev.1.01 Jan 2024)

Corporate Headquarters

TOYOSU FORESIA, 3-2-24 Toyosu,
Koto-ku, Tokyo 135-0061, Japan
www.renesas.com

Trademarks



Renesas and the Renesas logo are trademarks of Renesas Electronics Corporation. All trademarks and registered trademarks are the property of their respective owners.

Contact Information

For further information on a product, technology, the most up-to-date version of a document, or your nearest sales office, please visit www.renesas.com/contact-us/.

Looking for pricing, stock, or lifecycle information?

Click below to explore more details on WIN SOURCE:

-  [View 8430S10BYI-03LFT on WIN SOURCE](#)
-  [Renesas Electronics America](#) Information

Optimize Your Supply Chain with WIN SOURCE Solutions

-  Global Sourcing Solution
-  Obsolete Management
-  Cost Control Management
-  Shortage Management
-  Alternative Solution
-  Excess Inventory Management