



**THE DATASHEET OF**  
**843002AG-01LF**



**GENERAL DESCRIPTION**

The 843002-01 is a 2 output LVPECL synthesizer optimized to generate Ethernet reference clock frequencies. Using a 25MHz 18pF parallel resonant crystal, the following frequencies can be generated based on the 2 frequency select pins (F\_SEL[1:0]): 156.25MHz, 125MHz, and 62.5MHz. The 843002-01 uses ICS' 3<sup>rd</sup> generation low phase noise VCO technology and can achieve 1ps or lower typical rms phase jitter, easily meeting Ethernet jitter requirements. The 843002-01 is packaged in a small 20-pin TSSOP package.

**FEATURES**

- Two 3.3V LVPECL outputs
  - Selectable crystal oscillator interface or LVCMOS single-ended input
  - Supports the following input frequencies: 156.25MHz, 125MHz and 62.5MHz
  - VCO range: 560MHz - 680MHz
  - RMS phase jitter @ 156.25MHz, using a 25MHz crystal (1.875MHz-20MHz): 0.54ps (typical)
  - Typical phase noise at 156.25MHz
- Phase noise:
- | Offset | Noise Power   |
|--------|---------------|
| 100Hz  | -97.3 dBc/Hz  |
| 1KHz   | -119.1 dBc/Hz |
| 10KHz  | -126.4 dBc/Hz |
| 100KHz | -127.6 dBc/Hz |
- Full 3.3V supply mode
  - Lead-Free package fully RoHS compliant
  - -30°C to 85°C ambient operating temperature

FREQUENCY SELECT FUNCTION TABLE

Inputs				Output Frequency (25MHz Ref.)
F_SEL1	F_SEL0	M Divider Value	N Divider Value	
0	0	25	4	156.25
0	1	25	5	125
1	0	25	10	62.5
1	1	Not Used		Not Used

**PIN ASSIGNMENT**

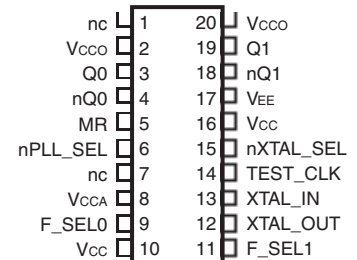

**BLOCK DIAGRAM**

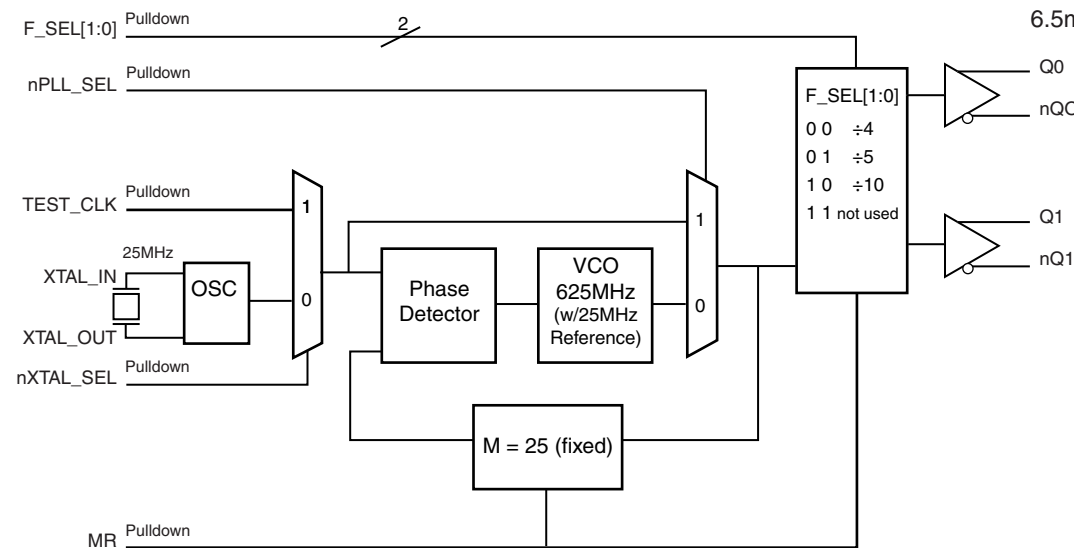

**843002-01  
20-Lead TSSOP**

6.5mm x 4.4mm x 0.92mm  
package body  
**G Package**  
Top View

**TABLE 1. PIN DESCRIPTIONS**

Number	Name	Type		Description
1, 7	nc	Unused		No connect.
2, 20	V <sub>CCO</sub>	Power		Output supply pins.
3, 4	Q0, nQ0	Output		Differential output pair. LVPECL interface levels.
5	MR	Input	Pulldown	Active HIGH Master Reset. When logic HIGH, the internal dividers are reset causing the true outputs Qx to go low and the inverted outputs nQx to go high. When logic LOW, the internal dividers and the outputs are enabled. LVCMOS/LVTTL interface levels.
6	nPLL_SEL	Input	Pulldown	Selects between the PLL and TEST_CLK as input to the dividers. When LOW, selects PLL (PLL Enable). When HIGH, deselects the reference clock (PLL Bypass). LVCMOS/LVTTL interface levels.
8	V <sub>CCA</sub>	Power		Analog supply pin.
9, 11	F_SEL0, F_SEL1	Input	Pulldown	Frequency select pins. LVCMOS/LVTTL interface levels.
10, 16	V <sub>CC</sub>	Power		Core supply pin.
12, 13	XTAL_OUT, XTAL_IN	Input		Parallel resonant crystal interface. XTAL_OUT is the output, XTAL_IN is the input.
14	TEST_CLK	Input	Pulldown	LVCMOS/LVTTL clock input.
15	nXTAL_SEL	Input	Pulldown	Selects between crystal or TEST_CLK inputs as the the PLL Reference source. Selects XTAL inputs when LOW. Selects TEST_CLK when HIGH. LVCMOS/LVTTL interface levels.
17	V <sub>EE</sub>	Power		Negative supply pins.
18, 19	nQ1, Q1	Output		Differential output pair. LVPECL interface levels.
2, 20	V <sub>CCO</sub>	Power		Output supply pins.

NOTE: refer to internal input resistors. See Table 2, Pin Characteristics, for typical values.

**TABLE 2. PIN CHARACTERISTICS**

Symbol	Parameter	Test Conditions	Minimum	Typical	Maximum	Units
C <sub>IN</sub>	Input Capacitance			4		pF
R <sub>PULLDOWN</sub>	Input Pulldown Resistor			51		kΩ

### ABSOLUTE MAXIMUM RATINGS

Supply Voltage, $V_{CC}$	4.6V
Inputs, $V_I$	-0.5V to $V_{CC} + 0.5V$
Outputs, $I_O$	
Continuous Current	50mA
Surge Current	100mA
Package Thermal Impedance, $\theta_{JA}$	73.2°C/W (0 lfpm)
Storage Temperature, $T_{STG}$	-65°C to 150°C

NOTE: Stresses beyond those listed under Absolute Maximum Ratings may cause permanent damage to the device. These ratings are stress specifications only. Functional operation of product at these conditions or any conditions beyond those listed in the *DC Characteristics* or *AC Characteristics* is not implied. Exposure to absolute maximum rating conditions for extended periods may affect product reliability.

**TABLE 3A. POWER SUPPLY DC CHARACTERISTICS,  $V_{CC} = V_{CCA} = V_{CCO} = 3.3V \pm 10\%$ ,  $T_A = -30^\circ C$  TO  $85^\circ C$**

Symbol	Parameter	Test Conditions	Minimum	Typical	Maximum	Units
$V_{CC}$	Core Supply Voltage		2.97	3.3	3.63	V
$V_{CCA}$	Analog Supply Voltage		2.97	3.3	3.63	V
$V_{CCO}$	Output Supply Voltage		2.97	3.3	3.63	V
$I_{EE}$	Power Supply Current				135	mA
$I_{CC}$	Core Supply Current				100	mA
$I_{CCA}$	Analog Supply Current				15	mA
$I_{CCO}$	Output Supply Current				31	mA

**TABLE 3B. LVCMOS / LVTTTL DC CHARACTERISTICS,  $V_{CC} = V_{CCA} = V_{CCO} = 3.3V \pm 10\%$ ,  $T_A = -30^\circ C$  TO  $85^\circ C$**

Symbol	Parameter	Test Conditions	Minimum	Typical	Maximum	Units
$V_{IH}$	Input High Voltage		2		$V + 0.3$	V
$V_{IL}$	Input Low Voltage	nPLL_SEL, nXTAL_SEL, F_SEL0, F_SEL1, MR	-0.3		0.8	V
		TEST_CLK	-0.3		1.0	V
$I_{IH}$	Input High Current	TEST_CLK, MR, nPLL_SEL, nXTAL_SEL	$V_{CC} = V_{IN} = 3.63V$		150	$\mu A$
$I_{IL}$	Input Low Current	TEST_CLK, MR, nPLL_SEL, nXTAL_SEL	$V_{CC} = 3.63V, V_{IN} = 0V$		-5	$\mu A$

**TABLE 3C. LVPECL DC CHARACTERISTICS,  $V_{CC} = V_{CCA} = V_{CCO} = 3.3V \pm 10\%$ ,  $T_A = -30^\circ C$  TO  $85^\circ C$**

Symbol	Parameter	Test Conditions	Minimum	Typical	Maximum	Units
$V_{OH}$	Output High Voltage; NOTE 1		$V_{CCO} - 1.4$		$V_{CCO} - 0.9$	V
$V_{OL}$	Output Low Voltage; NOTE 1		$V_{CCO} - 2.0$		$V_{CCO} - 1.7$	V
$V_{SWING}$	Peak-to-Peak Output Voltage Swing		0.6		1.0	V

NOTE 1: Outputs terminated with 50 to  $V_{CCO} - 2V$ .

**TABLE 4. CRYSTAL CHARACTERISTICS**

Parameter	Test Conditions	Minimum	Typical	Maximum	Units
Mode of Oscillation		Fundamental			
Frequency		22.4	25	27.2	MHz
Equivalent Series Resistance (ESR)				50	$\Omega$
Shunt Capacitance				7	pF

NOTE: Characterized using an 18pF parallel resonant crystal.

**TABLE 5. AC CHARACTERISTICS,  $V_{CC} = V_{CCA} = V_{CCO} = 3.3V \pm 10\%$ ,  $T_A = -30^\circ\text{C}$  TO  $85^\circ\text{C}$** 

Symbol	Parameter	Test Conditions	Minimum	Typical	Maximum	Units
$f_{OUT}$	Output Frequency	F_SEL[1,:0] = 00	140		170	MHz
		F_SEL[1,:0] = 01	112		136	MHz
		F_SEL[1,:0] = 10	56		68	MHz
tsk(o)	Output Skew; NOTE 1, 2			20	ps	
tjit( $\emptyset$ )	RMS Phase Jitter; NOTE 3	156.25MHz, (1.875MHz - 20MHz)		0.54		ps
		125MHz, (1.875MHz - 20MHz)		0.60		ps
		62.5MHz, (1.875MHz - 20MHz)		0.79		ps
$t_R / t_F$	Output Rise/Fall Time	20% to 80%	300		600	ps
odc	Output Duty Cycle		49		51	%

NOTE 1: Defined as skew between outputs at the same supply voltages and with equal load conditions. Measured at  $V_{CCO}/2$ .

NOTE 2: This parameter is defined in accordance with JEDEC Standard 65.

NOTE 3: Phase jitter is dependent on the input source used.

TYPICAL PHASE NOISE AT 62.5MHz

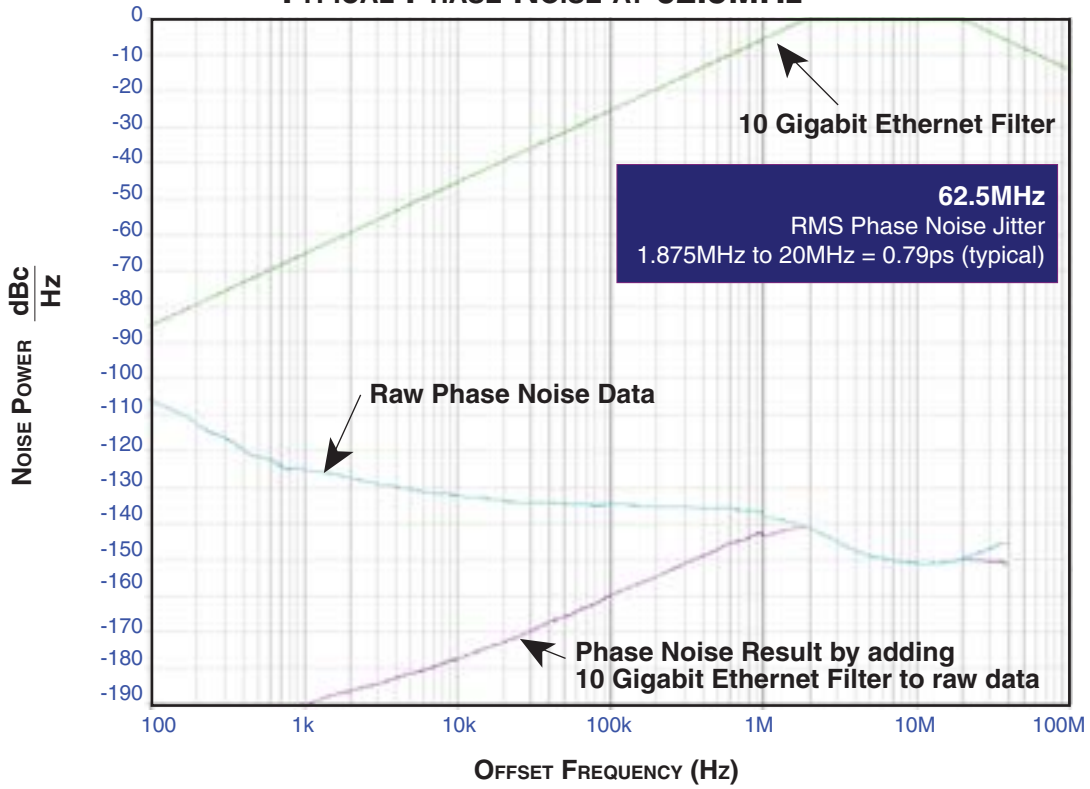

TYPICAL PHASE NOISE AT 125MHz

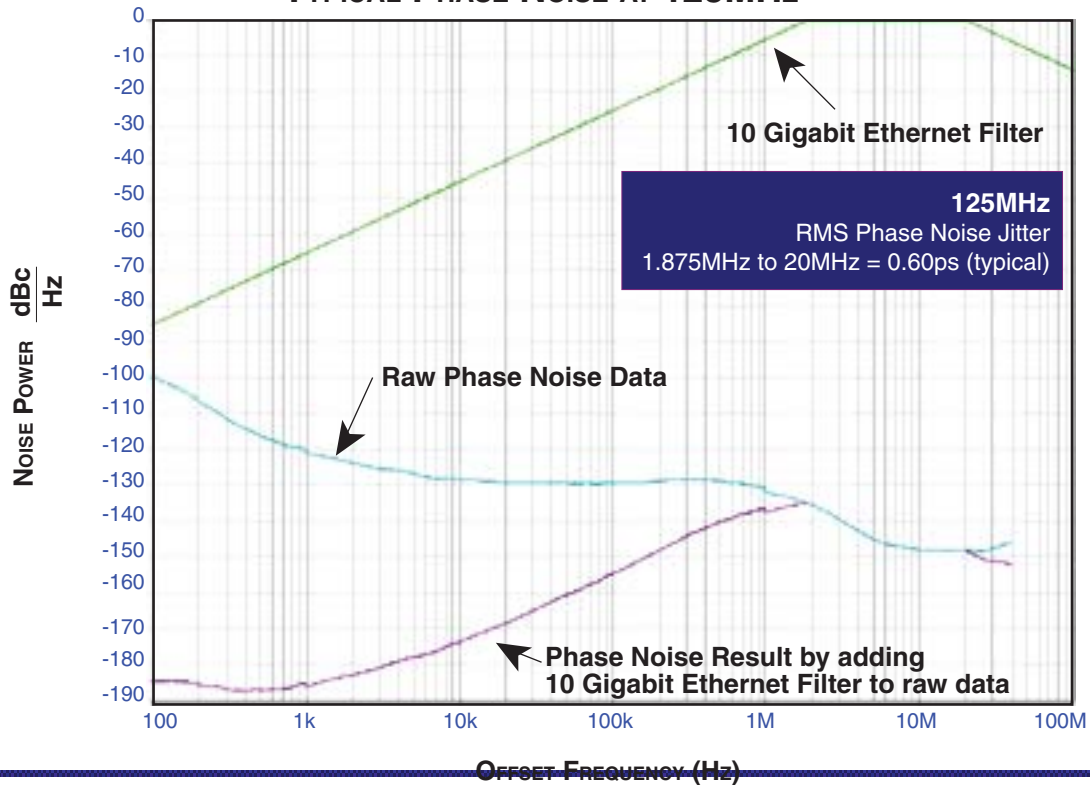

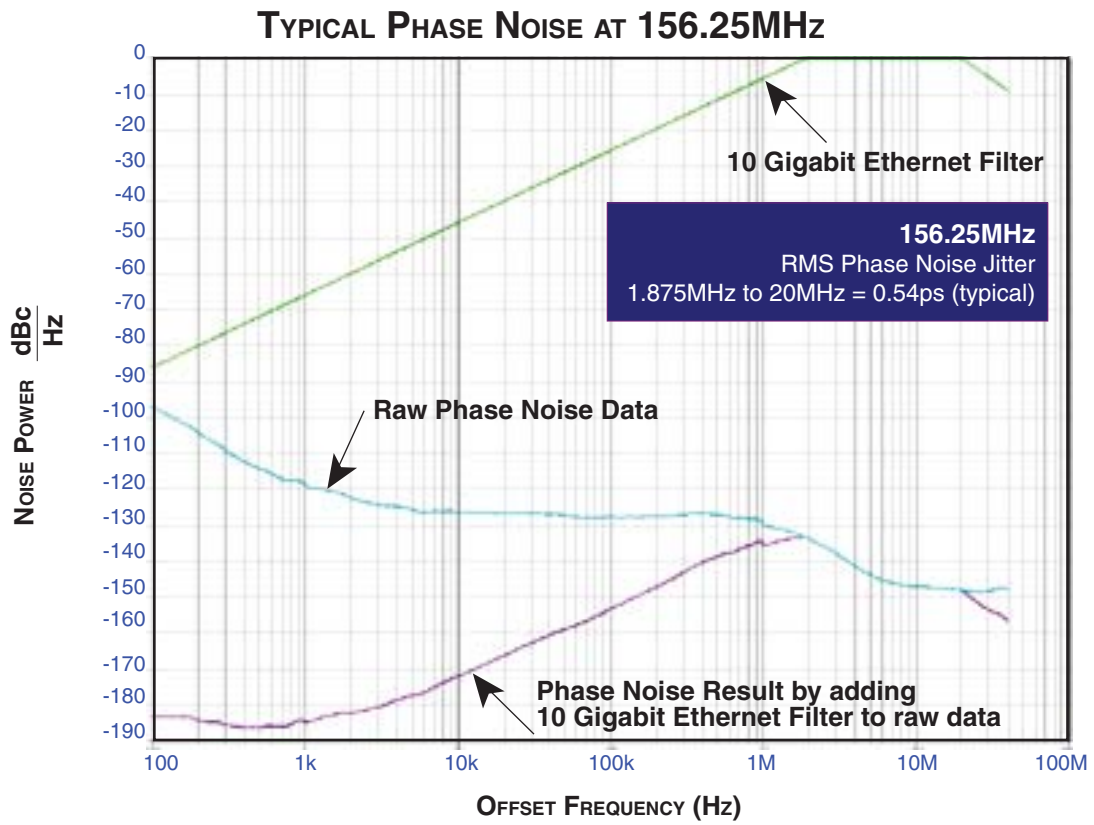

## PARAMETER MEASUREMENT INFORMATION

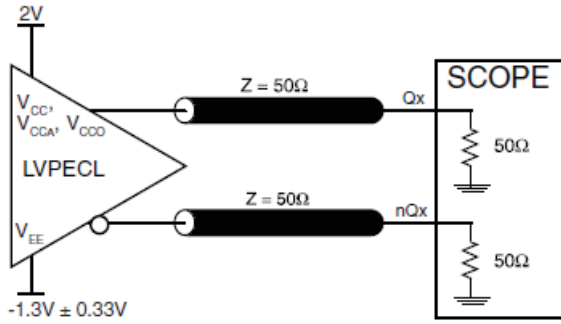

3.3V CORE/3.3V OUTPUT LOAD AC TEST CIRCUIT

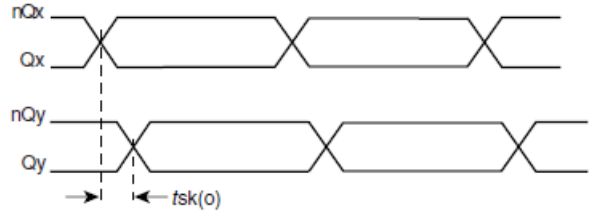

OUTPUT SKEW

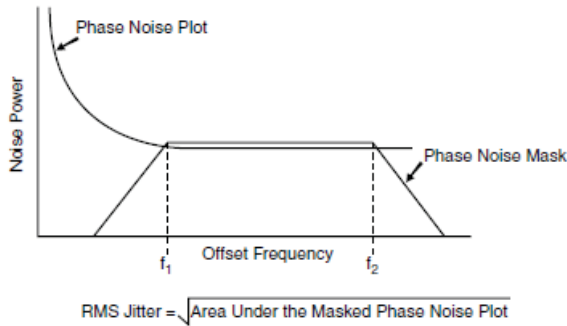

RMS PHASE JITTER

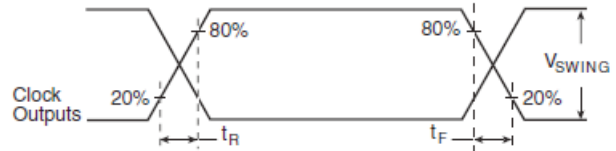

OUTPUT RISE/FALL TIME

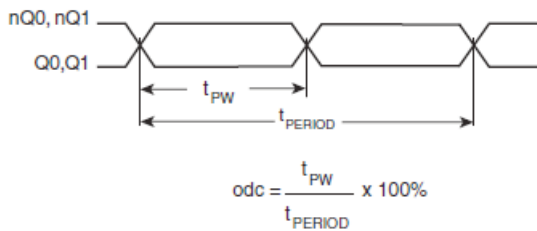

OUTPUT DUTY CYCLE/PULSE WIDTH/PERIOD

## APPLICATION INFORMATION

### POWER SUPPLY FILTERING TECHNIQUES

As in any high speed analog circuitry, the power supply pins are vulnerable to random noise. The 843002-01 provides separate power supplies to isolate any high switching noise from the outputs to the internal PLL.  $V_{CC}$ ,  $V_{CCA}$ , and  $V_{CCO}$  should be individually connected to the power supply plane through vias, and bypass capacitors should be used for each pin. To achieve optimum jitter performance, power supply isolation is required. *Figure 1* illustrates how a  $10\Omega$  resistor along with a  $10\mu\text{F}$  and a  $.01\mu\text{F}$  bypass capacitor should be connected to each  $V_{CCA}$ .

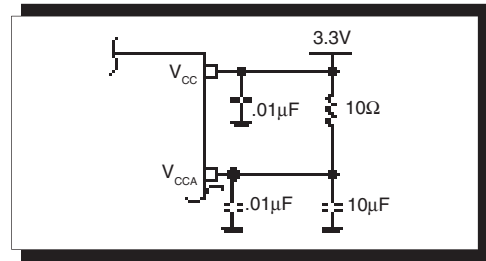

FIGURE 1. POWER SUPPLY FILTERING

### TERMINATION FOR 3.3V LVPECL OUTPUT

The clock layout topology shown below is a typical termination for LVPECL outputs. The two different layouts mentioned are recommended only as guidelines.

FOUT and nFOUT are low impedance follower outputs that generate ECL/LVPECL compatible outputs. Therefore, terminating resistors (DC current path to ground) or current sources must be used for functionality. These outputs are designed to

drive  $50\Omega$  transmission lines. Matched impedance techniques should be used to maximize operating frequency and minimize signal distortion. *Figures 2A and 2B* show two different layouts which are recommended only as guidelines. Other suitable clock layouts may exist and it would be recommended that the board designers simulate to guarantee compatibility across all printed circuit and clock component process variations.

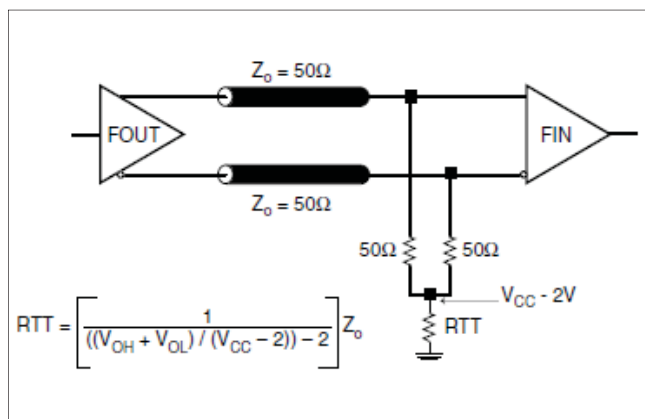

FIGURE 2A. LVPECL OUTPUT TERMINATION

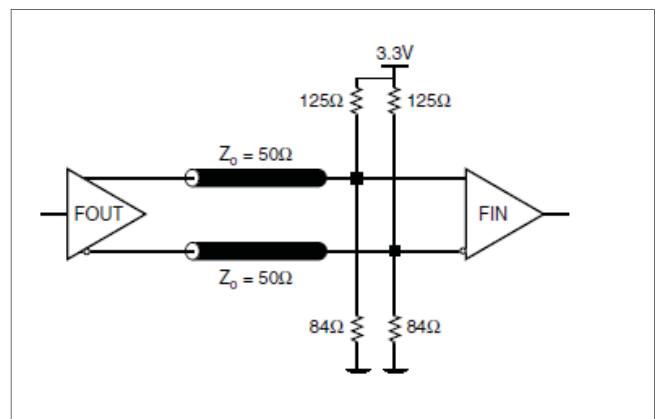

FIGURE 2B. LVPECL OUTPUT TERMINATION

**CRYSTAL INPUT INTERFACE**

The 843002-01 has been characterized with 18pF parallel resonant crystals. The capacitor values shown in *Figure 3* below were determined using a 25MHz 18pF parallel resonant crystal and were chosen to minimize the ppm error.



**LAYOUT GUIDELINE**

Figure 4A shows a schematic example of the 843002-01. An example of LVPECL termination is shown in this schematic. Additional LVPECL termination approaches are shown in the LVPECL Termination Application Note. In this example, an 18

pF parallel resonant 26.5625MHz crystal is used. The C1=27pF and C2=33pF are recommended for frequency accuracy. For different board layout, the C1 and C2 may be slightly adjusted for optimizing frequency accuracy.

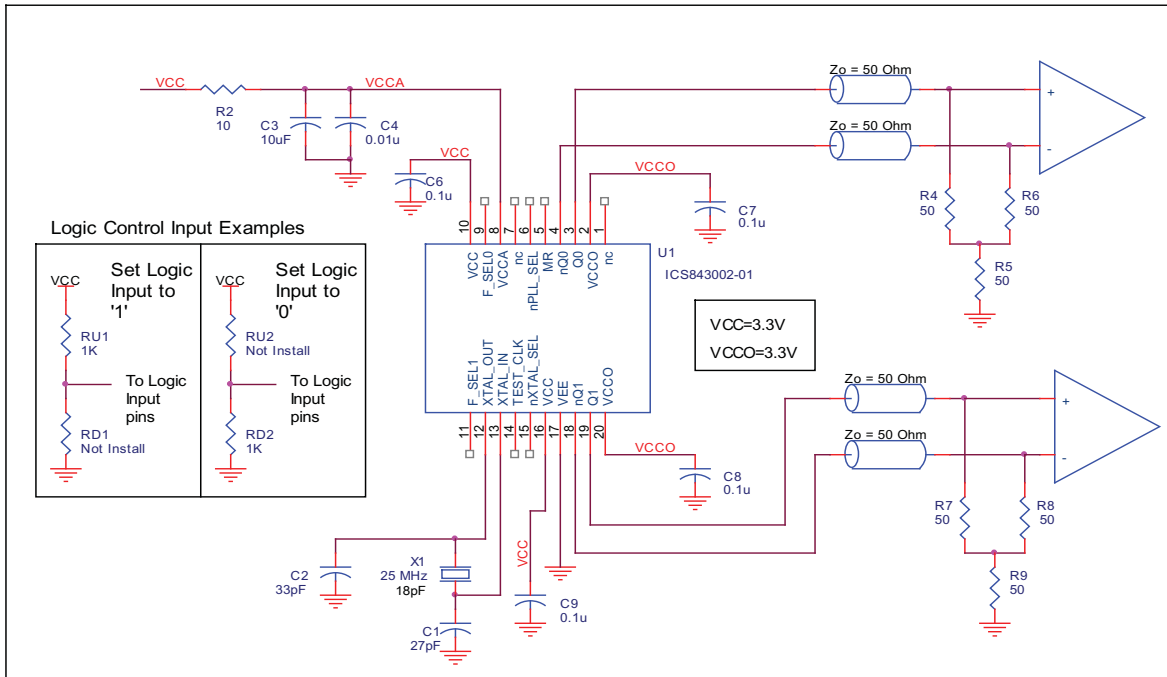
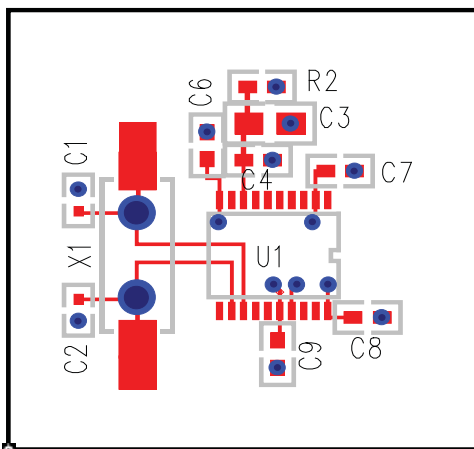

**FIGURE 4A. 843002-01 SCHEMATIC EXAMPLE**

**PC BOARD LAYOUT EXAMPLE**

Figure 4B shows an example of 843002-01 P.C. board layout. The crystal X1 footprint shown in this example allows installation of either surface mount HC49S or through-hole HC49 package. The footprints of other components in this example are listed in

the Table 6. There should be at least one decoupling capacitor per power pin. The decoupling capacitors should be located as close as possible to the power pins. The layout assumes that the board has clean analog power ground plane.



**FIGURE 4B. 843002-01 PC BOARD LAYOUT EXAMPLE**

**TABLE 6. FOOTPRINT TABLE**

Reference	Size
C1, C2	0402
C3	
C4, C5, C6, C7, C8	
R2	

NOTE: Table 6, lists component sizes shown in this layout example.

## POWER CONSIDERATIONS

This section provides information on power dissipation and junction temperature for the 843002-01. Equations and example calculations are also provided.

### 1. Power Dissipation.

The total power dissipation for the 843002-01 is the sum of the core power plus the power dissipated in the load(s). The following is the power dissipation for  $V_{CC} = 3.3V + 10\% = 3.63V$ , which gives worst case results.

**NOTE:** Please refer to Section 3 for details on calculating power dissipated in the load.

- Power (core)<sub>MAX</sub> =  $V_{CC\_MAX} * I_{EE\_MAX} = 3.63V * 135mA = 490mW$
- Power (outputs)<sub>MAX</sub> = **30mW/Loaded Output pair**  
If all outputs are loaded, the total power is  $2 * 30mW = 60mW$

**Total Power**<sub>MAX</sub> (3.63V, with all outputs switching) =  $490mW + 60mW = 550mW$

### 2. Junction Temperature.

Junction temperature, T<sub>j</sub>, is the temperature at the junction of the bond wire and bond pad and directly affects the reliability of the device. The maximum recommended junction temperature for HiPerClockS™ devices is 125°C.

The equation for T<sub>j</sub> is as follows:  $T_j = \theta_{JA} * Pd\_total + T_A$

T<sub>j</sub> = Junction Temperature

$\theta_{JA}$  = Junction-to-Ambient Thermal Resistance

Pd<sub>total</sub> = Total Device Power Dissipation (example calculation is in section 1 above)

T<sub>A</sub> = Ambient Temperature

In order to calculate junction temperature, the appropriate junction-to-ambient thermal resistance  $\theta_{JA}$  must be used. Assuming a moderate air flow of 200 linear feet per minute and a multi-layer board, the appropriate value is 66.6°C/W per Table 7 below.

Therefore, T<sub>j</sub> for an ambient temperature of 85°C with all outputs switching is:

$$85^\circ C + 0.550W * 66.6^\circ C/W = 121.6^\circ C. \text{ This is below the limit of } 125^\circ C.$$

This calculation is only an example. T<sub>j</sub> will obviously vary depending on the number of loaded outputs, supply voltage, air flow, and the type of board (single layer or multi-layer).

**TABLE 7. THERMAL RESISTANCE  $\theta_{JA}$  FOR 20-PIN TSSOP, FORCED CONVECTION**

<b><math>\theta_{JA}</math> by Velocity (Linear Feet per Minute)</b>			
	<b>0</b>	<b>200</b>	<b>500</b>
Single-Layer PCB, JEDEC Standard Test Boards	114.5°C/W	98.0°C/W	88.0°C/W
Multi-Layer PCB, JEDEC Standard Test Boards	73.2°C/W	66.6°C/W	63.5°C/W

**NOTE:** Most modern PCB designs use multi-layered boards. The data in the second row pertains to most designs.

3. Calculations and Equations.

The purpose of this section is to derive the power dissipated into the load.

LVPECL output driver circuit and termination are shown in Figure 5.

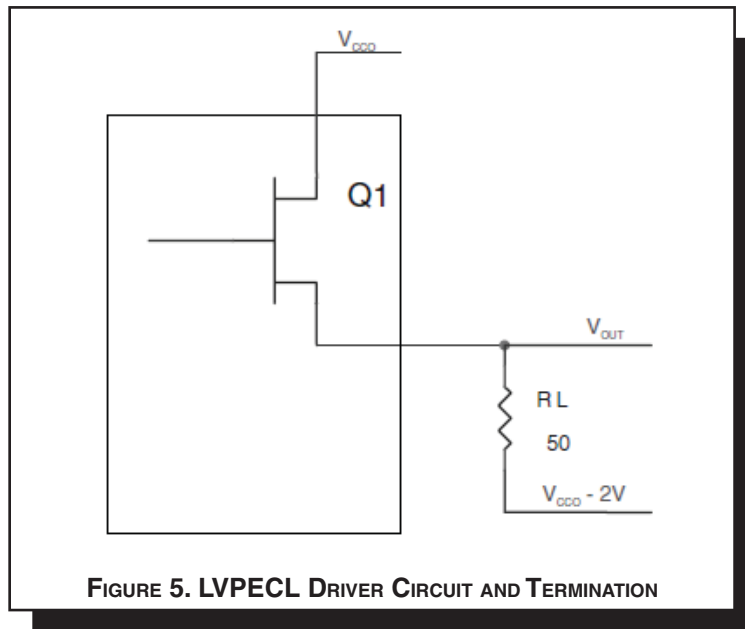

To calculate worst case power dissipation into the load, use the following equations which assume a 50Ω load, and a termination voltage of  $V_{CCO} - 2V$ .

- For logic high,  $V_{OUT} = V_{OH\_MAX} = V_{CCO\_MAX} - 0.9V$   
 $(V_{CCO\_MAX} - V_{OH\_MAX}) = 0.9V$
- For logic low,  $V_{OUT} = V_{OL\_MAX} = V_{CCO\_MAX} - 1.7V$   
 $(V_{CCO\_MAX} - V_{OL\_MAX}) = 1.7V$

$Pd\_H$  is power dissipation when the output drives high.  
 $Pd\_L$  is the power dissipation when the output drives low.

$$Pd\_H = [(V_{OH\_MAX} - (V_{CCO\_MAX} - 2V))/R_L] * (V_{CCO\_MAX} - V_{OH\_MAX}) = [(2V - (V_{CCO\_MAX} - V_{OH\_MAX}))/R_L] * (V_{CCO\_MAX} - V_{OH\_MAX}) = [(2V - 0.9V)/50\Omega] * 0.9V = 19.8mW$$

$$Pd\_L = [(V_{OL\_MAX} - (V_{CCO\_MAX} - 2V))/R_L] * (V_{CCO\_MAX} - V_{OL\_MAX}) = [(2V - (V_{CCO\_MAX} - V_{OL\_MAX}))/R_L] * (V_{CCO\_MAX} - V_{OL\_MAX}) = [(2V - 1.7V)/50\Omega] * 1.7V = 10.2mW$$

Total Power Dissipation per output pair =  $Pd\_H + Pd\_L = 30mW$

## RELIABILITY INFORMATION

**TABLE 8.  $\theta_{JA}$  VS. AIR FLOW TABLE FOR 20 LEAD TSSOP**

$\theta_{JA}$ by Velocity (Linear Feet per Minute)			
	<b>0</b>	<b>200</b>	<b>500</b>
Single-Layer PCB, JEDEC Standard Test Boards	114.5°C/W	98.0°C/W	88.0°C/W
Multi-Layer PCB, JEDEC Standard Test Boards	73.2°C/W	66.6°C/W	63.5°C/W

**NOTE:** Most modern PCB designs use multi-layered boards. The data in the second row pertains to most designs.

### TRANSISTOR COUNT

The transistor count for 843002-01 is: 2955

PACKAGE OUTLINE - G SUFFIX FOR 20 LEAD TSSOP

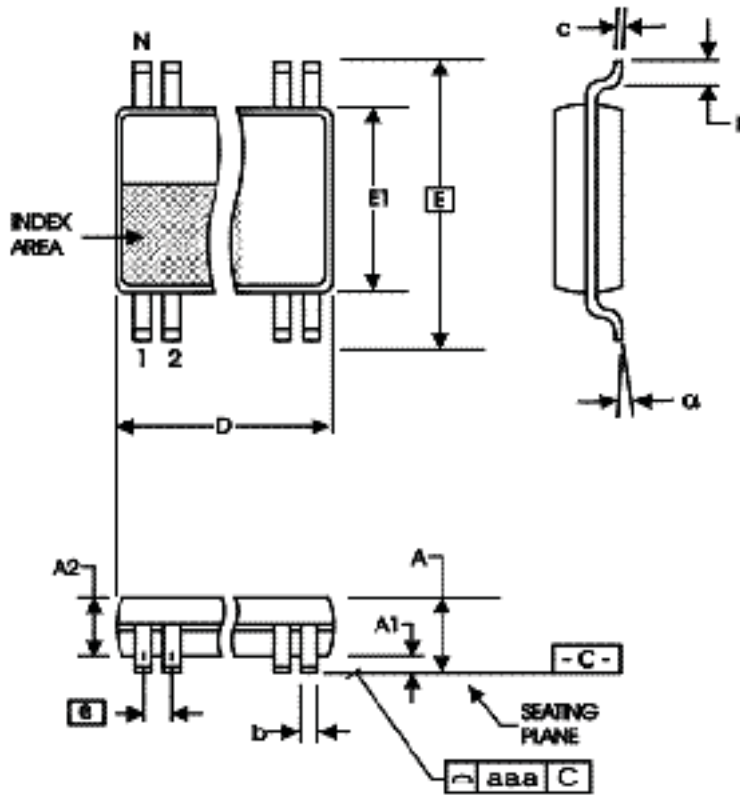

TABLE 9. PACKAGE DIMENSIONS

SYMBOL	Millimeters	
	MIN	MAX
N	20	
A	--	1.20
A1	0.05	0.15
A2	0.80	1.05
b	0.19	0.30
c	0.09	0.20
D	6.40	6.60
E	6.40 BASIC	
E1	4.30	4.50
e	0.65 BASIC	
L	0.45	0.75
α	0°	8°
aaa	--	0.10

Reference Document: JEDEC Publication 95, MO-153

**TABLE 10. ORDERING INFORMATION**

Part/Order Number	Marking	Package	Shipping Packaging	Temperature
ICS843002AG-01LF	ICS43002A01L	20 Lead "Lead-Free" TSSOP	tube	-30°C to 85°C
ICS843002AG-01LFT	ICS43002A01L	20 Lead "Lead-Free" TSSOP	tape & reel	-30°C to 85°C

NOTE: Parts that are ordered with an "LF" to the part number are the Pb-Free configuration and are RoHS compliant.

REVISION HISTORY SHEET				
Rev	Table	Page	Description of Change	Date
A	T10	1 15	Added Lead-Free bullet in Features Section. Added Lead-Free Part/Order Number in Ordering Information table.	1/5/05
A	T10	15	Added Lead-Free Marking to Ordering Information Table.	1/11/05
B	T5	4	AC Characteristics Table - delete Propagation Delay.	5/6/05
B	T10	15	Ordering Information - removed leaded devices. Updated datasheet format.	4/6/15



## IMPORTANT NOTICE AND DISCLAIMER

RENESAS ELECTRONICS CORPORATION AND ITS SUBSIDIARIES (“RENESAS”) PROVIDES TECHNICAL SPECIFICATIONS AND RELIABILITY DATA (INCLUDING DATASHEETS), DESIGN RESOURCES (INCLUDING REFERENCE DESIGNS), APPLICATION OR OTHER DESIGN ADVICE, WEB TOOLS, SAFETY INFORMATION, AND OTHER RESOURCES “AS IS” AND WITH ALL FAULTS, AND DISCLAIMS ALL WARRANTIES, EXPRESS OR IMPLIED, INCLUDING, WITHOUT LIMITATION, ANY IMPLIED WARRANTIES OF MERCHANTABILITY, FITNESS FOR A PARTICULAR PURPOSE, OR NON-INFRINGEMENT OF THIRD-PARTY INTELLECTUAL PROPERTY RIGHTS.

These resources are intended for developers who are designing with Renesas products. You are solely responsible for (1) selecting the appropriate products for your application, (2) designing, validating, and testing your application, and (3) ensuring your application meets applicable standards, and any other safety, security, or other requirements. These resources are subject to change without notice. Renesas grants you permission to use these resources only to develop an application that uses Renesas products. Other reproduction or use of these resources is strictly prohibited. No license is granted to any other Renesas intellectual property or to any third-party intellectual property. Renesas disclaims responsibility for, and you will fully indemnify Renesas and its representatives against, any claims, damages, costs, losses, or liabilities arising from your use of these resources. Renesas' products are provided only subject to Renesas' Terms and Conditions of Sale or other applicable terms agreed to in writing. No use of any Renesas resources expands or otherwise alters any applicable warranties or warranty disclaimers for these products.

(Disclaimer Rev.1.01 Jan 2024)

### Corporate Headquarters

TOYOSU FORESIA, 3-2-24 Toyosu,  
Koto-ku, Tokyo 135-0061, Japan  
[www.renesas.com](http://www.renesas.com)

### Trademarks

Renesas and the Renesas logo are trademarks of Renesas Electronics Corporation. All trademarks and registered trademarks are the property of their respective owners.

### Contact Information

For further information on a product, technology, the most up-to-date version of a document, or your nearest sales office, please visit [www.renesas.com/contact-us/](http://www.renesas.com/contact-us/).

## Looking for pricing, stock, or lifecycle information?

Click below to explore more details on WIN SOURCE:

-  [View 843002AG-01LF on WIN SOURCE](#)
-  [Renesas Electronics America](#) Information

## Optimize Your Supply Chain with WIN SOURCE Solutions

-  Global Sourcing Solution
-  Obsolete Management
-  Cost Control Management
-  Shortage Management
-  Alternative Solution
-  Excess Inventory Management