



THE DATASHEET OF
8312AYLF



General Description

The 8312 is a low skew, 1-to-12 LVCMOS/ LVTTL Fanout Buffer and a member of the family of High Performance Clock Solutions from IDT. The 8312 single-ended clock input accepts LVCMOS or LVTTL input levels. The low impedance LVCMOS outputs are designed to drive 50Ω series or parallel terminated transmission lines. The effective fanout can be increased from 12 to 24 by utilizing the ability of the outputs to drive two series terminated lines.

The 8312 is characterized at full 3.3V, 2.5V, and 1.8V, mixed 3.3V/2.5V, 3.3V/1.8V and 2.5V/1.8V output operating supply modes. Guaranteed output and part-to-part skew characteristics along with the 1.8V output capabilities makes the 8312 ideal for high performance, single ended applications that also require a limited output voltage.

Features

- Twelve LVCMOS/LVTTL outputs
- CLK input supports the following input types: LVCMOS, LVTTL
- Maximum output frequency: 250MHz
- Output skew: 150ps (maximum)
- Supply modes:
Core/Output
3.3V/3.3V
3.3V/2.5V
3.3V/1.8V
2.5V/2.5V
2.5V/1.8V
1.8V/1.8V
- 0°C to 85°C ambient operating temperature
- Available in lead-free (RoHS 6) package

Block Diagram

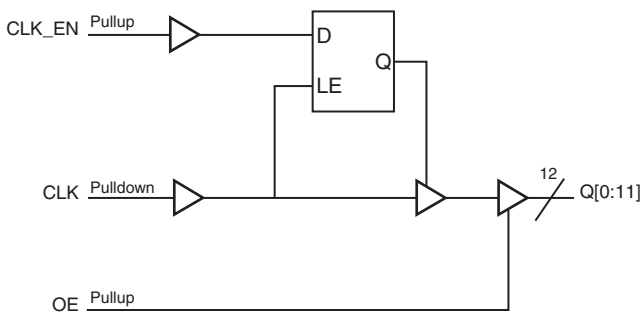

Pin Assignment

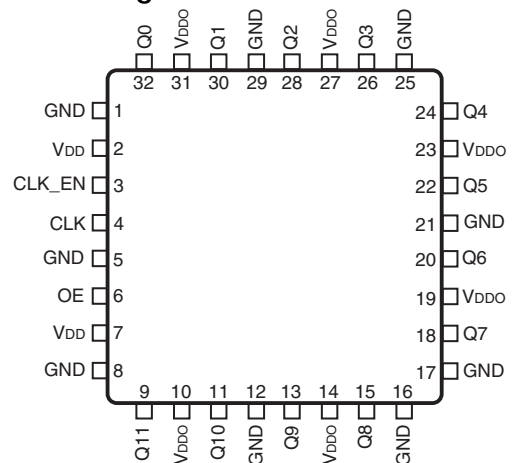

8312

32-Lead LQFP

7mm x 7mm x 1.4mm package body

Y Package

Top View

Table 1. Pin Descriptions

Number	Name	Type		Description
1, 5, 8, 12, 16, 17, 21, 25, 29	GND	Power		Power supply ground.
2, 7	V _{DD}	Power		Positive supply pins.
3	CLK_EN	Input	Pullup	Synchronous control for enabling and disabling clock outputs. LVCMOS / LVTTTL interface levels.
4	CLK	Input	Pulldown	Single-ended clock input. LVCMOS/LVTTTL interface levels.
6	OE	Input	Pullup	Output enable. Controls enabling and disabling of outputs Q[0:11]. LVCMOS / LVTTTL interface levels.
9, 11, 13, 15, 18, 20, 22, 24, 26, 28, 30, 32	Q11, Q10, Q9, Q8, Q7, Q6, Q5, Q4, Q3, Q2, Q1, Q0	Output		Single-ended clock outputs. LVCMOS/LVTTTL interface levels.
10, 14, 19, 23, 27, 31	V _{DDO}	Power		Output supply pins.

NOTE: Pullup and Pulldown refer to internal input resistors. See Table 2, Pin Characteristics, for typical values.

Table 2. Pin Characteristics

Symbol	Parameter	Test Conditions	Minimum	Typical	Maximum	Units
C _{IN}	Input Capacitance			4		pF
R _{PULLUP}	Input Pullup Resistor			51		kΩ
R _{PULLDOWN}	Input Pulldown Resistor			51		kΩ
C _{PD}	Power Dissipation Capacitance (per output)	V _{DDO} = 3.465V			19	pF
		V _{DDO} = 2.625V			18	pF
		V _{DDO} = 2V			16	pF
R _{OUT}	Output Impedance	V _{DDO} = 3.3V ± 5%		7		Ω
		V _{DDO} = 2.5V ± 5%		7		Ω
		V _{DDO} = 1.8V ± 0.2V		10		Ω

Function Tables

Table 3A. Output Enable and Clock Enable Function Table

Inputs		Outputs
OE	CLK_EN	Q [0:11]
0	X	Hi-Z
1	0	LOW
1	1	Follows CLK input

Table 3B. Output Enable and Clock Enable Function Table

Inputs			Outputs
OE	CLK_EN	CLK	Q [0:11]
1	1	0	LOW
1	1	1	HIGH

Absolute Maximum Ratings

NOTE: Stresses beyond those listed under *Absolute Maximum Ratings* may cause permanent damage to the device. These ratings are stress specifications only. Functional operation of product at these conditions or any conditions beyond those listed in the *DC Characteristics* or *AC Characteristics* is not implied. Exposure to absolute maximum rating conditions for extended periods may affect product reliability.

Item	Rating
Supply Voltage, V_{DD}	4.6V
Inputs, V_I	-0.5V to $V_{DD} + 0.5V$
Outputs, V_O	-0.5V to $V_{DDO} + 0.5V$
Package Thermal Impedance, θ_{JA}	47.9°C/W (0 lfm)
Storage Temperature, T_{STG}	-65°C to 150°C

DC Electrical Characteristics

Table 4A. Power Supply DC Characteristics, $V_{DD} = V_{DDO} = 3.3V \pm 5\%$, $T_A = 0^\circ C$ to $85^\circ C$

Symbol	Parameter	Test Conditions	Minimum	Typical	Maximum	Units
V_{DD}	Positive Supply Voltage		3.135	3.3	3.465	V
V_{DDO}	Output Supply Voltage		3.135	3.3	3.465	V
I_{DD}	Power Supply Current				10	mA
I_{DDO}	Output Supply Current				10	mA

Table 4B. Power Supply DC Characteristics, $V_{DD} = V_{DDO} = 2.5V \pm 5\%$, $T_A = 0^\circ C$ to $85^\circ C$

Symbol	Parameter	Test Conditions	Minimum	Typical	Maximum	Units
V_{DD}	Positive Supply Voltage		2.375	2.5	2.625	V
V_{DDO}	Output Supply Voltage		2.375	2.5	2.625	V
I_{DD}	Power Supply Current				10	mA
I_{DDO}	Output Supply Current				10	mA

Table 4C. Power Supply DC Characteristics, $V_{DD} = V_{DDO} = 1.8V \pm 0.2V$, $T_A = 0^\circ C$ to $85^\circ C$

Symbol	Parameter	Test Conditions	Minimum	Typical	Maximum	Units
V_{DD}	Positive Supply Voltage		1.6	1.8	2.0	V
V_{DDO}	Output Supply Voltage		1.6	1.8	2.0	V
I_{DD}	Power Supply Current				10	mA
I_{DDO}	Output Supply Current				10	mA

Table 4D. Power Supply DC Characteristics, $V_{DD} = 3.3V \pm 5\%$, $V_{DDO} = 2.5V \pm 5\%$, $T_A = 0^\circ\text{C}$ to 85°C

Symbol	Parameter	Test Conditions	Minimum	Typical	Maximum	Units
V_{DD}	Positive Supply Voltage		3.135	3.3	3.465	V
V_{DDO}	Output Supply Voltage		2.375	2.5	2.625	V
I_{DD}	Power Supply Current				10	mA
I_{DDO}	Output Supply Current				10	mA

Table 4E. Power Supply DC Characteristics, $V_{DD} = 3.3V \pm 5\%$, $V_{DDO} = 1.8V \pm 0.2V$, $T_A = 0^\circ\text{C}$ to 85°C

Symbol	Parameter	Test Conditions	Minimum	Typical	Maximum	Units
V_{DD}	Positive Supply Voltage		3.135	3.3	3.465	V
V_{DDO}	Output Supply Voltage		1.6	1.8	2.0	V
I_{DD}	Power Supply Current				10	mA
I_{DDO}	Output Supply Current				10	mA

Table 4F. Power Supply DC Characteristics, $V_{DD} = 2.5V \pm 5\%$, $V_{DDO} = 1.8V \pm 0.2V$, $T_A = 0^\circ\text{C}$ to 85°C

Symbol	Parameter	Test Conditions	Minimum	Typical	Maximum	Units
V_{DD}	Positive Supply Voltage		2.375	2.5	2.625	V
V_{DDO}	Output Supply Voltage		1.6	1.8	2.0	V
I_{DD}	Power Supply Current				10	mA
I_{DDO}	Output Supply Current				10	mA

Table 4G. LVC MOS/LVTTL DC Characteristics, $T_A = 0^\circ\text{C}$ to 85°C

Symbol	Parameter		Test Conditions	Minimum	Typical	Maximum	Units
V_{IH}	Input High Voltage		$V_{DD} = 3.465\text{V}$	2		$V_{DD} + 0.3$	V
			$V_{DD} = 2.625\text{V}$	1.7		$V_{DD} + 0.3$	V
			$V_{DD} = 2.0\text{V}$	$0.65 \cdot V_{DD}$		$V_{DD} + 0.3$	V
V_{IL}	Input Low Voltage		$V_{DD} = 3.465\text{V}$	-0.3		1.3	V
			$V_{DD} = 2.625\text{V}$	-0.3		0.7	V
			$V_{DD} = 2.0\text{V}$	-0.3		$0.35 \cdot V_{DD}$	V
I_{IH}	Input High Current	CLK	$V_{DD} = V_{IN} = 3.465\text{V}$ or 2.625V or 2.0V			150	μA
		OE, CLK_EN	$V_{DD} = V_{IN} = 3.465\text{V}$ or 2.625V or 2.0V			5	μA
I_{IL}	Input Low Current	CLK	$V_{DD} = 3.465\text{V}$ or 2.625V or 2.0V , $V_{IN} = 0\text{V}$	-5			μA
		OE, CLK_EN	$V_{DD} = 3.465\text{V}$ or 2.625V or 2.0V , $V_{IN} = 0\text{V}$	-150			μA
V_{OH}	Output High Voltage; NOTE 1		$V_{DDO} = 3.3\text{V} \pm 5\%$	2.6			V
			$V_{DDO} = 2.5\text{V} \pm 5\%$;	1.8			V
			$V_{DDO} = 2.5\text{V} \pm 5\%$; $I_{OH} = -1\text{mA}$	2			V
			$V_{DDO} = 1.8\text{V} \pm 0.2\text{V}$	$V_{DD} - 0.3$			V
			$V_{DDO} = 1.8\text{V} \pm 0.2\text{V}$; $I_{OH} = -100\mu\text{A}$	$V_{DD} - 0.2$			V
V_{OL}	Output Low Voltage; NOTE 1		$V_{DDO} = 3.3\text{V} \pm 5\%$			0.5	V
			$V_{DDO} = 2.5\text{V} \pm 5\%$;			0.45	V
			$V_{DDO} = 2.5\text{V} \pm 5\%$; $I_{OL} = 1\text{mA}$			0.4	V
			$V_{DDO} = 1.8\text{V} \pm 0.2\text{V}$			0.35	V
			$V_{DDO} = 1.8\text{V} \pm 0.2\text{V}$; $I_{OL} = 100\mu\text{A}$			0.2	V

NOTE 1: Outputs terminated with 50Ω to $V_{DDO}/2$. See Parameter Measurement Information, *Output Load Test Circuit diagrams*.

AC Electrical Characteristics

Table 5A. AC Characteristics, $V_{DD} = V_{DDO} = 3.3V \pm 5\%$, $T_A = 0^\circ C$ to $85^\circ C$

Parameter	Symbol	Test Conditions	Minimum	Typical	Maximum	Units
f_{MAX}	Output Frequency				250	MHz
tp_{LH}	Propagation Delay, Low to High; NOTE 1	$f \leq 250MHz$	1.2	1.9	2.5	ns
tjit	Buffer Additive Phase Jitter, RMS; refer to Additive Phase Jitter Section	100MHz, Integration Range: 12kHz – 20MHz		0.037		ps
$tsk(o)$	Output Skew; NOTE 2, 5				125	ps
$tsk(pp)$	Part-to-Part Skew; NOTE 3, 5				800	ps
t_R / t_F	Output Rise/Fall Time; NOTE 5	20% to 80%	200		700	ps
odc	Output Duty Cycle	$f \leq 200MHz$	45		55	%

All parameters measured at f_{MAX} unless noted otherwise.

NOTE 1: Measured from the $V_{DD}/2$ of the input to $V_{DDO}/2$ of the output.

NOTE 2: Defined as skew between outputs at the same supply voltage and with equal load conditions. Measured at $V_{DDO}/2$.

NOTE 3: Defined as skew between outputs on different devices operating at the same supply voltage and with equal load conditions. Using the same type of input on each device, the output is measured at $V_{DDO}/2$.

NOTE 4: These parameters are guaranteed by characterization. Not tested in production.

NOTE 5: This parameter is defined in accordance with JEDEC Standard 65.

Table 5B. AC Characteristics, $V_{DD} = V_{DDO} = 2.5V \pm 5\%$, $T_A = 0^\circ C$ to $85^\circ C$

Parameter	Symbol	Test Conditions	Minimum	Typical	Maximum	Units
f_{MAX}	Output Frequency				250	MHz
tp_{LH}	Propagation Delay, Low to High; NOTE 1	$f \leq 250MHz$	1.4	2.3	3.2	ns
tjit	Buffer Additive Phase Jitter, RMS; refer to Additive Phase Jitter Section	100MHz, Integration Range: 12kHz – 20MHz		0.022		ps
$tsk(o)$	Output Skew; NOTE 2, 5				150	ps
$tsk(pp)$	Part-to-Part Skew; NOTE 3, 5				1.1	ns
t_R / t_F	Output Rise/Fall Time; NOTE 5	20% to 80%	200		700	ps
odc	Output Duty Cycle	$f \leq 150MHz$	45		55	%

All parameters measured at f_{MAX} unless noted otherwise.

NOTE 1: Measured from the $V_{DD}/2$ of the input to $V_{DDO}/2$ of the output.

NOTE 2: Defined as skew between outputs at the same supply voltage and with equal load conditions. Measured at $V_{DDO}/2$.

NOTE 3: Defined as skew between outputs on different devices operating at the same supply voltage and with equal load conditions. Using the same type of input on each device, the output is measured at $V_{DDO}/2$.

NOTE 4: These parameters are guaranteed by characterization. Not tested in production.

NOTE 5: This parameter is defined in accordance with JEDEC Standard 65.

Table 5C. AC Characteristics, $V_{DD} = V_{DDO} = 1.8V \pm 0.2V$, $T_A = 0^{\circ}C$ to $85^{\circ}C$

Parameter	Symbol	Test Conditions	Minimum	Typical	Maximum	Units
f_{MAX}	Output Frequency				200	MHz
tp_{LH}	Propagation Delay, Low to High; NOTE 1	$f \leq 200MHz$	1.6	3.3	4.8	ns
t_{jit}	Buffer Additive Phase Jitter, RMS; refer to Additive Phase Jitter Section	100MHz, Integration Range: 12kHz – 20MHz		0.172		ps
$t_{sk(o)}$	Output Skew; NOTE 2, 5				140	ps
$t_{sk(pp)}$	Part-to-Part Skew; NOTE 3, 5				2.3	ns
t_R / t_F	Output Rise/Fall Time; NOTE 5	20% to 80%	200		800	ps
odc	Output Duty Cycle	$f \leq 100MHz$	45		55	%

All parameters measured at f_{MAX} unless noted otherwise.

NOTE 1: Measured from the $V_{DD}/2$ of the input to $V_{DDO}/2$ of the output.

NOTE 2: Defined as skew between outputs at the same supply voltage and with equal load conditions. Measured at $V_{DDO}/2$.

NOTE 3: Defined as skew between outputs on different devices operating at the same supply voltage and with equal load conditions.

Using the same type of input on each device, the output is measured at $V_{DDO}/2$.

NOTE 4: These parameters are guaranteed by characterization. Not tested in production.

NOTE 5: This parameter is defined in accordance with JEDEC Standard 65.

Table 5D. AC Characteristics, $V_{DD} = 3.3V \pm 5\%$, $V_{DDO} = 2.5V \pm 5\%$, $T_A = 0^{\circ}C$ to $85^{\circ}C$

Parameter	Symbol	Test Conditions	Minimum	Typical	Maximum	Units
f_{MAX}	Output Frequency				250	MHz
tp_{LH}	Propagation Delay, Low to High; NOTE 1	$f \leq 250MHz$	1.4	2.1	2.7	ns
t_{jit}	Buffer Additive Phase Jitter, RMS; refer to Additive Phase Jitter Section	100MHz, Integration Range: 12kHz – 20MHz		0.045		ps
$t_{sk(o)}$	Output Skew; NOTE 2, 5				135	ps
$t_{sk(pp)}$	Part-to-Part Skew; NOTE 3, 5				900	ps
t_R / t_F	Output Rise/Fall Time; NOTE 5	20% to 80%	200		700	ps
odc	Output Duty Cycle	$f \leq 150MHz$	45		55	%

All parameters measured at f_{MAX} unless noted otherwise.

NOTE 1: Measured from the $V_{DD}/2$ of the input to $V_{DDO}/2$ of the output.

NOTE 2: Defined as skew between outputs at the same supply voltage and with equal load conditions. Measured at $V_{DDO}/2$.

NOTE 3: Defined as skew between outputs on different devices operating at the same supply voltage and with equal load conditions.

Using the same type of input on each device, the output is measured at $V_{DDO}/2$.

NOTE 4: These parameters are guaranteed by characterization. Not tested in production.

NOTE 5: This parameter is defined in accordance with JEDEC Standard 65.

Table 5E. AC Characteristics, $V_{DD} = 3.3V \pm 5\%$, $V_{DDO} = 1.8V \pm 0.2V$, $T_A = 0^\circ C$ to $85^\circ C$

Parameter	Symbol	Test Conditions	Minimum	Typical	Maximum	Units
f_{MAX}	Output Frequency				200	MHz
tp_{LH}	Propagation Delay, Low to High; NOTE 1	$f \leq 200MHz$	1.4	2.4	3.4	ns
t_{jit}	Buffer Additive Phase Jitter, RMS; refer to Additive Phase Jitter Section	100MHz, Integration Range: 12kHz – 20MHz		0.136		ps
$t_{sk(o)}$	Output Skew; NOTE 2, 5				145	ps
$t_{sk(pp)}$	Part-to-Part Skew; NOTE 3, 5				1.3	ns
t_R / t_F	Output Rise/Fall Time; NOTE 5	20% to 80%	200		700	ps
odc	Output Duty Cycle	$f \leq 100MHz$	45		55	%

All parameters measured at f_{MAX} unless noted otherwise.

NOTE 1: Measured from the $V_{DD}/2$ of the input to $V_{DDO}/2$ of the output.

NOTE 2: Defined as skew between outputs at the same supply voltage and with equal load conditions. Measured at $V_{DDO}/2$.

NOTE 3: Defined as skew between outputs on different devices operating at the same supply voltage and with equal load conditions.

Using the same type of input on each device, the output is measured at $V_{DDO}/2$.

NOTE 4: These parameters are guaranteed by characterization. Not tested in production.

NOTE 5: This parameter is defined in accordance with JEDEC Standard 65.

Table 5F. AC Characteristics, $V_{DD} = 2.5V \pm 5\%$, $V_{DDO} = 1.8V \pm 0.2V$, $T_A = 0^\circ C$ to $85^\circ C$

Parameter	Symbol	Test Conditions	Minimum	Typical	Maximum	Units
f_{MAX}	Output Frequency				200	MHz
tp_{LH}	Propagation Delay, Low to High; NOTE 1	$f \leq 200MHz$	1.5	2.6	3.7	ns
t_{jit}	Buffer Additive Phase Jitter, RMS; refer to Additive Phase Jitter Section	100MHz, Integration Range: 12kHz – 20MHz		0.114		ps
$t_{sk(o)}$	Output Skew; NOTE 2, 5				150	ps
$t_{sk(pp)}$	Part-to-Part Skew; NOTE 3, 5				1.5	ns
t_R / t_F	Output Rise/Fall Time; NOTE 5	20% to 80%	200		700	ps
odc	Output Duty Cycle	$f \leq 100MHz$	45		55	%

All parameters measured at f_{MAX} unless noted otherwise.

NOTE 1: Measured from the $V_{DD}/2$ of the input to $V_{DDO}/2$ of the output.

NOTE 2: Defined as skew between outputs at the same supply voltage and with equal load conditions. Measured at $V_{DDO}/2$.

NOTE 3: Defined as skew between outputs on different devices operating at the same supply voltage and with equal load conditions.

Using the same type of input on each device, the output is measured at $V_{DDO}/2$.

NOTE 4: These parameters are guaranteed by characterization. Not tested in production.

NOTE 5: This parameter is defined in accordance with JEDEC Standard 65.

Additive Phase Jitter

The spectral purity in a band at a specific offset from the fundamental compared to the power of the fundamental is called the **dBc Phase Noise**. This value is normally expressed using a Phase noise plot and is most often the specified plot in many applications. Phase noise is defined as the ratio of the noise power present in a 1Hz band at a specified offset from the fundamental frequency to the power value of the fundamental. This ratio is expressed in decibels (dBm) or a ratio of the power in the 1Hz band

to the power in the fundamental. When the required offset is specified, the phase noise is called a **dBc** value, which simply means dBm at a specified offset from the fundamental. By investigating jitter in the frequency domain, we get a better understanding of its effects on the desired application over the entire time record of the signal. It is mathematically possible to calculate an expected bit error rate given a phase noise plot.

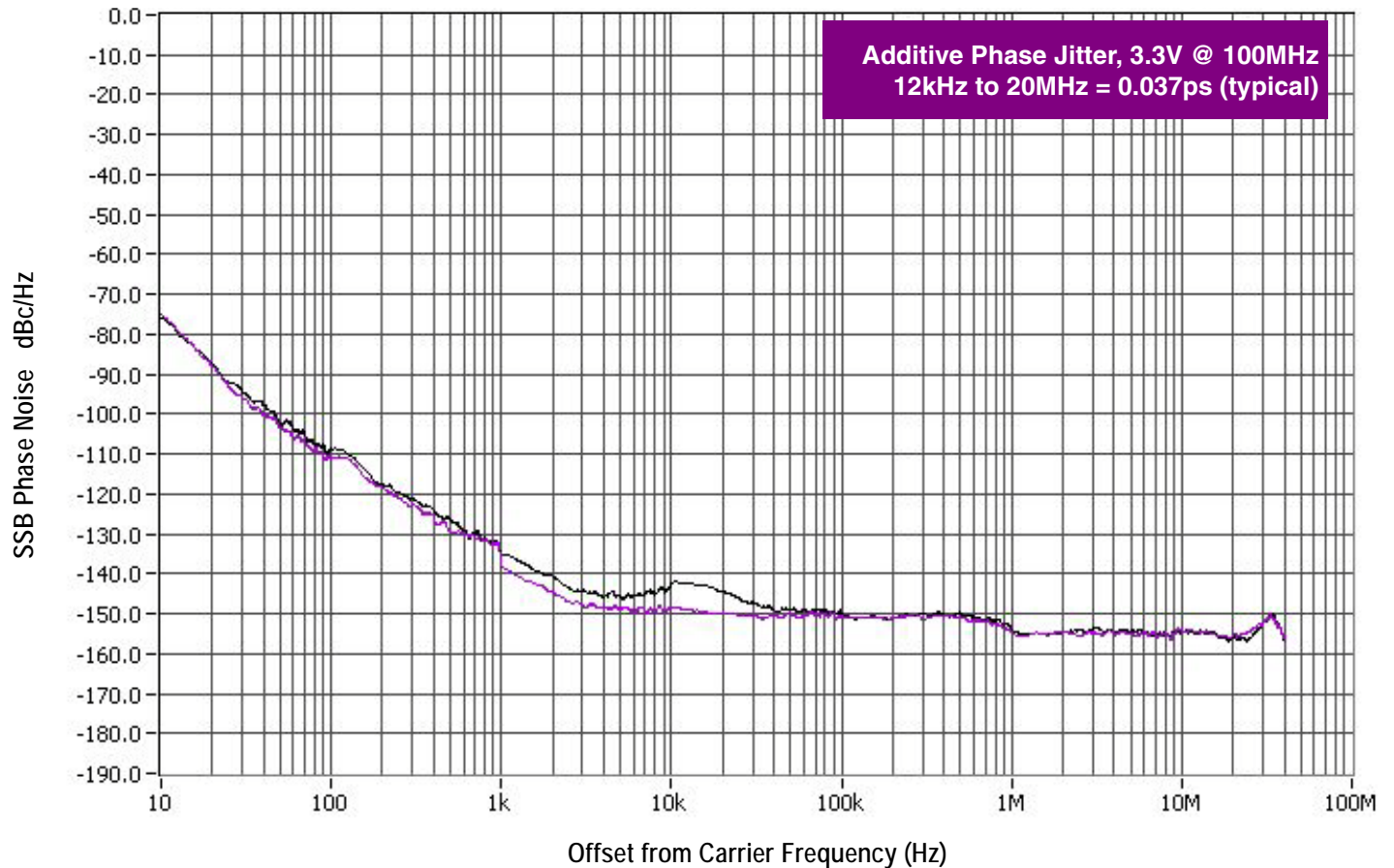

As with most timing specifications, phase noise measurements has issues relating to the limitations of the equipment. Often the noise floor of the equipment is higher than the noise floor of the

device. This is illustrated above. The device meets the noise floor of what is shown, but can actually be lower. The phase noise is dependant on the input source and measurement equipment.

Parameter Measurement Information

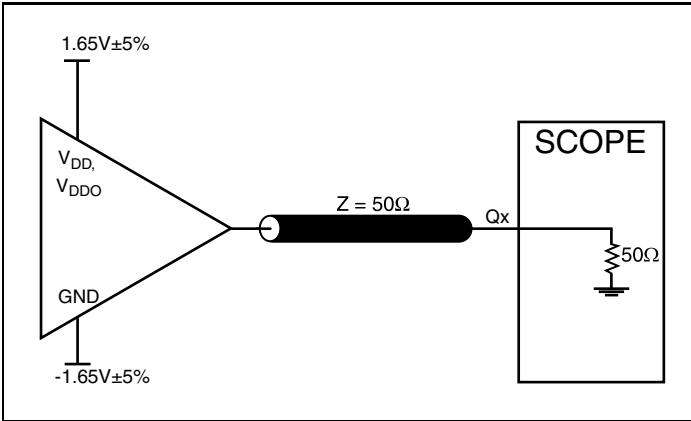

3.3V Core/3.3V LVCMOS Output Load AC Test Circuit

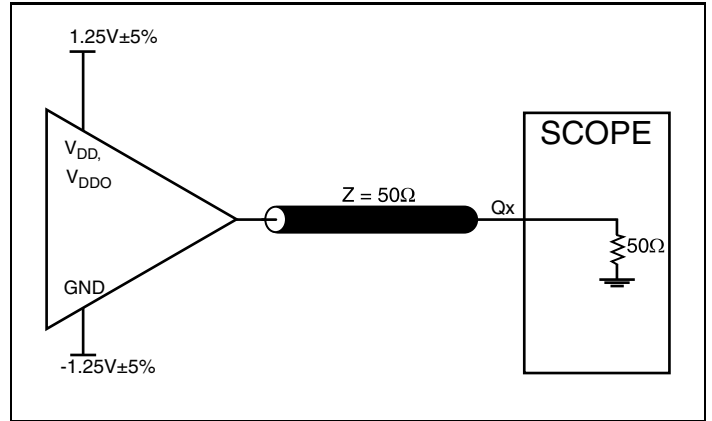

2.5V Core/2.5V LVCMOS Output Load AC Test Circuit

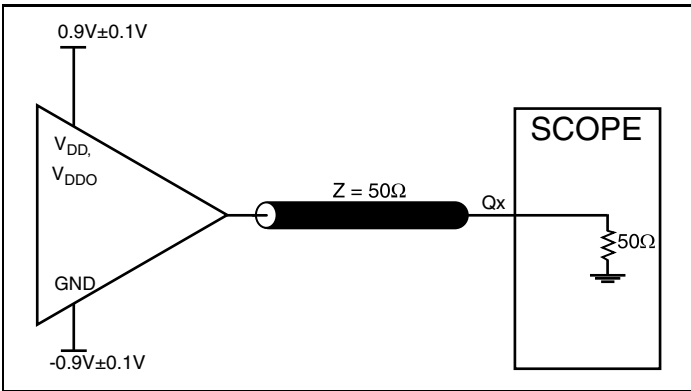

1.8V Core/1.8V LVCMOS Output Load AC Test Circuit

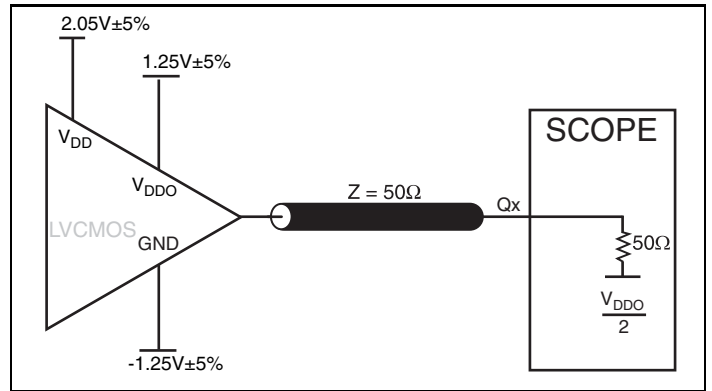

3.3V Core/2.5V LVCMOS Output Load AC Test Circuit

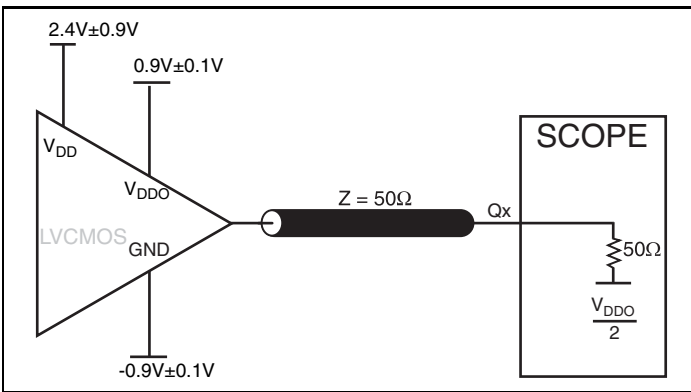

3.3V Core/1.8V LVCMOS Output Load AC Test Circuit

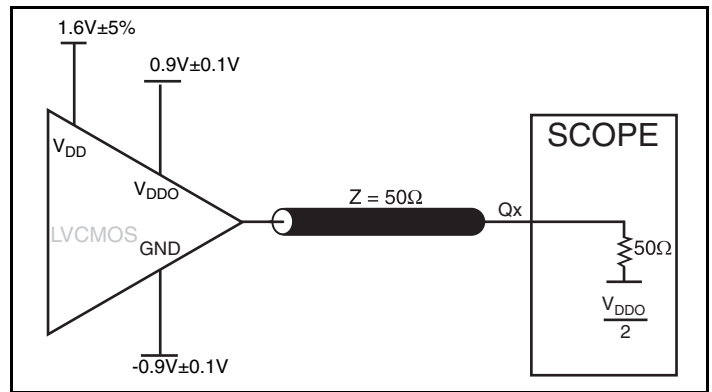

2.5V Core/1.8V LVCMOS Output Load AC Test Circuit

Parameter Measurement Information, continued

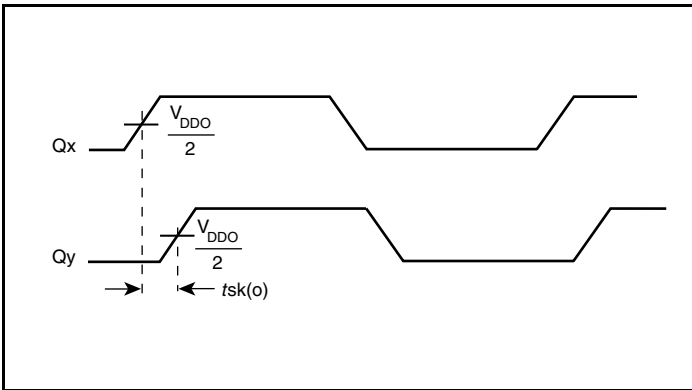

Output Skew

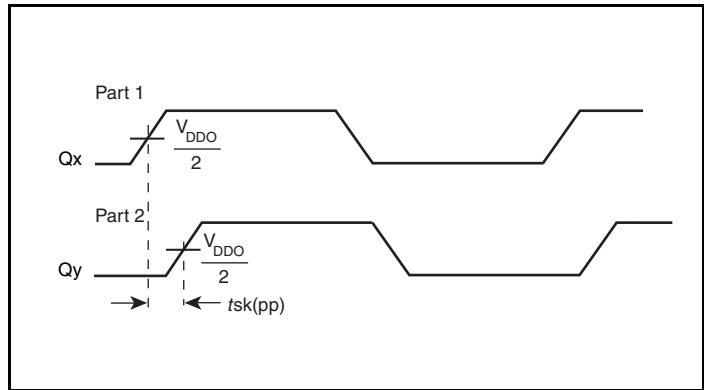

Part-to-Part Skew

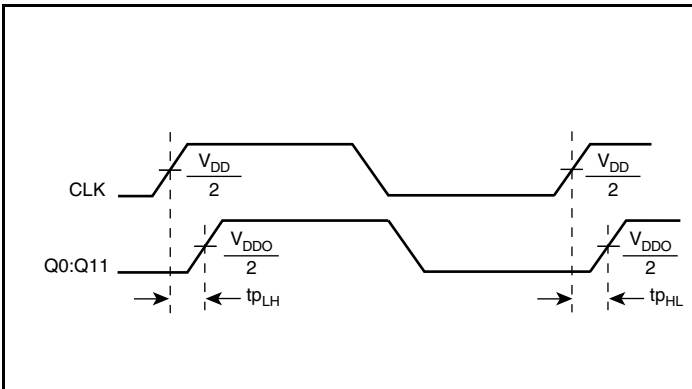

Propagation Delay

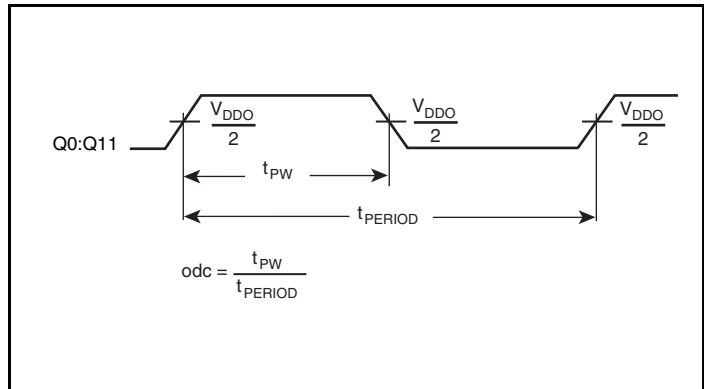

Output Duty Cycle/Pulse Width/Period

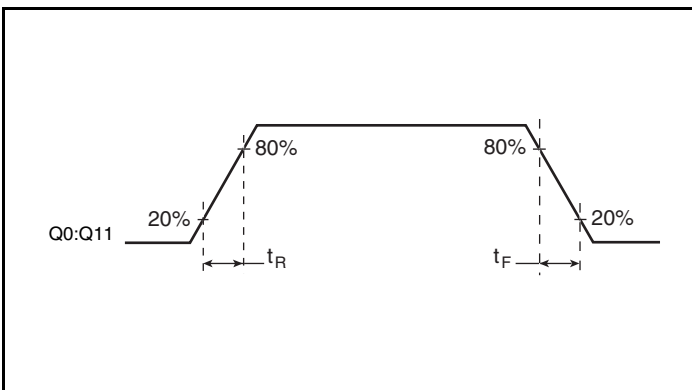

Output Rise/Fall Time

Application Information

Recommendations for Unused Input and Output Pins

Inputs:**LVC MOS Control Pins:**

All control pins have internal pull-ups or pull-downs; additional resistance is not required but can be added for additional protection. A 1k Ω resistor can be used.

Outputs:**LVC MOS Outputs:**

All unused LVC MOS output can be left floating. There should be no trace attached.

Reliability Information

Table 6. θ_{JA} vs. Air Flow Table for a 32 Lead LQFP

θ_{JA} vs. Air Flow			
Linear Feet per Minute	0	200	500
Single-Layer PCB, JEDEC Standard Test Boards	67.8°C/W	55.9°C/W	50.1°C/W
Multi-Layer PCB, JEDEC Standard Test Boards	47.9°C/W	42.1°C/W	39.4°C/W

NOTE: Most modern PCB design use multi-layered boards. The data in the second row pertains to most designs.

Transistor Count

The transistor count for 8312 is: 339

Package Outline and Package Dimensions

Package Outline - Y Suffix for 32 Lead LQFP

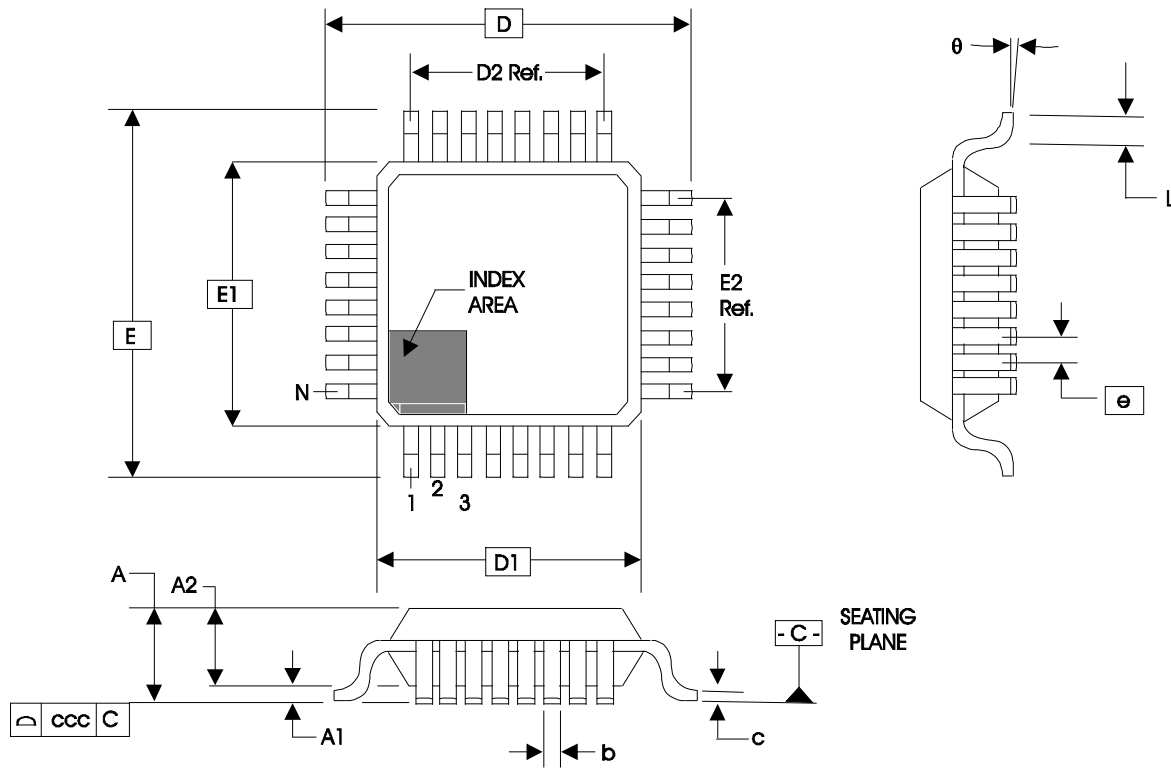

Table 7. Package Dimensions for 32 Lead LQFP

JEDEC Variation: ABC - HD			
All Dimensions in Millimeters			
Symbol	Minimum	Nominal	Maximum
N	32		
A			1.60
A1	0.05	0.10	0.15
A2	1.35	1.40	1.45
b	0.30	0.37	0.45
c	0.09		0.20
D & E	9.00 Basic		
D1 & E1	7.00 Basic		
D2 & E2	5.60 Ref.		
e	0.80 Basic		
L	0.45	0.60	0.75
θ	0°		7°
ccc			0.10
N	32		

Reference Document: JEDEC Publication 95, MS-026

Ordering Information

Table 8. Ordering Information

Part/Order Number	Marking	Package	Shipping Packaging	Temperature
8312AYLF	ICS8312AYLF	"Lead-Free" 32 Lead LQFP	Tray	0°C to 85°C
8312AYLFT	ICS8312AYLF	"Lead-Free" 32 Lead LQFP	Tape & Reel	0°C to 85°C

Revision History Sheet

Rev	Table	Page	Description of Change	Date
B	T2 T4A - T4F	2	Pin Characteristics table - added category C_{PD} .	2/25/03
		3	Power Supply tables - changed I_{DD} & I_{DDO} max. current spec to 10 μ A and removed typical value.	
C	T2	1	Features section - corrected Output Skew typo error from 160ps to 150ps.	5/17/04
		2	Pin Characteristics table - changed C_{IN} 4pF max. to 4pF typical.	
C	T8	11	Added Lead-Free part number to Ordering Information Table.	6/14/04
D	T5A - T5F	7 - 9	Added Additive Phase Jitter specs to AC Tables.	7/3/08
		10	Added Additive Phase Jitter Plot.	
		13	Added <i>Recommendations for Unused Input & Output Pins</i> section. Updated datasheet to new format.	
D	T8	16	Removed leaded orderable parts from Ordering Information table	11/14/12
D		1	Removed ICS Chip and HiPerClockS under General Description.	12/11/15
		1	Removed ICS in the part numbers.	
		16	Removed reference to leaded parts in the Features Section.	
		16	Removed LF note at the bottom of the Ordering Information table. Removed the quantity of 1000 from the Tape & Reel in the Ordering information table. Updated datasheet header and footer.	

IMPORTANT NOTICE AND DISCLAIMER

RENESAS ELECTRONICS CORPORATION AND ITS SUBSIDIARIES (“RENESAS”) PROVIDES TECHNICAL SPECIFICATIONS AND RELIABILITY DATA (INCLUDING DATASHEETS), DESIGN RESOURCES (INCLUDING REFERENCE DESIGNS), APPLICATION OR OTHER DESIGN ADVICE, WEB TOOLS, SAFETY INFORMATION, AND OTHER RESOURCES “AS IS” AND WITH ALL FAULTS, AND DISCLAIMS ALL WARRANTIES, EXPRESS OR IMPLIED, INCLUDING, WITHOUT LIMITATION, ANY IMPLIED WARRANTIES OF MERCHANTABILITY, FITNESS FOR A PARTICULAR PURPOSE, OR NON-INFRINGEMENT OF THIRD-PARTY INTELLECTUAL PROPERTY RIGHTS.

These resources are intended for developers who are designing with Renesas products. You are solely responsible for (1) selecting the appropriate products for your application, (2) designing, validating, and testing your application, and (3) ensuring your application meets applicable standards, and any other safety, security, or other requirements. These resources are subject to change without notice. Renesas grants you permission to use these resources only to develop an application that uses Renesas products. Other reproduction or use of these resources is strictly prohibited. No license is granted to any other Renesas intellectual property or to any third-party intellectual property. Renesas disclaims responsibility for, and you will fully indemnify Renesas and its representatives against, any claims, damages, costs, losses, or liabilities arising from your use of these resources. Renesas' products are provided only subject to Renesas' Terms and Conditions of Sale or other applicable terms agreed to in writing. No use of any Renesas resources expands or otherwise alters any applicable warranties or warranty disclaimers for these products.

(Disclaimer Rev.1.01 Jan 2024)

Corporate Headquarters

TOYOSU FORESIA, 3-2-24 Toyosu,
Koto-ku, Tokyo 135-0061, Japan
www.renesas.com

Trademarks

Renesas and the Renesas logo are trademarks of Renesas Electronics Corporation. All trademarks and registered trademarks are the property of their respective owners.

Contact Information

For further information on a product, technology, the most up-to-date version of a document, or your nearest sales office, please visit www.renesas.com/contact-us/.

Looking for pricing, stock, or lifecycle information?

Click below to explore more details on WIN SOURCE:

-  [View 8312AYLF on WIN SOURCE](#)
-  [Renesas Electronics America](#) Information

Optimize Your Supply Chain with WIN SOURCE Solutions

-  Global Sourcing Solution
-  Obsolete Management
-  Cost Control Management
-  Shortage Management
-  Alternative Solution
-  Excess Inventory Management