



**THE DATASHEET OF
74HCT4852PW-Q100118**





74HC4852-Q100; 74HCT4852-Q100

Dual 4-channel analog multiplexer/demultiplexer with
injection-current effect control

Rev. 3 — 16 April 2024

Product data sheet

1. General description

The 74HC4852-Q100; 74HCT4852-Q100 are dual single-pole quad-throw analog switches (SP4T) suitable for use in analog or digital 4:1 multiplexer/demultiplexer applications. Each switch features four independent inputs/outputs (nY0, nY1, nY2 and nY3) and a common input/output (nZ). A digital enable input (E) and two digital select inputs (S0 & S1) are common to both switches. When \bar{E} is HIGH, the switches are turned off. The device features injection-current effect control. This allows signals at disabled analog input channels to exceed the supply voltage without affecting the signal of the enabled analog channel, eliminating the need for external diode/resistor networks typically used to keep the analog channel signals within the supply-voltage range. Inputs include clamp diodes. This enables the use of current limiting resistors to interface inputs to voltages in excess of V_{CC} .

This product has been qualified to the Automotive Electronics Council (AEC) standard Q100 (Grade 1) and is suitable for use in automotive applications.

2. Features and benefits

- Automotive product qualification in accordance with AEC-Q100 (Grade 1)
 - Specified from -40 °C to +85 °C and from -40 °C to +125 °C
- Injection-current cross coupling < 1 mV/mA
- Wide supply voltage range from 2.0 V to 6.0 V for 74HC4852-Q100
- Latch-up performance exceeds 100 mA per JESD 78 Class II level A
- Low ON-state resistance:
 - 400 Ω (typical) at $V_{CC} = 2.0$ V
 - 215 Ω (typical) at $V_{CC} = 3.0$ V
 - 120 Ω (typical) at $V_{CC} = 3.3$ V
 - 76 Ω (typical) at $V_{CC} = 4.5$ V
 - 59 Ω (typical) at $V_{CC} = 6.0$ V
- DHVQFN package with Side-Wettable Flanks enabling Automatic Optical Inspection (AOI) of solder joints
- ESD protection:
 - HBM: ANSI/ESDA/JEDEC JS-001 class 2 exceeds 2000 V
 - CDM: ANSI/ESDA/JEDEC JS-002 class C3 exceeds 1000 V

3. Applications

- Analog multiplexing and demultiplexing
- Digital multiplexing and demultiplexing
- Signal gating
- Automotive application

4. Ordering information

Table 1. Ordering information

Type number	Package			Version
	Temperature range	Name	Description	
74HC4852D-Q100 74HCT4852D-Q100	-40 °C to +125 °C	SO16	plastic small outline package; 16 leads; body width 3.9 mm	SOT109-1
74HC4852PW-Q100 74HCT4852PW-Q100	-40 °C to +125 °C	TSSOP16	plastic thin shrink small outline package; 16 leads; body width 4.4 mm	SOT403-1
74HC4852BQ-Q100 74HCT4852BQ-Q100	-40 °C to +125 °C	DHVQFN16	plastic dual in-line compatible thermal enhanced very thin quad flat package; no leads; 16 terminals; body 2.5 × 3.5 × 0.85 mm	SOT763-1

5. Functional diagram

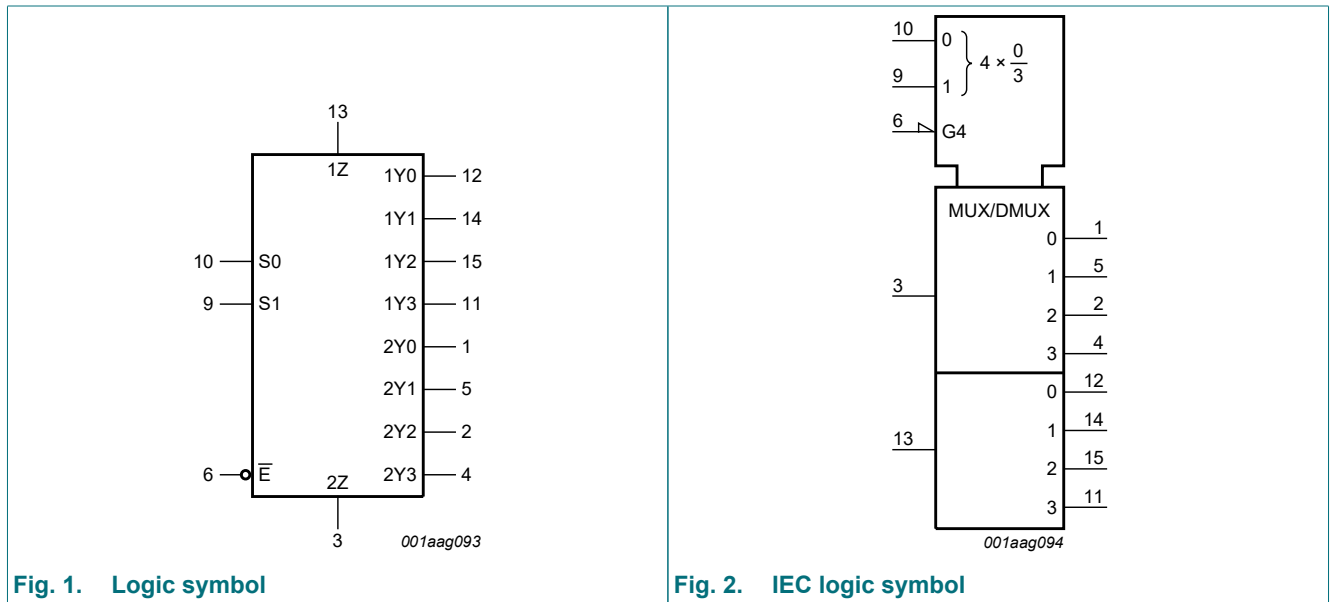

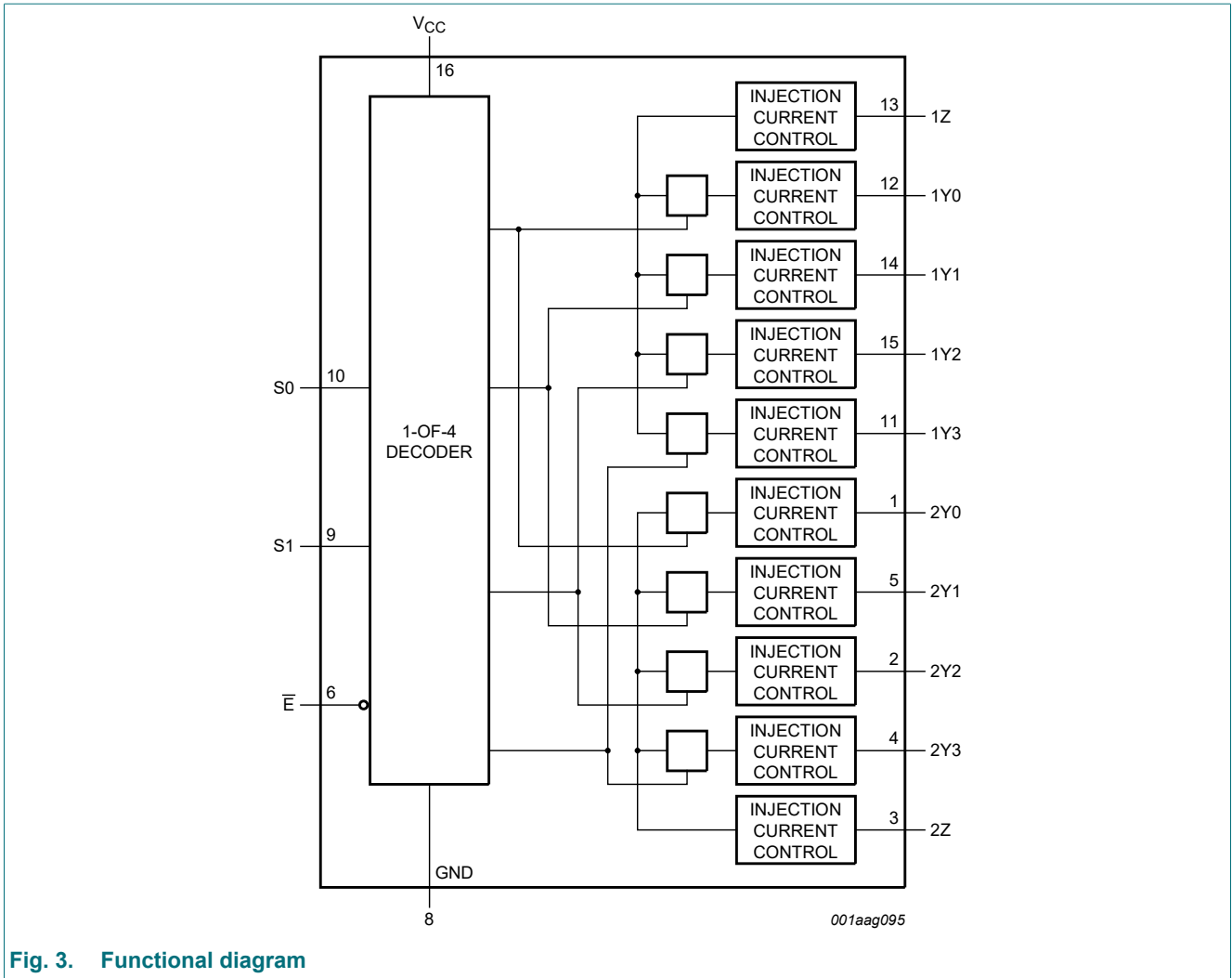
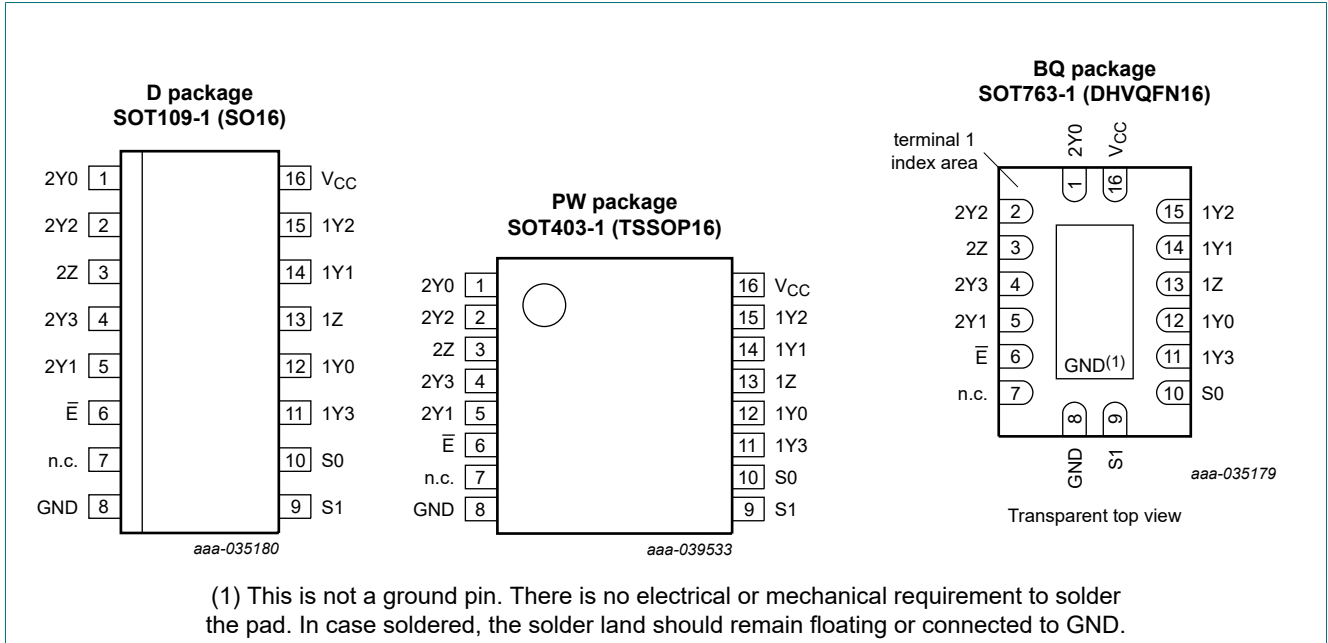

Fig. 3. Functional diagram

6. Pinning information

6.1. Pinning



6.2. Pin description

Table 2. Pin description

Symbol	Pin	Description
2Y0	1	independent input/output
2Y2	2	independent input/output
2Z	3	common input/output
2Y3	4	independent input/output
2Y1	5	independent input/output
E	6	enable input (active LOW)
n.c.	7	not connected
GND	8	ground (0 V)
S1	9	select input
S0	10	select input
1Y3	11	independent input/output
1Y0	12	independent input/output
1Z	13	common input/output
1Y1	14	independent input/output
1Y2	15	independent input/output
VCC	16	supply voltage

7. Functional description

Table 3. Function table

H = HIGH voltage level; L = LOW voltage level; X = don't care.

Input			Channel ON
E	S1	S0	
L	L	L	nY0 to nZ
L	L	H	nY1 to nZ
L	H	L	nY2 to nZ
L	H	H	nY3 to nZ
H	X	X	-

8. Limiting values

Table 4. Limiting values

In accordance with the Absolute Maximum Rating System (IEC 60134). Voltages are referenced to GND (ground = 0 V).

Symbol	Parameter	Conditions	Min	Max	Unit
V_{CC}	supply voltage		-0.5	+7.0	V
V_I	input voltage	[1]	-0.5	$V_{CC} + 0.5$	V
V_{SW}	switch voltage	[2]	-0.5	$V_{CC} + 0.5$	V
I_{IK}	input clamping current	$V_I < -0.5$ V or $V_I > V_{CC} + 0.5$ V	-	± 20	mA
I_{SK}	switch clamping current	$V_{SW} < -0.5$ V or $V_{SW} > V_{CC} + 0.5$ V	-	± 20	mA
I_{SW}	switch current	$V_{SW} > -0.5$ V or $V_{SW} < V_{CC} + 0.5$ V	-	± 25	mA
I_{CC}	supply current		-	50	mA
I_{GND}	ground current		-50	-	mA
T_{stg}	storage temperature		-65	+150	°C
P_{tot}	total power dissipation	$T_{amb} = -40$ °C to +125 °C [3]	-	500	mW

- [1] The minimum and maximum input voltage rating may be exceeded if the input clamping current rating is observed.
 [2] The minimum and maximum switch voltage rating may be exceeded if the switch clamping current rating is observed.
 [3] For SOT109-1 (SO16) package: P_{tot} derates linearly with 12.4 mW/K above 110 °C.
 For SOT403-1 (TSSOP16) package: P_{tot} derates linearly with 8.5 mW/K above 91 °C.
 For SOT763-1 (DHVQFN16) package: P_{tot} derates linearly with 11.2 mW/K above 106 °C.

9. Recommended operating conditions

Table 5. Recommended operating conditions

Symbol	Parameter	Conditions	74HC4852-Q100			74HCT4852-Q100			Unit
			Min	Typ	Max	Min	Typ	Max	
V_{CC}	supply voltage		2.0	-	6.0	4.5	5.0	5.5	V
V_I	input voltage		0	-	V_{CC}	0	-	V_{CC}	V
V_{SW}	switch voltage		0	-	V_{CC}	0	-	V_{CC}	V
T_{amb}	ambient temperature		-40	-	+125	-40	-	+125	°C
$\Delta t/\Delta V$	input transition rise and fall rate	$V_{CC} = 2.0\text{ V}$	-	6.0	1 000	-	-	-	ns/V
		$V_{CC} = 3.0\text{ V}$	-	6.0	800	-	-	-	ns/V
		$V_{CC} = 3.3\text{ V}$	-	6.0	800	-	-	-	ns/V
		$V_{CC} = 4.5\text{ V}$	-	6.0	500	-	6.0	500	ns/V
		$V_{CC} = 6.0\text{ V}$	-	6.0	400	-	-	-	ns/V

10. Static characteristics

Table 6. R_{ON} resistance

At recommended operating conditions; voltages are referenced to GND (ground 0 V); For test circuit see Fig. 6.

Symbol	Parameter	Conditions	25 °C			-40 °C to +85 °C		-40 °C to +125 °C		Unit
			Min	Typ	Max	Min	Max	Min	Max	
74HC4852-Q100										
$R_{ON(peak)}$	ON resistance (peak)	$V_I = V_{CC}$ to GND; $\bar{E} = V_{IL}$								
		$V_{CC} = 2.0\text{ V}; I_{SW} = 2\text{ mA}$	-	400	650	-	670	-	700	Ω
		$V_{CC} = 3.0\text{ V}; I_{SW} \leq 2\text{ mA}$	-	215	330	-	360	-	380	Ω
		$V_{CC} = 3.3\text{ V}; I_{SW} \leq 2\text{ mA}$	-	120	270	-	305	-	345	Ω
		$V_{CC} = 4.5\text{ V}; I_{SW} \leq 2\text{ mA}$	-	76	210	-	240	-	270	Ω
		$V_{CC} = 6.0\text{ V}; I_{SW} \leq 2\text{ mA}$	-	59	195	-	220	-	250	Ω
ΔR_{ON}	ON resistance mismatch between channels	$V_I = 0.5 \times V_{CC}; \bar{E} = V_{IL}$								
		$V_{CC} = 2.0\text{ V}; I_{SW} = 2\text{ mA}$	-	4	10	-	15	-	20	Ω
		$V_{CC} = 3.0\text{ V}; I_{SW} \leq 2\text{ mA}$	-	2	8	-	12	-	16	Ω
		$V_{CC} = 3.3\text{ V}; I_{SW} \leq 2\text{ mA}$	-	2	8	-	12	-	16	Ω
		$V_{CC} = 4.5\text{ V}; I_{SW} \leq 2\text{ mA}$	-	2	8	-	12	-	16	Ω
		$V_{CC} = 6.0\text{ V}; I_{SW} \leq 2\text{ mA}$	-	3	9	-	13	-	18	Ω
74HCT4852-Q100										
$R_{ON(peak)}$	ON resistance (peak)	$V_I = V_{CC}$ to GND; $\bar{E} = V_{IL}$								
		$V_{CC} = 4.5\text{ V}; I_{SW} \leq 2\text{ mA}$	-	76	210	-	240	-	270	Ω
ΔR_{ON}	ON resistance mismatch between channels	$V_I = 0.5 \times V_{CC}; \bar{E} = V_{IL}$								
		$V_{CC} = 4.5\text{ V}; I_{SW} \leq 2\text{ mA}$	-	2	8	-	12	-	16	Ω

Dual 4-channel analog multiplexer/demultiplexer with injection-current effect control

Table 7. Injection current coupling

At recommended operating conditions; voltages are referenced to GND (ground 0 V); For test circuit see Fig. 7.

Symbol	Parameter	Conditions	74HC4852-Q100			74HCT4852-Q100			Unit
			Min	Typ[1]	Max	Min	Typ[1]	Max	
T_{amb} = -40 °C to +125 °C									
ΔV_O	output voltage variation	$ I_{SW} \leq 1 \text{ mA}; R_S \leq 3.9 \text{ k}\Omega$ [2] [3]							
			$V_{CC} = 3.3 \text{ V}$	-	0.05	1	-	-	-
		$V_{CC} = 5.0 \text{ V}$	-	0.03	1	-	0.03	1	mV
		$ I_{SW} \leq 10 \text{ mA}; R_S \leq 3.9 \text{ k}\Omega$							
			$V_{CC} = 3.3 \text{ V}$	-	0.55	5	-	-	-
		$V_{CC} = 5.0 \text{ V}$	-	0.27	5	-	0.27	5	mV
		$ I_{SW} \leq 1 \text{ mA}; R_S \leq 20 \text{ k}\Omega$							
			$V_{CC} = 3.3 \text{ V}$	-	0.04	2	-	-	-
		$V_{CC} = 5.0 \text{ V}$	-	0.03	2	-	0.03	2	mV
		$ I_{SW} \leq 10 \text{ mA}; R_S \leq 20 \text{ k}\Omega$							
			$V_{CC} = 3.3 \text{ V}$	-	0.56	20	-	-	-
		$V_{CC} = 5.0 \text{ V}$	-	0.48	20	-	0.48	20	mV

[1] Typical values are measured at T_{amb} = 25 °C.

[2] ΔV_O here is the maximum variation of output voltage of an enabled analog channel when current is injected into any disabled channel.

[3] I_{SW} = total current injected into all disabled channels.

Table 8. Static characteristics

At recommended operating conditions; voltages are referenced to GND (ground 0 V).

Symbol	Parameter	Conditions	25 °C			-40 °C to +85 °C		-40 °C to +125 °C		Unit
			Min	Typ	Max	Min	Max	Min	Max	
74HC4852-Q100										
V_{IH}	HIGH-level input voltage	control inputs								
		$V_{CC} = 2.0 \text{ V}$	1.5	-	-	1.5	-	1.5	-	V
		$V_{CC} = 3.0 \text{ V}$	2.1	-	-	2.1	-	2.1	-	V
		$V_{CC} = 3.3 \text{ V}$	2.3	-	-	2.3	-	2.3	-	V
		$V_{CC} = 4.5 \text{ V}$	3.15	-	-	3.15	-	3.15	-	V
	$V_{CC} = 6.0 \text{ V}$	4.2	-	-	4.2	-	4.2	-	V	
V_{IL}	LOW-level input voltage	control inputs								
		$V_{CC} = 2.0 \text{ V}$	-	-	0.5	-	0.5	-	0.5	V
		$V_{CC} = 3.0 \text{ V}$	-	-	0.9	-	0.9	-	0.9	V
		$V_{CC} = 3.3 \text{ V}$	-	-	1.0	-	1.0	-	1.0	V
		$V_{CC} = 4.5 \text{ V}$	-	-	1.35	-	1.35	-	1.35	V
	$V_{CC} = 6.0 \text{ V}$	-	-	1.8	-	1.8	-	1.8	V	
I_I	input leakage current	control inputs; $V_I = \text{GND}$ or V_{CC}								
		$V_{CC} = 6.0 \text{ V}$	-	-	±0.1	-	±0.1	-	±1.0	µA
$I_{S(OFF)}$	OFF-state leakage current	$\bar{E} = V_{IH}; V_I = \text{GND}$ or $V_{CC}; V_O = V_{CC}$ or $\text{GND}; V_{CC} = 6.0 \text{ V};$ see Fig. 4								
		nYn; per channel	-	-	±0.1	-	±0.5	-	±1.0	µA
		nZ; all channels	-	-	±0.2	-	±2.0	-	±4.0	µA

Dual 4-channel analog multiplexer/demultiplexer with injection-current effect control

Symbol	Parameter	Conditions	25 °C			-40 °C to +85 °C		-40 °C to +125 °C		Unit
			Min	Typ	Max	Min	Max	Min	Max	
$I_{S(ON)}$	ON-state leakage current	$\bar{E} = V_{IL}; V_I = \text{GND or } V_{CC}; V_O = V_{CC} \text{ or GND}; V_{CC} = 6.0 \text{ V};$ see Fig. 5	-	-	± 0.1	-	± 0.5	-	± 1.0	μA
I_{CC}	supply current	$V_I = \text{GND or } V_{CC}$								
		$V_{CC} = 6.0 \text{ V}$	-	-	2.0	-	5.0	-	20.0	μA
C_I	input capacitance	S0, S1, S2 and \bar{E}	-	2	10	-	10	-	10	pF
C_{sw}	switch capacitance	nZ; OFF-state	-	15	40	-	40	-	40	pF
		nYn; OFF-state	-	3	15	-	15	-	15	pF
74HCT4852-Q100										
V_{IH}	HIGH-level input voltage	control inputs								
		$V_{CC} = 4.5 \text{ V to } 5.5 \text{ V}$	2.0	-	-	2.0	-	2.0	-	V
V_{IL}	LOW-level input voltage	control inputs								
		$V_{CC} = 4.5 \text{ V to } 5.5 \text{ V}$	-	-	0.8	-	0.8	-	0.8	V
I_I	input leakage current	control inputs; $V_I = \text{GND or } V_{CC}$								
		$V_{CC} = 5.5 \text{ V}$	-	-	± 0.1	-	± 0.1	-	± 1.0	μA
$I_{S(OFF)}$	OFF-state leakage current	$\bar{E} = V_{IH}; V_I = \text{GND or } V_{CC}; V_O = V_{CC} \text{ or GND}; V_{CC} = 5.5 \text{ V};$ see Fig. 4								
		per channel	-	-	± 0.1	-	± 0.5	-	± 1.0	μA
		all channels	-	-	± 0.2	-	± 2.0	-	± 4.0	μA
$I_{S(ON)}$	ON-state leakage current	$\bar{E} = V_{IL}; V_I = \text{GND or } V_{CC}; V_O = V_{CC} \text{ or GND}; V_{CC} = 5.5 \text{ V};$ see Fig. 5	-	-	± 0.1	-	± 0.5	-	± 1.0	μA
I_{CC}	supply current	$V_I = \text{GND or } V_{CC}$								
		$V_{CC} = 5.5 \text{ V}$	-	-	2.0	-	5.0	-	20.0	μA
ΔI_{CC}	additional supply current	control inputs; $V_I = V_{CC} - 2.1 \text{ V};$ other inputs at $V_{CC} \text{ or GND}; V_{CC} = 4.5 \text{ V to } 5.5 \text{ V}; I_O = 0 \text{ A}$	-	-	300	-	370	-	370	μA
C_I	input capacitance	S0, S1, S2 and \bar{E}	-	2	10	-	10	-	10	pF
C_{sw}	switch capacitance	nZ; OFF-state	-	9	40	-	40	-	40	pF
		nYn; OFF-state	-	3	15	-	15	-	15	pF

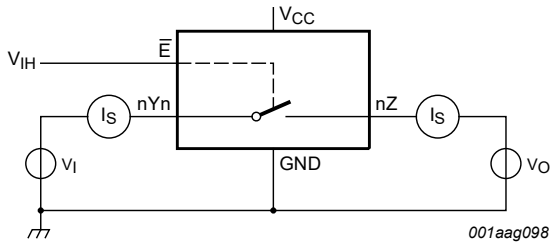

Fig. 4. Test circuit for measuring OFF-state leakage current

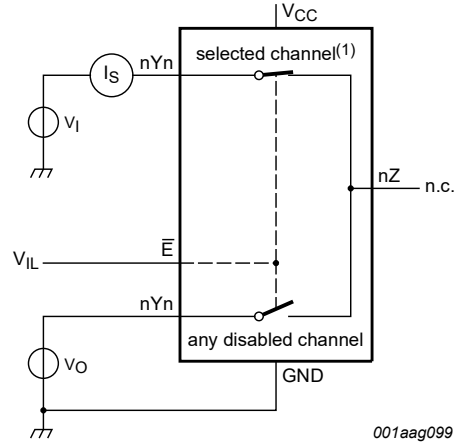

Fig. 5. Test circuit for measuring ON-state leakage current

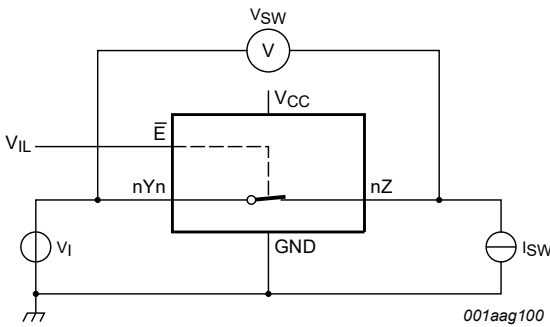

Fig. 6. Test circuit for measuring ON resistance

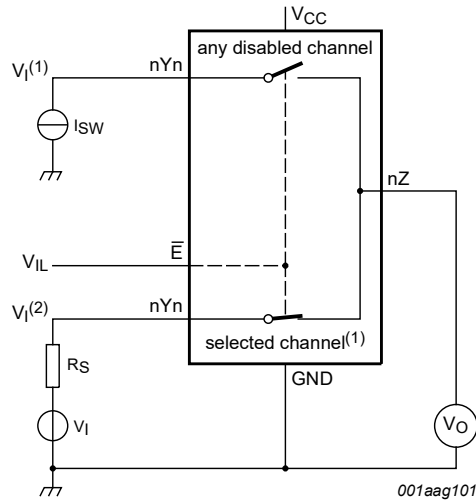

Fig. 7. Test circuit for injection current coupling

11. Dynamic characteristics

Table 9. Dynamic characteristics

At recommended operating conditions; voltages are referenced to GND (ground 0 V); for test circuit see Fig. 12.

Symbol	Parameter	Conditions	25 °C			-40 °C to +85 °C		-40 °C to +125 °C		Unit
			Min	Typ	Max	Min	Max	Min	Max	
74HC4852-Q100										
t _{pd}	propagation delay	nZ, nYn to nYn, nZ; see Fig. 8 [1]								
		V _{CC} = 2.0 V	2.2	9.3	33	2.2	34	2.2	35	ns
		V _{CC} = 3.0 V	2.2	4.9	16.5	1.9	18	1.9	19.5	ns
		V _{CC} = 3.3 V	2.0	4.4	15.0	1.6	16.5	1.6	18.5	ns
		V _{CC} = 4.5 V	1.6	3.2	11.6	1.1	12.5	1.1	13.5	ns
		V _{CC} = 6.0 V	1.5	2.5	10.2	0.9	11	0.9	12	ns
		Sn to nZ, nYn; see Fig. 9 [1]								
		V _{CC} = 2.0 V	7.7	16.8	38	6.3	40	6.3	42	ns
		V _{CC} = 3.0 V	4.9	8.8	20	3.9	21.5	3.9	23	ns
		V _{CC} = 3.3 V	4.4	7.9	17.5	3.4	19	3.4	22	ns
		V _{CC} = 4.5 V	3.2	5.8	14	2.3	15	2.3	17	ns
V _{CC} = 6.0 V	2.4	4.8	12.6	1.6	14.5	1.6	16.5	ns		
t _{en}	enable time	\bar{E} to nZ, nYn; see Fig. 10 [2]								
		V _{CC} = 2.0 V	10.5	20.5	47.5	8.5	52.5	8.5	57.5	ns
		V _{CC} = 3.0 V	6.2	10.6	45	5.2	50	5.2	55	ns
		V _{CC} = 3.3 V	5.6	9.4	42.5	4.6	47.5	4.6	52.5	ns
		V _{CC} = 4.5 V	4.2	6.9	40	3	45	3	50	ns
		V _{CC} = 6.0 V	3.2	5.6	39	2.2	40	2.2	40	ns
t _{dis}	disable time	\bar{E} to nZ, nYn; see Fig. 10 [3]								
		V _{CC} = 2.0 V	39.5	75.4	100	39.3	105	39	115	ns
		V _{CC} = 3.0 V	35.2	69.5	90	35.5	100	35	110	ns
		V _{CC} = 3.3 V	34.6	68.1	85	34.6	95	34.5	105	ns
		V _{CC} = 4.5 V	28.5	63	80	28.2	90	28	100	ns
		V _{CC} = 6.0 V	14.4	57.9	78	13.5	80	13.0	80	ns
C _{PD}	power dissipation capacitance	per channel; see Fig. 11 [4]								
		V _{CC} = 3.3 V	-	42	-	-	-	-	-	pF
		V _{CC} = 5.0 V	-	47	-	-	-	-	-	pF

Dual 4-channel analog multiplexer/demultiplexer with injection-current effect control

Symbol	Parameter	Conditions	25 °C			-40 °C to +85 °C		-40 °C to +125 °C		Unit
			Min	Typ	Max	Min	Max	Min	Max	
74HCT4852-Q100										
t _{pd}	propagation delay	nZ, nYn to nYn, nZ; see Fig. 8 [1]								
		V _{CC} = 4.5 V	1.6	3.5	11.5	1.1	12.5	1.1	13.5	ns
		Sn to nZ, nYn; see Fig. 9 [1]								
		V _{CC} = 4.5 V	3.2	7.6	13	2.3	15	1.6	17	ns
t _{en}	enable time	\bar{E} to nZ, nYn; see Fig. 10 [2]								
		V _{CC} = 4.5 V	4.2	8.3	25	3.0	30	3.0	35	ns
t _{dis}	disable time	\bar{E} to nZ, nYn; see Fig. 10 [3]								
		V _{CC} = 4.5 V	28.5	61.8	80	28.2	90	28.0	100	ns
C _{PD}	power dissipation capacitance	per channel; see Fig. 11 [4]								
		V _{CC} = 5.0 V	-	47	-	-	-	-	-	pF

- [1] t_{pd} is the same as t_{PLH} and t_{PHL}.
- [2] t_{en} is the same as t_{PZH} and t_{PZL}.
- [3] t_{dis} is the same as t_{PLZ} and t_{PHZ}.
- [4] C_{PD} is used to determine the dynamic power dissipation (P_D in μW):
 $P_D = C_{PD} \times V_{CC}^2 \times f_i + \sum\{(C_L + C_{sw}) \times V_{CC}^2 \times f_o\}$ where:
 f_i = input frequency in MHz;
 f_o = output frequency in MHz;
 $\sum\{(C_L + C_{sw}) \times V_{CC}^2 \times f_o\}$ = sum of outputs;
 C_L = output load capacitance in pF;
 C_{sw} = switch capacitance in pF;
 V_{CC} = supply voltage in V.

11.1. Waveforms and test circuit

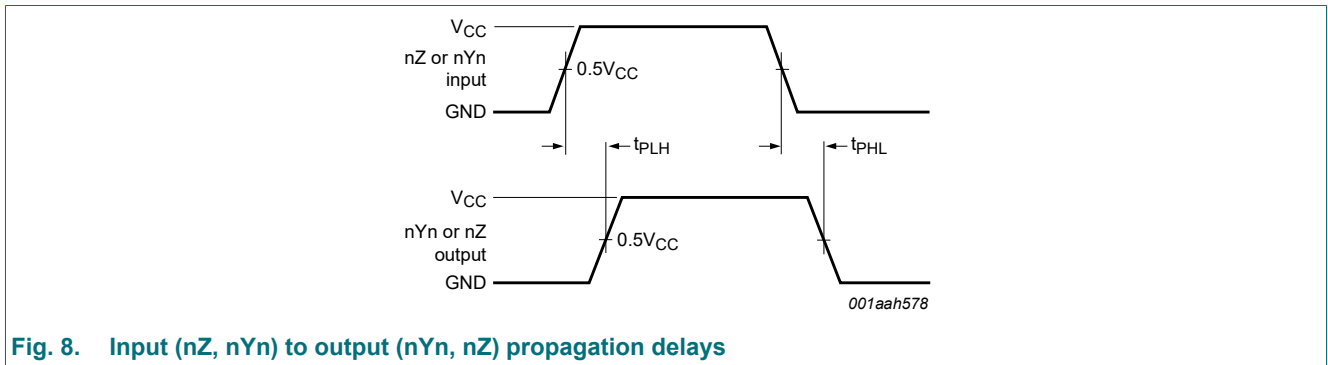
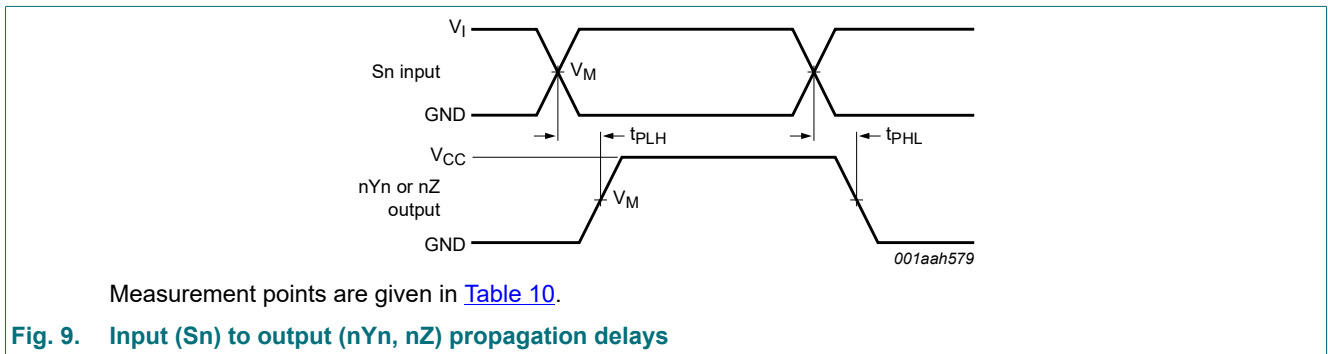

Fig. 8. Input (nZ, nYn) to output (nYn, nZ) propagation delays



Measurement points are given in Table 10.

Fig. 9. Input (Sn) to output (nYn, nZ) propagation delays

Dual 4-channel analog multiplexer/demultiplexer with injection-current effect control

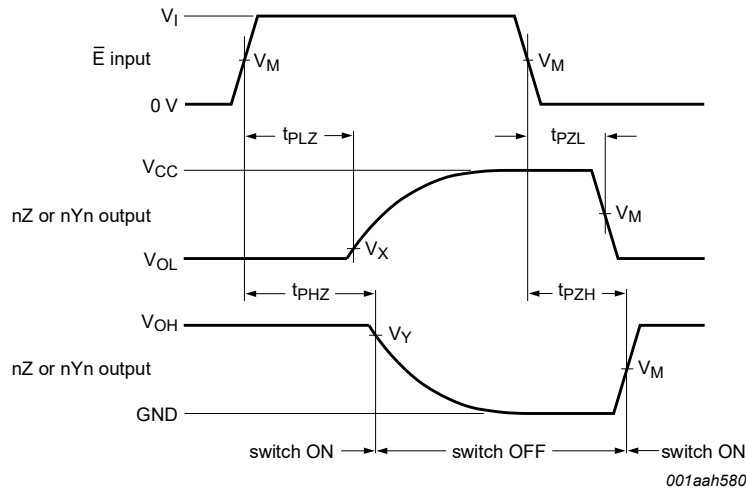

Measurement points are shown in [Table 10](#).
 Logic levels: V_{OL} and V_{OH} are typical output voltage levels that occur with the output load.

Fig. 10. Enable and disable times

Table 10. Measurement points

Type	Input		Output		
	V_M	V_I	V_M	V_X	V_Y
74HC4852-Q100	$0.5V_{CC}$	V_{CC}	$0.5V_{CC}$	$V_{OL} + 0.1(V_{CC} - V_{OL})$	$0.9V_{OH}$
74HCT4852-Q100	1.3 V	3.0 V	$0.5V_{CC}$	$V_{OL} + 0.1(V_{CC} - V_{OL})$	$0.9V_{OH}$

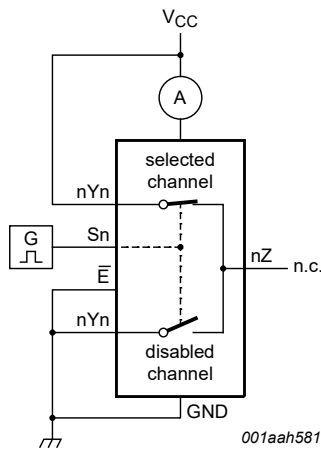

Fig. 11. Test circuit for measuring power dissipation capacitance

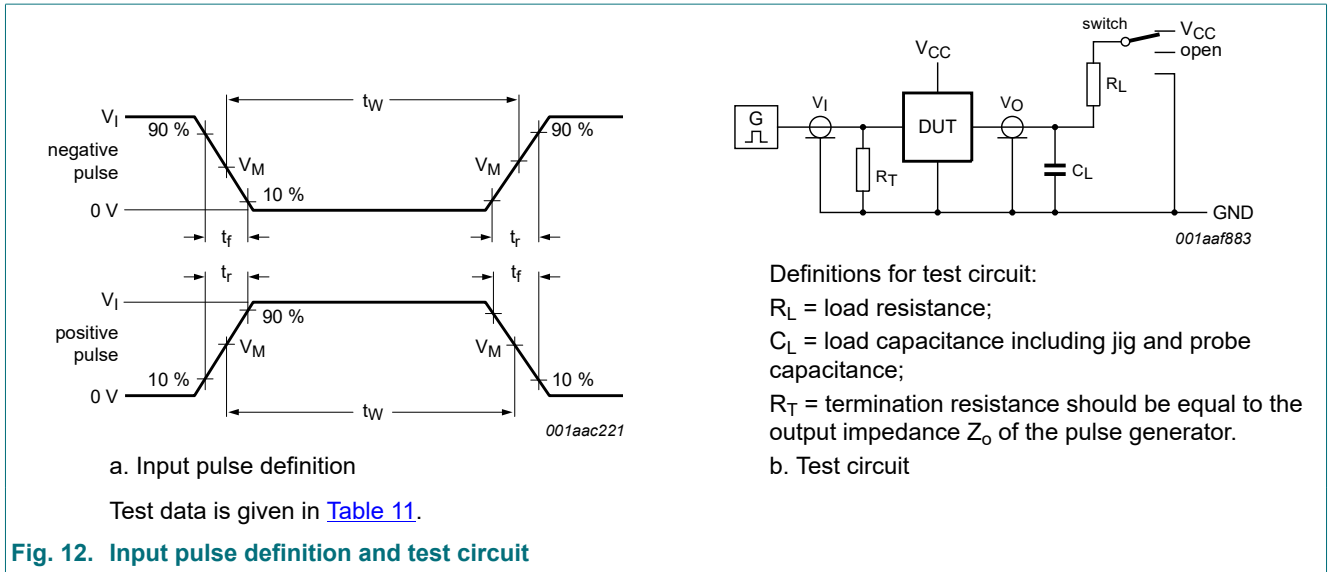

Table 11. Test data

Test	Input			Output		S1 position
	Control \bar{E} , Sn	Switch nYn (nZ)	t_r , t_f	Switch nZ (nYn)		
	V_I [1]	V_I		C_L	R_L	
t_{PHL} , t_{PLH}	V_{CC}	V_{CC}	6 ns	50 pF	-	open
t_{PHZ} , t_{PZH}	V_{CC}	V_{CC}	6 ns	50 pF	10 k Ω	GND
t_{PLZ} , t_{PZL}	V_{CC}	V_{CC}	6 ns	50 pF	10 k Ω	V_{CC}
C_{PD}	V_{CC}	V_{CC}	6 ns	0 pF	-	open

[1] For 74HCT4852-Q100: input voltage $V_I = 3.0$ V.

12. Package outline

SO16: plastic small outline package; 16 leads; body width 3.9 mm

SOT109-1



Fig. 13. Package outline SOT109-1 (SO16)

TSSOP16: plastic thin shrink small outline package; 16 leads; body width 4.4 mm

SOT403-1



Fig. 14. Package outline SOT403-1 (TSSOP16)

DHVQFN16: plastic dual in-line compatible thermal enhanced very thin quad flat package; no leads; 16 terminals; body 2.5 x 3.5 x 0.85 mm

SOT763-1



Fig. 15. Package outline SOT763-1 (DHVQFN16)

13. Abbreviations

Table 12. Abbreviations

Acronym	Description
CDM	Charged Device Model
CMOS	Complementary Metal Oxide Semiconductor
DUT	Device Under Test
ESD	ElectroStatic Discharge
HBM	Human Body Model

14. Revision history

Table 13. Revision history

Document ID	Release date	Data sheet status	Change notice	Supersedes
74HC_HCT4852_Q100 v.3	20240416	Product data sheet	-	74HC_HCT4852_Q100 v.2
Modifications:	<ul style="list-style-type: none"> Section 2: ESD specification updated according to the latest JEDEC standard. Fig. 13, Fig. 14: Aligned SO and TSSOP package outline drawings to JEDEC MS-012 and MO-153 			
74HC_HCT4852_Q100 v.2	20200428	Product data sheet	-	74HC4852_Q100 v.1
Modifications:	<ul style="list-style-type: none"> Section 1: updated. Section 2 updated. Section 8: Derating values for P_{tot} total power dissipation have been updated. 			
74HC4852_Q100 v.1	20120712	Product data sheet	-	-

15. Legal information

Data sheet status

Document status [1][2]	Product status [3]	Definition
Objective [short] data sheet	Development	This document contains data from the objective specification for product development.
Preliminary [short] data sheet	Qualification	This document contains data from the preliminary specification.
Product [short] data sheet	Production	This document contains the product specification.

- [1] Please consult the most recently issued document before initiating or completing a design.
- [2] The term 'short data sheet' is explained in section "Definitions".
- [3] The product status of device(s) described in this document may have changed since this document was published and may differ in case of multiple devices. The latest product status information is available on the internet at <https://www.nexperia.com>.

Definitions

Draft — The document is a draft version only. The content is still under internal review and subject to formal approval, which may result in modifications or additions. Nexperia does not give any representations or warranties as to the accuracy or completeness of information included herein and shall have no liability for the consequences of use of such information.

Short data sheet — A short data sheet is an extract from a full data sheet with the same product type number(s) and title. A short data sheet is intended for quick reference only and should not be relied upon to contain detailed and full information. For detailed and full information see the relevant full data sheet, which is available on request via the local Nexperia sales office. In case of any inconsistency or conflict with the short data sheet, the full data sheet shall prevail.

Product specification — The information and data provided in a Product data sheet shall define the specification of the product as agreed between Nexperia and its customer, unless Nexperia and customer have explicitly agreed otherwise in writing. In no event however, shall an agreement be valid in which the Nexperia product is deemed to offer functions and qualities beyond those described in the Product data sheet.

Disclaimers

Limited warranty and liability — Information in this document is believed to be accurate and reliable. However, Nexperia does not give any representations or warranties, expressed or implied, as to the accuracy or completeness of such information and shall have no liability for the consequences of use of such information. Nexperia takes no responsibility for the content in this document if provided by an information source outside of Nexperia.

In no event shall Nexperia be liable for any indirect, incidental, punitive, special or consequential damages (including - without limitation - lost profits, lost savings, business interruption, costs related to the removal or replacement of any products or rework charges) whether or not such damages are based on tort (including negligence), warranty, breach of contract or any other legal theory.

Notwithstanding any damages that customer might incur for any reason whatsoever, Nexperia's aggregate and cumulative liability towards customer for the products described herein shall be limited in accordance with the Terms and conditions of commercial sale of Nexperia.

Right to make changes — Nexperia reserves the right to make changes to information published in this document, including without limitation specifications and product descriptions, at any time and without notice. This document supersedes and replaces all information supplied prior to the publication hereof.

Suitability for use in automotive applications — This Nexperia product has been qualified for use in automotive applications. Unless otherwise agreed in writing, the product is not designed, authorized or warranted to be suitable for use in life support, life-critical or safety-critical systems or

equipment, nor in applications where failure or malfunction of an Nexperia product can reasonably be expected to result in personal injury, death or severe property or environmental damage. Nexperia and its suppliers accept no liability for inclusion and/or use of Nexperia products in such equipment or applications and therefore such inclusion and/or use is at the customer's own risk.

Quick reference data — The Quick reference data is an extract of the product data given in the Limiting values and Characteristics sections of this document, and as such is not complete, exhaustive or legally binding.

Applications — Applications that are described herein for any of these products are for illustrative purposes only. Nexperia makes no representation or warranty that such applications will be suitable for the specified use without further testing or modification.

Customers are responsible for the design and operation of their applications and products using Nexperia products, and Nexperia accepts no liability for any assistance with applications or customer product design. It is customer's sole responsibility to determine whether the Nexperia product is suitable and fit for the customer's applications and products planned, as well as for the planned application and use of customer's third party customer(s). Customers should provide appropriate design and operating safeguards to minimize the risks associated with their applications and products.

Nexperia does not accept any liability related to any default, damage, costs or problem which is based on any weakness or default in the customer's applications or products, or the application or use by customer's third party customer(s). Customer is responsible for doing all necessary testing for the customer's applications and products using Nexperia products in order to avoid a default of the applications and the products or of the application or use by customer's third party customer(s). Nexperia does not accept any liability in this respect.

Limiting values — Stress above one or more limiting values (as defined in the Absolute Maximum Ratings System of IEC 60134) will cause permanent damage to the device. Limiting values are stress ratings only and (proper) operation of the device at these or any other conditions above those given in the Recommended operating conditions section (if present) or the Characteristics sections of this document is not warranted. Constant or repeated exposure to limiting values will permanently and irreversibly affect the quality and reliability of the device.

Terms and conditions of commercial sale — Nexperia products are sold subject to the general terms and conditions of commercial sale, as published at <http://www.nexperia.com/profile/terms>, unless otherwise agreed in a valid written individual agreement. In case an individual agreement is concluded only the terms and conditions of the respective agreement shall apply. Nexperia hereby expressly objects to applying the customer's general terms and conditions with regard to the purchase of Nexperia products by customer.

No offer to sell or license — Nothing in this document may be interpreted or construed as an offer to sell products that is open for acceptance or the grant, conveyance or implication of any license under any copyrights, patents or other industrial or intellectual property rights.

Export control — This document as well as the item(s) described herein may be subject to export control regulations. Export might require a prior authorization from competent authorities.

Translations — A non-English (translated) version of a document is for reference only. The English version shall prevail in case of any discrepancy between the translated and English versions.

Trademarks

Notice: All referenced brands, product names, service names and trademarks are the property of their respective owners.

Contents

1. General description	1
2. Features and benefits	1
3. Applications	1
4. Ordering information	2
5. Functional diagram	2
6. Pinning information	4
6.1. Pinning.....	4
6.2. Pin description.....	4
7. Functional description	5
8. Limiting values	5
9. Recommended operating conditions	6
10. Static characteristics	6
11. Dynamic characteristics	10
11.1. Waveforms and test circuit.....	11
12. Package outline	14
13. Abbreviations	17
14. Revision history	17
15. Legal information	18

© Nexperia B.V. 2024. All rights reserved

For more information, please visit: <http://www.nexperia.com>

For sales office addresses, please send an email to: salesaddresses@nexperia.com

Date of release: 16 April 2024

Looking for pricing, stock, or lifecycle information?

Click below to explore more details on WIN SOURCE:

- [View 74HCT4852PW-Q100118 on WIN SOURCE](#)
- [NXP / Nexperia Information](#)

Optimize Your Supply Chain with WIN SOURCE Solutions

- ✓ Global Sourcing Solution
- ✓ Obsolete Management
- ✓ Cost Control Management
- ✓ Shortage Management
- ✓ Alternative Solution
- ✓ Excess Inventory Management