

FEATURES:

- 0.5 MICRON CMOS Technology
- Typical $t_{sk(o)}$ (Output Skew) < 250ps
- ESD > 2000V per MIL-STD-883, Method 3015; > 200V using machine model (C = 200pF, R = 0)
- $V_{cc} = 3.3V \pm 0.3V$, Normal Range
- $V_{cc} = 2.7V$ to $3.6V$, Extended Range
- $V_{cc} = 2.5V \pm 0.2V$
- CMOS power levels (0.4 μ W typ. static)
- Rail-to-Rail output swing for increased noise margin
- Available in TSSOP and TVSOP packages

DRIVE FEATURES:

- Balanced Output Drivers: $\pm 18mA$
- Low switching noise

APPLICATIONS:

- SDRAM Modules
- PC Motherboards
- Workstations

DESCRIPTION:

This 18-bit universal bus driver is built using advanced dual metal CMOS technology. Data flow from A to Y is controlled by the output-enable (\overline{OE}) input. The device operates in the transparent mode when the latch-enable (LE) input is high. The A data is latched if the clock (CLK) input is held at a high or low logic level. If LE is low, the A data is stored in the latch flip-flop on the low-to-high transition of CLK. When \overline{OE} is high, the outputs are in the high-impedance state.

The ALVCF162835A has series resistors in the device output structure which will reduce switching noise in 128MB and 256MB SDRAM modules. Designed with a drive capability of $\pm 18mA$, the ALVCF162835A is a mid-way drive between the ALVC162835 ($\pm 12mA$) and ALVC16835 ($\pm 24mA$).

The ALVCF162835A is a faster version of the ALVCF162835 or ALVC162835. It is suitable for PC133 applications and particularly SDRAM Modules clocked at 133 MHz.

FUNCTIONAL BLOCK DIAGRAM

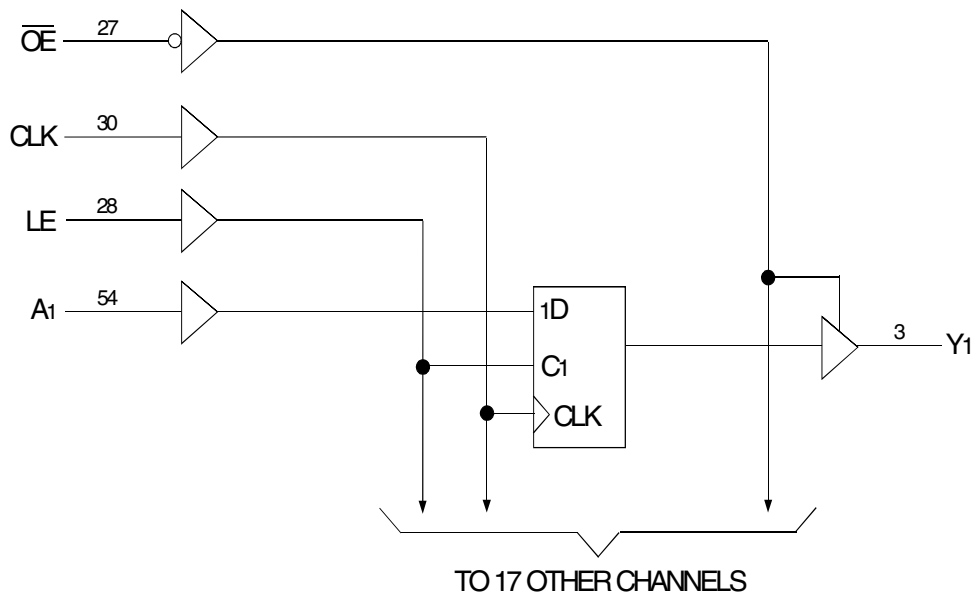

PIN CONFIGURATION

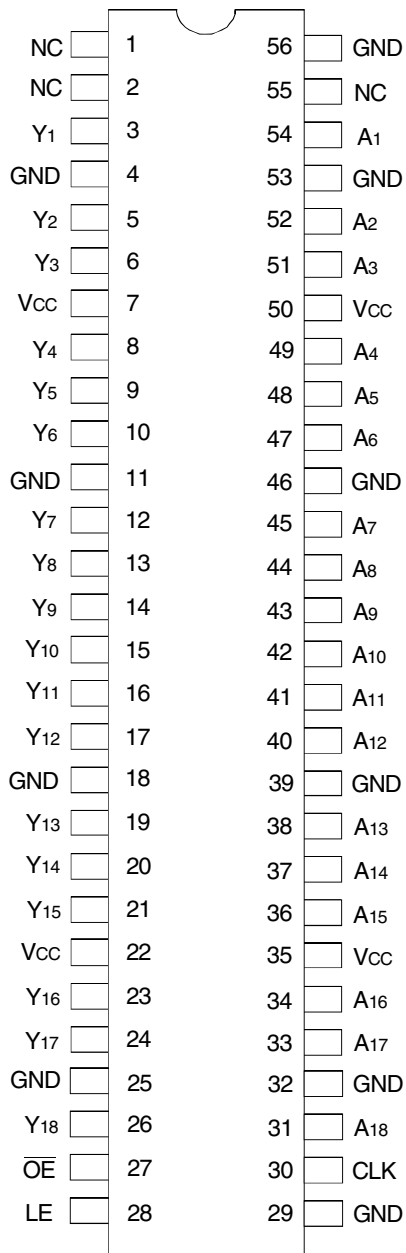

TSSOP/TVSOP
TOP VIEW

PIN DESCRIPTION

Pin Names	Description
\overline{OE}	3-State Output Enable Inputs (Active LOW)
CLK	Register Input Clock
LE	Latch Enable (Transparent HIGH)
Ax	Data Inputs
Yx	3-State Outputs

ABSOLUTE MAXIMUM RATINGS⁽¹⁾

Symbol	Description	Max	Unit
VTERM ⁽²⁾	Terminal Voltage with Respect to GND	-0.5 to +4.6	V
VTERM ⁽³⁾	Terminal Voltage with Respect to GND	-0.5 to Vcc+0.5	V
TSTG	Storage Temperature	-65 to +150	°C
IOUT	DC Output Current	-50 to +50	mA
I _{IK}	Continuous Clamp Current, V _I < 0 or V _I > Vcc	±50	mA
I _{OK}	Continuous Clamp Current, V _O < 0	-50	mA
I _{CC} I _{SS}	Continuous Current through each Vcc or GND	±100	mA

NOTES:

- Stresses greater than those listed under ABSOLUTE MAXIMUM RATINGS may cause permanent damage to the device. This is a stress rating only and functional operation of the device at these or any other conditions above those indicated in the operational sections of this specification is not implied. Exposure to absolute maximum rating conditions for extended periods may affect reliability.
- Vcc terminals.
- All terminals except Vcc.

CAPACITANCE (T_A = +25°C, F = 1.0MHz)

Symbol	Parameter ⁽¹⁾	Conditions	Min.	Typ.	Max.	Unit
C _{IN}	Input Capacitance	V _{IN} = 0V	4	5	6	pF
C _{OUT}	Output Capacitance	V _{OUT} = 0V	—	7	9	pF
C _{OUT}	I/O Port Capacitance	V _{IN} = 0V	—	7	9	pF

NOTE:

- As applicable to the device type.

FUNCTION TABLE⁽¹⁾

Inputs				Outputs
\overline{OE}	LE	CLK	Ax	Yx
H	X	X	X	Z
L	H	X	L	L
L	H	X	H	H
L	L	↑	L	L
L	L	↑	H	H
L	L	H	X	Y ₀ ⁽²⁾
L	L	L	X	Y ₀ ⁽³⁾

NOTES:

- H = HIGH Voltage Level
L = LOW Voltage Level
X = Don't Care
Z = High-Impedance
↑ = LOW-to-HIGH Transition
- Output level before indicated steady-state input conditions were established, provided that CLK is HIGH before LE went LOW.
- Output level before the indicated steady-state input conditions were established.

DC ELECTRICAL CHARACTERISTICS OVER OPERATING RANGE

Following Conditions Apply Unless Otherwise Specified:

Operating Condition: $T_A = -40^{\circ}\text{C}$ to $+85^{\circ}\text{C}$

Symbol	Parameter	Test Conditions		Min.	Typ. ⁽¹⁾	Max.	Unit
V _{IH}	Input HIGH Voltage Level	V _{CC} = 2.3V to 2.7V		1.7	—	—	V
		V _{CC} = 2.7V to 3.6V		2	—	—	
V _{IL}	Input LOW Voltage Level	V _{CC} = 2.3V to 2.7V		—	—	0.7	V
		V _{CC} = 2.7V to 3.6V		—	—	0.8	
I _{IH}	Input HIGH Current	V _{CC} = 3.6V	V _I = V _{CC}	—	—	±5	μA
I _{IL}	Input LOW Current	V _{CC} = 3.6V	V _I = GND	—	—	±5	μA
I _{OZH} I _{OZL}	High Impedance Output Current (3-State Output pins)	V _{CC} = 3.6V		—	—	±10	μA
		V _O = GND		—	—	±10	
V _{IK}	Clamp Diode Voltage	V _{CC} = 2.3V, I _{IN} = -18mA		—	-0.7	-1.2	V
V _H	Input Hysteresis	V _{CC} = 3.3V		—	100	—	mV
I _{CC1} I _{CC2} I _{CC3}	Quiescent Power Supply Current	V _{CC} = 3.6V V _{IN} = GND or V _{CC}		—	0.1	40	μA
ΔI _{CC}	Quiescent Power Supply Current Variation	One input at V _{CC} - 0.6V, other inputs at V _{CC} or GND		—	—	750	μA

NOTE:

1. Typical values are at V_{CC} = 3.3V, +25°C ambient.

OUTPUT DRIVE CHARACTERISTICS

Symbol	Parameter	Test Conditions ⁽¹⁾		Min.	Max.	Unit
V _{OH}	Output HIGH Voltage	V _{CC} = 2.3V to 3.6V	I _{OH} = -0.1mA	V _{CC} - 0.2	—	V
		V _{CC} = 2.3V	I _{OH} = -6mA	1.9	—	
			I _{OH} = -8mA	1.7	—	
		V _{CC} = 2.7V	I _{OH} = -6mA	2.2	—	
			I _{OH} = -12mA	2	—	
		V _{CC} = 3V	I _{OH} = -8mA	2.4	—	
I _{OH} = -18mA	2		—			
V _{OL}	Output LOW Voltage	V _{CC} = 2.3V to 3.6V	I _{OL} = 0.1mA	—	0.2	V
		V _{CC} = 2.3V	I _{OL} = 6mA	—	0.4	
			I _{OL} = 8mA	—	0.55	
		V _{CC} = 2.7V	I _{OL} = 6mA	—	0.4	
			I _{OL} = 12mA	—	0.6	
		V _{CC} = 3V	I _{OL} = 8mA	—	0.55	
I _{OL} = 18mA	—		0.8			

NOTE:

1. V_{IH} and V_{IL} must be within the min. or max. range shown in the DC ELECTRICAL CHARACTERISTICS OVER OPERATING RANGE table for the appropriate V_{CC} range.
T_A = -40°C to +85°C.

OPERATING CHARACTERISTICS, $T_A = 25^\circ\text{C}$

Symbol	Parameter	Test Conditions	$V_{CC} = 2.5V \pm 0.2V$	$V_{CC} = 3.3V \pm 0.3V$	Unit
			Typical	Typical	
CPD	Power Dissipation Capacitance Outputs enabled	$C_L = 0\text{pF}$, $f = 10\text{MHz}$	30	35	pF
CPD	Power Dissipation Capacitance Outputs disabled		12.5	14	

SWITCHING CHARACTERISTICS⁽¹⁾

Symbol	Parameter	$V_{CC} = 2.5V \pm 0.2V$		$V_{CC} = 2.7V$		$V_{CC} = 3.3V \pm 0.3V$		Unit
		Min.	Max.	Min.	Max.	Min.	Max.	
f_{CLOCK}		150	—	150	—	150	—	MHz
t_{PLH} t_{PHL}	Propagation Delay Ax to Yx	1	4	—	4.6	1	3.5	ns
t_{PLH} t_{PHL}	Propagation Delay LE to Yx	1.3	5.5	—	5.4	1.3	4.6	ns
t_{PLH} t_{PHL}	Propagation Delay CLK to Yx	1.4	5.9	—	5.6	1.4	3.5	ns
t_{PZH} t_{PZL}	Output Enable Time $\overline{\text{OE}}$ to Yx	1.4	5.9	—	6	1.1	5	ns
t_{PHZ} t_{PLZ}	Output Disable Time $\overline{\text{OE}}$ to Yx	1	4.7	—	4.6	1.3	4.2	ns
t_w	Pulse Duration, LE HIGH	3.3	—	3.3	—	3.3	—	ns
t_w	Pulse Duration, CLK HIGH or LOW	3.3	—	3.3	—	3.3	—	ns
t_{SU}	Set-up Time, data before $\text{CLK}\uparrow$	1.8	—	1.5	—	1	—	ns
t_{SU}	Set-up Time, data before $\text{LE}\downarrow$, CLK HIGH	1.9	—	1.6	—	1.5	—	ns
t_{SU}	Set-up Time, data before $\text{LE}\downarrow$, CLK LOW	1.3	—	1.1	—	1	—	ns
t_{H}	Hold Time, data after $\text{CLK}\uparrow$	0.6	—	0.6	—	0.6	—	ns
t_{H}	Hold Time, data after $\text{LE}\downarrow$, CLK HIGH or LOW	1.4	—	1.7	—	1.4	—	ns
$t_{\text{SK(O)}}$	Output Skew ⁽²⁾	—	—	—	—	—	500	ps

NOTES:

- See TEST CIRCUITS AND WAVEFORMS. $T_A = -40^\circ\text{C}$ to $+85^\circ\text{C}$.
- Skew between any two outputs of the same package and switching in the same direction.

SWITCHING CHARACTERISTICS FROM 0°C TO 65°C , $C_L = 50\text{pF}$

Symbol	Parameter	$V_{CC} = 3.3V \pm 0.15V$		Unit
		Min.	Max.	
t_{PLH} t_{PHL}	Propagation Delay CLK to xYx	1.8	3.5	ns

TEST CIRCUITS AND WAVEFORMS

TEST CONDITIONS

Symbol	V _{CC} ⁽¹⁾ = 3.3V ± 0.3V	V _{CC} ⁽¹⁾ = 2.7V	V _{CC} ⁽²⁾ = 2.5V ± 0.2V	Unit
V _{LOAD}	6	6	2 x V _{CC}	V
V _{IH}	2.7	2.7	V _{CC}	V
V _T	1.5	1.5	V _{CC} / 2	V
V _{LZ}	300	300	150	mV
V _{HZ}	300	300	150	mV
C _L	50	50	30	pF

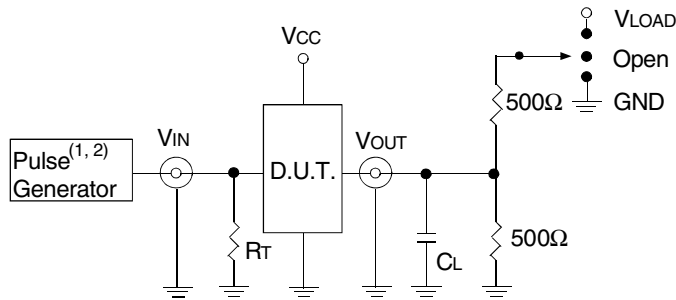

Test Circuit for All Outputs

DEFINITIONS:

C_L = Load capacitance: includes jig and probe capacitance.
R_T = Termination resistance: should be equal to Z_{OUT} of the Pulse Generator.

NOTES:

1. Pulse Generator for All Pulses: Rate ≤ 1.0MHz; t_r ≤ 2.5ns; t_r ≤ 2.5ns.
2. Pulse Generator for All Pulses: Rate ≤ 1.0MHz; t_r ≤ 2ns; t_r ≤ 2ns.

SWITCH POSITION

Test	Switch
Open Drain Disable Low Enable Low	V _{LOAD}
Disable High Enable High	GND
All Other Tests	Open

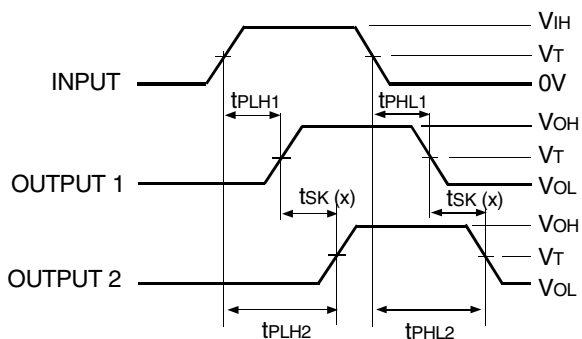

$$t_{SK}(x) = |t_{PLH2} - t_{PLH1}| \text{ or } |t_{PHL2} - t_{PHL1}|$$

Output Skew - t_{SK}(x)

NOTES:

1. For t_{SK}(a) OUTPUT1 and OUTPUT2 are any two outputs.
2. For t_{SK}(b) OUTPUT1 and OUTPUT2 are in the same bank.

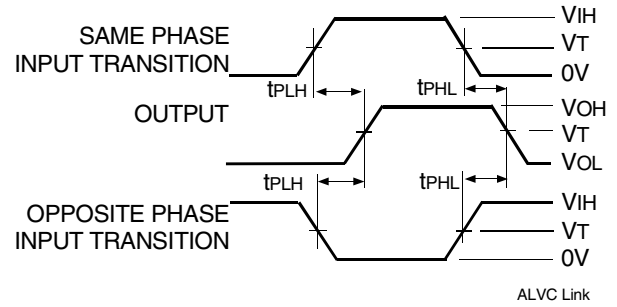

Propagation Delay

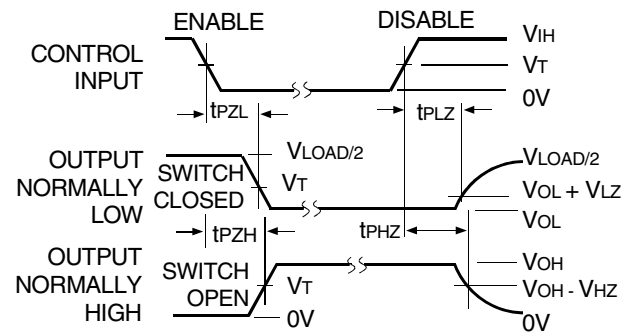

Enable and Disable Times

NOTE:

1. Diagram shown for input Control Enable-LOW and input Control Disable-HIGH.

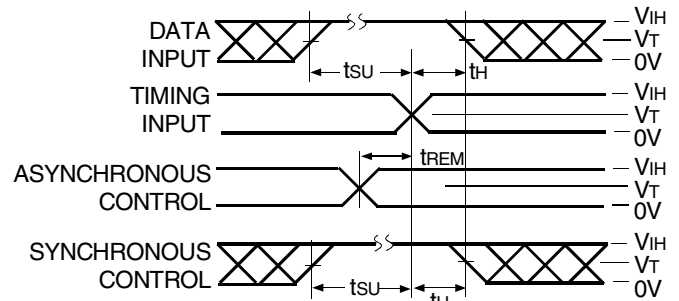

Set-up, Hold, and Release Times

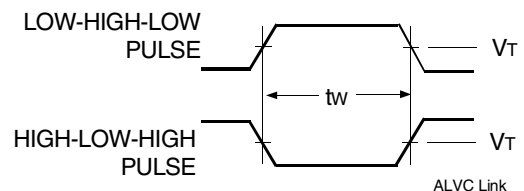

Pulse Width

ORDERING INFORMATION

<u>XX</u>	<u>ALVC</u>	<u>X</u>	<u>XXX</u>	<u>XXX</u>	<u>XX</u>	
Temp. Range	Bus-Hold	Family	Device Type	Package		
					PA	Thin Shrink Small Outline Package
					PAG	TSSOP - Green
					PF	Thin Very Small Outline Package
					PFG	TVSOP - Green
				835A		18-Bit Universal Bus Driver with 3-State Outputs
			F162			Double-Density with Resistors, ±18mA
		Blank				No Bus-hold
74						– 40°C to +85°C

IMPORTANT NOTICE AND DISCLAIMER

RENESAS ELECTRONICS CORPORATION AND ITS SUBSIDIARIES (“RENESAS”) PROVIDES TECHNICAL SPECIFICATIONS AND RELIABILITY DATA (INCLUDING DATASHEETS), DESIGN RESOURCES (INCLUDING REFERENCE DESIGNS), APPLICATION OR OTHER DESIGN ADVICE, WEB TOOLS, SAFETY INFORMATION, AND OTHER RESOURCES “AS IS” AND WITH ALL FAULTS, AND DISCLAIMS ALL WARRANTIES, EXPRESS OR IMPLIED, INCLUDING, WITHOUT LIMITATION, ANY IMPLIED WARRANTIES OF MERCHANTABILITY, FITNESS FOR A PARTICULAR PURPOSE, OR NON-INFRINGEMENT OF THIRD-PARTY INTELLECTUAL PROPERTY RIGHTS.

These resources are intended for developers who are designing with Renesas products. You are solely responsible for (1) selecting the appropriate products for your application, (2) designing, validating, and testing your application, and (3) ensuring your application meets applicable standards, and any other safety, security, or other requirements. These resources are subject to change without notice. Renesas grants you permission to use these resources only to develop an application that uses Renesas products. Other reproduction or use of these resources is strictly prohibited. No license is granted to any other Renesas intellectual property or to any third-party intellectual property. Renesas disclaims responsibility for, and you will fully indemnify Renesas and its representatives against, any claims, damages, costs, losses, or liabilities arising from your use of these resources. Renesas' products are provided only subject to Renesas' Terms and Conditions of Sale or other applicable terms agreed to in writing. No use of any Renesas resources expands or otherwise alters any applicable warranties or warranty disclaimers for these products.

(Disclaimer Rev.1.01 Jan 2024)

Corporate Headquarters

TOYOSU FORESIA, 3-2-24 Toyosu,
Koto-ku, Tokyo 135-0061, Japan
www.renesas.com

Trademarks

Renesas and the Renesas logo are trademarks of Renesas Electronics Corporation. All trademarks and registered trademarks are the property of their respective owners.

Contact Information

For further information on a product, technology, the most up-to-date version of a document, or your nearest sales office, please visit www.renesas.com/contact-us/.

Looking for pricing, stock, or lifecycle information?

Click below to explore more details on WIN SOURCE:

- ⊖ [View 74ALVCF162835APAG on WIN SOURCE](#)
- ⊖ [Renesas Electronics America Information](#)

Optimize Your Supply Chain with WIN SOURCE Solutions

- ✓ Global Sourcing Solution
- ✓ Obsolete Management
- ✓ Cost Control Management
- ✓ Shortage Management
- ✓ Alternative Solution
- ✓ Excess Inventory Management