



**THE DATASHEET OF
2SD315AI-33**



2SD315AI-33 Dual SCALE Driver Core for Halfbridge IGBTs up to 3300V

Description

The SCALE drivers from CONCEPT are based on a chip set that was developed specifically for the reliable driving and safe operation of IGBTs and power MOSFETs.

The name "SCALE" is an acronym for the most outstanding properties of the SCALE series of drivers:

SCALE = **S**caleable, **C**ompact, **A**ll purpose, **L**ow cost and **E**asy to use.

The SCALE driver is a winning project of the competition organized by "Technology Center Switzerland 1998". And ABB Switzerland AG honored the development of the SCALE driver by distinguishing it as the "best power electronics project in 1998".



Product Highlights

- ✓ Suitable for IGBTs up to 3300V blocking voltage
- ✓ Short circuit and overcurrent protection
- ✓ Extremely reliable, long service life
- ✓ High gate current of $\pm 15A$
- ✓ Electrical isolation of $6000V_{AC}$
- ✓ Electrically isolated status acknowledgement
- ✓ Monitoring of power supply and self-monitoring
- ✓ Switching frequency DC to $>100kHz$
- ✓ Duty cycle: 0... 100%
- ✓ High dv/dt immunity, guaranteed $>100,000V/\mu s$
- ✓ Complete with DC/DC converter

Applications

- ✓ Inverters
- ✓ Motor drive technology
- ✓ Traction
- ✓ Railroad power supplies
- ✓ Converters
- ✓ Power engineering
- ✓ Switched-mode power supplies
- ✓ Radiology and laser technology
- ✓ DC/DC converter
- ✓ Research
- ✓ RF generators and converters

Block Diagram

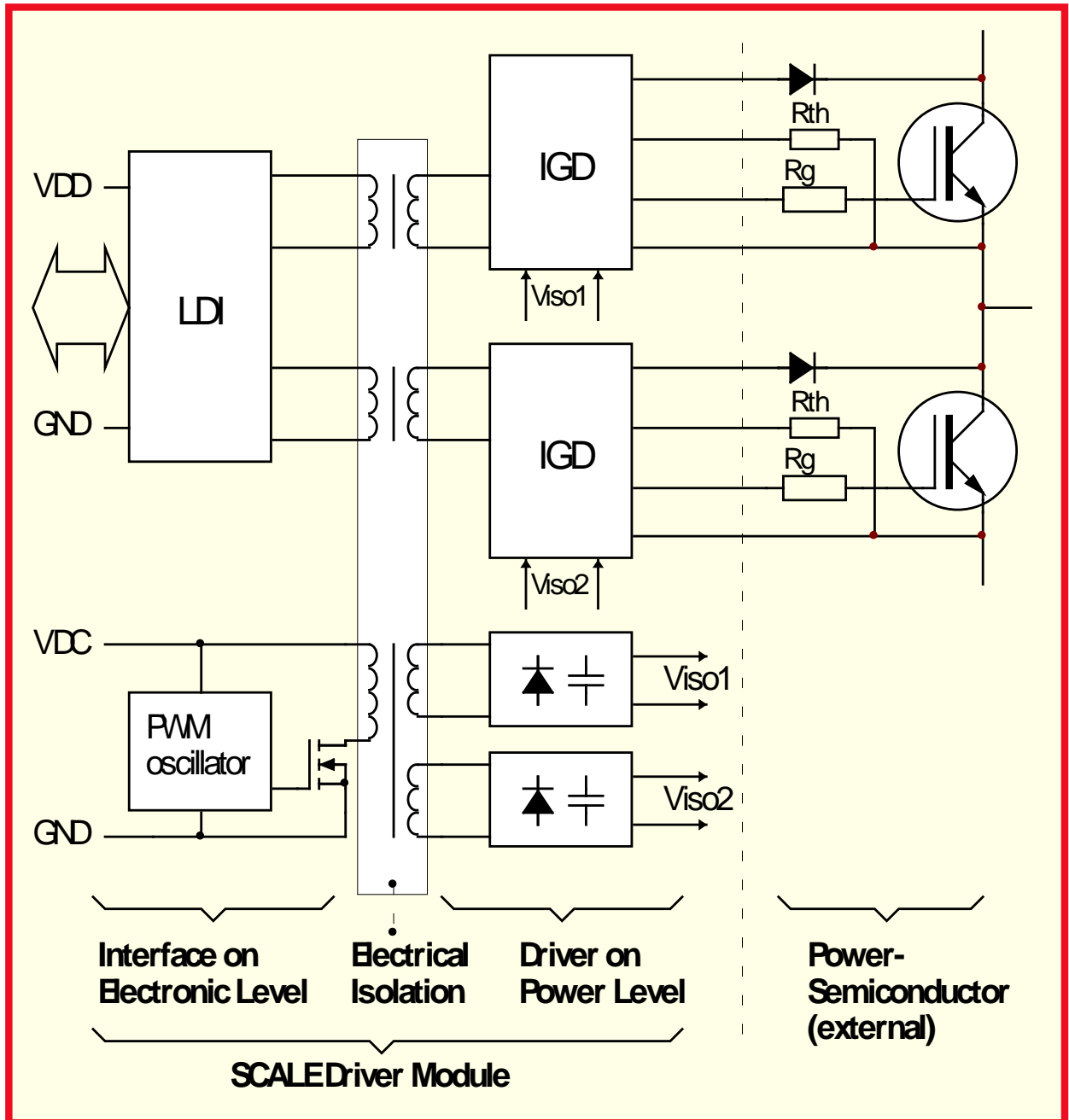

Fig. 1 Block diagram of the 2SD315AI-33

Pin Designation

Pin	Des.	Function	Pin	Des.	Function
1	VDD	+15V for electronic input side	44	G1	Gate channel 1
2	VDD	+15V for electronic input side	43	G1	Gate channel 1
3	SO1	Status output channel 1	42	COM1	Virtual common channel 1
4	VL	Logic level/Reset	41	COM1	Virtual common channel 1
5	RC1	RC network dead-time channel 1	40	Viso1	Blocking capacitor channel 1
6	InB	Input B	39	E1	Emitter channel 1
7	RC2	RC network dead-time channel 2	38	E1	Emitter channel 1
8	MOD	Mode input	37	Rth1	Reference resistor channel 1
9	SO2	Status output channel 2	36	C1	Collector sense channel 1
10	InA	Input A	35	LS1	Local status channel 1
11	GND	GND for electronic input side	34		Free
12	GND	GND for electronic input side	33		Free
13	VDC	+15V for DC/DC converter	32	G2	Gate channel 2
14	VDC	+15V for DC/DC converter	31	G2	Gate channel 2
15	VDC	+15V for DC/DC converter	30	COM2	Virtual common channel 2
16	VDC	+15V for DC/DC converter	29	COM2	Virtual common channel 2
17	VDC	+15V for DC/DC converter	28	Viso2	Blocking capacitor channel 2
18	GND(dc)	Ground DC/DC converter	27	E2	Emitter channel 2
19	GND(dc)	Ground DC/DC converter	26	E2	Emitter channel 2
20	GND(dc)	Ground DC/DC converter	25	Rth2	Reference resistor channel 2
21	GND(dc)	Ground DC/DC converter	24	C2	Collector sense channel 2
22	GND(dc)	Ground DC/DC converter	23	LS2	Local status channel 2

Legend:

Pins with the designation "Free" are not physically present.

PCB Layout / Mechanical Dimensions

Details of the circuit board layout

Grid of the aspect drawing on page 4 below: 1.27mm (50mil)

Recommended diameter of solder pad: Ø 1.6mm

Recommended diameter of drill holes: Ø 1.0mm

2SD315AI-33 Data Sheet

Mechanical Dimensions

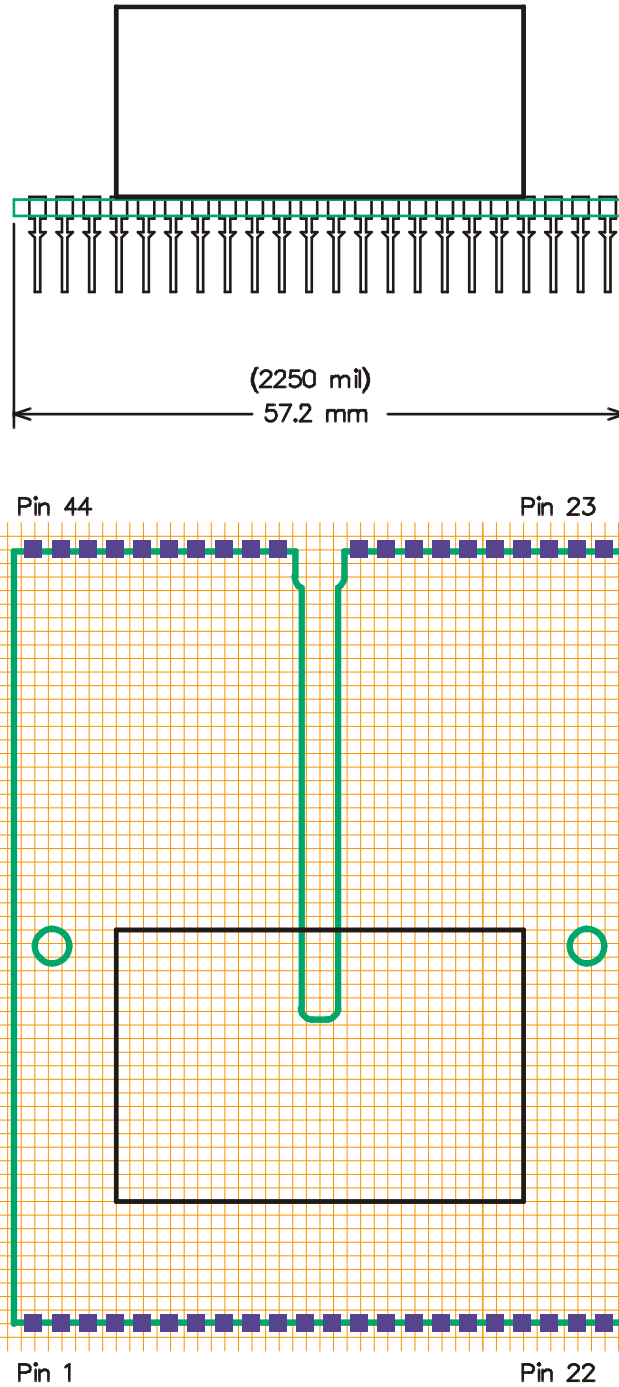

Fig 2 Front view (top) / Layout overview component side (bottom) 2SD315AI-33

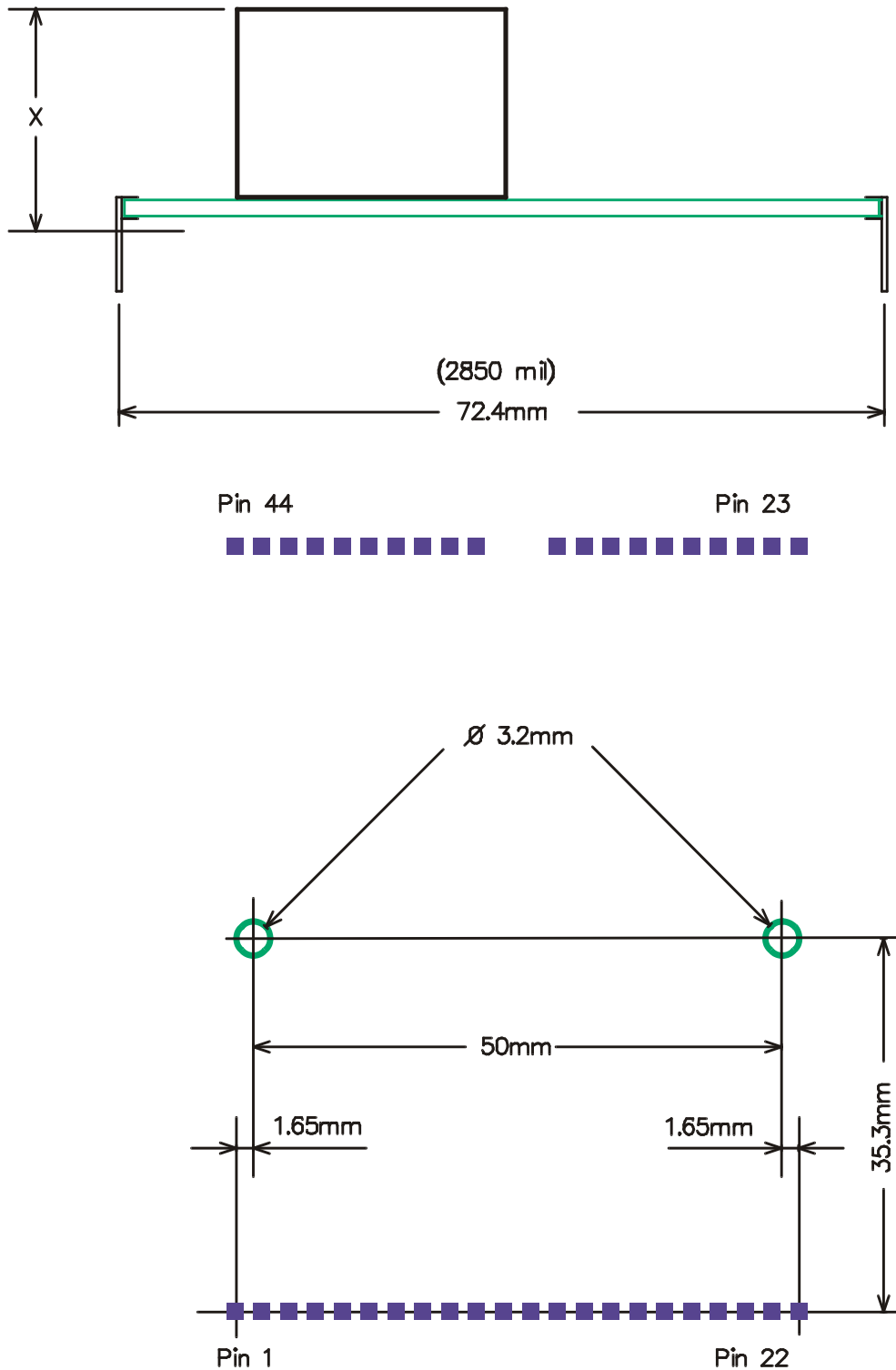

Fig. 3 Side view (top) / Mechanical fixing (bottom) 2SD315AI-33

Height X: typ. 22mm

2SD315AI-33 Data Sheet

Mechanical fixing

The 2SD315AI-33 driver has two holes each 3.2mm in diameter. They allow additional fixing of the driver for applications requiring very high resistance to shaking/vibration (railways, traction systems, electrically-driven vehicles, etc.). See Fig. 3 (bottom).

Absolute Maximum Ratings

Parameter	Test conditions	min	max	unit
Supply voltage V_{DC}		0	16	Vdc
Supply voltage V_{DD}		0	16	Vdc
Logic input voltage	to GND	0	V_{DD}	Vdc
Gate peak current I_{out}	Gx to Ex	-18	+18	A
Output power DC/DC converter	total for both channels		6	W
Operating voltage	continuous (see Note 8)		2000	Vdc
Max. test voltage (50Hz/1min)	inputs to outputs (see Note 11)		6000	$V_{AC}(eff)$
Operating temperature	(see Note 10)	-40	+85	°C
Storage temperature		-40	+90	°C

All data refer to +25°C and $V_{DD} = V_{DC} = 15V$ unless otherwise specified

Electrical Characteristics

Power supply	Test conditions	min	typ	max	unit
Nominal supply voltage V_{DC}	to GND (see Note 1)	15			Vdc
Supply current I_{DC}	without load	30			mA
Max. supply current I_{DC}	(see Note 2)			470	mA
Output power DC/DC converter	(see Note 3)			6	W
Efficiency η	internal DC/DC converter	85			%
Nominal supply voltage V_{DD}	to GND	15			Vdc
Supply current I_{DD}	without load	12			mA
Supply current I_{DD}	at 25kHz switching frequency	15			mA

Electrical Characteristics (Continuation)

Power supply monitoring	Test conditions	min	typ	max	unit
Turn-on threshold V_{th}	(see Note 4)		11.5		Vdc
Hysteresis on/off	(see Note 4)		0.7		Vdc
Logic inputs	Test conditions	min	typ	max	unit
Input voltage	all inputs (see Note 5)	0		V_{DD}	Vdc
Timing characteristics	Test conditions	min	typ	max	unit
Delay time input to output	turn-on $t_{pd(on)}$		300		ns
	turn-off $t_{pd(off)}$		350		ns
Blocking time	after failure (see Note 12)		1		s
Outputs	Test conditions	min	typ	max	unit
Output current I_G	Gx to Ex (see Note 6)	-15		+15	A
Output rise time $t_{r(out)}$	Gx to Ex (see Note 7)		100/160		ns
Output fall time $t_{f(out)}$	Gx to Ex (see Note 7)		80/130		ns
Output current SOx		1.5			mA
Output voltage rating SOx	SOx to GND			V_{DD}	V
Output current LSx		5			mA
Vce-Monitoring	Test conditions	min	typ	max	unit
Inputs Cx	to Ex	0		V_{DD}	Vdc
Electrical isolation	Test conditions	min	typ	max	unit
Operating voltage	continuous (see Note 8)			2000	Vdc
Max. test voltage	(50Hz/1min) (see Note 11)			6000	$V_{AC}(eff)$
Partial discharge extinction volt. IEC270			>3300		$V_{AC}(pk)$
Creep path input-output			20		mm
Creep path output-output			20		mm
Maximum $*V/*t$ at $*V = 1000V$	(see Note 9)	100			kV/ s

All data refer to +25°C and $V_{DD} = V_{DC} = 15V$ unless otherwise specified

2SD315AI-33 Data Sheet

Operating Conditions

Operating conditions	Test conditions	min	max	unit
Operating temperature	(see Note 10)	-40	+85	°C
Storage temperature		-40	+90	°C

Footnotes to the key data

- 1) The drivers have a zener diode on each channel for over-voltage protection. When the feed voltage exceeds 16V, this protection can be subject to thermal overload.
- 2) If the specified power consumption is exceeded, this indicates an overload of the DC/DC converter. It should be noted that these DC/DC converters are not protected against overload.
- 3) This should be considered as a recommended value. Please consult the section: "Output power and self-heating".
- 4) Under-voltage monitoring for protecting the power semiconductors. The voltage refers to the local supply voltage of each individual drive channel. However, this corresponds approximately to the voltage at VDC with respect to GND.
- 5) The input levels must never exceed the limits of the supply voltage (i.e. between GND and VDD), otherwise latch-up of the integrated circuits LDI 001 can occur. Particular care must be taken when driving via cables or longer leads.
- 6) The gate current must be limited to its maximum value by a gate resistor.
- 7) First value: At a load of 39nF in series with 5.6Ω/Second value: At a load of 250nF in series with 1.8Ω
- 8) Maximum continuous or repeatedly-applied DC voltage between all inputs and all outputs.
- 9) This specification guarantees that the drive information will be transferred reliably even at a high DC-link voltage and fastest switching operations.
- 10) The application-specific self-heating of the drivers – specially at high load – must be taken into account.
- 11) The test voltage of 6000 Vac(rms)/50Hz may be applied only once during one minute. It should be noted that with this (strictly speaking obsolete) test method, some (minor) damage occurs to the isolation layers due to the partial discharge. Consequently, this test is not performed at CONCEPT as a series test. In the case of repeated isolation tests (e.g. module test, equipment test, system test) the subsequent tests should be performed with a lower test voltage: the test voltage is reduced by 600V for each additional test. The more modern if more elaborate partial-discharge measurement is better suited than such test methods as it is almost entirely non-destructive.
- 12) The typical blocking time after an error is 1 second. If required, versions with other blocking times may also be supplied.

Application Hints

IMPORTANT INFORMATION

This data sheet contains only product-specific data. All data that apply to the whole type series of SCALE drivers is given in the document entitled: "Description and Application Manual for SCALE Drivers". In particular, this manual contains a detailed description of the concept of the SCALE drivers, a description of the function of all terminal pins as well as other important application hints.

Overview and application

The SCALE driver 2SD315AI-33 is a two channel driver for power MOSFETs and IGBTs. The 2SD315AI-33 combines compact mechanical dimensions and a simple electrical interface with very high output currents, high drive power and a special high isolation. This driver can thus be used in almost all conceivable applications, especially for parallel circuits, high-power modules and modules with reverse voltages up to 3300V. When used as a half-bridge driver, the 2SD315AI-33 can directly generate any dead times that may be required.

Output power and self-heating

The specified output power of the driver totals 6W (3W per channel). In the case of a drive power of 6W, the typical input power of the driver is about 7W; the losses due to the driver total about 1W. Because CONCEPT cannot predict how the drivers will be incorporated in the user's application, no binding recommended value for self-heating and thus for the maximum useful output power at high ambient temperatures can be made. It is consequently recommended to check the self-heating of the system, especially when it is used at higher temperatures.

For the calculation of the exact output power, reference should be made to Application Note AN-9701 "IGBT drivers correctly calculated" on www.igbt-driver.com/go/app-note.

2SD315AI-33 Data Sheet

Collector sense and dimensioning of Rth

The 2SD315AI-33 dual driver has a collector-sense circuit to protect the power semiconductors. It is shown in Fig. 4

Its basic operating mode can be obtained from the brochure entitled: "Description and Application Manual for Scale Drivers".

To correspond more effectively to the turn-on characteristic of the IGBTs, the SCALE drivers do not use a static reference voltage to compare the voltage at the collector. Instead, the reference is used as shown in Fig. 5.

In order to ensure that the 2SD315AI-33 can be applied as universally as possible, the components Ca (response time capacitor) and Rm (attenuation resistor) are not integrated in the driver as shown in Fig. 4, but must be connected externally. Whereas Ca can be matched to the specific application, a standard value of 180Ω is recommended for Rm. The ground terminal of Ca should be connected to the COMx pin.

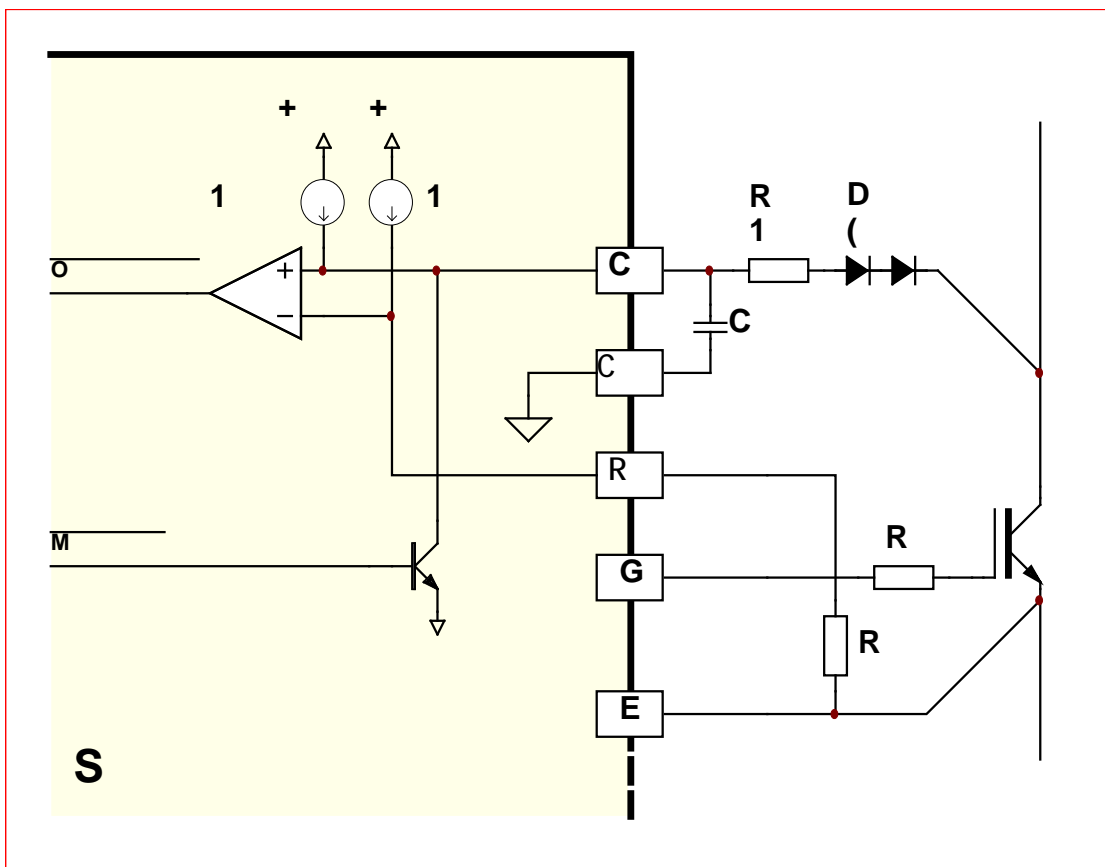
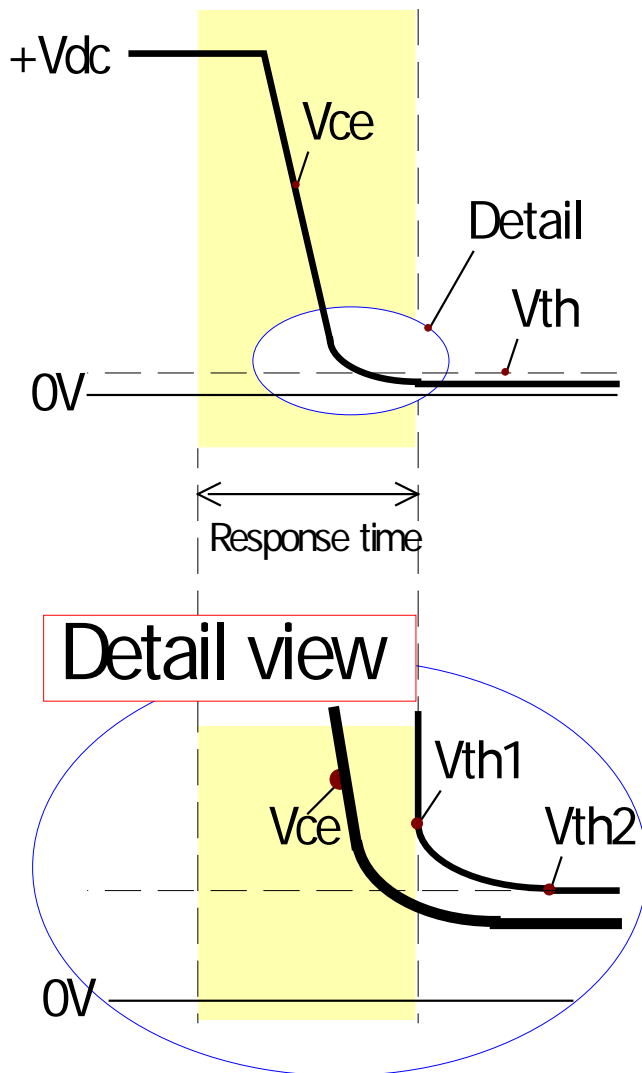

Fig. 4 Collector-sense circuit principle



Notes on Table 1

The values for "Vth1" and "Vth2" are listed in **Table 1** as a function of the reference resistance Rth.

The value in the "Vth1" column corresponds to the voltage threshold after the response time has elapsed.

The value in the "Vth2" column corresponds to the voltage which is set up statically across the resistor Rth. This static value is typically reached after between 10 and 15 μ s.

The value in the "V_{CE(off)}" column corresponds to the collector-emitter voltage value at which the protection function is activated when the external circuit is used as shown in Fig. 4 with one or two Dm diodes of type 1N4007 connected in series.

A value of 1n5 is used for the response time capacitor Ca. If this capacitor is rated higher or lower, the response time changes in proportion to the change in capacitance, whereas the thresholds Vth1 and Vth2 remain practically unchanged (they are specified by Rth).

Fig. 5 Collector-sense voltage curve

Value Rth	Reaction time	Vth1	Vth2	V _{CE(off)}
22k	4.9 s	4.8V	3.2V	2.35V (1 Diode)
27k	5.7 s	5.6V	3.9V	3.05V (1 Diode)
33k	6.8 s	6.5V	4.7V	3.25V (2 Diodes)
39k	7.6 s	7.3V	5.6V	4.15V (2 Diodes)
47k	9 s	8.4V	6.8V	5.35V (2 Diodes)

Table 1 Reference resistor, reaction time and turn-off threshold with Ca = 1n5

2SD315AI-33 Data Sheet

Double or multiple pins

Due to the high output currents, several pins are present in duplicate or as multiples. It is recommended to connect these in parallel on the layout so that the voltage drop across the lead frames (contact pins) is minimized.

Special terminal pins

The 2SD315AI-33 half-bridge driver is optimized for universal use and high driver performance and thus contains more terminal pins than the compact SCALE drivers. These pins will be described below:

Visox and COMx pins: external support capacitor

Note: The “x” in Visox and COMx stands for the channel number.

Like the compact SCALE drivers, the 2SD315AI-33 also has blocking capacitors on the secondary side of the DC/DC converter for each drive channel. IGBTs with gate charges up to 3 C (corresponding typically to about a 1200V/300A module) and gate currents up to about 10A can be driven without external blocking capacitors. At higher gate charges or gate currents, external blocking capacitors are required between Visox and COMx. These capacitors should be rated at between 47 and 120 F (but no more than 220 F) and a dielectric strength of 20V. It is important that the capacitors are suitable for switched-mode power supply applications (low inductance and high current handling capacity). They must be connected as close as possible to the driver’s terminal pins with minimum inductance.

The anode of the capacitor is connected to Visox, its cathode to COMx. The COMx pin is always present in duplicate.

VDC and GND pins: supply for DC/DC Converter

It is recommended to connect a blocking capacitor of approximately 220µF to the driver input. This capacitor should also be of the switched-mode power supply type.

Pin LSx: Local status

Note: The “x” in LSx stands for the channel number.

The status of the IGD 001 for each channel is available at this output. It is an open-collector output to which approximately 5mA may be applied. A LED can be connected here, for example, as shown in Fig. 6. The LED lights up in normal operation

(everything OK) and goes out when the driver detects an undervoltage or during the blocking time.

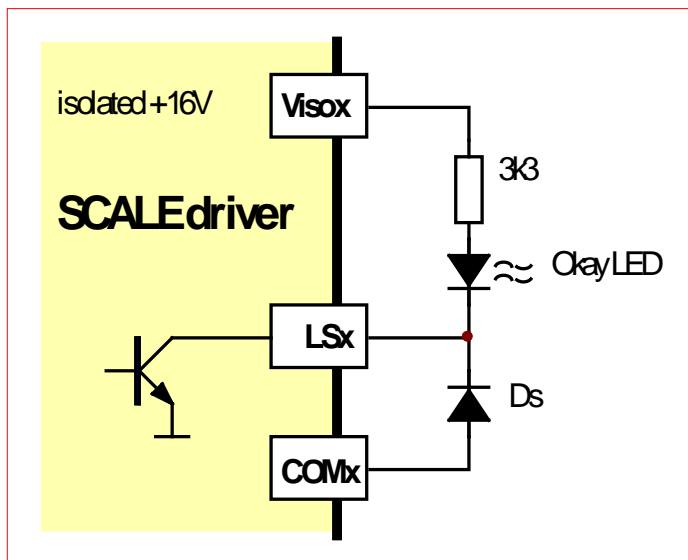

Fig. 6 Status display with LED at pin LSx

Attention:

The Schottky diode Ds should not be omitted if the local status outputs are used. If the local status outputs are not used, LS1 should be connected to COM1 and LS2 to COM2 in order to increase the noise immunity of the driver.

Configuration within the Power Section

The drivers should be located as closely as possible to the power transistors. The connecting leads to the transistors should be as short as possible and as low inductance as possible, i.e. they can be up to 3cm to 10cm long depending on the gate current and switching speed.

2SD315AI-33 Data Sheet

If you need any help, simply call our technical support

CONCEPT provides expert help with your questions and problems:

www.IGBT-Driver.com/go/support

Quite special: customized SCALE drivers

If you need a power MOSFET or IGBT driver that is not included in the delivery range, don't hesitate to contact CONCEPT or your CONCEPT sales partner.

CONCEPT engineers have more than 20 years experience in the development and manufacture of intelligent drivers for power MOSFETs and IGBTs and have already implemented a large number of customized solutions.

Important Notice

The data contained in this product data sheet is intended exclusively for technically trained staff. Handling all high-voltage equipment involves risk to life. Strict compliance with the respective safety regulations is mandatory!

Any handling of electronic devices is subject to the general specifications for protecting electrostatic-sensitive devices according to international standard IEC 747-1, Chapter IX or European standard EN 100015 (i.e. the workplace, tools, etc. must comply with these standards). Otherwise, this product may be damaged.

Legal Disclaimer

This data sheet specifies devices but cannot promise to deliver any specific characteristics. No warranty or guarantee is given – either expressly or implicitly – regarding delivery, performance or suitability.

CT-Concept Technologie AG reserves the right to make modifications to its technical data and product specifications at any time without prior notice. The general terms and conditions of delivery of CT-Concept Technologie AG apply.

Ordering Information

Dual SCALE driver with $\pm 15\text{A}$ gate current / $0/+15\text{V}$ or $\pm 15\text{V}$ gate voltage

2SD315AI-33

Information about Other Products

For other drivers, product documentation, and application support

Direct link: Please click: www.IGBT-Driver.com

Manufacturer

CT-Concept Technologie AG
Intelligent Power Electronics
Renferstrasse 15
CH-2504 Biel-Bienne
Switzerland

Tel. +41 - 32 - 344 47 47

Fax +41 - 32 - 344 47 40

E-mail Info@IGBT-Driver.com

Internet www.IGBT-Driver.com

© Copyright 1998...2009 by CT-Concept Technologie AG - Switzerland.

All rights reserved.

We reserve the right to make any technical modifications without prior notice. Version from 2016-05-20

Looking for pricing, stock, or lifecycle information?

Click below to explore more details on WIN SOURCE:

- [View 2SD315AI-33 on WIN SOURCE](#)
- [Power Integrations Information](#)

Optimize Your Supply Chain with WIN SOURCE Solutions

- ✓ Global Sourcing Solution
- ✓ Obsolete Management
- ✓ Cost Control Management
- ✓ Shortage Management
- ✓ Alternative Solution
- ✓ Excess Inventory Management