

LMX2505 PLLatinum™ Dual Frequency Synthesizer System with Integrated VCOs

Check for Samples: [LMX2505](#)

FEATURES

- **Small Size**
 - 5.0 mm X 5.0 mm X 0.75 mm 28-Pin WQFN Package
- **RF Synthesizer System**
 - Two Integrated VCOs
 - Integrated Loop Filter
 - Low Spurious, Low Phase Noise Fractional-N RF PLL Based on 10-Bit Delta Sigma Modulator
 - Frequency Resolution Down to 20 kHz
- **Supports Various Reference Frequencies**
 - 12.6/14.4/25.2/26.0 MHz
- **Fast Lock Time: 300 μs**
- **Low Current Consumption**
 - 10 mA at 2.8 V in PDC800 Mode
- **2.5 V to 3.3 V Operation**
- **Digital Filtered Lock Detect Output**
- **Hardware and Software Power Down Control**

APPLICATIONS

- **Japan PDC Systems at 800 MHz and 1500 MHz Frequency Bands**

DESCRIPTION

LMX2505 is a highly integrated, high performance, low power frequency synthesizer system optimized for dual-band Japan PDC mobile handsets. Using a proprietary digital phase locked loop technique, LMX2505 generates very stable, low noise local oscillator signals for up and down conversion in wireless communications devices.

LMX2505 includes dual voltage controlled oscillators (VCOs) for the upper and lower Japan PDC frequency bands, a loop filter, and a fractional-N RF PLL based on a delta sigma modulator. In concert these blocks form a closed loop RF synthesizer system. The RF synthesizer system supports two frequency bands: PDC1500 and PDC800.

Serial data is transferred to the device via a three-wire MICROWIRE interface (DATA, LE, CLK).

Operating supply voltage ranges from 2.5 V to 3.3 V. LMX2505 features low current consumption: 10 mA at 2.8 V when operating in the PDC800 mode.

LMX2505 is available in a 28-pin WQFN package.

Functional Block Diagram

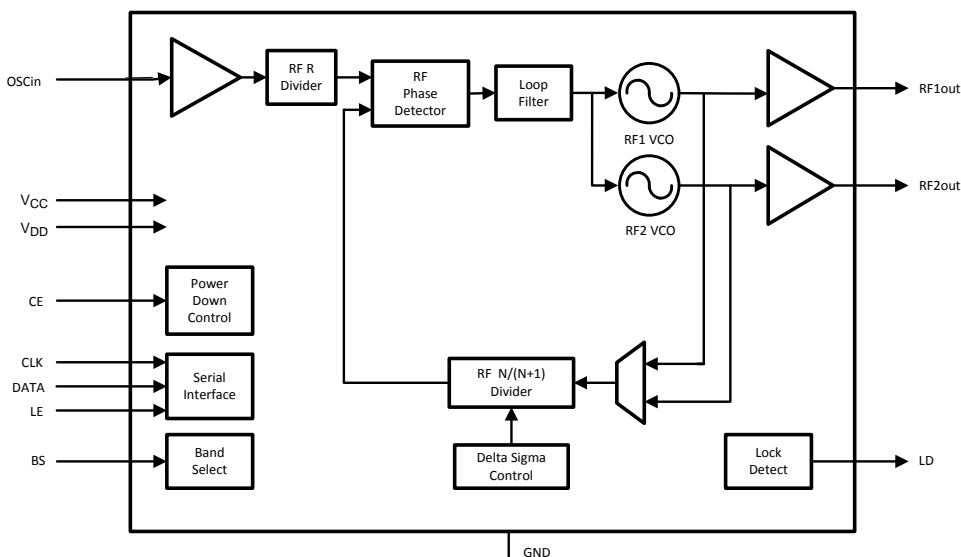

Please be aware that an important notice concerning availability, standard warranty, and use in critical applications of Texas Instruments semiconductor products and disclaimers thereto appears at the end of this data sheet.

PLLatinum is a trademark of Texas Instruments.

All other trademarks are the property of their respective owners.

PIN DESCRIPTIONS (continued)

Pin Number	Name	I/O	Description
28	V _{CC}	—	Supply voltage for digital circuitry

Typical Application Circuit

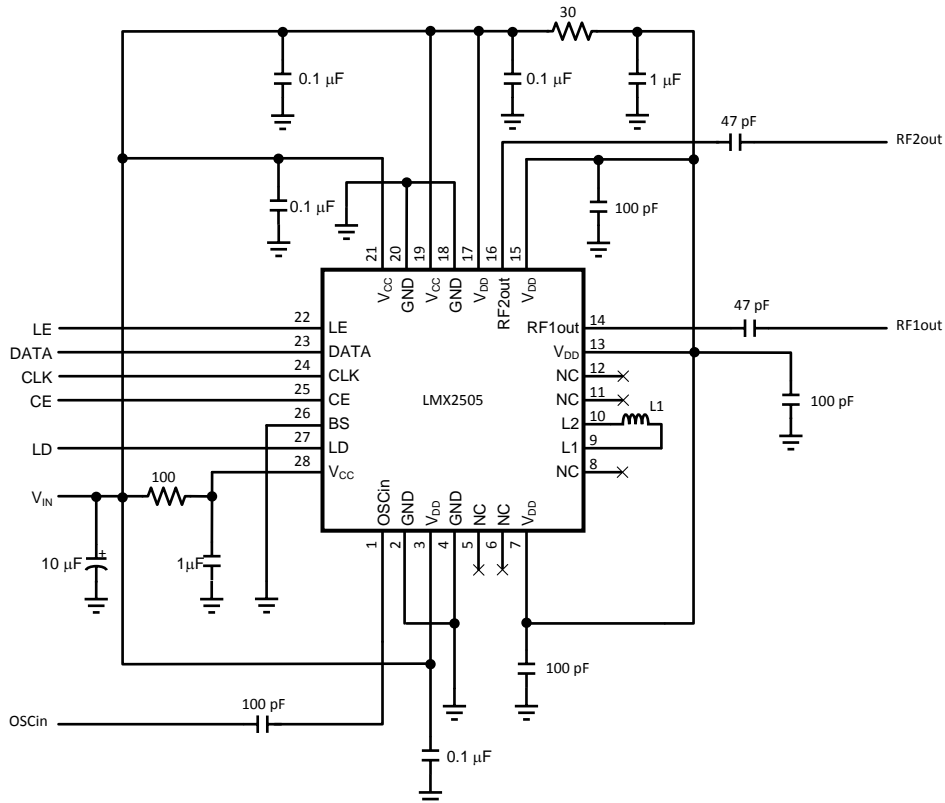

Refer to RF2 VCO Tuning Range vs. External Inductance plot to aid in selecting the appropriate external inductance, PCB trace and L1, for the desired frequency range.

Figure 2. Typical Application Circuit



These devices have limited built-in ESD protection. The leads should be shorted together or the device placed in conductive foam during storage or handling to prevent electrostatic damage to the MOS gates.

Absolute Maximum Ratings^{(1)(2) (3)(4)}

Parameter	Symbol	Ratings	Units
Supply Voltage	V _{CC} , V _{DD}	-0.5 to 3.6	V
Voltage on any pin to GND	V _I	-0.3 to V _{CC} +0.3	V
		-0.3 to V _{DD} +0.3	V
Storage Temperature Range	T _{STG}	-65 to 150	°C

- (1) Absolute Maximum Ratings indicate limits beyond which damage to the device may occur. Recommended Operating Conditions indicate conditions for which the device is intended to be functional, but do not guarantee specific performance limits. For guaranteed specifications and test conditions, refer to the Electrical Characteristics section. The guaranteed specifications apply only for the conditions listed.
- (2) This device is a high performance RF integrated circuit with an ESD rating < 2 kV and is ESD sensitive. Handling and assembly of this device should be done at ESD protected workstations.
- (3) GND = 0 V.
- (4) If Military/Aerospace specified devices are required, please contact the Texas Instruments Sales Office/Distributors for availability and specifications.

Recommended Operating Conditions

Parameter	Symbol	Min	Typ	Max	Unit
Ambient Temperature	T _A	-30	25	85	°C
Supply Voltage (to GND)	V _{CC} , V _{DD}	2.5		3.3	V

Electrical Characteristics⁽¹⁾

(V_{IN} = 2.8 V, refer to Typical Application Circuit; Limits in standard typeface are for T_A = 25 °C; Limits in **boldface** type apply over the operating temperature range from -20 °C ≤ T_A ≤ 75 °C unless otherwise noted.)

Symbol	Parameter	Condition	Min	Typ	Max	Units
I_{CC} PARAMETERS						
I _{CC} + I _{DD}	Supply Current ⁽²⁾	OB_CRL [1:0] = 11		11.5	13.0 13.3	mA
		OB_CRL [1:0] = 00		10.0	11.5 11.8	mA
I _{CC} + I _{DD}	Supply Current ⁽³⁾	OB_CRL [1:0] = 11		16.0	17.5 17.8	mA
		OB_CRL [1:0] = 00		14.2	15.6 15.9	mA
I _{PD}	Power Down Current	CE = LOW or RF_PD = 1			20	μA
REFERENCE OSCILLATOR PARAMETERS						
f _{OSCin}	Reference Oscillator Input Frequency ⁽⁴⁾	12.6/14.4/25.2/26.0 MHz are supported.	12.6	14.4	26.0	MHz
V _{OSCin}	Reference Oscillator Input Sensitivity			0.5	V _{CC}	Vp-p
RF1 VCO for PDC1500						
f _{RF1out}	Frequency Range ⁽⁵⁾	RF1 VCO for PDC1500	1270.22		1394.95	MHz
P _{RF1out}	Output Power	OB_CRL [1:0] = 11	-5	-2	1	dBm
		OB_CRL [1:0] = 10	-7	-4	-1	dBm
		OB_CRL [1:0] = 01	-10	-7	-4	dBm
		OB_CRL [1:0] = 00	-13	-10	-7	dBm
	Lock Time	Full frequency span within each band in High Speed Mode.			300 ⁽⁶⁾	μs
		Between bands High Speed Mode.			300 ⁽⁶⁾	μs
		Full frequency span within each band in Normal Mode.			500 ⁽⁶⁾	μs
					375 ⁽⁷⁾	μs
		Between bands in Normal Mode.			500 ⁽⁶⁾	μs
					400 ⁽⁷⁾	μs
	RMS Phase Error			1.3		degrees

(1) All limits are ensured. All electrical characteristics having room temperature limits are tested during production with T_A = 25 °C or correlated using Statistical Quality Control (SQC) methods. All hot and cold limits are ensured by correlating the electrical characteristics to process and temperature variations and applying statistical process control.

(2) RF PLL and VCO in PDC800 mode.

(3) RF PLL and VCO in PDC1500 mode.

(4) The reference frequency must also be programmed using the OSC_FREQ control bit. For other reference frequencies, please contact Texas Instruments.

(5) For other frequency ranges, please contact Texas Instruments.

(6) Lock time is defined as the time difference between the beginning of the frequency transition and the point at which the frequency remains within +/-1 kHz of the final frequency.

(7) Lock time is defined as the time difference between the beginning of the frequency transition and the point at which the frequency remains within +/-3 kHz of the final frequency.

Electrical Characteristics⁽¹⁾ (continued)

($V_{IN} = 2.8\text{ V}$, refer to Typical Application Circuit; Limits in standard typeface are for $T_A = 25\text{ }^\circ\text{C}$; Limits in **boldface** type apply over the operating temperature range from $-20\text{ }^\circ\text{C} \leq T_A \leq 75\text{ }^\circ\text{C}$ unless otherwise noted.)

Symbol	Parameter	Condition	Min	Typ	Max	Units
$L(f)_{RF1out}$	Phase Noise when RF1 VCO for PDC1500 is activated in Normal Mode.	@ 25 kHz offset		-95	-93 -91	dBc/Hz
		@ 50 kHz offset		-106	-103 -101	dBc/Hz
		@ 100 kHz offset		-115	-113 -111	dBc/Hz
		@ 1 MHz offset			-135 -133	dBc/Hz
	2nd Harmonic Suppression				-25	dBc
	3rd Harmonic Suppression				-20	dBc
	Spurious Tones	@ $\leq 25\text{ kHz}$ offset			-45	dBc
		@ $25\text{ kHz} < \text{offset} \leq 50\text{ kHz}$			-60	dBc
		@ $50\text{ kHz} < \text{offset} \leq 100\text{ kHz}$			-69	dBc
		@ offset $> 100\text{ kHz}$			-75	dBc
RF2 VCO for PDC800						
f_{RF2out}	Frequency Range ⁽⁵⁾	RF2 VCO for PDC800	633.15		768	MHz
P_{RF2out}	Output Power	OB_CRL [1:0] = 11	-6	-3	0	dBm
		OB_CRL [1:0] = 10	-9	-6	-3	dBm
		OB_CRL [1:0] = 01	-11	-8	-5	dBm
		OB_CRL [1:0] = 00	-15	-12	-9	dBm
	Lock Time	Full frequency span within each band in High Speed Mode.			300 ⁽⁶⁾	μs
					300 ⁽⁶⁾	μs
		Full frequency span within each band in Normal Mode.			500 ⁽⁶⁾	μs
					375 ⁽⁷⁾	μs
					500 ⁽⁶⁾	μs
	Between bands in Normal Mode.			400 ⁽⁷⁾	μs	
	RMS Phase Error			1.3		degrees
$L(f)_{RF2out}$	Phase Noise when RF2 VCO for PDC800 is activated in Normal Mode.	@ 25 kHz offset		-95	-93 -91	dBc/Hz
		@ 50 kHz offset		-106	-103 -101	dBc/Hz
		@ 100 kHz offset		-115	-113 -111	dBc/Hz
		@ 1 MHz offset			-135 -133	dBc/Hz
	2nd Harmonic Suppression				-25	dBc
	3rd Harmonic Suppression				-20	dBc
	Spurious Tones	@ $\leq 25\text{ kHz}$ offset			-45	dBc
		@ $25\text{ kHz} < \text{offset} \leq 50\text{ kHz}$			-60	dBc
		@ $50\text{ kHz} < \text{offset} \leq 100\text{ kHz}$			-69	dBc
		@ offset $> 100\text{ kHz}$			-75	dBc
DIGITAL INTERFACE (DATA, CLK, LE, LD, CE, BS)						
V_{IH}	High-Level Input Voltage		$0.8 V_{CC}$		V_{CC}	V
			$0.8 V_{DD}$		V_{DD}	V
V_{IL}	Low-Level Input Voltage		-0.3		$0.2 V_{CC}$	V
			-0.3		$0.2 V_{DD}$	V
I_{IH}	High-Level Input Current		-10		10	μA

Electrical Characteristics⁽¹⁾ (continued)

($V_{IN} = 2.8\text{ V}$, refer to Typical Application Circuit; Limits in standard typeface are for $T_A = 25\text{ }^\circ\text{C}$; Limits in **boldface** type apply over the operating temperature range from $-20\text{ }^\circ\text{C} \leq T_A \leq 75\text{ }^\circ\text{C}$ unless otherwise noted.)

Symbol	Parameter	Condition	Min	Typ	Max	Units
I_{IL}	Low-Level Input Current		-10		10	μA
	Input Capacitance			3		pF
	Rise/Fall Time			30		ns
V_{OH}	High-Level Output Voltage		$V_{CC} - 0.4$			V
			$V_{DD} - 0.4$			V
V_{OL}	Low-Level Output Voltage				0.4	V
	Output Capacitance				5	pF
MICROWIRE INTERFACE TIMING						
t_{CS}	Data to Clock Set Up Time		50			ns
t_{CH}	Data to Clock Hold Time		10			ns
t_{CWH}	Clock Pulse Width HIGH		50			ns
t_{CWL}	Clock Pulse Width LOW		50			ns
t_{ES}	Clock to Latch Enable Set Up Time		50			ns
t_{EW}	Latch Enable Pulse Width		50			ns

Figure 3. Microwire Interface Timing Diagram

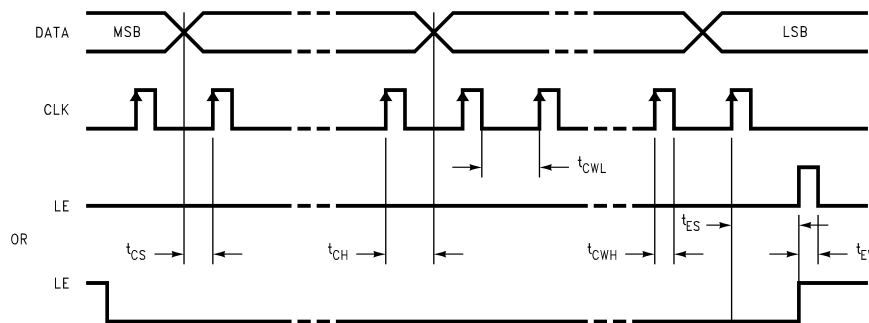

Typical Performance Characteristics⁽¹⁾

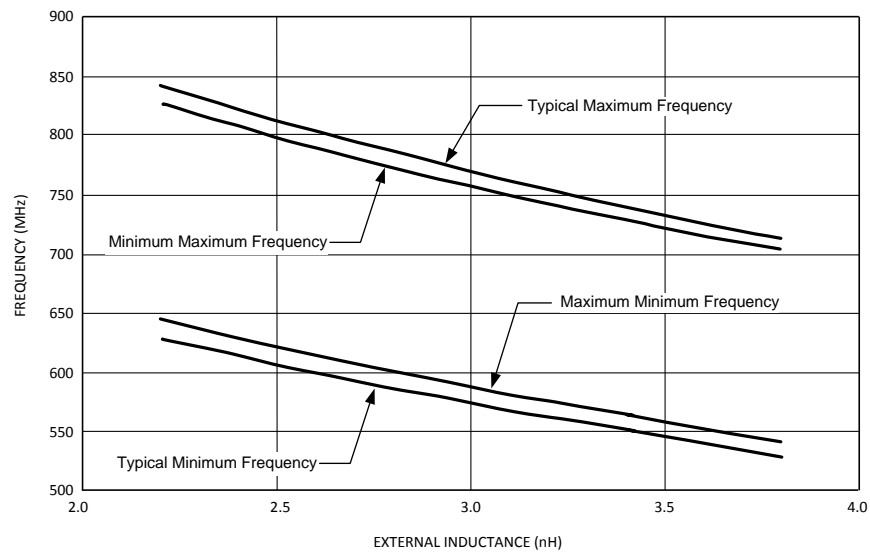

The frequency range is defined as the difference between the highest frequency and the lowest frequency of a given unit. For a chosen external inductance, the typical frequency range equals the difference between the Typical Maximum Frequency and the Typical Minimum Frequency. Typical frequency range may be assumed on any unit with that chosen external inductance, even if the unit has worst case Maximum Frequency or worst case Minimum Frequency.

Figure 4. RF2 VCO Tuning Range vs. External Inductance $V_{IN} = 2.8\text{ V}$

- (1) Typical performance characteristics do not ensure specific performance limits. For ensured specifications, refer to the Electrical Characteristics section.

FUNCTIONAL DESCRIPTION

GENERAL

The LMX2505 is a highly integrated frequency synthesizer system for Japan PDC wireless communication systems. The LMX2505 supports dual band operation for 800 MHz and 1500 MHz.

The LMX2505 includes all functional blocks for the RF PLL including RF VCOs, frequency dividers, PFDs, and loop filters. Only external passive elements for the RF2 VCO tank and supply bypassing are required to complete the RF synthesizer.

The LMX2505 uses a patent pending Fractional-N synthesizer architecture based on a delta sigma modulator to support fine frequency resolution. Four of the most common reference frequencies for PDC applications, 12.6 MHz, 14.4 MHz, 25.2 MHz and 26.0 MHz, are supported. The unique feature of this architecture is its low spurious modulation effect.

The use of a fractional synthesizer based on delta sigma modulator allows for fast lock-up and system set-up times, which reduces system power consumption. The loop filter is included in the circuit to minimize the external noise coupling and reduce the form factor applicable to the board level application. Only one of the two RF VCOs is activated at a given time, and each output is provided through its own output pin.

RF_PLL SECTION

Frequency Selection

The divide ratio can be calculated using the following equations:

$$f_{VCO} = \{8 \times RF_B + RF_A + (RF_FN / FD)\} \times (f_{OSC} / R) \text{ where } (RF_A < RF_B) \text{ for PDC1500}$$

$$f_{VCO} = \{4 \times RF_B + RF_A + (RF_FN / FD)\} \times (f_{OSC} / R) \text{ where } (RF_A < RF_B) \text{ for PDC800}$$

where

- f_{VCO} : Output frequency of voltage controlled oscillator (VCO)
- RF_B: Preset divide ratio of binary 4-bit programmable counter ($2 \leq RF_B \leq 15$)
- RF_A: Preset divide ratio of binary 3-bit swallow counter ($0 \leq RF_A \leq 7$ for PDC1500 and $0 \leq RF_A \leq 3$ for PDC800)
- RF_FN: Preset numerator of binary 10-bit modulus counter ($0 \leq RF_FN < FD$)
- FD: Preset denominator for modulus counter ($FD = f_{OSC} / (R \times f_{CH})$ where f_{CH} is the channel spacing)
- f_{OSC} : Reference oscillator frequency
- R: Internal reference oscillator frequency divider (1 for 12.6 MHz and 14.4 MHz, 2 for 25.2 MHz and 26.0 MHz)

The denominator, FD, in the above equation is dependent on the channel spacing and reference oscillator frequency. The channel spacing will change based on the Rx/Tx and BS bits. [Table 8](#) in the R0 Register section summarizes the values of FD.

VCO Frequency Tuning

The center frequency of the RF VCOs is determined by the resonant frequency of the tank circuit, illustrated in [Figure 5](#). With an internal fixed bonding-wire inductor and an external inductance, the center frequency of the VCO is given as follows:

$$f_{center} = \frac{1}{2\pi \sqrt{(L_{fixed} + L_{external}) \cdot C_{total}}}$$

where C_{total} is the total capacitance of the VCO, including the parasitic capacitance and the nominal self-tuning capacitance. Note, the external inductance consists of the PCB traces and lumped element inductor. The output frequency tuning range can be optimized for the specific application by selecting the appropriate external inductance. Refer to RF2 VCO Tuning Range vs. External Inductance plot to aid in selecting the appropriate external inductance. Care should be taken to ensure proper frequency coverage when choosing the tolerance of the lumped element inductor. For the 1500 MHz band, the internal bonding-wires provide the necessary inductance to set the VCO center frequency.

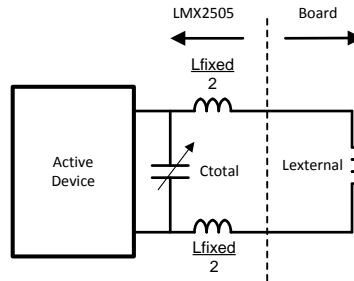

Figure 5. External Inductor Connection

In real implementation, the inductance of L_{fixed} and $L_{external}$ can vary from its nominal value. The LMX2505 utilizes a built-in tracking algorithm to compensate for variations up to $\pm 15\%$ and tunes the VCO to the required frequency. During the frequency acquisition period, the loop bandwidth is extended to achieve the frequency lock. After the frequency lock, the loop bandwidth of the PLL is set to the nominal value and the phase lock is achieved. The transition between the two operating modes is very smooth and extremely fast to meet the stringent PDC requirements for lock time and phase noise.

POWER DOWN MODE

The LMX2505 includes the power down mode to reduce the power consumption. The LMX2505 enters the power down mode either by taking the CE pin LOW or by setting the RF_PD bit in the R0 register. If the CE pin is set LOW, the circuit is powered down regardless of the register values. When the CE pin is HIGH, the RF_PD bit controls power to the RF circuitry. Data can be written to the registers even when the CE pin is set LOW. The following truth table summarizes the power down logic.

Table 1. Power Down Modes

CE Pin	RF_PD Bit	Mode
HIGH	0	Active
HIGH	1	Not Active
LOW	0	Not Active
LOW	1	Not Active

BAND SELECT MODE

The BS pin and BS bit can be used to select one of the two RF VCO outputs. When using the BS pin, the BS bit must be set to 0, and when using the BS bit, the BS pin must be tied to ground. When using the BS pin, the state of the input must exceed the minimum band select set up time prior to the LE signal transition. The truth table summarizing the band select logic is as follows:

Table 2. Band Select Modes

BS Pin	BS Bit	Mode
HIGH	0	PDC1500
LOW	0	PDC800
LOW	1	PDC1500

LOCK DETECT MODE

The LD output can be used to indicate the lock status of the PLL. Bit 6 in Register R1 determines the signal that appears on the LD pin. When the PLL is not locked, the LD pin remains LOW. After obtaining phase lock, the LD pin will have a logical HIGH level. The LD output is always LOW when the LD register bit is 0 and in power down mode.

Table 3. Lock Detect Modes

LD Bit	Mode
0	Disable (GND)
1	Enable

Table 4. Lock Detect Logic

RF PLL Section	LD Output
Locked	HIGH
Not Locked	LOW

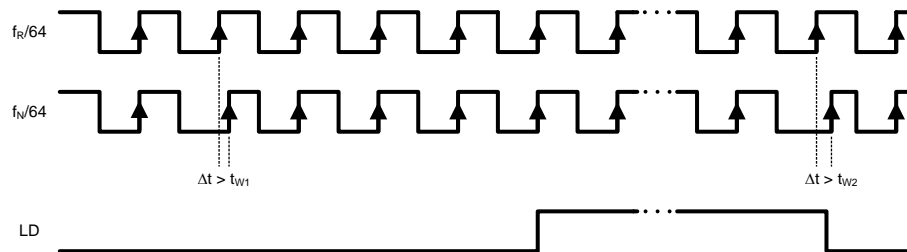

- (1) LD output becomes LOW when the phase error is larger than t_{W2} .
- (2) LD output becomes HIGH when the phase error is less than t_{W1} for four or more consecutive cycles.
- (3) Phase Error is measured on leading edge. Only errors greater than t_{W1} and t_{W2} are labeled.
- (4) t_{W1} is 5 ns for PDC1500 and 10 ns for PDC800. t_{W2} is 10 ns for both bands.
- (5) The lock detect comparison occurs with every 64th cycle of f_R and f_N .

Figure 6. Lock Detect Timing Diagram Waveform

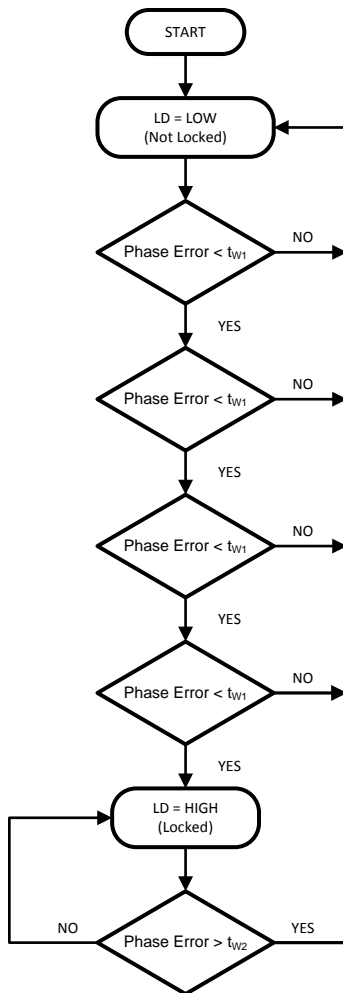

Figure 7. Lock Detect Flow Diagram

HIGH SPEED LOCK-UP MODE

Two frequency-locking modes are provided: a Normal mode and a High Speed mode for faster lock times. The HS bit in register R0 controls the locking mode.

Table 5. Lock-up Modes

HS Bit	Mode
0	Normal mode
1	High Speed mode

MICROWIRE INTERFACE

The programmable register set is accessed via the MICROWIRE serial interface. The interface is comprised of three signal pins: CLK, DATA, and LE (Latch Enable). Serial data is clocked into the 24-bit shift register on the rising edge of the clock. The last bits decode the internal control register address. When the latch enable (LE) transitions from LOW to HIGH, data stored in the shift registers is loaded into the corresponding control register. The data is loaded MSB first.

Programming Description

GENERAL PROGRAMMING INFORMATION

The serial interface has a 24-bit shift register to store the incoming data bits temporarily. The incoming data is first loaded into the shift register from MSB to LSB. The data is shifted at the rising edge of the clock signal. When the latch enable signal transitions from LOW to HIGH, the data stored in shift register is transferred to the proper register depending on the address bit setting. The selection of the particular register is determined by the control bits indicated in boldface text.

At initial start-up, the MICROWIRE loading requires three default words (registers R2, loaded first, to R0, loaded last). After the device has been initially programmed, the RF VCO frequency can be changed using a single register (R0).

The control register content map describes how the bits within each control register are allocated to the specific control functions.

Table 6. COMPLETE REGISTER MAP⁽¹⁾⁽²⁾

Regi ster	MSB	SHIFT REGISTER BIT LOCATION																				LSB				
	23	22	21	20	19	18	17	16	15	14	13	12	11	10	9	8	7	6	5	4	3	2	1	0		
R0 (Default)	RX/ TX	RF_ PD	HS	0	BS	RF_B [3:0]			RF_A [2:0]			RF_FN [9:0]										0	0			
R1 (Default)	SPL_ DEF	0	0	1	0	0	1	0	1	0	0	0	0	0	0	1	0	LD	OB_ CRL [1:0]	OSC_ FREQ [1:0]	0	1	1	0	1	
R2 (Default)	1	1	0	0	1	0	0	0	0	1	1	1	1	0	0	0	0	0	0	0	0	1	1	0	1	0
R3	1	0	0	0	0	1	1	0	1	0	0	0	0	0	0	0	0	0	0	0	1	1	0	1	1	1
R4	0	0	0	0	0	0	1	1	1	0	1	0	0	0	1	1	0	0	1	0	0	1	1	1	1	1
R5	0	0	0	0	0	0	0	0	0	0	0	0	0	0	0	0	0	0	0	0	0	0	0	0	0	0

- (1) **NOTE:** R0 control register will be used when hot start frequency change.
- (2) **NOTE:** Boldface text represent address bits.

R0 REGISTER

The R0 register address bits (R0 [1:0]) are “00”.

The Rx/Tx bit selects between receive and transmit modes and, in conjunction with the band select bit (BS), the channel spacing to be synthesized.

The RF_PD bit selects the power down mode of the RF PLL and selected VCO.

The HS bit selects between normal and high speed locking mode.

The BS bit determines which of the two internal VCOs (PDC800 or PDC1500) is active.

The RF N counter consists of the 4-bit programmable counter (RF_B counter), the 3-bit swallow counter (RF_A counter) and the 10-bit delta sigma modulator (RF_FN counter). The equations for calculating the counter values are presented below.

Table 7. R0 REGISTER

Register	MS B	SHIFT REGISTER BIT LOCATION																				LS B		
		23	22	21	20	19	18	17	16	15	14	13	12	11	10	9	8	7	6	5	4		3	2
		Data Field																				Address Field		
R0 (Default)	RX / TX	RF _ PD	HS	0	BS	RF_B [3:0]				RF_A [2:0]			RF_FN [9:0]										0	0

Name	Functions
RX/TX	RX/TX Mode 0 = Rx 1 = Tx
RF_PD	Power Down of RF Synthesizer 0 = RF synthesizer on (Active mode) 1 = RF synthesizer powered down
HS	Locking Mode 0 = Normal Mode 1 = High Speed Mode
BS	Band Select 1 = RF1 VCO (PDC1500) 0 = RF2 VCO (PDC800)
RF_B [3:0]	RF_B Counter 4-bit programmable counter 0 ≤ RF_B ≤ 15 for both bands
RF_A [2:0]	RF_A Counter 3-bit swallow counter 0 ≤ RF_A ≤ 7 for PDC1500 0 ≤ RF_A ≤ 3 for PDC800
RF_FN [9:0]	RF_FN Counter 10-bit modulus counter 0 ≤ RF_FN < FD See Table 8 for FD values.

Counter Name	Symbol	Functions
Modulus Counter	RF_FN	RF N Divider N = 8 x RF_B + RF_A + RF_FN/FD (PDC1500) N = 4 x RF_B + RF_A + RF_FN/FD (PDC800)
Programmable Counter	RF_B	
Swallow Counter	RF_A	

PULSE SWALLOW FUNCTION

$f_{VCO} = \{8 \times RF_B + RF_A + (RF_FN / FD)\} \times f_{OSC} / R$ where $(RF_A < RF_B)$ for PDC1500

$f_{VCO} = \{4 \times RF_B + RF_A + (RF_FN / FD)\} \times f_{OSC} / R$ where $(RF_A < RF_B)$ for PDC800

f_{VCO} : Output frequency of voltage controlled oscillator (VCO)

RF_B : Preset divide ratio of binary 4-bit programmable counter ($2 \leq RF_B \leq 15$)

RF_A : Preset divide ratio of binary 3-bit swallow counter ($0 \leq RF_A \leq 7$ for PDC1500 and $0 \leq RF_A \leq 3$ for PDC800)

RF_FN : Preset numerator of binary 10-bit modulus counter ($0 \leq RF_FN < FD$)

FD : Preset denominator for modulus counter ($FD = f_{OSC} / (R \times f_{CH})$ where f_{CH} is the channel spacing)

f_{OSC} : Reference oscillator frequency

R: Internal reference oscillator frequency divider

OSC_FREQ [1:0]	Reference Oscillator Frequency (MHz)	R Divider
00	12.6	1
01	14.4	1
10	25.2	2
11	26.0	2

The value of the denominator (FD) is depended on the channel spacing and reference oscillator frequency. [Table 8](#) summarizes the denominator values based on the settings of the Rx/Tx, BS, and OSC_FREQ [1:0] bits.

Table 8. Demonimator Values

Rx/Tx	BS	OSC_FREQ [1:0]	Reference Oscillator Frequency (MHz)	R	f_{CH} (kHz)	Denominator (FD)
0	0	00	12.6	1	25.0	504
0	0	01	14.4	1	25.0	576
0	0	10	25.2	2	25.0	504
0	0	11	26.0	2	25.0	520
0	1	00	12.6	1	25.0	504
0	1	01	14.4	1	25.0	576
0	1	10	25.2	2	25.0	504
0	1	11	26.0	2	25.0	520
1	0	00	12.6	1	20.0	630
1	0	01	14.4	1	20.0	720
1	0	10	25.2	2	20.0	630
1	0	11	26.0	2	20.0	650
1	1	00	12.6	1	22.22	567
1	1	01	14.4	1	22.22	648
1	1	10	25.2	2	22.22	567
1	1	11	26.0	2	22.22	585

R1 REGISTER

The R1 register address bits (R1 [1:0]) are "01".

The SPI_DEF bit allows for the programming of words R3 to R5. Under most circumstances, the SPI_DEF bit should be set to 1.

The LD bit sets the function of the lock detect pin. Enabling the lock detect function provides a digital lock detect output of the active RF synthesizer at the LD pin.

The OB_CRL [1:0] bits determine the power level of the RF output buffer. The power level can be adjusted to best meet the system requirement.

The reference frequency selection bits, OSC_FREQ [1:0], are used to set the reference clock and R divider for use with one of the following reference frequencies: 12.6 MHz, 14.4 MHz, 25.2 MHz or 26.0 MHz. The LMX2505 uses the OSC_FREQ bits along with the BS and RX/TX bits to determine the correct divide ratios needed to meet the required channel spacing for the mode of operation selected. Refer to [Table 8](#) for a summary of denominator values.

Table 9. R1 REGISTER

Register	MS B	SHIFT REGISTER BIT LOCATION																				LS B	
		23	22	21	20	19	18	17	16	15	14	13	12	11	10	9	8	7	6	5	4		3
		Data Field																				Address Field	
R1 (Default)	SPI _ D E F	0	0	1	0	0	1	0	1	0	0	0	0	0	0	1	0	LD	OB_CRL [1:0]	OSC_FREQ [1:0]	0	1	

Name	Functions
SPI_DEF	Default Register Selection 0 = OFF (Use values set in R0 to R5) 1 = ON (Use default values set in R0 to R2)
LD	Lock Detect 0 = Disable (GND) 1 = Enable
OB_CRL [1:0]	Output Buffer Control PDC1500, PDC800 00 = -10 dBm, -12 dBm 01 = -7 dBm, -8 dBm 10 = -4 dBm, -6 dBm 11 = -2 dBm, -3 dBm
OSC_FREQ [1:0]	Reference Frequency Selection 00 = 12.6 MHz 01 = 14.4 MHz 10 = 25.2 MHz 11 = 26.0 MHz

R2 REGISTER

The R2 register address bits (R2 [1:0]) are "10".

Table 10. R2 REGISTER

Register	MS B	SHIFT REGISTER BIT LOCATION																				LS B				
		23	22	21	20	19	18	17	16	15	14	13	12	11	10	9	8	7	6	5	4		3	2	1	0
		Data Field																				Address Field				
R2 (Default)	1	1	0	0	1	0	0	0	0	1	1	1	1	0	0	0	0	0	0	0	0	0	0	1	1	0

R3 REGISTER

The R3 register address bits (R3 [2:0]) are “011”. This register is only written to if the SPI_DEF bit is set to 0.

Table 11. R3 REGISTER

Register	MS B	SHIFT REGISTER BIT LOCATION																				LS B			
	23	22	21	20	19	18	17	16	15	14	13	12	11	10	9	8	7	6	5	4	3	2	1	0	
	Data Field																				Address Field				
R3	1	0	0	0	0	1	1	0	1	0	0	0	0	0	0	0	0	0	0	0	1	1	0	1	1

R4 REGISTER

The R4 register address bits (R4 [3:0]) are “0111”. This register is only written to if the SPI_DEF bit is set to 0.

Table 12. R4 REGISTER

Register	MS B	SHIFT REGISTER BIT LOCATION																				LS B			
	23	22	21	20	19	18	17	16	15	14	13	12	11	10	9	8	7	6	5	4	3	2	1	0	
	Data Field																				Address Field				
R4	0	0	0	0	0	0	1	1	1	0	1	0	0	0	1	1	0	0	1	0	0	1	1	1	1

R5 REGISTER

The R5 register address bits (R5 [4:0]) are “01111”. This register is only written to if the SPI_DEF bit is set to 0.

Table 13. R5 REGISTER

Register	MS B	SHIFT REGISTER BIT LOCATION																				LS B						
	23	22	21	20	19	18	17	16	15	14	13	12	11	10	9	8	7	6	5	4	3	2	1	0				
	Data Field																				Address Field							
R5	0	0	0	0	0	0	0	0	0	0	0	0	0	0	0	0	0	0	0	0	0	0	0	1	1	1	1	1

IMPORTANT NOTICE

Texas Instruments Incorporated and its subsidiaries (TI) reserve the right to make corrections, enhancements, improvements and other changes to its semiconductor products and services per JESD46, latest issue, and to discontinue any product or service per JESD48, latest issue. Buyers should obtain the latest relevant information before placing orders and should verify that such information is current and complete. All semiconductor products (also referred to herein as "components") are sold subject to TI's terms and conditions of sale supplied at the time of order acknowledgment.

TI warrants performance of its components to the specifications applicable at the time of sale, in accordance with the warranty in TI's terms and conditions of sale of semiconductor products. Testing and other quality control techniques are used to the extent TI deems necessary to support this warranty. Except where mandated by applicable law, testing of all parameters of each component is not necessarily performed.

TI assumes no liability for applications assistance or the design of Buyers' products. Buyers are responsible for their products and applications using TI components. To minimize the risks associated with Buyers' products and applications, Buyers should provide adequate design and operating safeguards.

TI does not warrant or represent that any license, either express or implied, is granted under any patent right, copyright, mask work right, or other intellectual property right relating to any combination, machine, or process in which TI components or services are used. Information published by TI regarding third-party products or services does not constitute a license to use such products or services or a warranty or endorsement thereof. Use of such information may require a license from a third party under the patents or other intellectual property of the third party, or a license from TI under the patents or other intellectual property of TI.

Reproduction of significant portions of TI information in TI data books or data sheets is permissible only if reproduction is without alteration and is accompanied by all associated warranties, conditions, limitations, and notices. TI is not responsible or liable for such altered documentation. Information of third parties may be subject to additional restrictions.

Resale of TI components or services with statements different from or beyond the parameters stated by TI for that component or service voids all express and any implied warranties for the associated TI component or service and is an unfair and deceptive business practice. TI is not responsible or liable for any such statements.

Buyer acknowledges and agrees that it is solely responsible for compliance with all legal, regulatory and safety-related requirements concerning its products, and any use of TI components in its applications, notwithstanding any applications-related information or support that may be provided by TI. Buyer represents and agrees that it has all the necessary expertise to create and implement safeguards which anticipate dangerous consequences of failures, monitor failures and their consequences, lessen the likelihood of failures that might cause harm and take appropriate remedial actions. Buyer will fully indemnify TI and its representatives against any damages arising out of the use of any TI components in safety-critical applications.

In some cases, TI components may be promoted specifically to facilitate safety-related applications. With such components, TI's goal is to help enable customers to design and create their own end-product solutions that meet applicable functional safety standards and requirements. Nonetheless, such components are subject to these terms.

No TI components are authorized for use in FDA Class III (or similar life-critical medical equipment) unless authorized officers of the parties have executed a special agreement specifically governing such use.

Only those TI components which TI has specifically designated as military grade or "enhanced plastic" are designed and intended for use in military/aerospace applications or environments. Buyer acknowledges and agrees that any military or aerospace use of TI components which have **not** been so designated is solely at the Buyer's risk, and that Buyer is solely responsible for compliance with all legal and regulatory requirements in connection with such use.

TI has specifically designated certain components as meeting ISO/TS16949 requirements, mainly for automotive use. In any case of use of non-designated products, TI will not be responsible for any failure to meet ISO/TS16949.

Products

Audio	www.ti.com/audio
Amplifiers	amplifier.ti.com
Data Converters	dataconverter.ti.com
DLP® Products	www.dlp.com
DSP	dsp.ti.com
Clocks and Timers	www.ti.com/clocks
Interface	interface.ti.com
Logic	logic.ti.com
Power Mgmt	power.ti.com
Microcontrollers	microcontroller.ti.com
RFID	www.ti-rfid.com
OMAP Applications Processors	www.ti.com/omap
Wireless Connectivity	www.ti.com/wirelessconnectivity

Applications



Automotive and Transportation	www.ti.com/automotive
Communications and Telecom	www.ti.com/communications
Computers and Peripherals	www.ti.com/computers
Consumer Electronics	www.ti.com/consumer-apps
Energy and Lighting	www.ti.com/energy
Industrial	www.ti.com/industrial
Medical	www.ti.com/medical
Security	www.ti.com/security
Space, Avionics and Defense	www.ti.com/space-avionics-defense
Video and Imaging	www.ti.com/video

TI E2E Community

e2e.ti.com

Looking for pricing, stock, or lifecycle information?

Click below to explore more details on WIN SOURCE:

-  [View LMX25051321EVAL/NOPB on WIN SOURCE](#)
-  [Texas Instruments](#) Information

Optimize Your Supply Chain with WIN SOURCE Solutions

-  Global Sourcing Solution
-  Obsolete Management
-  Cost Control Management
-  Shortage Management
-  Alternative Solution
-  Excess Inventory Management