



**THE DATASHEET OF  
204-125ST**



# AFBR-24x8xZ

## DC-50MBd Miniature Link Fiber Optic Receiver



## Data Sheet



### Description

The component is designed to provide cost effective, high performance fiber optic communication links for information systems and industrial applications with link distances of up to 2 km. The receivers are directly compatible with popular “industry-standard” connectors: ST and SMA. They are designed for use with 50/125  $\mu\text{m}$ , 62.5/125  $\mu\text{m}$ , and 200  $\mu\text{m}$  multimode fiber.

### AFBR-24x8xZ Available Part Numbers

Part Number	Description
AFBR-2408Z	Receiver with SMA port
AFBR-2418Z	Receiver with ST port
AFBR-2418TZ	Receiver with threaded ST port
AFBR-2418MZ	Receiver with metal ST port

### Link Length

Data Rate (MBd)	Max. Distance (m)	Fiber Size ( $\mu\text{m}$ )	Transmitter
50	900	50/125	HFBR-1414Z
50	2000	62.5/125	HFBR-1414Z
50	100	200	HFBR-1414Z

Note:

Verified with PRBS7 pattern using HFBR-1414Z transmitter, respecting its worst case LOP conditions but assuming a proper fiber connection (direct connection without add. connectors). Multiple or weak connections may reduce the achievable link length.

### Features

- RoHS-compliant
- Work with Avago HFBR-14xxZ (820nm LED) transmitter
- Data transmission at signal rates from DC up to 50 MBd
- Receiver: Integrated PIN diode and digitalizing IC with CMOS/TTL output logic
- Up to 2 km distance with Multimode Glass Fiber Cable
- Operating temperature range of  $-40^{\circ}\text{C}$  to  $+85^{\circ}\text{C}$
- 3.3 V and 5 V supply voltage operation
- RSSI output

### Applications

- Optical transmission from DC up to 50 MBd
- Industrial control and factory automation
- High voltage isolation
- Elimination of ground loops
- Reduces voltage transient susceptibility
- Power substation automation

## Package and Handling Information

### Package Information

The receiver is housed in a low-cost, dual-inline package that is made of high strength, heat resistant, chemically resistant, and UL 94V-O flame retardant ULTEM® plastic (UL File #E121562). The receivers (suffix Z, TZ) are easily identified by the dark grey color connector port. A metal port option is also available (suffix MZ). The metal port option components have an internal electrical connection between the metal port and the four grounding pins, as shown in the package outline drawing. Signal ground is separate from the four grounding pins to give flexibility in connecting the port to signal or chassis ground. The package is designed for auto-insertion and wave soldering so it is ideal for high volume production applications.

### Handling and Design Information

Each part comes with a protective port cap or plug covering the optics. These caps/plugs will vary by port style. When soldering, it is advisable to leave the protective cap on the unit to keep the optics clean. Good system performance requires clean port optics and cable ferrules to avoid obstructing the optical path. Clean compressed air often is sufficient to remove particles of dirt; methanol on a cotton swab also works well.

## AFBR-24x8xZ Low-Cost 50 MBd Receiver

### Description

The AFBR-24x8xZ fiber optic receiver is designed to operate with the Avago Technologies HFBR-14xZ fiber optic transmitters and multimode glass fiber cable. Consistent coupling into the receiver is assured by the optical system with lens. The receiver output is a digital CMOS/TTL signal. The AFBR-24x8xZ receiver contains an IC with integrated photodiode which directly converts the incoming optical signal to a digital output signal without the requisite for additional external circuitry. Because of its integrated design, the receiver has very high EMC resistance. A wide receiver dynamic range and high sensitivity over temperature is achievable. The data rate typically goes from DC to 50MBd. A monitor (RSSI) output, which delivers an output current proportional to the average incoming light power, is available.

For an almost noise-free RSSI-signal smoothing components are recommended. A capacitor in parallel to the resistor on the RSSI output reduces potential high frequency signal parts. The use of a single 100 nF capacitor for signal smoothing is sufficient in most common applications, as shown in the Recommended Receiver Circuitry section. If this RSSI function is not required, the output pin can be left floating. The RSSI-signal is derived from internal controlling loops; therefore, the typical time constant of pure RSSI output current without an external filter can be up to 1 ms. This time constant also depends on the actual average incoming light power.

## Absolute Maximum Ratings

Parameter	Symbol	Min	Max	Unit	Notes
Storage Temperature	T <sub>S</sub>	-40	+85	°C	
Operating Temperature	T <sub>A</sub>	-40	+85	°C	
Supply Voltage	V <sub>CC</sub>	-0.3	5.5	V	
Maximum DC Output Current	I <sub>O</sub>		10	mA	
Voltage at RSSI Output	V <sub>RSSI</sub>	-0.3	V <sub>CC</sub> +0.3	V	
Lead Soldering Cycle - Temp	T <sub>SOLD</sub>		260	°C	1.6 mm below seating plane
Lead Soldering Cycle - Time	t <sub>SOLD</sub>		10	s	

## Electrical/Optical Characteristics

-40° C to +85° C, 3.135 V < V<sub>CC</sub> < 5.25 V

Parameter	Symbol	Min	Typ <sup>[1]</sup>	Max	Unit	Condition	Notes
Optical Input Peak Power Range (50 MBd proprietary)	P <sub>IN-50</sub>	-24		+1	dBm	DR=50MBd	2, 3, 4
Optical Spectrum Range	λ <sub>IN</sub>	792	820	865	nm	peak wavelength	
Data Rate	DR	DC		50	MBd		
Supply Voltage	V <sub>CC</sub>	3.135		5.25	V		
Supply Current	I <sub>CC</sub>		20	30	mA	R <sub>L</sub> =2kΩ	
High Level Output Voltage	V <sub>OH</sub>	2.4	V <sub>CC</sub> -0.3	V <sub>CC</sub>	V	R <sub>L</sub> =2kΩ	
Low Level Output Voltage	V <sub>OL</sub>		0.2	0.4	V	R <sub>L</sub> =2kΩ	
Output Rise Time (10-90%)	t <sub>R</sub>			5	ns	C <sub>L</sub> =10pF	2, 4
Output Fall Time (90-10%)	t <sub>F</sub>			5	ns	C <sub>L</sub> =10pF	2, 4
Pulse Width Distortion	PWD	-4		+4	ns		4, 8
Pulse Width Distortion 1st to 3rd pulse	PWD <sub>INIT</sub>	-5		+8	ns		6, 7, 8
Propagation Delay	t <sub>RD</sub>			40	ns		8
RSSI Output Responsivity	I <sub>RSSI</sub> /P <sub>IN</sub>		0.72		A/W		5
Voltage at RSSI Output	V <sub>RSSI</sub>	0		V <sub>CC</sub> -1	V		

Notes:

1. Typical data are at 25° C, V<sub>CC</sub> = 5.0 V.
2. In recommended receiver circuit, with an optical signal from the recommended transmitter circuit, transmitted via 62.5/125μm MM fiber.
3. Condition for sensitivity limit: Total Jitter ≤ 0.6 UI (unit intervals). The sensitivity was characterized by usage of transmitter HFBR-1414Z, an optical attenuator for the particular power setting and a short piece of fiber (a few meters). The use of long fiber connections up to max. link length, as specified in the table "Link Length" on page 1, may reduce the sensitivity.
4. Verified with a PRBS7 signal with mark ratio = ½ running at 50 MBd (in this case, the optical input average power levels are 3dB less than the specified peak power levels).
5. Verified with an external resistor R<sub>RSSI</sub>=2 kΩ
6. If the data rate was below 1 MBd, the pulse width distortion would be equal to the pulse width distortion of the 1st to 3rd pulses for higher data rates.
7. The threshold of the 1st pulse of a data sequence is difficult to adjust and therefore the pulse width distortion up to the 3rd pulse is higher than for all other pulses (worst case for the 1st pulse). This strongly depends on the quality of the rising and falling edge of the optical input. The faster the edges the smaller the pulse width variation. Furthermore lower data rates would result in the same issue as all the pulse become 1st pulses
8. The AFBR-24x8xZ is an inverting receiver, hence a logic high at the input (light on) causes a logic low at the electrical data output. Respectively, a rising input edge causes a falling output edge and vice versa.

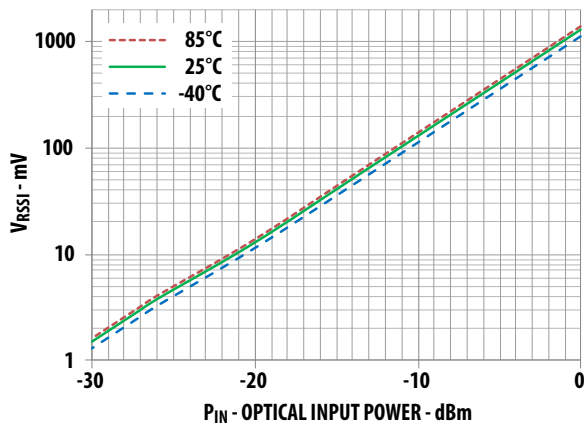

Figure 1. Typical RSSI output voltage across R<sub>RSSI</sub> = 2 kΩ

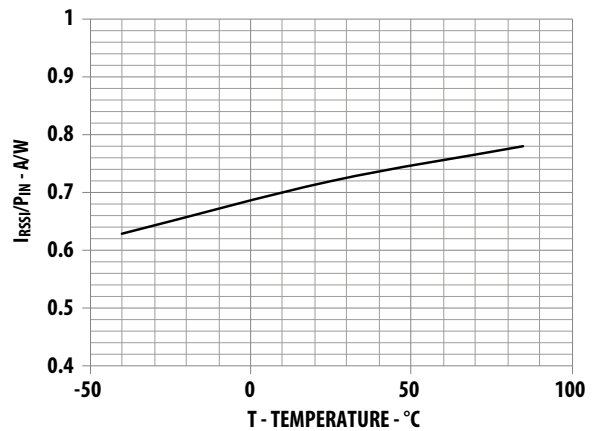

Figure 2. Typical Responsivity vs. Temperature

Note:

To provide a suitable monitoring voltage, choose the value of R<sub>RSSI</sub> according to the particular optical power situation. For the characterization of the responsivity, 2 kΩ was used. The lower the power, the higher the resistor value should be. Do not, however, override the max. limit of V<sub>RSSI</sub>.

## Pin Description

Pin	Name	Function	Notes
1	NC	NC	1
2	/DO	Data Out inverted (CMOS/TTL logic)	2
3	VCC	5V/3.3V Supply Voltage	
4	NC	NC	1
5	NC	NC	1
6	RSSI	Received Signal Strength Indicator Output	
7	GND	Ground	
8	NC	NC	1

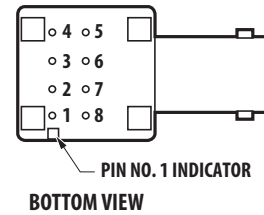

### Notes

- Pins 1, 4, 5 and 8 are connected together internally. The metal port option components (suffix MZ) have an internal electrical connection between the metal port and the four grounding pins
- The data output provides an inverted signal, thus an electrical low in case of light on and vice versa.

## Recommended Circuitry

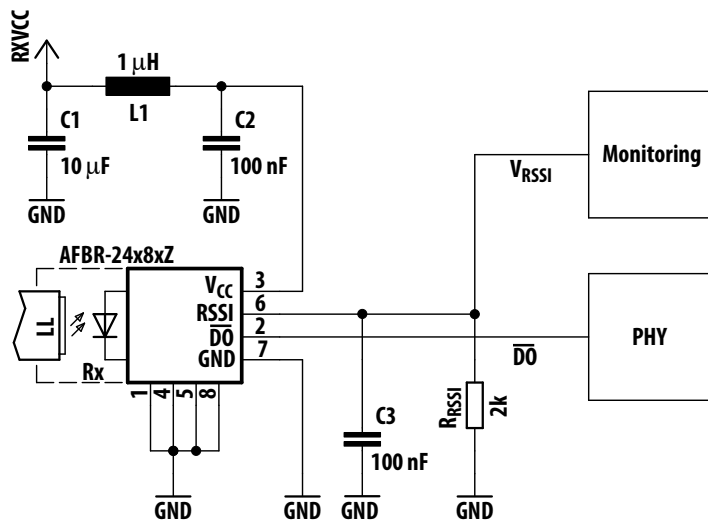

## Recommended Transmitter Driver Circuitry for AFBR-24x8xZ receivers using HFBR-14x4xxZ

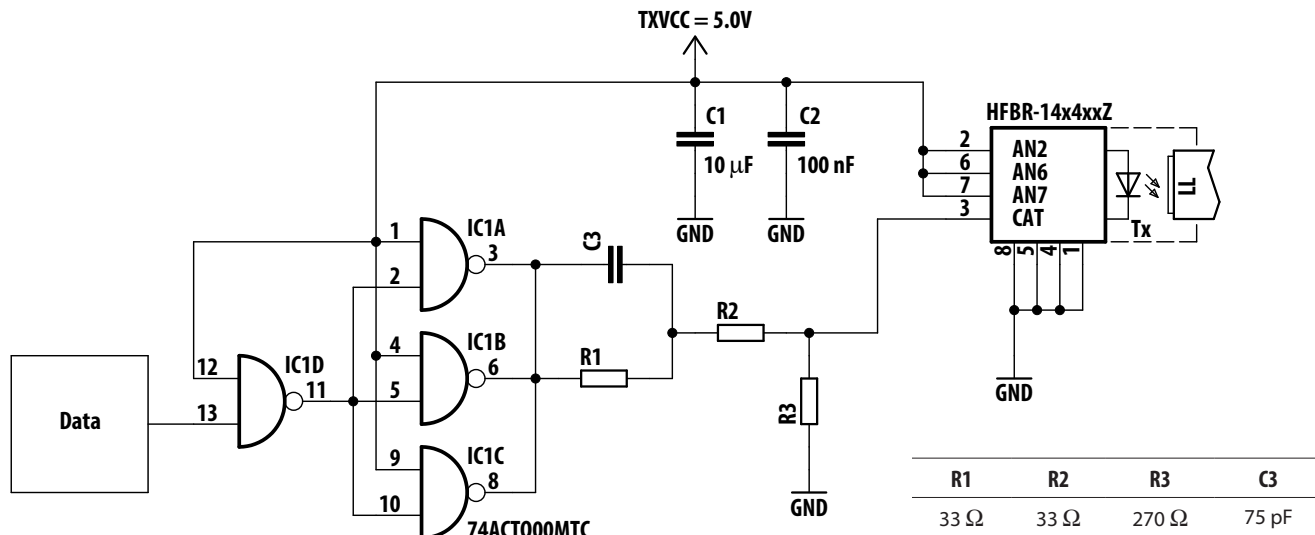

## Mechanical Dimensions – SMA Port

### AFBR-2408Z

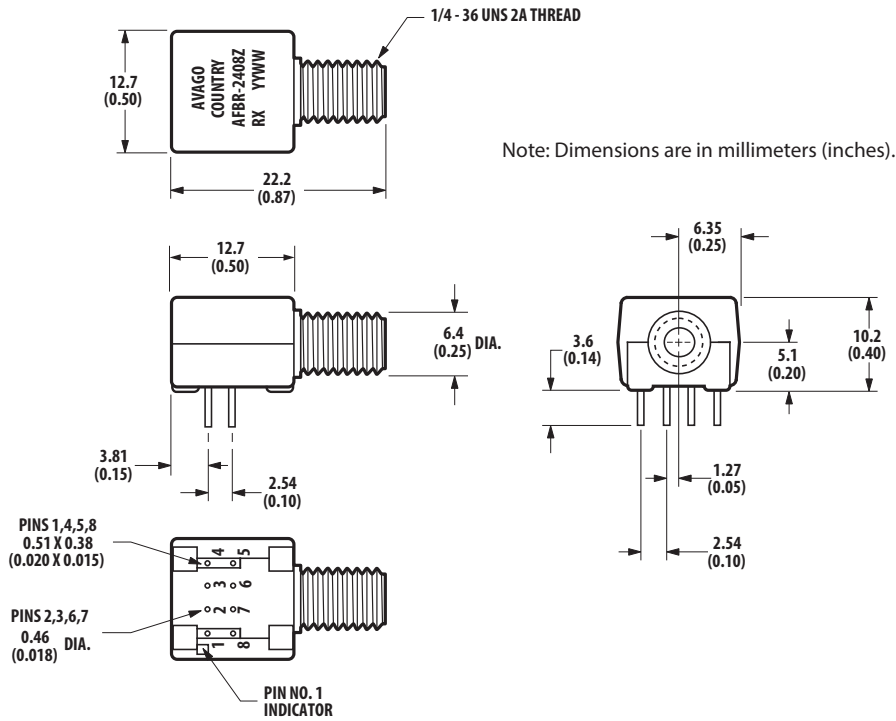

## Mechanical Dimensions – ST Port

### AFBR-2418Z

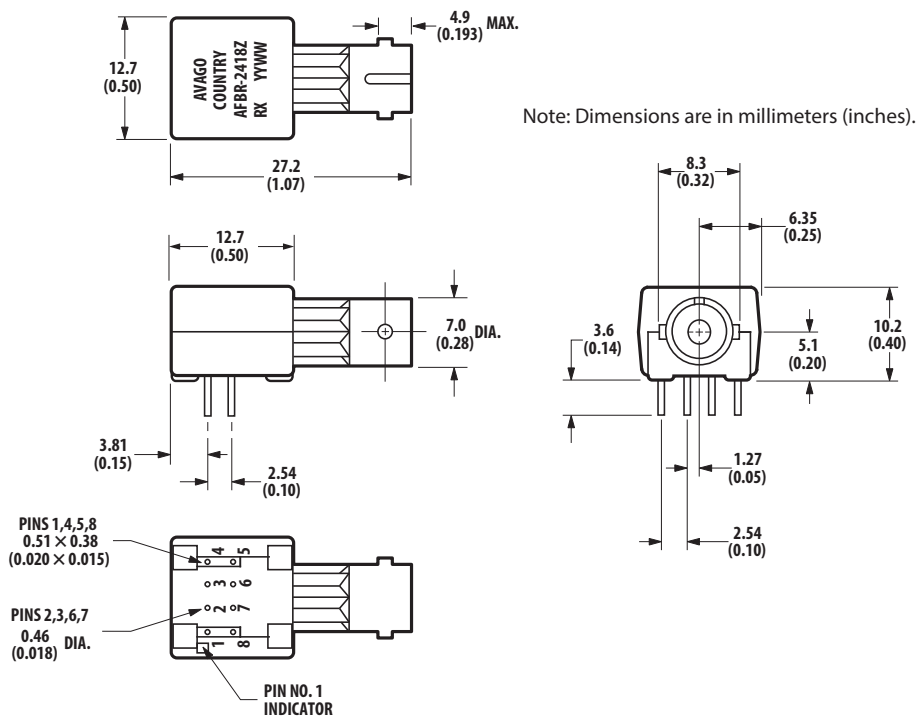

## Mechanical Dimensions – Threaded ST Port

### AFBR-2418TZ

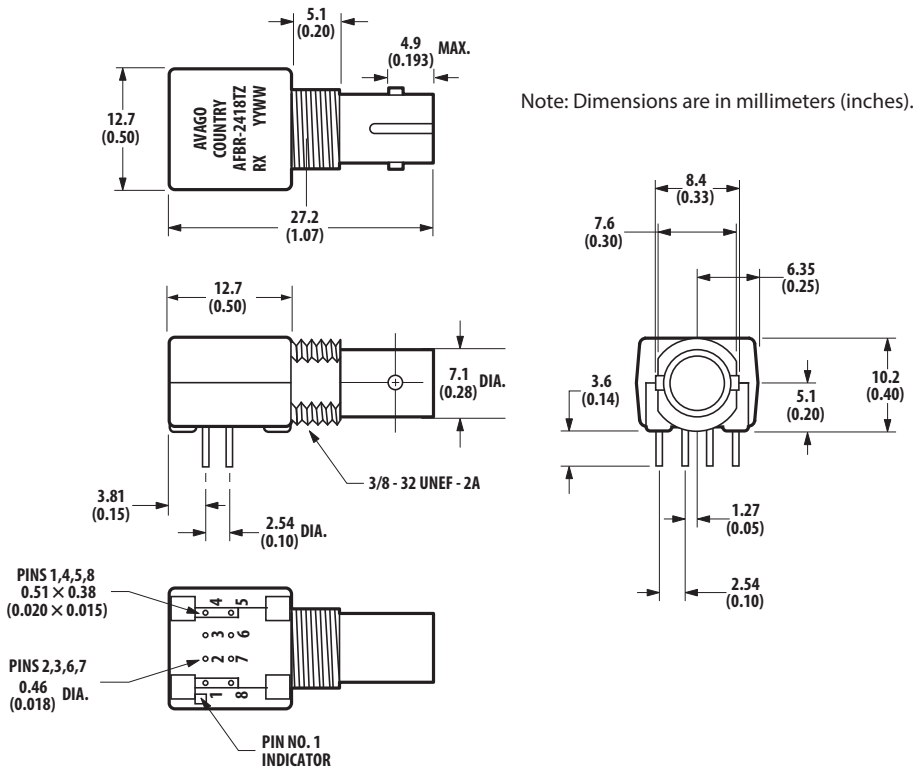

## Mechanical Dimensions – Metal ST Port

### AFBR-2418MZ

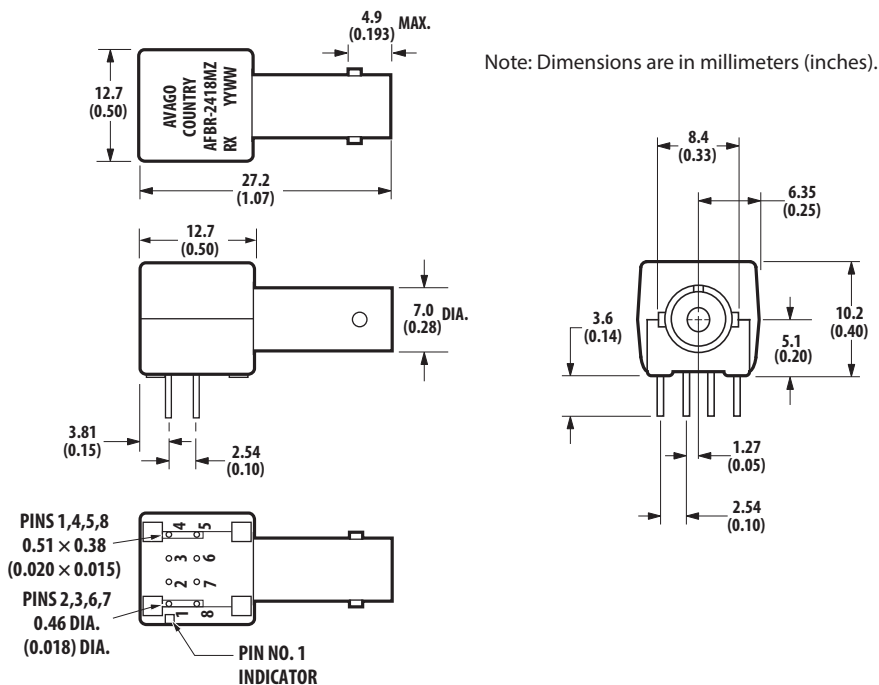

For product information and a complete list of distributors, please go to our web site: [www.avagotech.com](http://www.avagotech.com)

Avago, Avago Technologies, and the A logo are trademarks of Avago Technologies in the United States and other countries. Data subject to change. Copyright © 2005-2013 Avago Technologies. All rights reserved. AV02-4303EN - October 11, 2013

**AVAGO**  
TECHNOLOGIES

## Looking for pricing, stock, or lifecycle information?

Click below to explore more details on WIN SOURCE:

- ⊖ [View 204-125ST](#) on WIN SOURCE
- ⊖ [CTS Electrocomponents](#) Information

## Optimize Your Supply Chain with WIN SOURCE Solutions

- ✓ Global Sourcing Solution
- ✓ Obsolete Management
- ✓ Cost Control Management
- ✓ Shortage Management
- ✓ Alternative Solution
- ✓ Excess Inventory Management