



THE DATASHEET OF
2013298-1



THIS DRAWING IS UNPUBLISHED. RELEASED FOR PUBLICATION SEP ,2007.
 © COPYRIGHT 2007 By - ALL RIGHTS RESERVED.

| LOC | DIST | REVISIONS | | | |
|-----|------|---------------------------|-----------|-----|------|
| P | LTR | DESCRIPTION | DATE | DWN | APVD |
| J | / | | | | |
| | D | REVISED PER ECR-12-004002 | 01MAR2012 | W.W | C.W |

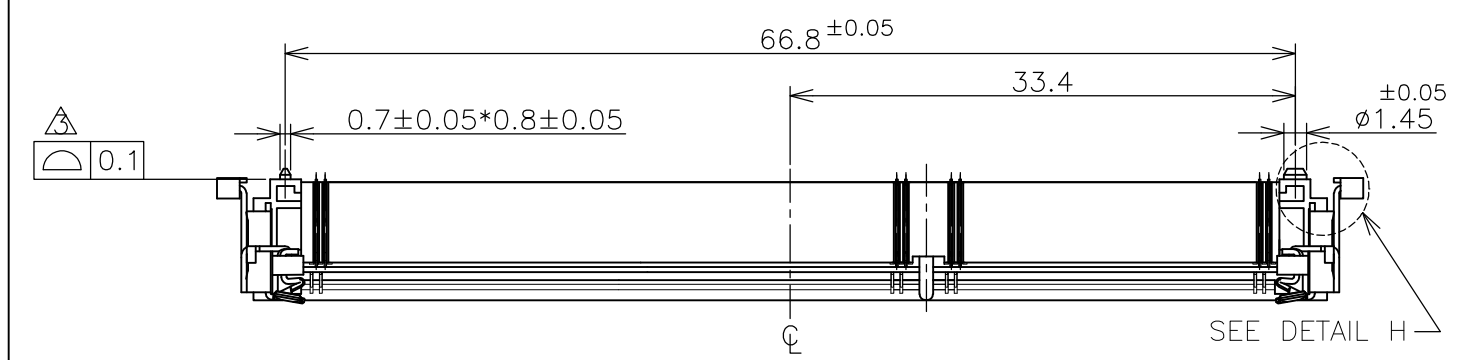

HOW TO MATE AND UNMATE

- MATE: ① → ④
- UNMATE: ⑤ → ⑦

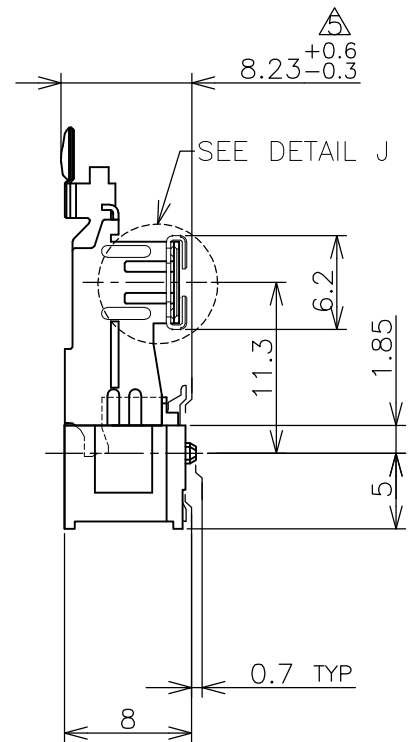
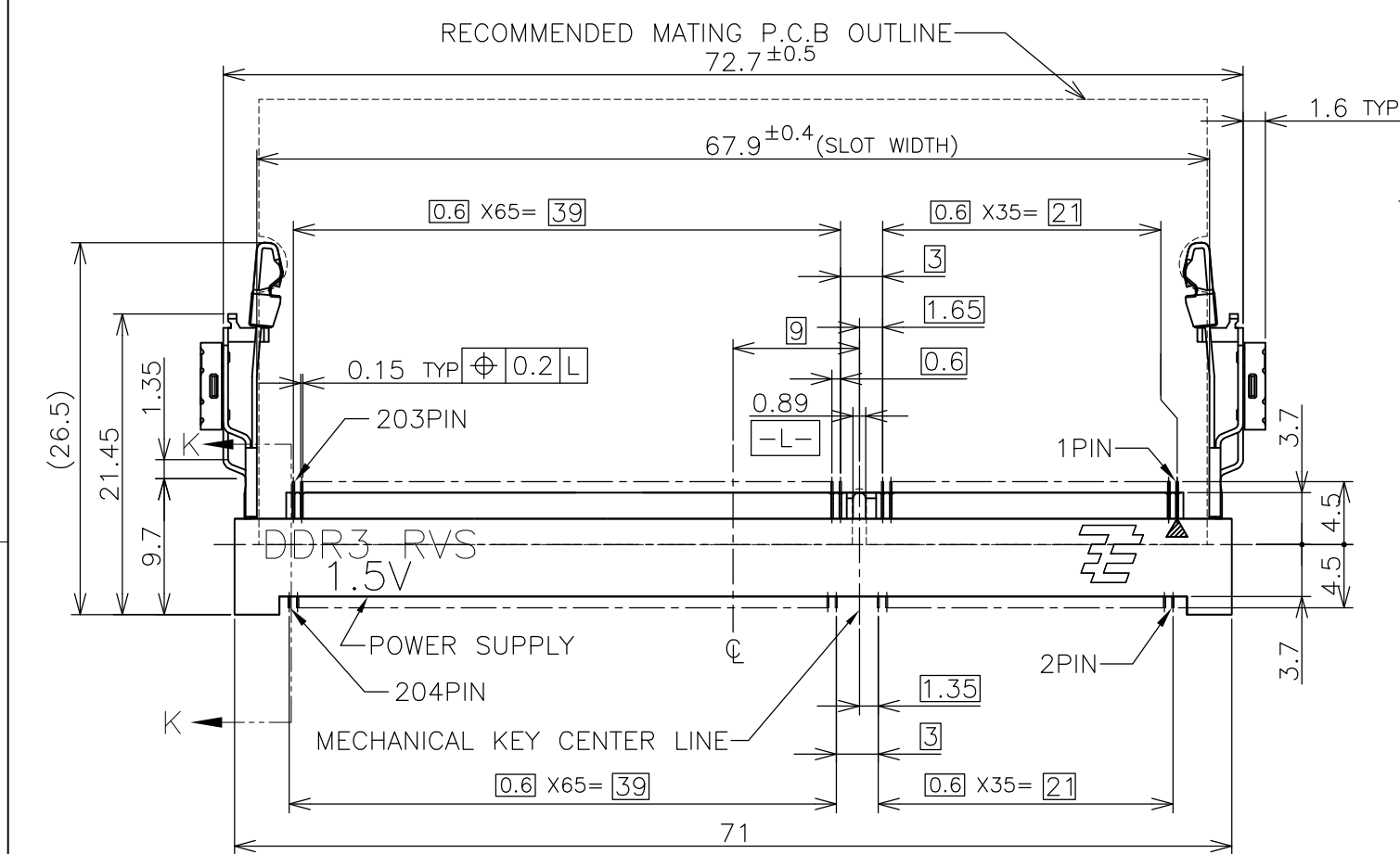
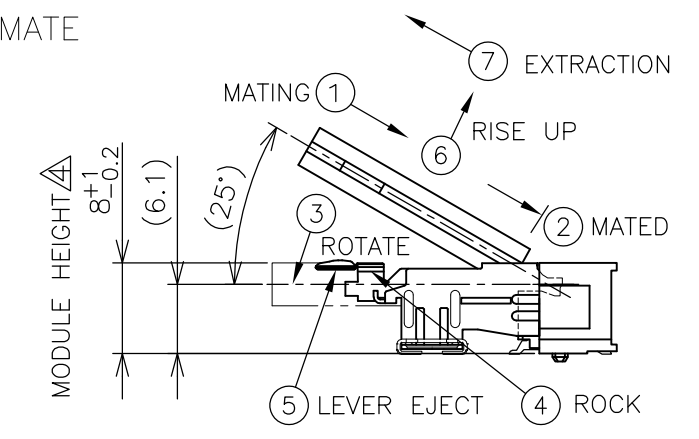

SEE DETAIL J (APPLIED TO SHEET 1-3)

- 1. MATERIAL ; HOUSING: HIGH TEMPERATURE THERMO PLASTIC UL94V-0
 COLOR: SEE TABLE
 CONTACT: COPPER ARROY
 LOCK LEVER: STAINLESS STEEL
 PEG: COPPER ARROY
- 2-1. FINISH ; CONTACT AREA: GOLD FLASH
 ALL OVER NICKEL.
 SOLDERING AREA: GOLD FLASH PLATING
 PEG: TIN PLATING.
- 2-2. FINISH ; CONTACT AREA: 0.000254MIN GOLD
 ALL OVER NICKEL.
 SOLDERING AREA: GOLD FLASH PLATING
 PEG: TIN PLATING.
- 2-3. FINISH ; CONTACT AREA: 0.00076MIN GOLD
 ALL OVER NICKEL.
 SOLDERING AREA: GOLD FLASH PLATING
 PEG: TIN PLATING.

- △ COPLANARITY: 0.1 MAX. (BEFORE SOLDERING)
- △ THE FLOATING VALUE BY SOLDERING IS NOT INCLUDED.
- △ NOT MATING CONDITION.

6. IF THE MODULE DOESN'T INSERT AND LOCK IN THE LATCH SMOOTHLY, OPEN WIDE BOTH LATCHES BY MANUAL. AND THE MODULE MUST BE INSERTED AND LOCKED IN THE LATCH.

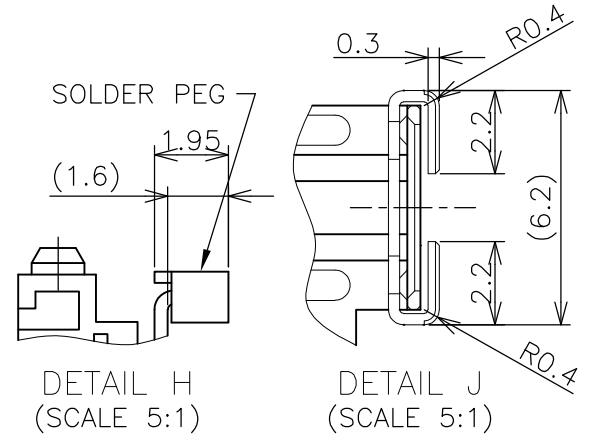
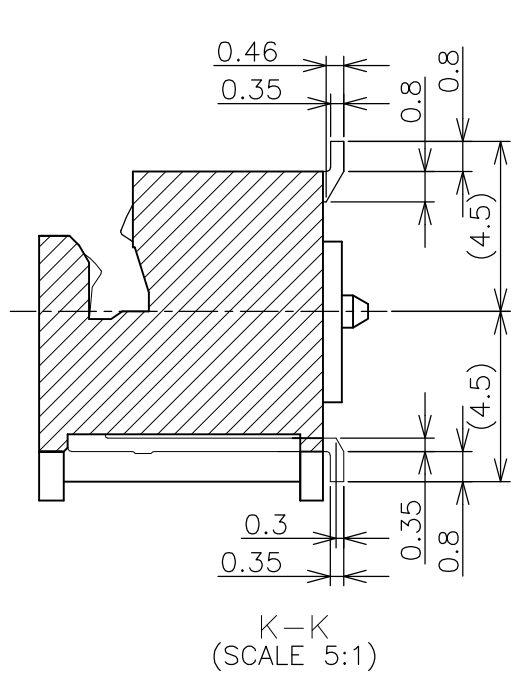

GENERAL TOLERANCE
 10 ≥ ±0.2
 30 ≥ >10: ±0.25
 100 ≥ >30: ±0.3
 ANGLES: ±3°

| | | | | | |
|--|--|---|-----------------|--|--|
| THIS DRAWING IS A CONTROLLED DOCUMENT. | | DWN T.FUMIKURA 18SEP2007 | TE Connectivity | | |
| DIMENSIONS: MM | | CHK K.IKEGAMI 18SEP2007 | | | |
| TOLERANCES UNLESS OTHERWISE SPECIFIED: | | APVD K.IKEGAMI 18SEP2007 | NAME | | |
| 0 PLC ± | | 108-78493 | | | |
| 1 PLC ± | | PRODUCT SPEC | | | |
| 2 PLC ± | | APPLICATION SPEC | | | |
| 3 PLC ± | | SIZE CAGE CODE DRAWING NO RESTRICTED TO | | | |
| 4 PLC ± | | WEIGHT 5.8g A300779 C-2013298 | | | |
| ANGLES ± | | CUSTOMER DRAWING SCALE 2:1 SHEET 1 OF 6 REV D | | | |
| FINISH | | | | | |

4

3

2

1

THIS DRAWING IS UNPUBLISHED.

RELEASED FOR PUBLICATION SEP , 2007.

© COPYRIGHT 2007 By -

ALL RIGHTS RESERVED.

LOC
J

DIST
/

REVISIONS

| P | LTR | DESCRIPTION | DATE | DWN | APVD |
|---|-----|-------------|------|-----|------|
| - | - | SEE SHEET 1 | - | - | - |

| | | | | | | | |
|----------------|------------------------------|-----------|---------------|----------|--------------|-----|-------------|
| AVAILABLE | ENBOSS (SEE SHEET 6) | WITHBOSS | BLACK | NOTE 2-3 | 1.5V | 204 | 2-2013298-3 |
| AVAILABLE | ENBOSS (SEE SHEET 6) | WITHBOSS | BLACK | NOTE 2-2 | 1.5V | 204 | 2-2013298-2 |
| AVAILABLE | ENBOSS (SEE SHEET 6) | WITHBOSS | BLACK | NOTE 2-1 | 1.5V | 204 | 2-2013298-1 |
| AVAILABLE | SEMI-HARD TRAY (SEE SHEET 5) | WITH BOSS | BLACK | NOTE 2-3 | 1.5V | 204 | 2013298-3 |
| AVAILABLE | SEMI-HARD TRAY (SEE SHEET 5) | WITH BOSS | BLACK | NOTE 2-2 | 1.5V | 204 | 2013298-2 |
| AVAILABLE | SEMI-HARD TRAY (SEE SHEET 5) | WITH BOSS | BLACK | NOTE 2-1 | 1.5V | 204 | 2013298-1 |
| TOOLING STATUS | PACKAGING TYPE | REMARK | HOUSING COLOR | FINISH | POWER SUPPLY | POS | PART NO. |

THIS DRAWING IS A CONTROLLED DOCUMENT.

DIMENSIONS:

MM

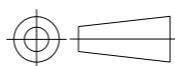

TOLERANCES UNLESS OTHERWISE SPECIFIED:

0 PLC ± 0.5
 1 PLC ± 0.5
 2 PLC ± 0.5
 3 PLC ± 0.5
 4 PLC ± 0.5
 ANGLES ± 3'

MATERIAL

FINISH

DWN
 CHK
 APVD
 PRODUCT SPEC
 APPLICATION SPEC
 WEIGHT



NAME
 DDR3 SODIMM SOCKET
 0.6mm PITCH 204POS
 8.0mm HEIGHT REVERSE TYPE

| | | | |
|------|-----------|------------|---------------|
| SIZE | CAGE CODE | DRAWING NO | RESTRICTED TO |
| A3 | 00779 | C-2013298 | - |

CUSTOMER DRAWING

SCALE 2:1

SHEET 2 OF 6

REV D

THIS DRAWING IS UNPUBLISHED. RELEASED FOR PUBLICATION SEP ,2007.
 © COPYRIGHT 2007 By - ALL RIGHTS RESERVED.

| LOC | | DIST | | REVISIONS | | |
|-----|-----|-------------|------|-----------|------|--|
| P | LTR | DESCRIPTION | DATE | DWN | APVD | |
| J | / | SEE SHEET 1 | - | - | - | |

REFERENCE P.C.BOARD PATTERN LAYOUT (CONNECTOR MOUNTING SIDE)

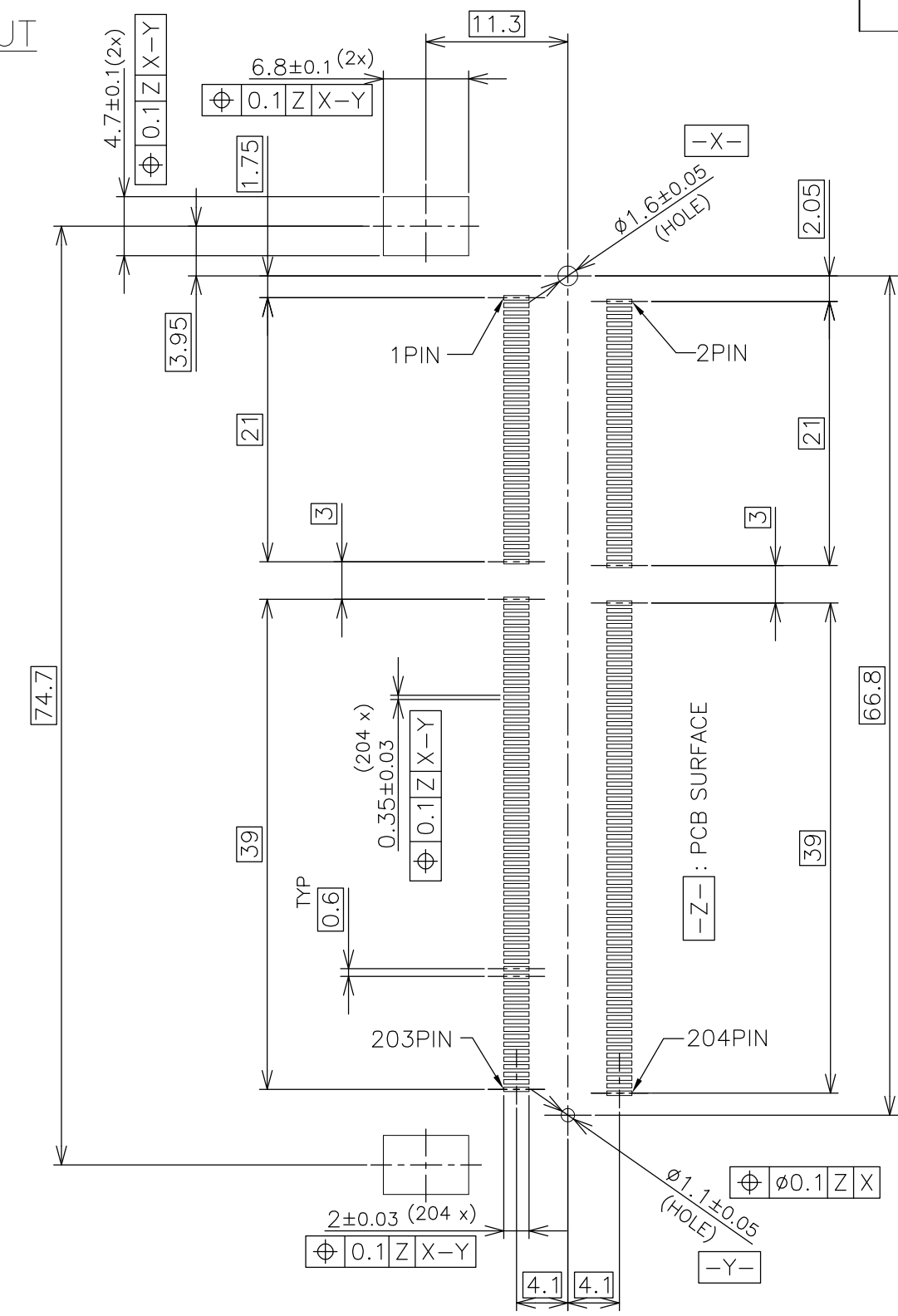

RVS TYPE

| | | | | | |
|--|--|------------------|--|---------------------------|-----------|
| THIS DRAWING IS A CONTROLLED DOCUMENT. | | DWN | | TE Connectivity | |
| DIMENSIONS: MM | | CHK | | | |
| | | APVD | | NAME | |
| TOLERANCES UNLESS OTHERWISE SPECIFIED: | | PRODUCT SPEC | | DDR3 SODIMM SOCKET | |
| 0 PLC ± | | APPLICATION SPEC | | 0.6mm PITCH 204POS | |
| 1 PLC ± | | WEIGHT | | 8.0mm HEIGHT REVERSE TYPE | |
| 2 PLC ± | | CUSTOMER DRAWING | | SIZE | CAGE CODE |
| 3 PLC ± | | SCALE 2:1 | | A3 | 00779 |
| 4 PLC ± | | SHEET 3 OF 6 | | DRAWING NO | C-2013298 |
| ANGLES ± | | REV D | | RESTRICTED TO | |
| FINISH | | | | | |

THIS DRAWING IS UNPUBLISHED. RELEASED FOR PUBLICATION SEP ,2007.
 © COPYRIGHT 2007 By - ALL RIGHTS RESERVED.

| LOC | | DIST | | REVISIONS | | | |
|-----|-----|-------------|-------------|-----------|------|---|--|
| P | LTR | DESCRIPTION | DATE | DWN | APVD | | |
| J | / | - | SEE SHEET 1 | - | - | - | |

REFERENCE MATING P.C.B CONFIGURATION

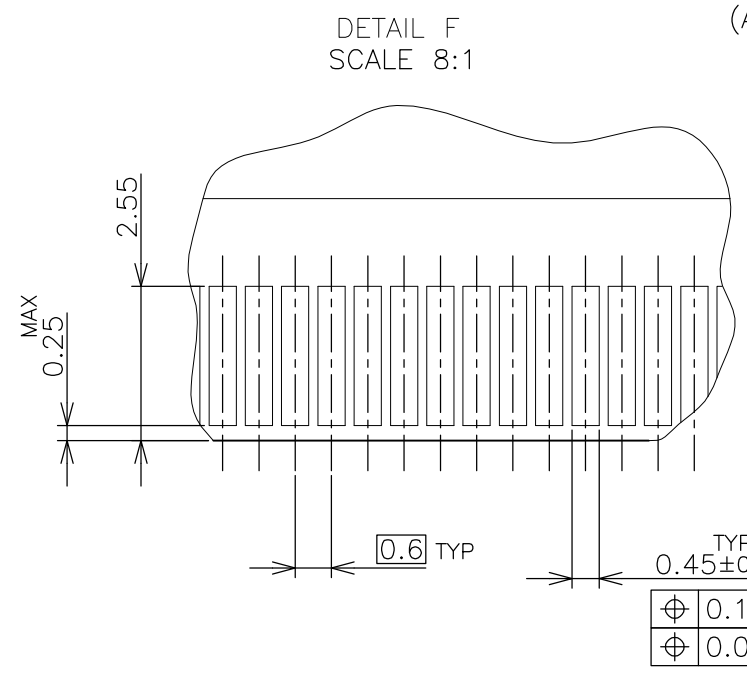
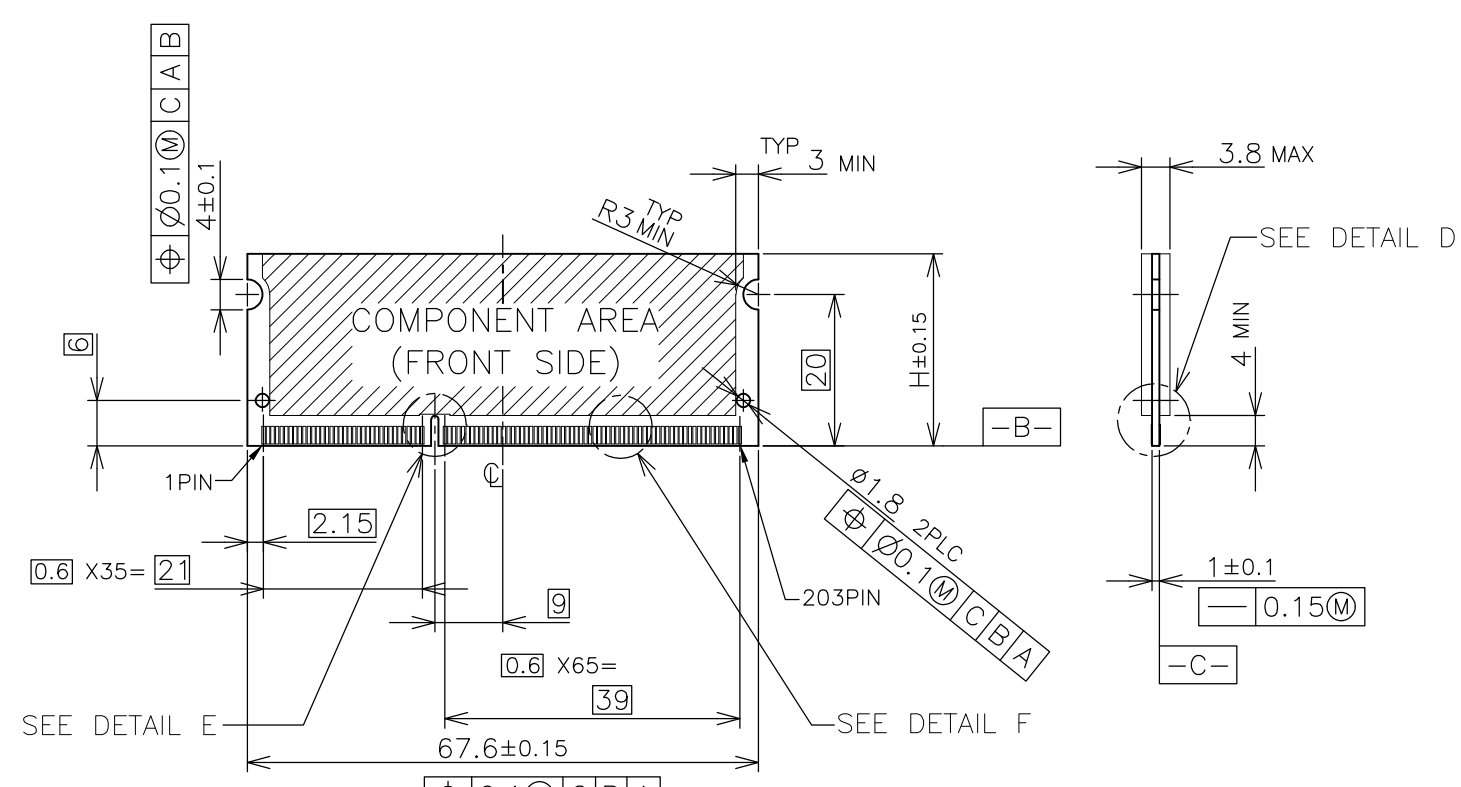

- (APPLIED TO SHEET 4)
1. TOLERANCES ON ALL DIMENSIONS ±0.15 UNLESS OTHERWISE SPECIFIED.
 2. P.C. BOARD THICKNESS APPLIES ACROSS TABS AND INCLUDES PLATING AND/OR METALIZATION.
 3. FINISH OF PAD : GOLD PLATING 0.00076 MIN. OVER Ni PLATING 0.002MIN.
- NO BURR
 CHAMFER 0.25 MAX x 45° IF EXIST.

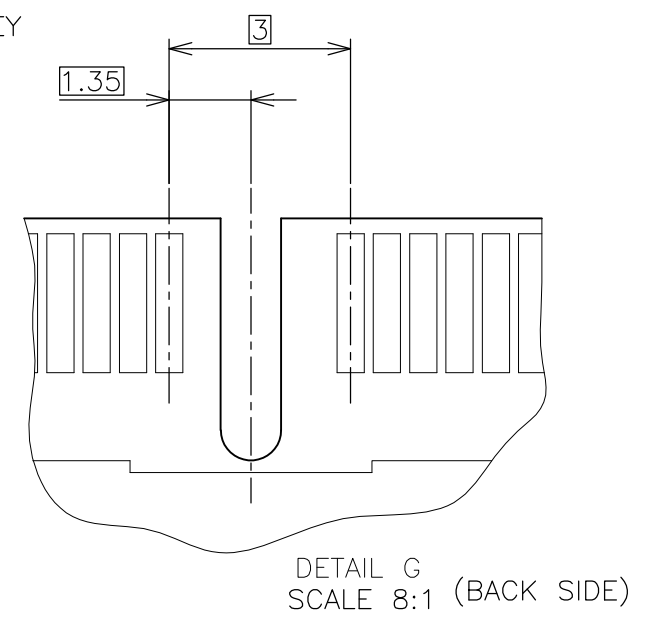
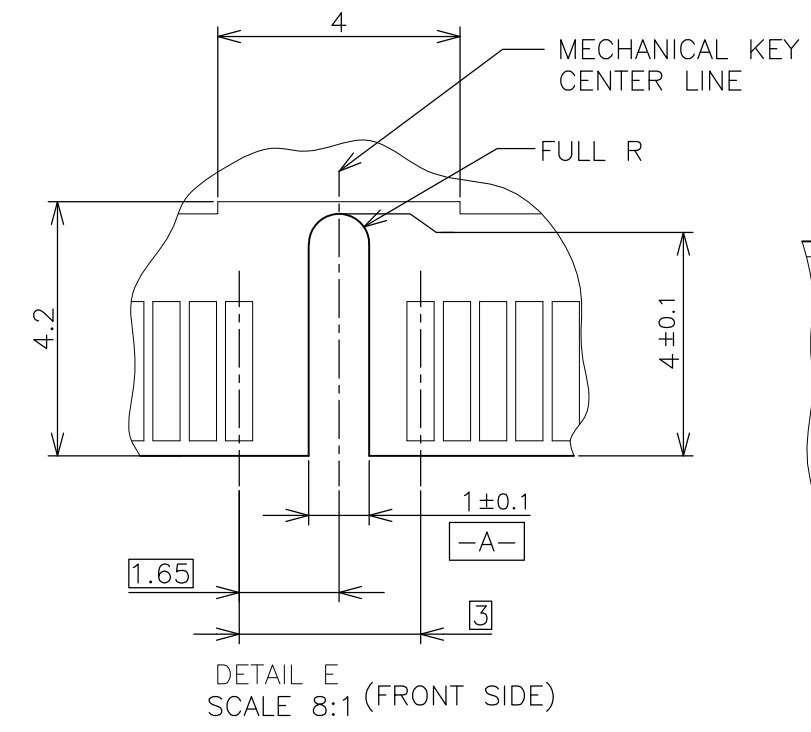
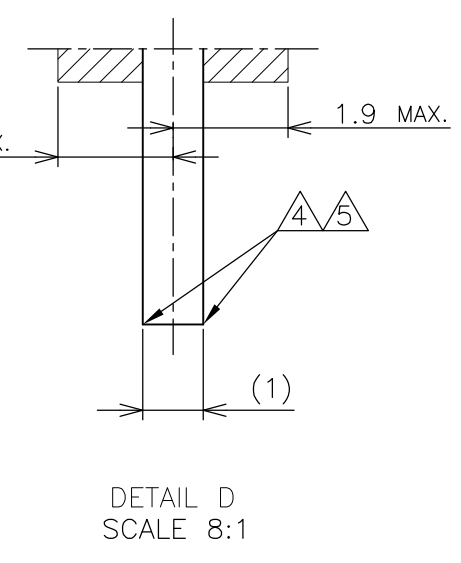
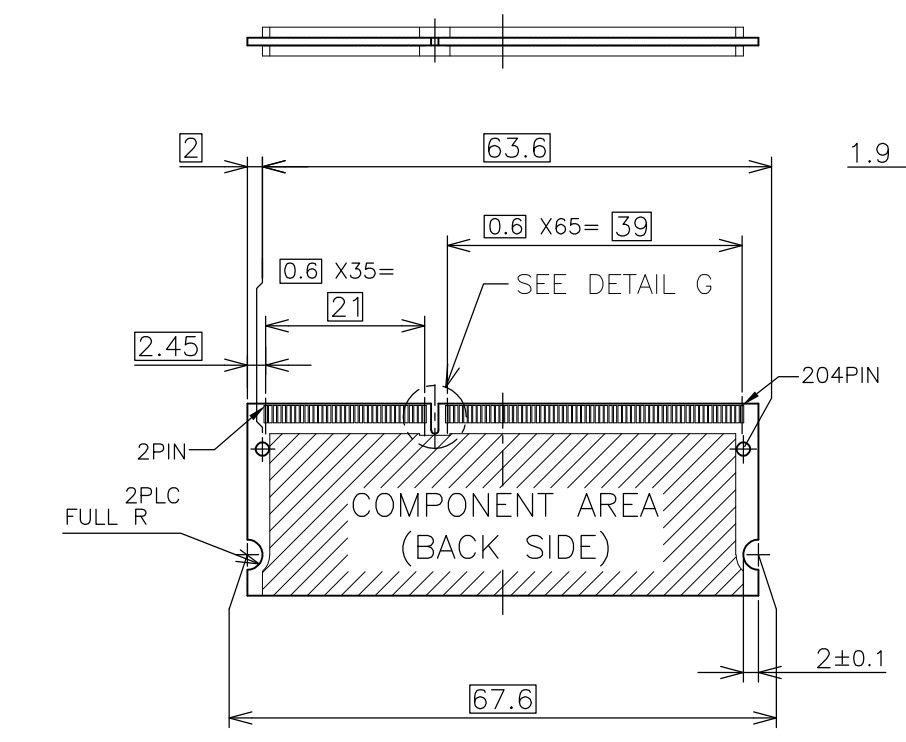

| | |
|-------|------------------|
| 30 | CA |
| 31.75 | BA |
| 25.4 | AA |
| H | SDRAM VARIATIONS |

| | | | | | |
|---|--|------------------|--|-----------|------------|
| THIS DRAWING IS A CONTROLLED DOCUMENT. | | DWN | TE Connectivity DDR3 SODIMM SOCKET 0.6mm PITCH 204POS 8.0mm HEIGHT REVERSE TYPE | | |
| DIMENSIONS: MM | | CHK | | | |
| TOLERANCES UNLESS OTHERWISE SPECIFIED: | | APVD | | | |
| 0 PLC ± 1 PLC ± 2 PLC ± 3 PLC ± 4 PLC ± ANGLES ± FINISH ± | | NAME | | | |
| MATERIAL | | PRODUCT SPEC | A300779 C-2013298 | | |
| | | APPLICATION SPEC | SIZE | CAGE CODE | DRAWING NO |
| | | WEIGHT | RESTRICTED TO | | |
| | | CUSTOMER DRAWING | SCALE | SHEET | REV |

4

3

2

1

THIS DRAWING IS UNPUBLISHED. RELEASED FOR PUBLICATION SEP ,2007.
 © COPYRIGHT 2007 By - ALL RIGHTS RESERVED.

| LOC | DIST | REVISIONS | | | |
|-----|------|-------------|------|-----|------|
| P | LTR | DESCRIPTION | DATE | DWN | APVD |
| | - | SEE SHEET 1 | - | - | - |

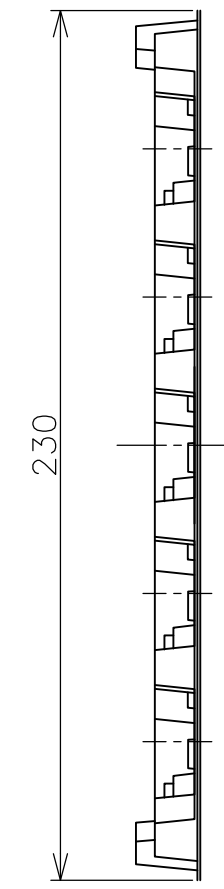
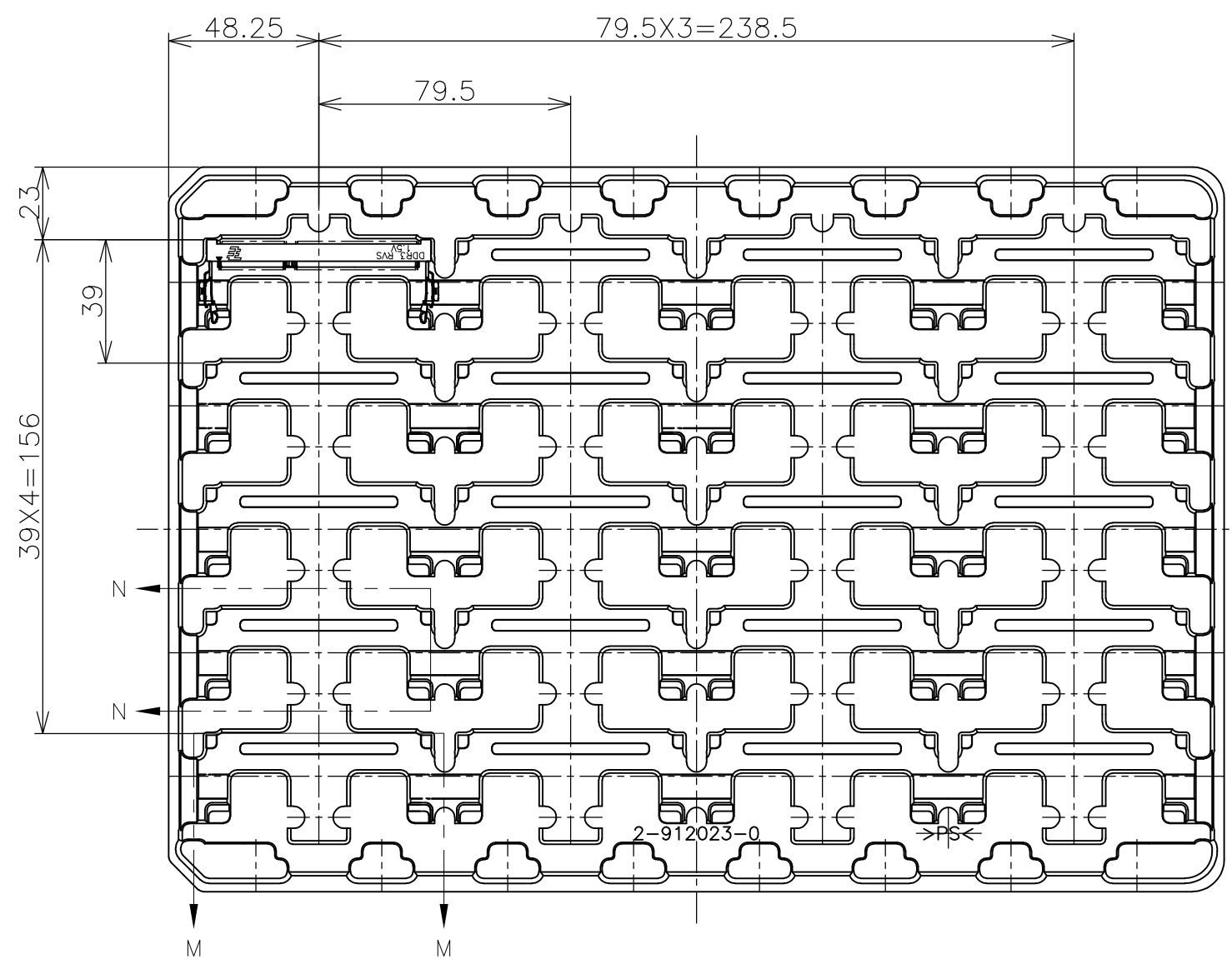

- (APPLIED TO SHEET 5)
1. THE DIRECTION OF EACH CONNECTOR ON A TRAY IS REFERRED TO THIS DRAWING.
 2. GENERAL TOLERANCE: ± 0.5 , $\pm 3^\circ$

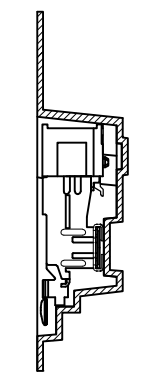

N-N
SCALE 1:1

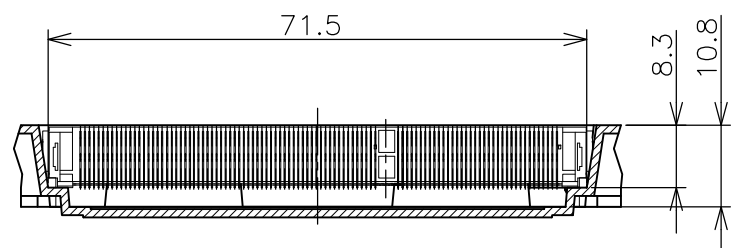
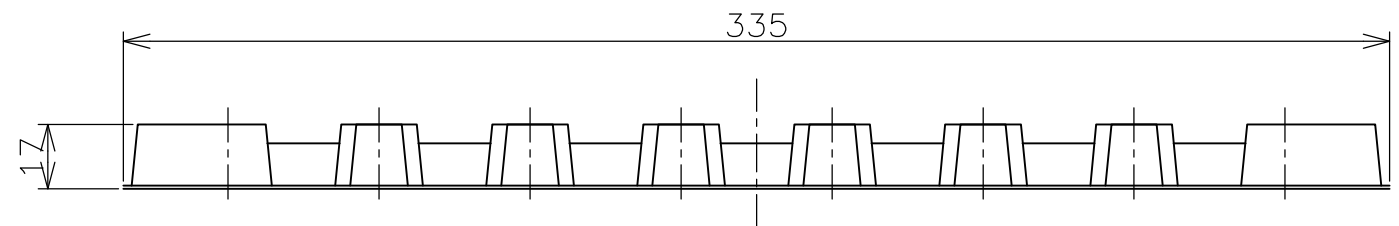

M-M
SCALE 1:1
(180DEG. ROTATE)

| | | |
|---------|----------|-------------|
| 200EA | 20EA | *-2013298-* |
| QTY/BOX | QTY/TRAY | PART NO. |

| | | | | | |
|--|--|------------------|--|---------------------------|--|
| THIS DRAWING IS A CONTROLLED DOCUMENT. | | DWN | | TE Connectivity | |
| DIMENSIONS: MM | | CHK | | | |
| TOLERANCES UNLESS OTHERWISE SPECIFIED: | | APVD | | NAME | |
| 0 PLC ± 0.5 | | PRODUCT SPEC | | DDR3 SODIMM SOCKET | |
| 1 PLC ± 0.5 | | APPLICATION SPEC | | 0.6mm PITCH 204POS | |
| 2 PLC ± 0.5 | | WEIGHT | | 8.0mm HEIGHT REVERSE TYPE | |
| 3 PLC ± 0.5 | | SIZE | | DRAWING NO | |
| 4 PLC ± 0.5 | | CAGE CODE | | RESTRICTED TO | |
| ANGLES $\pm 3^\circ$ | | A300779 | | C-2013298 | |
| FINISH | | CUSTOMER DRAWING | | SCALE 1:2 | |
| | | SHEET 5 OF 6 | | REV D | |

THIS DRAWING IS UNPUBLISHED. RELEASED FOR PUBLICATION SEP ,2007.
 © COPYRIGHT 2007 By -- ALL RIGHTS RESERVED.

| LOC | DIST | REVISIONS | | | |
|-----|------|-------------|------|-----|------|
| P | LTR | DESCRIPTION | DATE | DWN | APVD |
| J | / | SEE SHEET 1 | - | - | - |

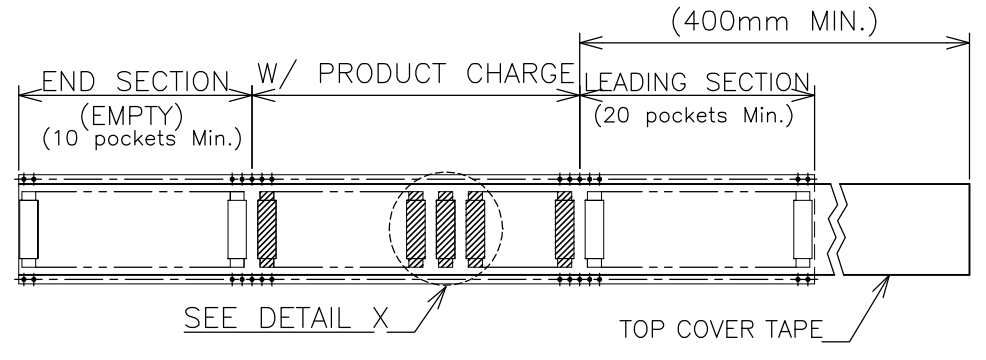
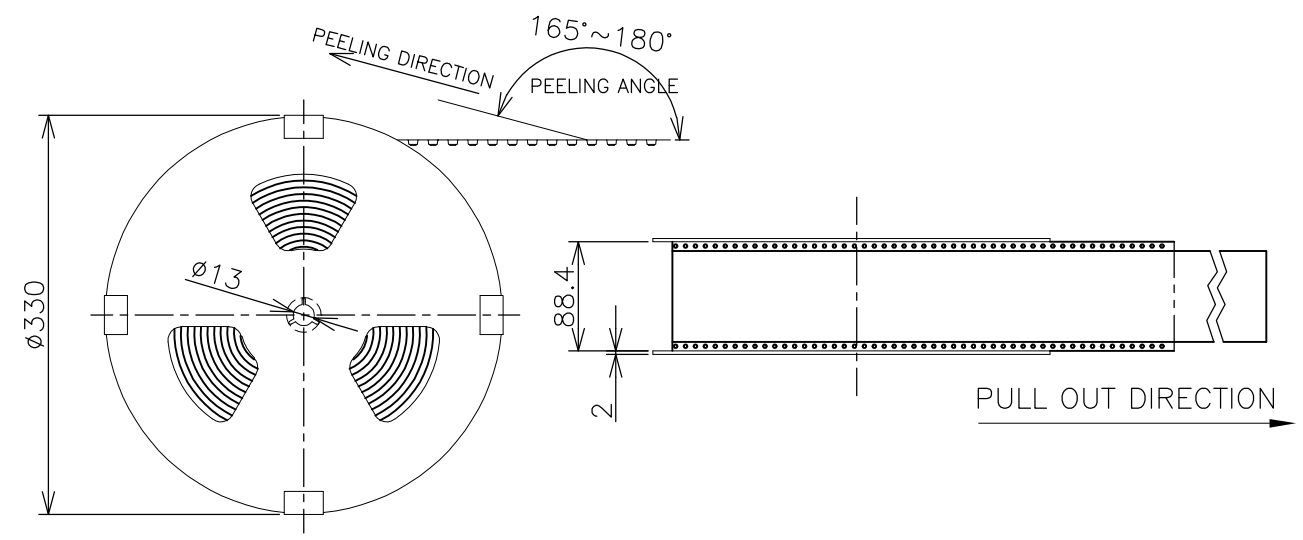

- (APPLIED TO SHEET 6)
1. THE DIRECTION OF EACH CONNECTOR ON A EMBOSS IS REFERRED TO THIS DRAWING.
 2. GENERAL TOLERANCE: ± 0.5 , $\pm 3^\circ$

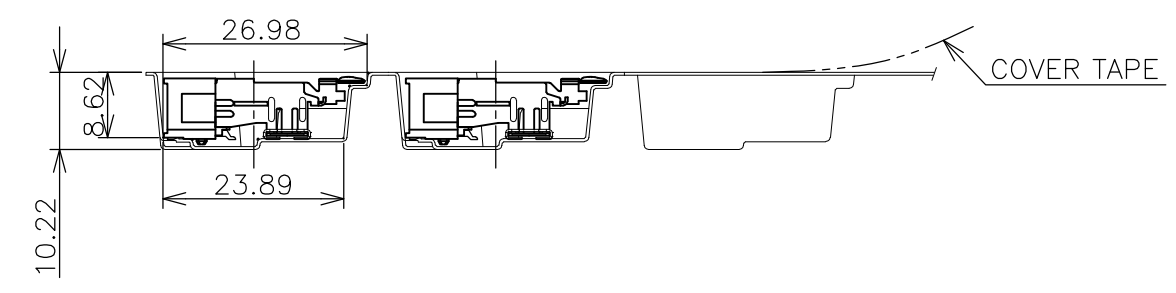
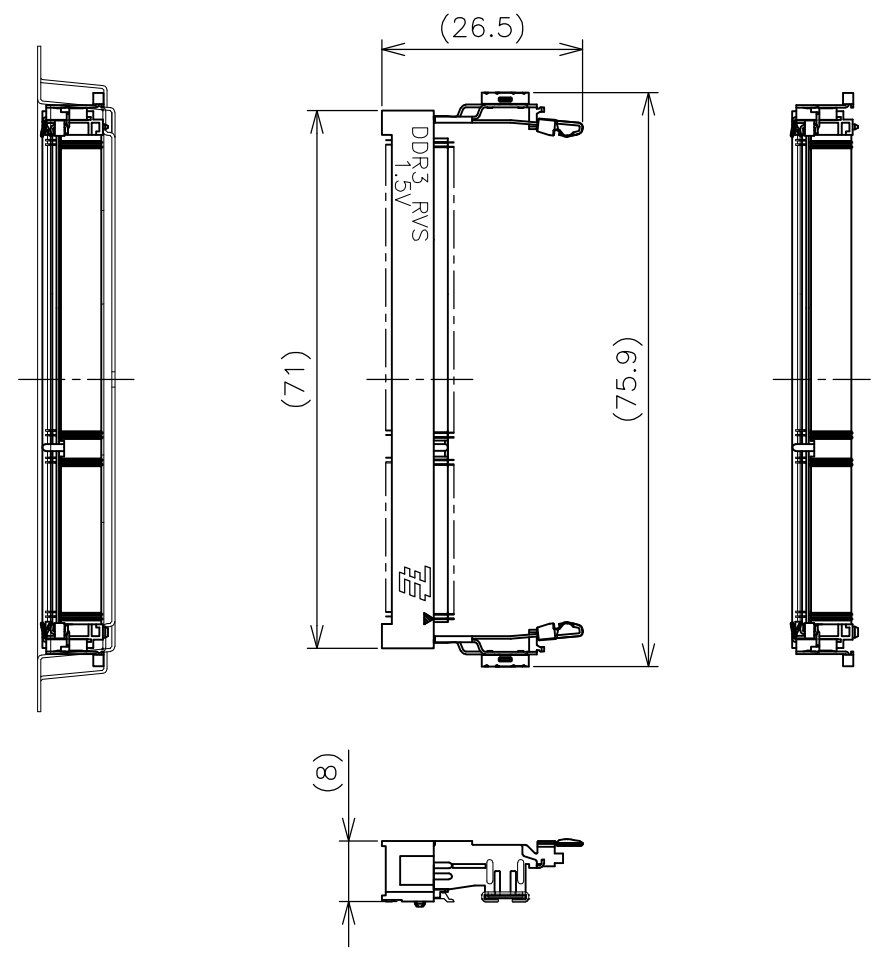
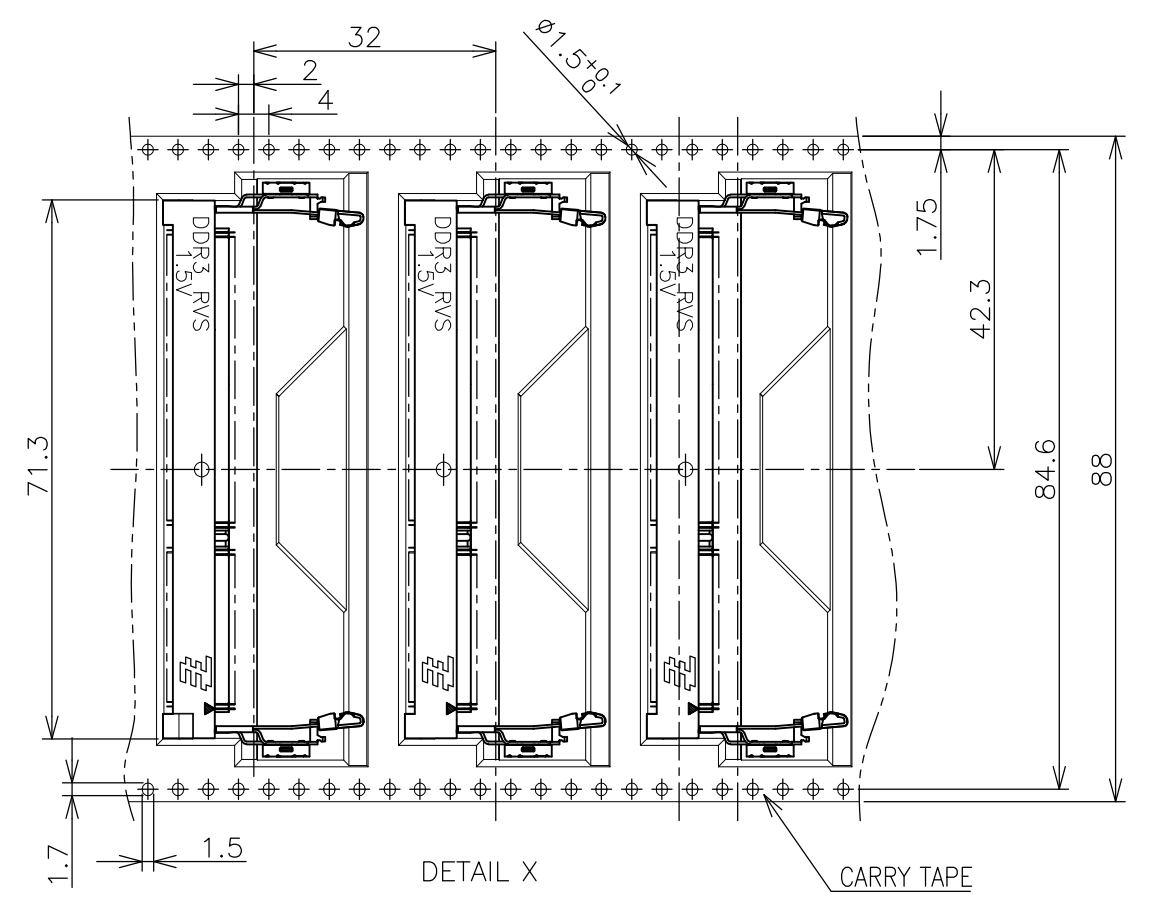

| | | | | | | | | |
|---|--|------------------|--|--|--|---------------|-----------|------------|
| THIS DRAWING IS A CONTROLLED DOCUMENT. | | DWN | TE Connectivity NAME DDR3 SODIMM SOCKET 0.6mm PITCH 204POS 8.0mm HEIGHT REVERSE TYPE | | | | | |
| DIMENSIONS: MM | | CHK | | | | SIZE | CAGE CODE | DRAWING NO |
| TOLERANCES UNLESS OTHERWISE SPECIFIED: | | APVD | | | | A3 | 00779 | C-2013298 |
| MATERIAL | | PRODUCT SPEC | | | | RESTRICTED TO | | |
| 0 PLC ± 0.5 1 PLC ± 0.5 2 PLC ± 0.5 3 PLC ± 0.5 4 PLC ± 0.5 ANGLES $\pm 3^\circ$ | | APPLICATION SPEC | SCALE 1:1 | | | | | |
| FINISH | | WEIGHT | SHEET 6 OF 6 | | | | | |
| | | CUSTOMER DRAWING | REV D | | | | | |

Looking for pricing, stock, or lifecycle information?

Click below to explore more details on WIN SOURCE:

 [View 2013298-1](#) on WIN SOURCE

 [TE Connectivity](#) Information

Optimize Your Supply Chain with WIN SOURCE Solutions

-  Global Sourcing Solution
-  Obsolete Management
-  Cost Control Management
-  Shortage Management
-  Alternative Solution
-  Excess Inventory Management