

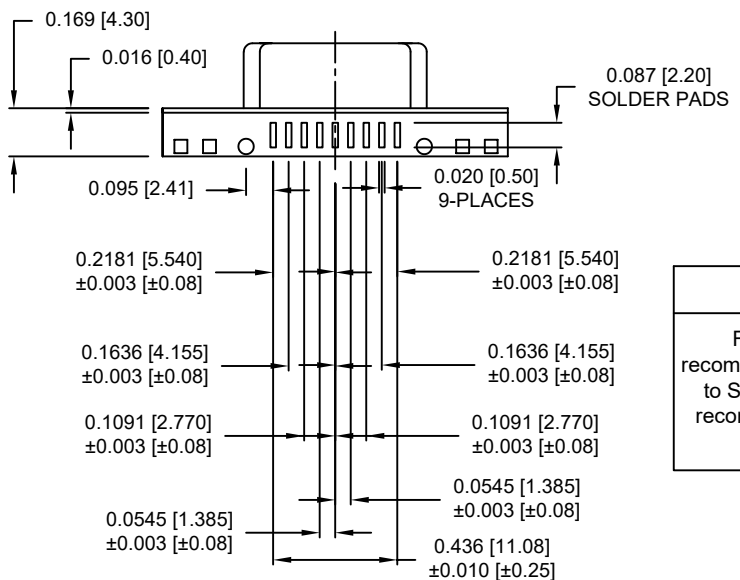

**THE DATASHEET OF**  
**190-009-263R001**

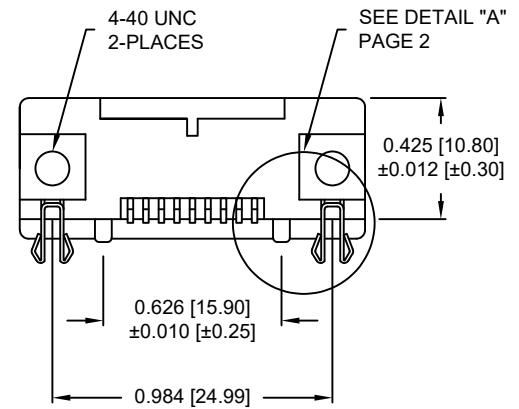

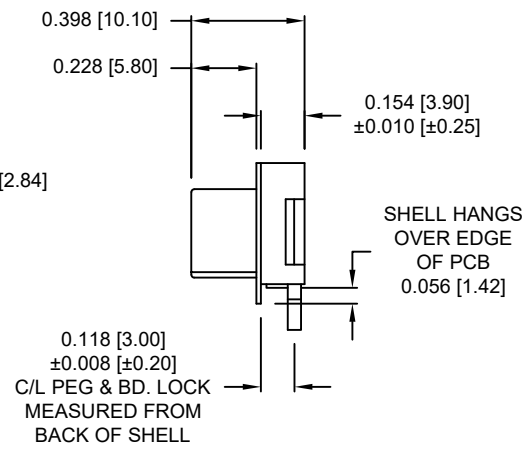
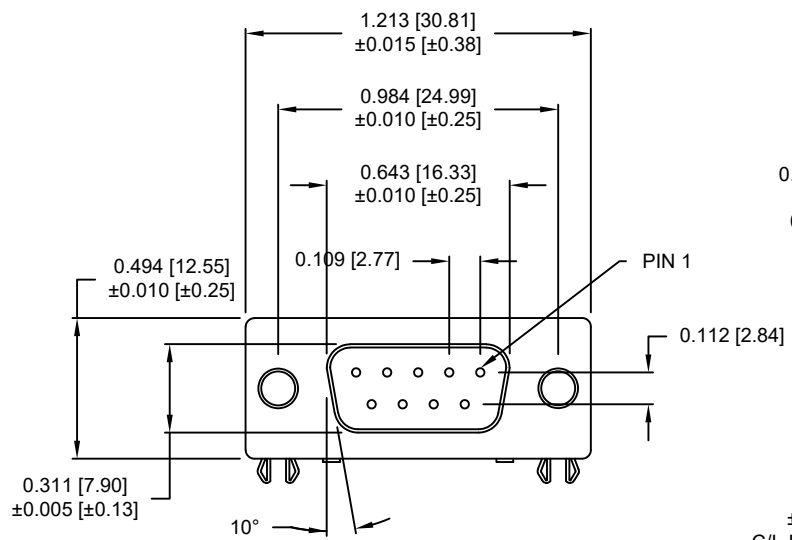

**Storage and Process Instructions:**

For parts exposed to greater than 60% RH, it is recommended parts be baked at 125°C for 3-5 hours prior to SMT reflow process. If unsure of RH exposure, it is recommend to bake at the above temperature and time prior to SMT reflow process.

**SPECIFICATIONS:**

**ELECTRICAL:**

- RATED CURRENT: 5A
- RATED VOLTAGE: 300VDC
- WITHSTANDING VOLTAGE: 500VAC (rms) FOR 1 MIN
- INSULATION RESISTANCE: > 1,000 mΩ at 500VDC
- CONTACT RESISTANCE: 13mOhms MAX
- DIELECTRIC STRENGTH: 1000VAC FOR 1 MIN
- OPERATING TEMPERATURE: -55°C TO +105°C

**MATERIALS:**

- SHELL: NICKEL PLATED STEEL
- BRACKET: NICKEL PLATED STEEL
- INSULATOR: NYLON 6T, UL 94V-0, BLACK
- PROCESS TEMP: 260°C
- INSULATOR: PATONE #322C, COLOR=Pc99
- CONTACT: TIN PLATED PHOSPHOR BRONZE
- GOLD FLASH MATING AREA
- TIN PLATED SOLDER AREA

RoHS COMPLIANT

UNITS = inch [mm]

DO NOT SCALE FROM DRAWING



THESE DRAWINGS AND SPECIFICATIONS ARE THE PROPERTY OF NorComp AND SHALL NOT BE REPRODUCED, COPIED OR USED AS THE BASIS FOR THE MANUFACTURE OR SALE OF APPARATUS WITHOUT WRITTEN PERMISSION.

DRAWN: C. SMITH  
DATE: 03/30/2009

NorComp

SCALE: NTS	SHEET 1 OF 2	REV 15
DWG NO. 190-009-263R001		

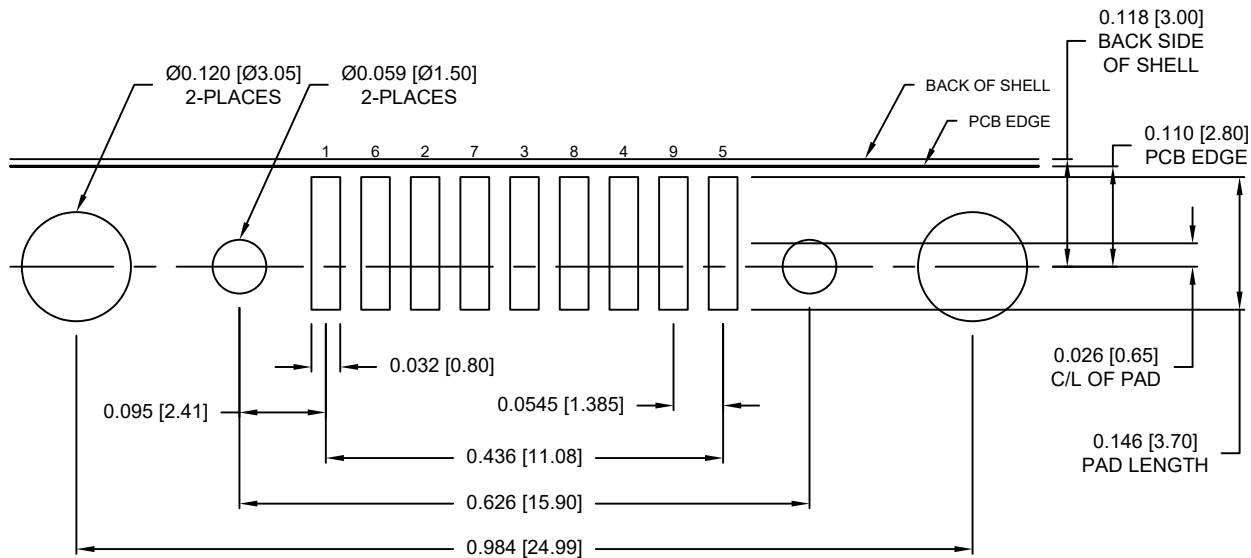

**RECOMMENDED PCB LAYOUT**

CONTACT ARRANGEMENT  
1 6 2 7 3 8 4 9 5

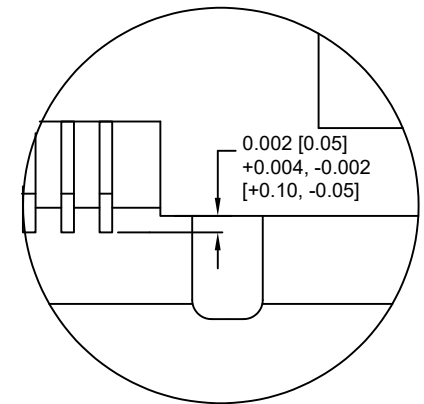

**DETAIL "B"**  
CONTACT COPLANARITY

SEE DETAIL "B"  
FOR CONTACT  
COPLANARITY

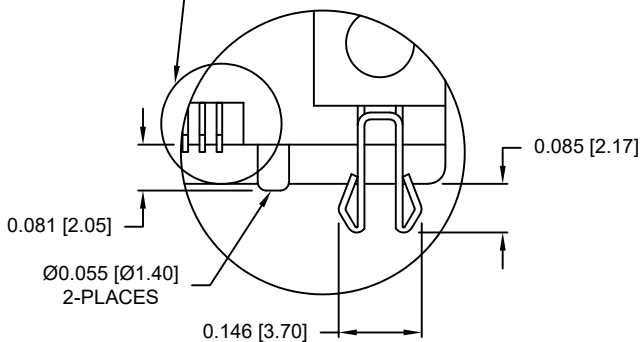

**DETAIL "A"**

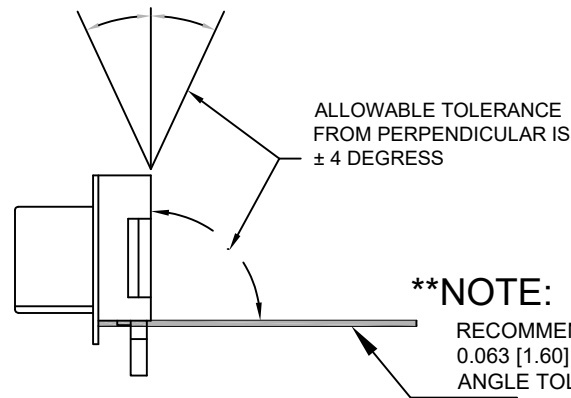

**RoHS COMPLIANT**

UNITS = inch [mm]

**DO NOT SCALE FROM DRAWING**



THESE DRAWINGS AND SPECIFICATIONS ARE THE PROPERTY OF NorComp AND SHALL NOT BE REPRODUCED, COPIED OR USED AS THE BASIS FOR THE MANUFACTURE OR SALE OF APPARATUS WITHOUT WRITTEN PERMISSION.

DRAWN:

C. SMITH

DATE:

03/30/2009

**NorComp**

SCALE:

NTS

SHEET

OF

2

2

REV

15

DWG NO.

190-009-263R001

## Looking for pricing, stock, or lifecycle information?

Click below to explore more details on WIN SOURCE:

 [View 190-009-263R001 on WIN SOURCE](#)

 [NorComp Inc. Information](#)

## Optimize Your Supply Chain with WIN SOURCE Solutions

-  Global Sourcing Solution
-  Obsolete Management
-  Cost Control Management
-  Shortage Management
-  Alternative Solution
-  Excess Inventory Management