



# THE DATASHEET OF ZRE200GE



**zilog**<sup>®</sup>

A **Littelfuse** Company

# **ZRE200GE Pyroelectric Sensor Product Specification**

PS040201-0122



**Warning: DO NOT USE IN LIFE SUPPORT**

### **LIFE SUPPORT POLICY**

ZILOG'S PRODUCTS ARE NOT AUTHORIZED FOR USE AS CRITICAL COMPONENTS IN LIFE SUPPORT DEVICES OR SYSTEMS WITHOUT THE EXPRESS PRIOR WRITTEN APPROVAL OF THE PRESIDENT AND GENERAL COUNSEL OF ZILOG CORPORATION.

### **As used herein**

Life support devices or systems are devices which (a) are intended for surgical implant into the body, or (b) support or sustain life and whose failure to perform when properly used in accordance with instructions for use provided in the labeling can be reasonably expected to result in a significant injury to the user. A critical component is any component in a life support device or system whose failure to perform can be reasonably expected to cause the failure of the life support device or system or to affect its safety or effectiveness.

### **Document Disclaimer**

©2022 by Zilog, Inc. All rights reserved. Information in this publication concerning the devices,

applications, or technology described is intended to suggest possible uses and may be superseded. ZILOG, INC. DOES NOT ASSUME LIABILITY FOR OR PROVIDE A REPRESENTATION OF ACCURACY OF THE INFORMATION, DEVICES, OR TECHNOLOGY DESCRIBED IN THIS DOCUMENT. ZILOG ALSO DOES NOT ASSUME LIABILITY FOR INTELLECTUAL PROPERTY INFRINGEMENT RELATED IN ANY MANNER TO USE OF INFORMATION, DEVICES, OR TECHNOLOGY DESCRIBED HEREIN OR OTHERWISE. The information contained within this document has been verified according to the general principles of electrical and mechanical engineering.

Z8, Z80, Z8 Encore!, Z8 Encore! XP and ZMOTION are trademarks or registered trademarks of Zilog, Inc. All other product or service names are the property of their respective owners.

## Revision History

Each instance in this document's revision history reflects a change from its previous edition. For more details, refer to the corresponding page(s) or appropriate links furnished in the table below.

---

<b>Date</b>	<b>Revision Level</b>	<b>Description</b>	<b>Pages</b>
Jan. 2022	01	Original issue.	All

---

## Overview

Zilog's Passive Infrared (PIR) sensors are designed to deliver high performance and excellent EMI immunity for the most demanding motion detection applications.

The ZRE200GE PIR sensor is used in combination with a PIR lens and consists of two sensing elements behind a spectral filter window tuned to 8-13um wavelength to help block out unwanted IR energy sources.

The ZRE200GE comes in a standard TO-5 package and is available with pin lengths of 13.5mm and 3.5mm

### Features

- Dual-element balanced differential (series opposed) PIR sensor
- High PSRR
- Elements are 1mm x 2mm spaced 1mm apart
- Standard metal TO-5 package
- Recommended operating voltage range of 3V to 15V
- Operating temperature range of -20°C to +70°C

### Applications

- General purpose motion detectors
- Lighting
- Video Doorbell
- IP Camera

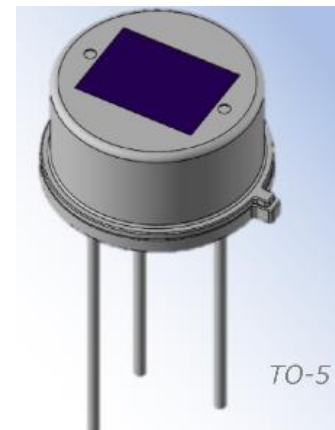

## Ordering Information

Part Number	Description
ZRE200GE	Dual-Element Pyroelectric Sensor – Standard 13.5mm leads (see <a href="#">Mechanical Dimensions</a> )
ZRE200GE35	Dual-Element Pyroelectric Sensor with Trimmed 3.5mm Leads (see <a href="#">Mechanical Dimensions</a> )

## Electrical Characteristics

- |   |  |
|---|--|
| 1) Signal output:                       | Min. 2.5 V <sub>P-P</sub> (Typ. 4.0 V <sub>P-P</sub> )         |
| 2) Noise output:                        | Max. 250 mV <sub>P-P</sub> (Typ. 90 mV <sub>P-P</sub> )        |
| 3) Balance output:                      | Max. 15%   |
|   | $B_o = [SA-SB / SA+SB] \times 100$                             |
|   | Bo: Balance output   |
|   | SA: Absolute signal output on Element A                        |
|   | SB: Absolute signal output on Element B                        |
| 4) Source voltage:                      | 0.3 V to 1.4 V (V <sub>d</sub> : 5V, R <sub>s</sub> : 47K ohm) |
| 5) Operating voltage (V <sub>d</sub> ): | 1 V to 15 V (R <sub>s</sub> : 47K ohm)                         |

### Notes:

Test set-up block diagram see Figure 1 and Figure 2.

Test circuit configuration see Figure 3.

Items 1,2 ,3 and 4 are 100% tested.

## Optical Characteristics

- |                           |  |
|---------------------------|--|
| 1) Typical field of view: | 138 degrees from center of element on axis X<br>125 degrees from center of element on axis Y<br>(See Figure 4) |
| 2) Filter substrate:      | Silicon  |
| 3) Cut on (5%T ABS):      | 5.0 ±1.0 micron  |
| 4) Transmissivity:        | ≥70% average 8 to 13 micron  |

## Environmental Characteristics

- |                           |                          |
|---------------------------|--------------------------|
| 1) Operating temperature: | -20°C to +70°C           |
| 2) Storage temperature:   | -30°C to +80°C           |
| 3) Operating humidity:    | 95% RH or less (at 30°C) |
| 4) Storage humidity:      | 95% RH or less (at 30°C) |

## RoHS Compliance

This product conforms to the RoHS Directive in force at the date of issuance of this Product Specification.

## Test Conditions

The figures below show the configuration under which the PIR sensor electrical characteristics are tested.

**Figure 1 - Test Set-up Configuration**

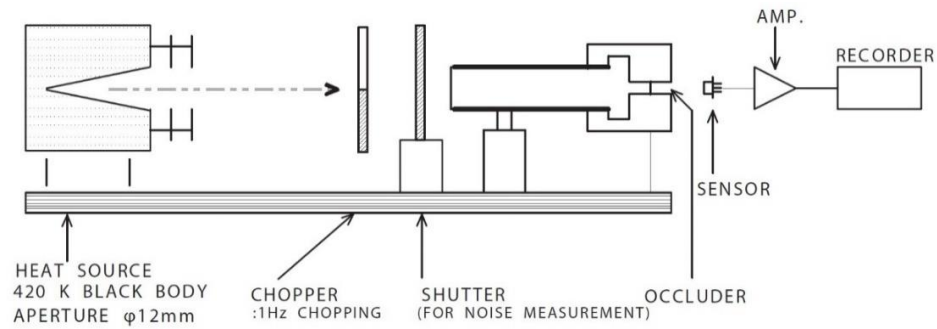

**Figure 2 - Occluder Position**

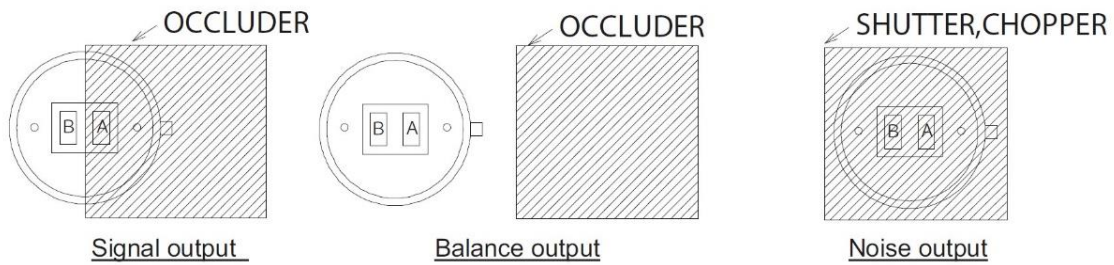

**Figure 3 - Test Circuit Configuration**

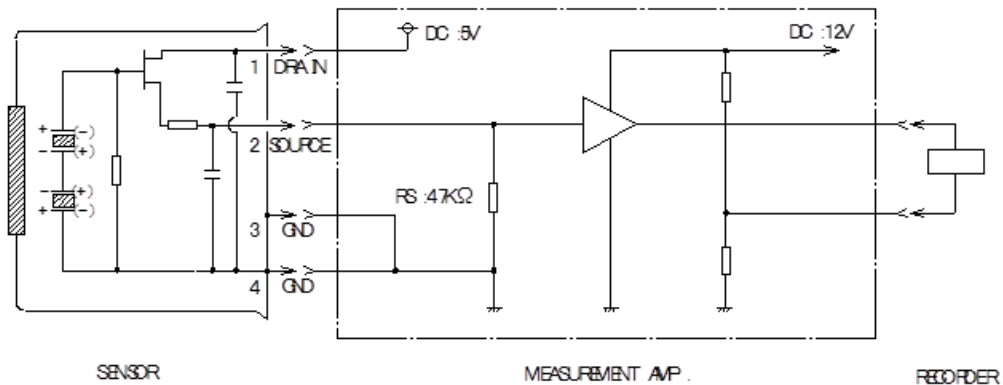

Measurement Amp. Characteristics:

Type: Non-inverting; Gain: 72.5 dB at 1 Hz; Bandwidth: 0.4 to 2.7 Hz / -3 dB

## Field of View

The typical field of view of the ZRE200GE PIR sensor is shown in Figure 4.

**Figure 4 - Field of View**

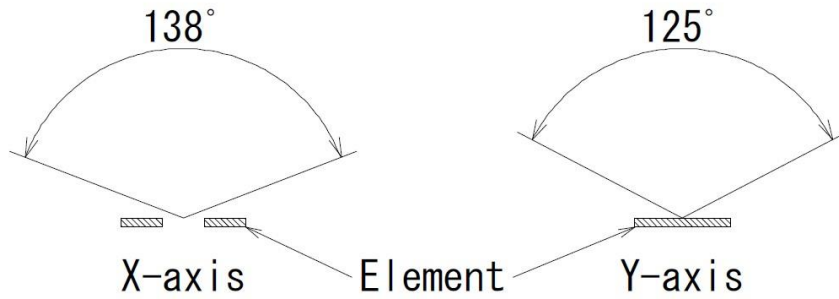

## PIR Sensor Circuit Diagram

The ZRE200GE circuit diagram is shown in Figure 5.

**Figure 5 - Circuit Diagram**

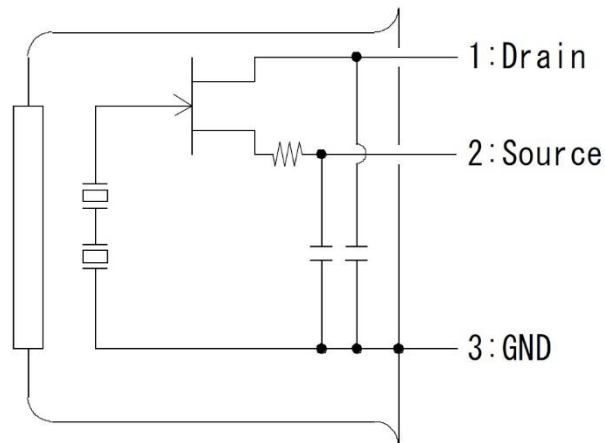

## Mechanical Dimensions

The dimensions of the ZRE200GE and ZRE200GE35 PIR sensor is shown in the following figures. All dimensions are  $\pm 0.2\text{mm}$  unless otherwise stated.

**Figure 6 - Top View**

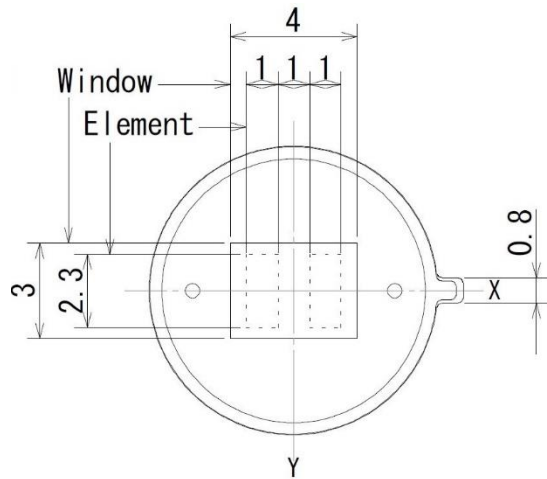

**Figure 7 - Bottom View**

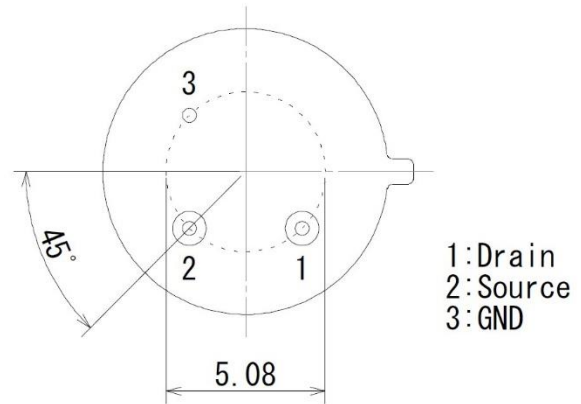

**Figure 9 - ZRE200GE Side View**

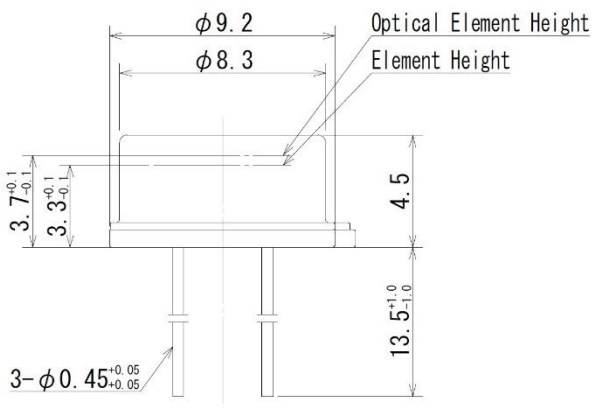

**Figure 8 - ZRE200GE35 Side View**

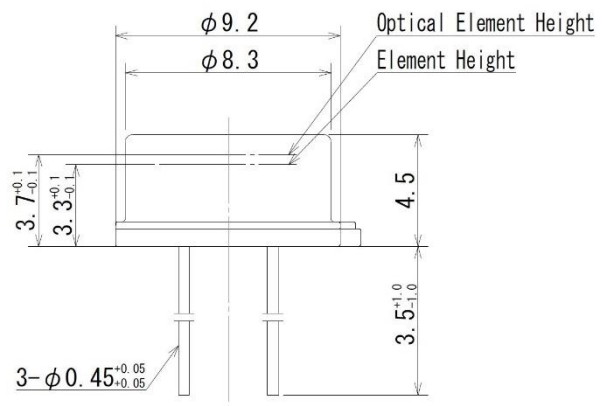

## Device Markings

Lot number information is marked on the top surface of the PIR sensor.

Example: 0 26 B

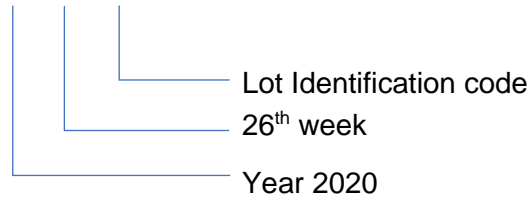

**Figure 10 - Device Markings**

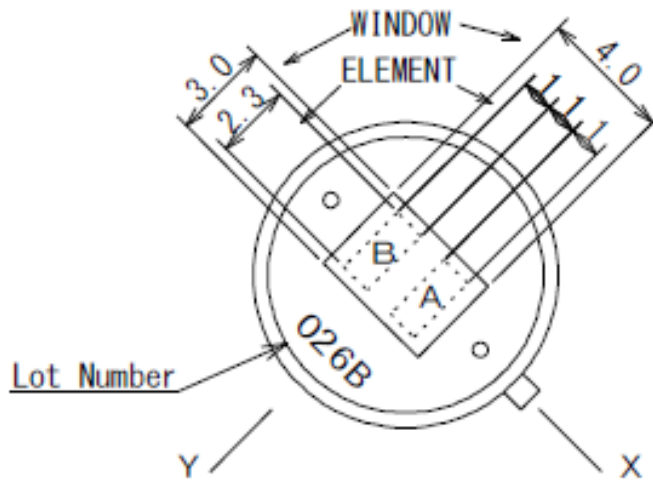

## Packaging

The ZRE200GE PIR sensor is shipped in sheets of 200 pieces, packed in boxes as shown in Figure 11 through Figure 13. The sheets are packed in an inner-box (2 sheets/box = 400 pieces) and 15 inner-boxes are packed in an outer-box for a total of 6,000 pieces per box.

### Sheet and Inner-Box Packaging

- 1) Standard sheet quantity: 200 pieces
- 2) Standard inner-box quantity: 2 Sheets (400 pieces)

Figure 11 – Sheet & Inner-Box Packaging

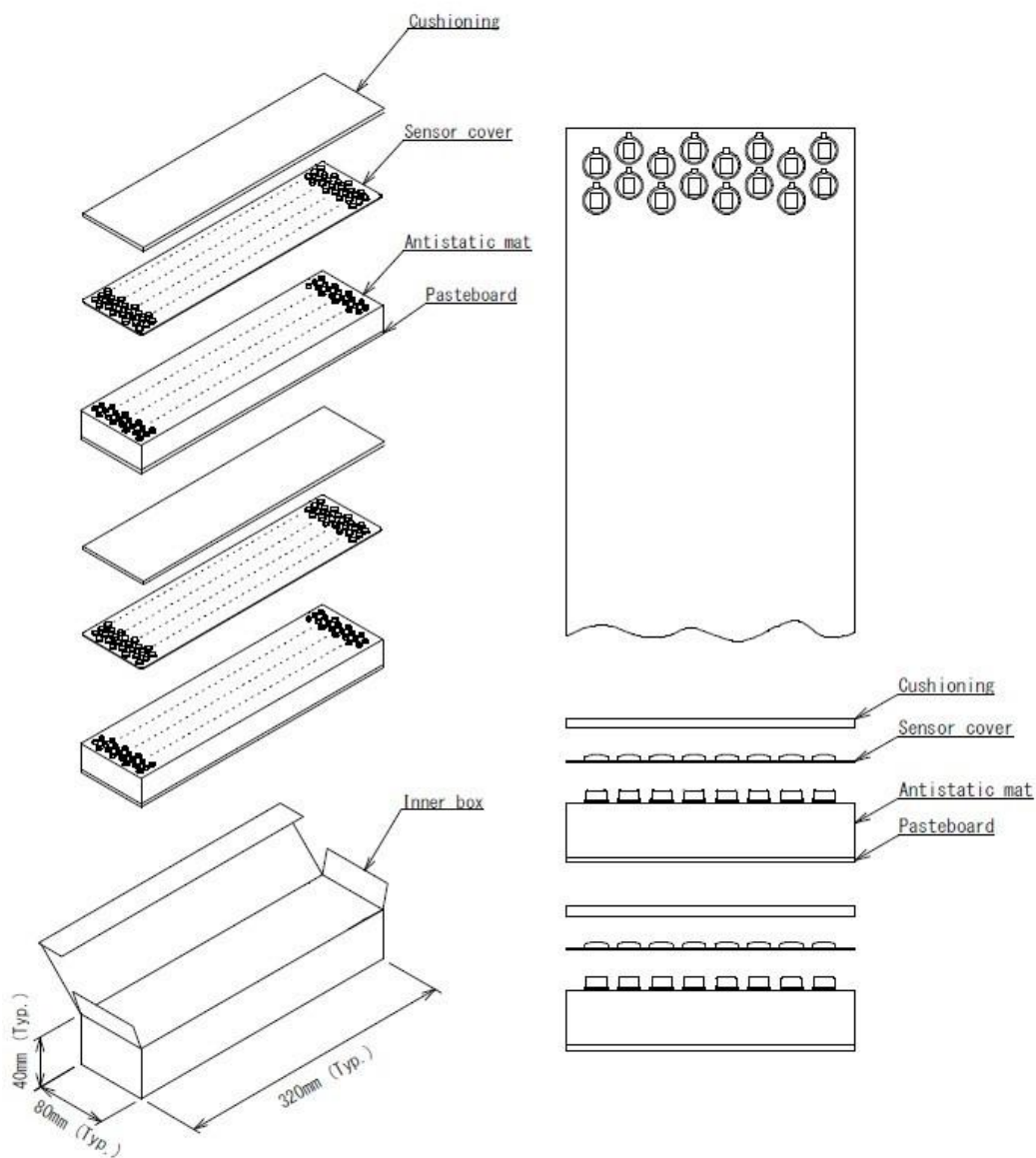

3) Standard Box Quantity: 6,000 pieces (15 Inner-Boxes)

**Figure 12 – Outer-Box Packaging**

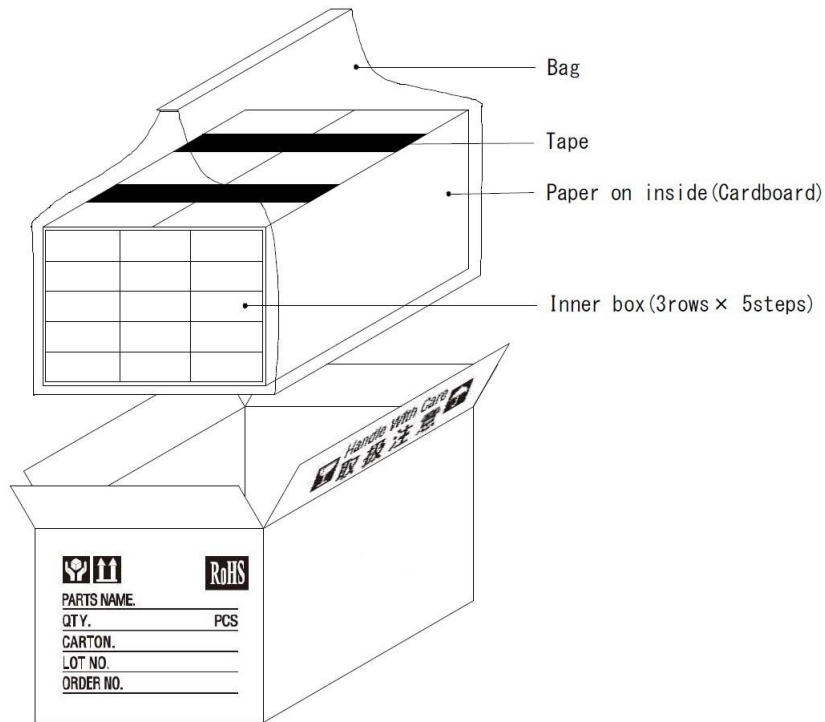

4) The Standard Outer-Box dimensions are shown in Figure 13

**Figure 13 - Standard Outer-Box Dimensions**

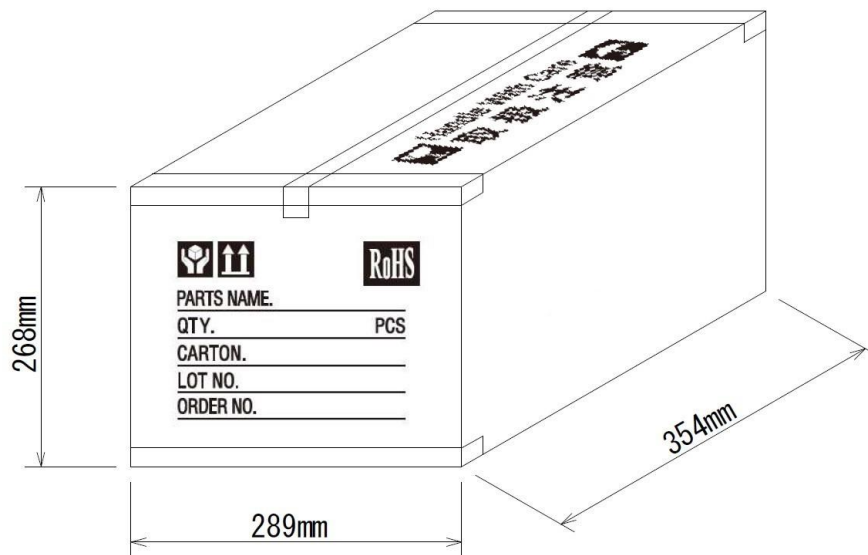

## Usage Restrictions and Precautions

This section presents restrictions and precautions that apply to Zilog pyroelectric sensors.

### Design Restrictions and Precautions

This sensor is designed for indoor purposes in which secondary accidents due to operation failure or malfunctions can be anticipated; therefore, add appropriate fail-safe functionality to your design. If these sensors are intended for outdoor applications, be sure to apply suitable supplementary optical filters and use a waterproof enclosure.

### Usage Restrictions and Precautions

To prevent sensor malfunctions, operational failure, or any deterioration of their characteristics, do not operate these PIR sensors under the following, or similar, conditions:

- Rapid environmental temperature changes
- Strong shocks or vibrations
- In places where there are obstructing materials (glass, fog, etc.) through which infrared rays cannot pass within the detection area
- In fluids, corrosive gases, and sea breezes
- Under continual high-humidity atmospheric conditions
- Exposed to direct sunlight or automobile headlights
- Exposed to directly to forced-air currents from a heater or air conditioner

### Handling and Storage Restrictions and Precautions

To prevent sensor malfunctions, operational failure, appearance damage, or any deterioration of their characteristics, do not expose these sensors to the following, or similar, handling and storage conditions:

- Vibrations over extended periods
- Strong shocks
- Static electricity or strong electromagnetic waves
- High temperature and humidity over extended periods
- Corrosive gases or sea breezes
- Dirty and dusty environments that may contaminate the optical window

## Assembly Restrictions and Precautions

### Soldering:

- Use soldering irons when soldering
- Avoid extended durations of heat on the sensors' pins, because excessive heat may cause deterioration of the sensor (e.g., durations beyond 5 seconds at 350°C)

### Washing:

- Be sure to wash out all flux after soldering. Residual soldering materials may cause malfunctions.
- Use a brush when washing; washing with an ultrasonic cleaner may cause operational failure

## Related Documents

The documents associated with the ZRE200GE PIR sensor are listed below. Each of these documents, and others can be obtained from the [ZMOTION Product Page](#) on the Zilog website: <http://www.zilog.com>.

Document Number	Description
PB0263	PIR Sensor Product Brief
PB0258	ZMOTION MCU Product Brief
PS0264	PIR Lens Product Brief

## Customer Support

To share comments, get your technical questions answered, or report issues you may be experiencing with our products, please visit Zilog's [Technical Support](#) page.

This publication is subject to replacement by a later edition. To determine whether a later edition exists, please visit the Zilog website at <http://www.zilog.com>.

## Looking for pricing, stock, or lifecycle information?

Click below to explore more details on WIN SOURCE:

 [View ZRE200GE on WIN SOURCE](#)

 [Zilog Information](#)

## Optimize Your Supply Chain with WIN SOURCE Solutions

-  Global Sourcing Solution
-  Obsolete Management
-  Cost Control Management
-  Shortage Management
-  Alternative Solution
-  Excess Inventory Management