



**THE DATASHEET OF  
XR3077XIDTR-F**





### General Description

The XR3072X and XR3078X high performance RS-485 / RS-422 devices are designed for improved performance in noisy industrial environments and increased tolerance to system faults.

The analog bus pins can withstand direct shorts up to  $\pm 18V$ , and are protected against ESD events up to  $\pm 15kV$ . The differential high output driver delivers 10% higher SNR than standard RS-485 / RS-422 devices, affording additional noise margin or extended cable lengths.

The receivers include full fail-safe circuitry, guaranteeing a logic-high receiver output when the receiver inputs are open, shorted or undriven. The receiver input impedance is at minimum  $96k\Omega$  (1/8 unit load), allowing up to 256 devices on the bus while preserving the full signal margin.

The drivers are protected by short circuit detection as well as thermal shutdown, and maintain high impedance in shutdown or when powered off. The XR3072X drivers are slew limited for reduced EMI and error-free communication over long or unterminated data cables.

The devices with DE and  $\overline{RE}$  pins include hot swap circuitry to prevent false transitions on the bus during powerup or live insertion, and can enter a 1nA low current shutdown mode for extreme power savings.

The transceivers draw less than  $600\mu A$  from a 3.3V supply, and typically only  $300\mu A$  when idling with the receivers active.

### Features

- 10% higher SNR (Signal-to-Noise Ratio) compared to other RS-485 devices (1.65V vs. 1.5V)
- $\pm 18V$  fault tolerance on analog bus pins
- Robust ESD (ElectroStatic Discharge) protection:
  - $\pm 15kV$  IEC 61000-4-2 Air Gap Discharge
  - $\pm 8kV$  IEC 61000-4-2 Contact Discharge
  - $\pm 15kV$  Human Body Model
  - $\pm 4kV$  Human Body Model on non-bus pins
- 3.0V to 3.6V operation ( $3.3V \pm 10\%$ )
- $300\mu A$  idle current, 1nA shutdown current
- Enhanced receiver fail-safe protection for open, shorted or terminated but idle data lines
- Hot-swap glitch protection on DE and  $\overline{RE}$  pins
- Driver short circuit current limit and thermal shutdown for overload protection
- 1/8<sup>th</sup> unit load allows up to 256 devices on bus
- Industrial operating temperature range ( $-40^{\circ}C$  to  $85^{\circ}C$ )
- Industry standard 8- and 14 -pin NSOIC packages

### Applications

- Motor control
- Security systems
- Building and process automation
- Remote utility meter reading
- Energy monitoring and control
- Long or unterminated transmission lines

Ordering Information - [page 15](#)

### Product Selector Guide

**Table 1: Selector Guide**

Part Number	Duplex	Data Rate	Shutdown	Receiver and Driver Enable	Transceivers on Bus	Footprint
XR3072XIDTR-F	Half	250kbps	Yes	Yes	256	SN75176
XR3078XIDTR-F	Half	20Mbps	Yes	Yes	256	SN75176

## Revision History

Document No.	Release Date	Change Description
1.0.0	Sept 2013	Production release.
1.0.1	Dec 2013	Updated typical driver differential rise / fall time, page 7.
1.0.2	May 2015	Added extended temp range -40°C to 125°C part numbers, updated I <sub>SHDN</sub> for industrial and extended temp range, updated ordering information table and table #7. ECN# 1525-07.
1.0.3	8/30/19	Update to MaxLinear format, update Ordering Information and move to page 15. Move ESD Ratings to below Absolute Maximum Ratings section, Pinout and Block Diagram to Pin Information section, and Product Selector Guide to first page. Remove obsolete products: XR3070X, XR3071X, XR3073X, XR3074X, XR3075X, XR3076X and XR3077X.

## Table of Contents

<b>General Description</b> .....	<b>i</b>
<b>Features</b> .....	<b>i</b>
<b>Applications</b> .....	<b>i</b>
<b>Product Selector Guide</b> .....	<b>i</b>
<b>Specifications</b> .....	<b>1</b>
Absolute Maximum Ratings.....	1
ESD Ratings .....	1
Electrical Characteristics .....	2
<b>Test Circuits and Timing Diagrams</b> .....	<b>5</b>
<b>Pin Information</b> .....	<b>10</b>
Pin Configuration and Block Diagram .....	10
Pin Descriptions .....	10
<b>Product Description</b> .....	<b>11</b>
Enhanced Fail-Safe .....	11
Receiver Input Filtering .....	11
Hot-Swap Capability .....	11
Driver Output Protection .....	11
Line Length.....	11
±15kV ESD Protection.....	12
ESD Test Conditions .....	12
IEC 61000-4-2 .....	12
256 Transceivers on the Bus.....	12
Low Power Shutdown Mode.....	12
<b>Function Tables</b> .....	<b>13</b>
<b>Mechanical Dimensions</b> .....	<b>14</b>
NSOIC8 .....	14
<b>Ordering Information</b> .....	<b>15</b>

## List of Figures

Figure 1: Differential Driver Output Voltage.....	5
Figure 2: Differential Driver Output Voltage Over Common Mode .....	5
Figure 3: Driver Output Short Circuit Current .....	5
Figure 4: Transient Overvoltage Test Circuit.....	6
Figure 5: Driver Propagation Delay Test Circuit and Timing Diagram.....	6
Figure 6: Driver Enable and Disable Timing Test Circuits and Timing Diagrams.....	7
Figure 7: Receiver Propagation Delay Test Circuit and Timing Diagram .....	8
Figure 8: Receiver Enable and Disable Test Circuits and Timing Diagrams.....	9
Figure 9: Pin Configuration and Half-Duplex Block Diagram.....	10
Figure 10: Mechanical Dimension, NSOIC8 .....	14

## List of Tables

Table 1: Selector Guide .....	i
Table 1: Absolute Maximum Ratings .....	1
Table 2: ESD Ratings .....	1
Table 3: Electrical Characteristics .....	2
Table 4: Pin Descriptions.....	10
Table 5: Half Duplex Transmitting .....	13
Table 6: Half Duplex Receiving .....	13
Table 7: Ordering Information.....	15

## Specifications

### Absolute Maximum Ratings

**Important:** These are stress ratings only and functional operation of the device at these ratings or any other above those indicated in the operation sections of the specifications below is not implied. Exposure to absolute maximum rating conditions for extended periods of time may affect reliability and cause permanent damage to the device.

**Table 1: Absolute Maximum Ratings**

Parameter	Minimum	Maximum	Units
$V_{CC}$	-0.3	7.0	V
Input voltage at control and driver input ( $\overline{RE}$ , DE and DI)	-0.3	7.0	V
Receiver output voltage (RO)	-0.3	$V_{CC} + 0.3$	V
Driver output voltage (A, B, Y & Z)	-18	18	V
Receiver input voltage (A, B)	-18	18	V
Transient voltage pulse, through 100 $\Omega$ , <a href="#">Figure 5</a>	-70	70	V
Driver output current	-250	250	mA
Storage temperature range	-65	150	$^{\circ}\text{C}$
Lead temperature (soldering, 10s)		300	$^{\circ}\text{C}$
Package Power Dissipation			
8-pin SO, $\Theta_{JA} = 128.4^{\circ}\text{C/W}$	Maximum junction temperature = 150 $^{\circ}\text{C}$		
14-pin SO, $\Theta_{JA} = 86^{\circ}\text{C/W}$			

### ESD Ratings

**Table 2: ESD Ratings**

Parameter	Limit	Units
HBM - Human Body Model (pins A, B, Y & Z)	$\pm 15$	kV
HBM - Human Body Model (all other pins)	$\pm 4$	kV
IEC 1000-4-2 Airgap Discharge (pins A, B, Y & Z)	$\pm 15$	kV
IEC 1000-4-2 Contact Discharge (pins A, B, Y & Z)	$\pm 8$	kV

**Caution:**

ESD (Electrostatic Discharge) sensitive device. Permanent damage may occur on unconnected devices subject to high energy electrostatic fields. Unused devices must be stored in conductive foam or shunts. Personnel should be properly grounded prior to handling this device. The protective foam should be discharged to the destination socket before devices are removed.

## Electrical Characteristics

Unless otherwise noted,  $V_{CC} = 3.3V \pm 10\%$ ,  $T_A = T_{MIN}$  to  $T_{MAX}$ . Typical values are at  $V_{CC} = 3.3V$ ,  $T_A = 25^\circ C$ .

**Table 3: Electrical Characteristics**

Parameter	Symbol	Test Condition	Minimum	Typical	Maximum	Units
Driver DC Characteristics						
Supply voltage range	$V_{CC}$		3.0		3.6	V
Differential Driver Output	$V_{OD}$	No load	3		$V_{CC}$	V
		$R_L = 100$ (RS-422), <a href="#">Figure 2</a>	2		$V_{CC}$	
		$R_L = 54$ (RS-485), <a href="#">Figure 2</a>	1.65		$V_{CC}$	
		$-7V \leq V_{CM} \leq 12V$ , <a href="#">Figure 3</a>	1.5		$V_{CC}$	
Change in magnitude of differential output voltage	$DV_{OD}$				$\pm 0.2$	V
Driver common mode output voltage (steady state)	$V_{CM}$	$R_L = 54\Omega$ (RS-485) or $R_L = 100\Omega$ (RS-422), <a href="#">Figure 2</a> <sup>(1)</sup>		$V_{CC}/2$	3	V
Change in magnitude of common-mode output voltage	$DV_{CM}$				$\pm 0.2$	V
Logic input thresholds (DI, DE, $\overline{RE}$ )	$V_{IH}$	Logic input high	2			V
	$V_{IL}$	Logic input low			0.8	V
Input hysteresis (DI, DE, $\overline{RE}$ )	$V_{HYS}$			100		mV
Logic input current (DI, DE, $\overline{RE}$ )	$I_{IN}$	$0V \leq V_{IN} \leq V_{CC}$ , after first transition <sup>(2)</sup>			$\pm 1$	$\mu A$
Logic input current (DE and $\overline{RE}$ )		Until first transition <sup>(2)</sup>		100	$\pm 200$	$\mu A$
Input Current (A and B)	$I_{A,B}$	$V_{OUT} = 12V$ , $DE = 0V$ , $V_{CC} = 0V$ or $5.5V$			125	$\mu A$
		$V_{OUT} = -7V$ , $DE = 0V$ , $V_{CC} = 0V$ or $5.5V$	-100			
Driver short-circuit output current	$I_{OSD}$	$-7V \leq V_{OUT} \leq 12V$ , <a href="#">Figure 4</a>			$\pm 250$	mA
Driver Thermal Characteristics						
Thermal shutdown threshold	$T_{TS}$	Junction temperature <sup>(4)</sup>		175		$^\circ C$
Thermal shutdown hysteresis <sup>(4)</sup>	$T_{TSH}$			15		$^\circ C$
Receiver DC Characteristics						
Receiver differential threshold voltage ( $V_A - V_B$ )	$V_{TH}$	$-7V \leq V_{CM} \leq 12V$	-200	-125	-50	mV
Receiver input hysteresis	$DV_{OH}$	$V_{CM} = 0V$		25		mV
Receiver output high voltage (RO)	$V_{OH}$	$I_O = -1mA$	$V_{CC} - 0.6$			V
Receiver output low voltage (RO)	$V_{OL}$	$I_O = 1mA$			0.4	V
High-Z receiver output current	$I_{OZR}$	$0 \leq V_{OUT} \leq V_{CC}$			$\pm 1$	$\mu A$
Receiver input resistance	$R_{IN}$	$-7V \leq V_{CM} \leq 12V$	96			k $\Omega$
Receiver output short-circuit current	$I_{OSC}$	$0V \leq V_{RO} \leq V_{CC}$			$\pm 80$	mA

**Table 3: Electrical Characteristics (Continued)**

Parameter	Symbol	Test Condition	Minimum	Typical	Maximum	Units
Supply Current						
Supply current	$I_{CC}$	No load, $\overline{RE} = 0V$ , $DE = V_{CC}$ , $DI = 0V$		425	600	$\mu A$
		No load, $\overline{RE} = V_{CC}$ , $DE = V_{CC}$ , $DI = 0V$		330	600	
		No load, $\overline{RE} = 0V$ , $DE = 0V$ Receiver A and B inputs open		300	500	
Supply current in shutdown mode	$I_{SHDN}$	$\overline{RE} = V_{CC}$ , $DE = 0V$		0.001	1	$\mu A$
Driver AC Characteristics - XR3072X (250kbps)						
Driver propagation delay (low to high)	$t_{DPLH}$	$C_L = 50pF$ , $R_L = 54\Omega$ , <b>Figure 6</b>	250		1500	ns
Driver propagation delay (high to low)	$t_{DPHL}$		250		1500	ns
Differential driver output skew	$ t_{DPLH} - t_{DPHL} $			20	200	ns
Driver differential output rise or fall time	$t_{DR}$ , $t_{DF}$		350		1600	ns
Maximum data rate		$1/t_{UI}$ , duty cycle 40% to 60%	250			kbps
Driver enable to output high	$t_{DZH}$	$C_L = 50pF$ , $R_L = 500\Omega$ , <b>Figure 7</b>		200	2500	ns
Driver enable to output low	$t_{DZL}$			200	2500	ns
Driver disable from output high	$t_{DZH}$			6	100	ns
Driver disable from output low	$t_{DLZ}$			6	100	ns
Driver enable from shutdown to output high	$t_{DZH(SHDN)}$	$C_L = 50pF$ , $R_L = 500\Omega$ , <b>Figure 7</b>			5500	ns
Driver enable from shutdown to output low	$t_{DZL(SHDN)}$				5500	ns
Time to shutdown <sup>(3, 4)</sup>	$t_{SHDN}$		50	200	600	ns
Receiver AC Characteristics - XR3072X (250kbps)						
Receiver propagation delay (low to high)	$t_{RPLH}$	$C_L = 15pF$ , $V_{ID} = \pm 2V$ , $V_{ID}$ rise and fall times < 15ns <b>Figure 8</b>			200	ns
Receiver propagation delay (high to low)	$t_{RPHL}$				200	ns
Propagation delay skew	$t_{RPLH} - t_{RPHL}$				30	ns
Maximum data rate		$1/t_{UI}$ , duty cycle 40% to 60%	250			kbps
Receiver enable to output high	$t_{RZH}$	$C_L = 15pF$ , $R_L = 1k\Omega$ , <b>Figure 9</b>			50	ns
Receiver enable to output low	$t_{RZL}$				50	ns
Receiver disable from output high	$t_{RHZ}$				50	ns
Receiver disable from output low	$t_{RLZ}$				50	ns
Receiver enable from shutdown to output high	$t_{RZH(SHDN)}$	$C_L = 15pF$ , $R_L = 1k\Omega$ , <b>Figure 9</b>			3500	ns
Receiver enable from shutdown to output low	$t_{RZL(SHDN)}$				3500	ns
Time to shutdown <sup>(3, 4)</sup>	$t_{SHDN}$		50	200	600	ns

**Table 3: Electrical Characteristics (Continued)**

Parameter	Symbol	Test Condition	Minimum	Typical	Maximum	Units
Driver AC Characteristics - XR3078X (20Mbps)						
Driver propagation delay (low to high)	$t_{DPLH}$	$C_L = 50\text{pF}$ , $R_L = 54\Omega$ , <b>Figure 6</b>			25	ns
Driver propagation delay (high to low)	$t_{DPHL}$				25	ns
Differential driver output skew	$ t_{DPLH} - t_{DPHL} $				5	ns
Driver differential output rise or fall time	$t_{DR}$ , $t_{DF}$			12		ns
Maximum data rate		$1/t_{UI}$ , duty cycle 40% to 60%	20			Mbps
Driver enable to output high	$t_{DZH}$	$C_L = 50\text{pF}$ , $R_L = 500\Omega$ , <b>Figure 7</b>			45	ns
Driver enable to output low	$t_{DZL}$				45	ns
Driver disable from output high	$t_{DHZ}$				40	ns
Driver disable from output low	$t_{DLZ}$				40	ns
Driver enable from shutdown to output high	$t_{DZH(SHDN)}$	$C_L = 50\text{pF}$ , $R_L = 500\Omega$ , <b>Figure 7</b>			250	ns
Driver enable from shutdown to output low	$t_{DZL(SHDN)}$				250	ns
Time to shutdown <sup>(3, 4)</sup>	$t_{SHDN}$		50	200	600	ns
Receiver AC Characteristics - XR3078X (20Mbps)						
Receiver propagation delay (low to high)	$t_{RPLH}$	$C_L = 15\text{pF}$ , $V_{ID} = \pm 2\text{V}$ , $V_{ID}$ rise and fall times < 15ns <b>Figure 8</b>			50	ns
Receiver propagation delay (high to low)	$t_{RPHL}$				50	ns
Propagation delay skew	$ t_{RPLH} - t_{RPHL} $				5	ns
Maximum data rate		$1/t_{UI}$ , duty cycle 40% to 60%	20			Mbps
Receiver enable to output high	$t_{RZH}$	$C_L = 15\text{pF}$ , $R_L = 1\text{k}\Omega$ , <b>Figure 9</b>			30	ns
Receiver enable to output low	$t_{RZL}$				30	ns
Receiver disable from output high	$t_{RHZ}$				30	ns
Receiver disable from output low	$t_{RLZ}$				30	ns
Receiver enable from shutdown to output high	$t_{RZH(SHDN)}$	$C_L = 15\text{pF}$ , $R_L = 1\text{k}\Omega$ , <b>Figure 9</b>			1800	ns
Receiver enable from shutdown to output low	$t_{RZL(SHDN)}$				1800	ns
Time to shutdown <sup>(3, 4)</sup>	$t_{SHDN}$		50	200	600	ns

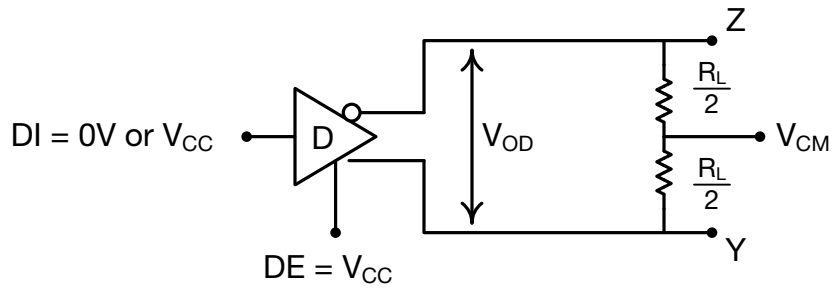
1. Change in magnitude of differential output voltage and change in magnitude of common mode output voltage are the changes in output voltage when DI input changes state.

2. The hot swap feature disables the DE and  $\overline{RE}$  inputs for the first 10 $\mu\text{s}$  after power is applied. Following this time period these inputs are weakly pulled to their disabled state (low for DE, high for  $\overline{RE}$ ) until the first transition, after which they become high impedance inputs.

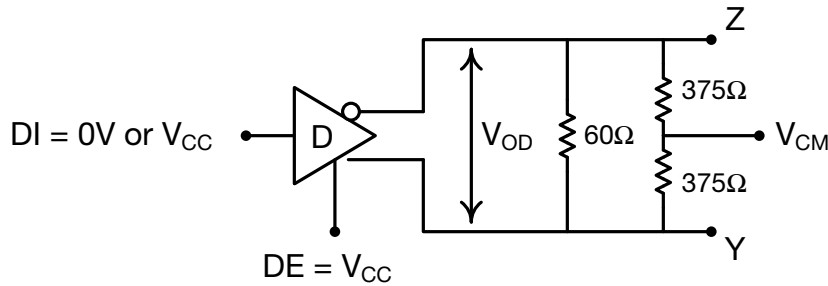
3. The transceivers are put into shutdown by bringing  $\overline{RE}$  high and DE low simultaneously for at least 600ns. If the control inputs are in this state for less than 50ns, the device is guaranteed to not enter shutdown. If the enable inputs are held in this state for at least 600ns, the device is assured to be in shutdown. Note that the receiver and driver enable times increase significantly when coming out of shutdown.

4. This spec is guaranteed by design and bench characterization.

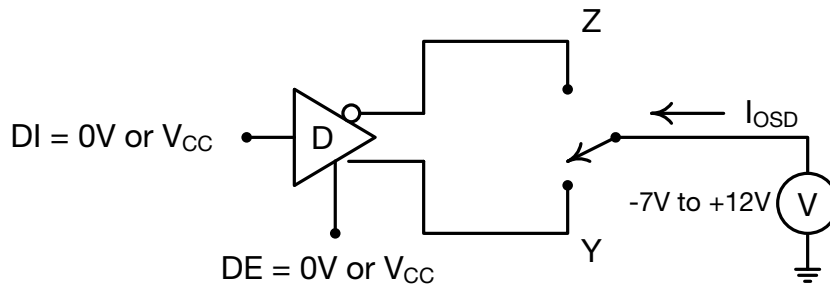
## Test Circuits and Timing Diagrams



**Figure 2: Differential Driver Output Voltage**

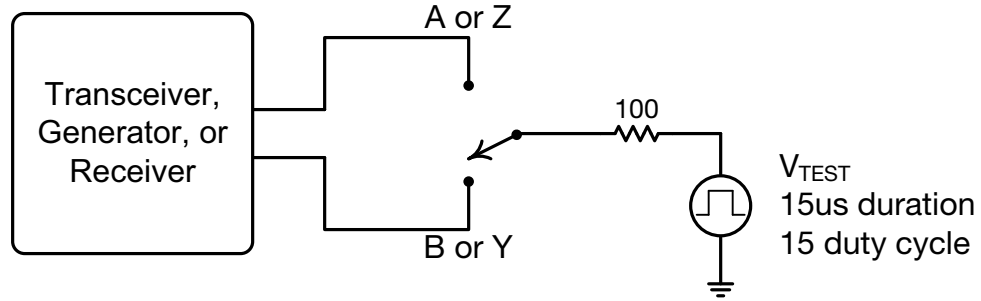


**Figure 3: Differential Driver Output Voltage Over Common Mode**

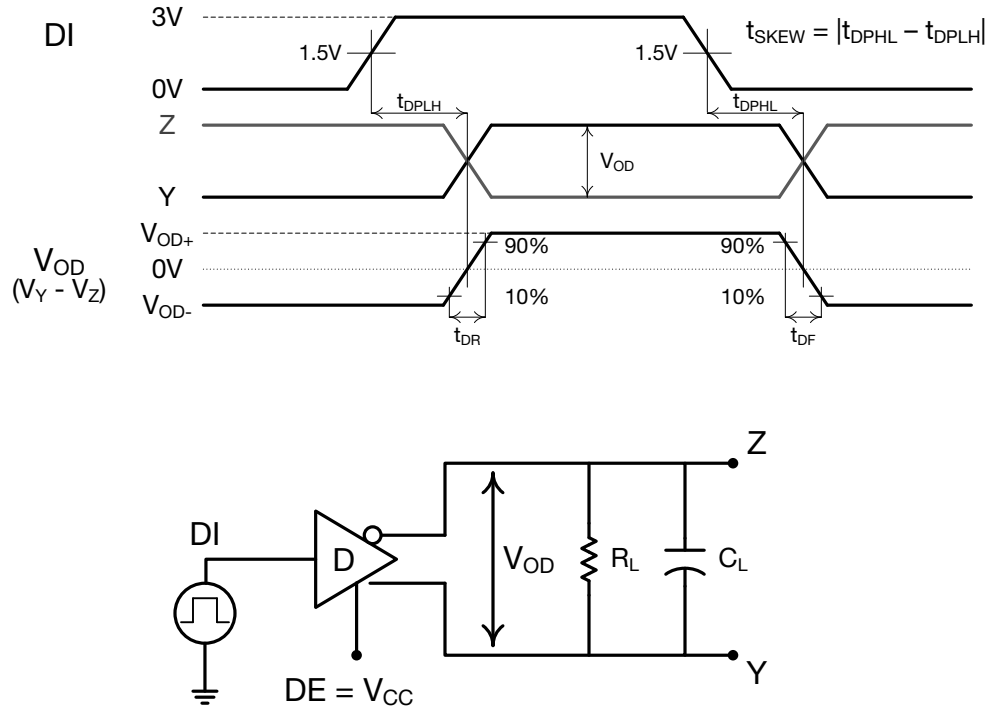


**Figure 4: Driver Output Short Circuit Current**

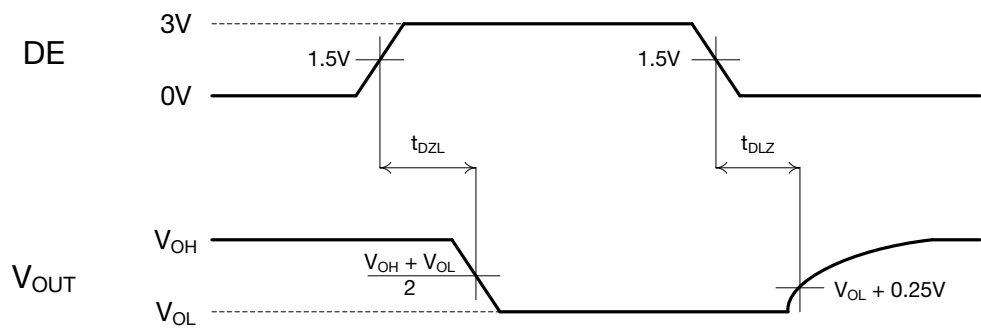
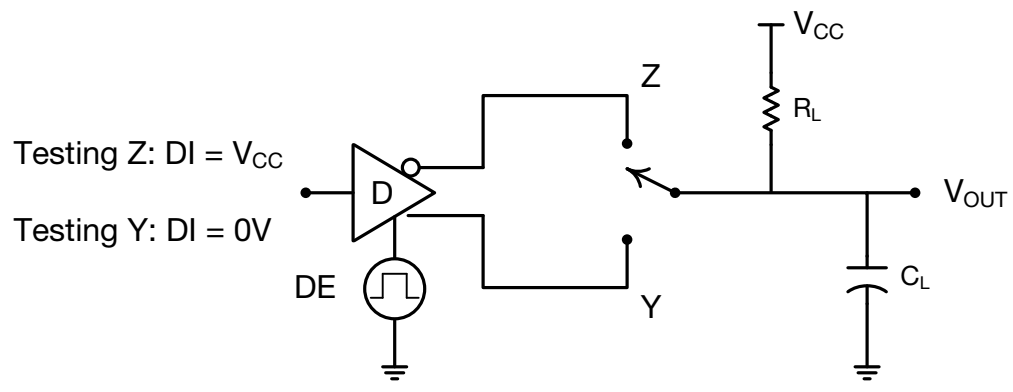
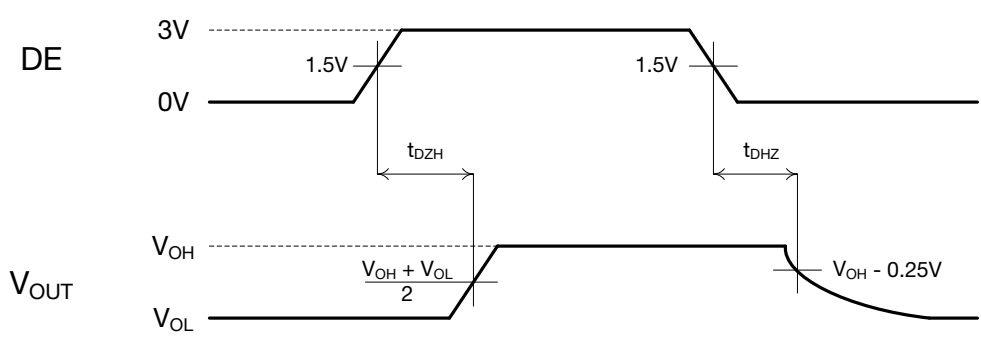
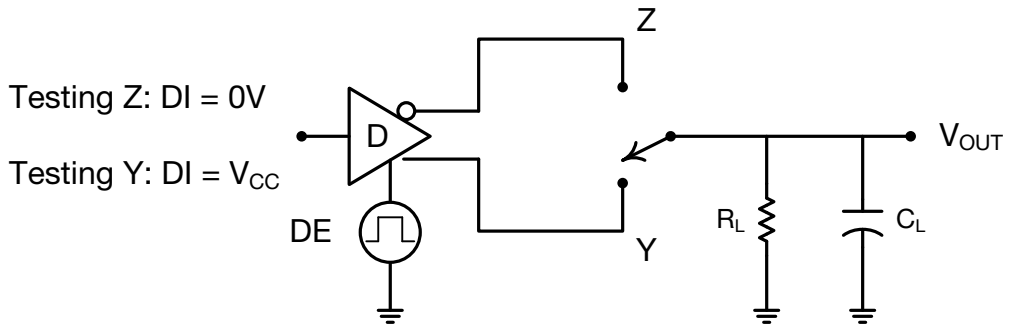
Device powered on or powered off



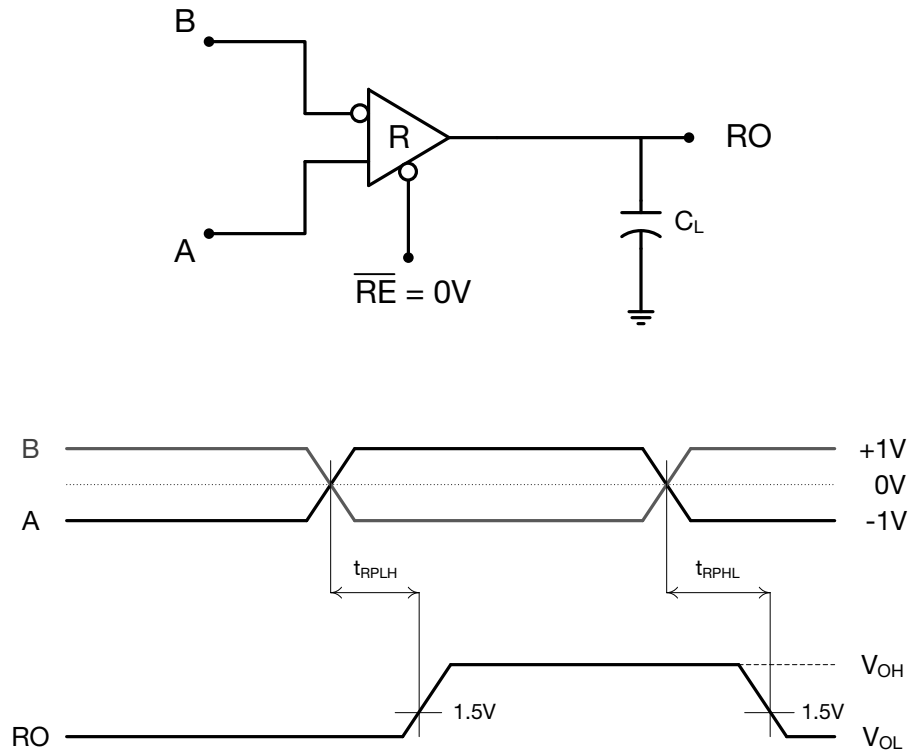
**Figure 5: Transient Overvoltage Test Circuit**



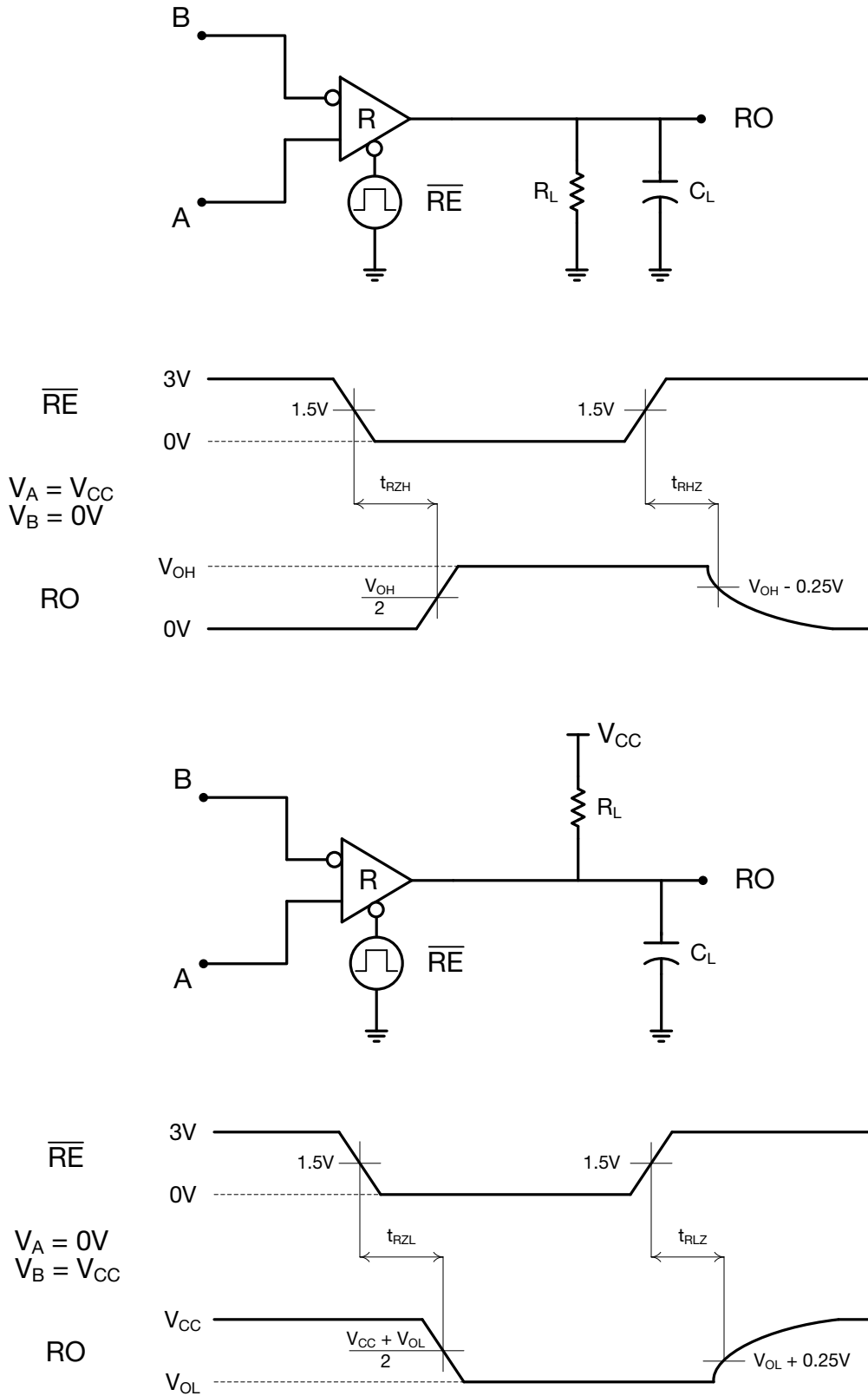
**Figure 6: Driver Propagation Delay Test Circuit and Timing Diagram**



**Figure 7: Driver Enable and Disable Timing Test Circuits and Timing Diagrams**



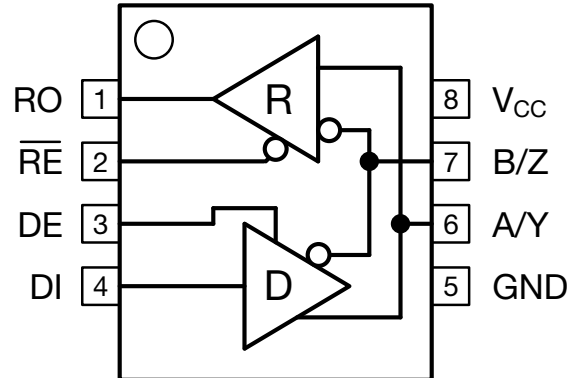
**Figure 8:** Receiver Propagation Delay Test Circuit and Timing Diagram



**Figure 9: Receiver Enable and Disable Test Circuits and Timing Diagrams**

## Pin Information

### Pin Configuration and Block Diagram



**Figure 10: Pin Configuration and Half-Duplex Block Diagram**

### Pin Descriptions

**Table 4: Pin Descriptions**

Pin Number	Pin Name	Type	Pin Function
1	RO	Out	Receiver output. When $\overline{RE}$ is low and if $(A-B) \leq -50\text{mV}$ , RO is High. If $(A-B) \geq -200\text{mV}$ , RO is low.
2	$\overline{RE}$	In	Receiver output enable (Hot swap). When $\overline{RE}$ is low, RO is enabled. When $\overline{RE}$ is high, RO is high impedance. $\overline{RE}$ should be high and DE should be low to enter shutdown mode.
3	DE	In	Driver output enable (Hot swap). When DE is high, outputs are enabled. When DE is low, outputs are high impedance. DE should be low and $\overline{RE}$ should be high to enter shutdown mode.
4	DI	In	Driver input. With DE high, a low level on DI forces non-inverting output low and inverting output high. Similarly, a high level on DI forces non-inverting output high and inverting output low.
5	GND	Pwr	Ground.
6	A	I / O	Non-inverting receiver input and non-inverting driver output.
7	B	I / O	Inverting receiver input and inverting driver output.
8	V <sub>CC</sub>	Pwr	3.3V positive supply input. Bypass to GND with a 0.1 $\mu\text{F}$ capacitor.

## Product Description

The XR3072X and XR3078X RS-485 / RS-422 devices are part of MaxLinear's X Series high performance serial interface product line. The analog bus pins can survive direct shorts up to  $\pm 18V$ , and are protected against ESD events up to  $\pm 15kV$ . The high output differential driver delivers 10% higher SNR than other RS-485 / 422 devices, affording additional noise margin or extended cable lengths.

## Enhanced Fail-Safe

Ordinary RS-485 differential receivers will be in an indeterminate state whenever the data bus is not being actively driven. The enhanced failsafe feature of the XR3072X and XR3078X guarantees a logic-high receiver output when the receiver inputs are open, shorted, or when they are connected to a terminated transmission line with all drivers disabled. In a terminated bus with all transmitters disabled, the receivers' differential input voltage is pulled to 0V by the termination. The XR3072X and XR3078X interpret 0V differential as a logic high with a minimum 50mV noise margin while maintaining compliance with the EIA / TIA-485 standard of  $\pm 200mV$ . Although the XR3072X and XR3078X do not need failsafe biasing resistors, they can operate without issue if biasing is used.

## Receiver Input Filtering

The XR3072X receiver incorporates internal filtering in addition to input hysteresis. This filtering enhances noise immunity by ignoring signals that do not meet a minimum pulse width of 30ns. Receiver propagation delay increases slightly due to this filtering. The high speed XR3078X does not have this input filtering.

## Hot-Swap Capability

When  $V_{CC}$  is first applied, the XR3072X and XR3078X hold the driver enable and receiver enable inactive for approximately 10 microseconds. During power ramp-up, other system ICs may drive unpredictable values, or tri-stated lines may be influenced by stray capacitance. The hot-swap feature prevents these devices from driving any output signal until power has stabilized. After the initial 10 $\mu s$ , the driver and receiver enable pins are weakly pulled to their disabled states (low for DE, high for  $\overline{RE}$ ) until the first transition. After the first transition, the DE and  $\overline{RE}$  pins operate as high impedance inputs.

If circuit boards are inserted into an energized backplane (commonly called "live insertion" or "hot-swap"), power may suddenly be applied to all circuits. Without the hot-swap capability, this situation could improperly enable the transceiver's driver or receiver, driving invalid data onto shared buses and possibly causing driver contention or device damage.

## Driver Output Protection

Two mechanisms prevent excessive output current and power dissipation caused by faults or by bus contention. First, a driver current limit on the output stage provides immediate protection against short circuits over the whole common-mode voltage range. Second, a thermal shutdown circuit forces the driver outputs into a high-impedance state if junction temperature becomes excessive.

## Line Length

The RS-485 / RS-422 standard covers line lengths up to 4000ft. Maximum achievable line length is a function of signal attenuation and noise. Termination prevents signal reflections by eliminating the impedance mismatches on a transmission line. Line termination is generally used if rise and fall times are shorter than the round-trip signal propagation time. Higher output drivers may allow longer cables to be used.

## ±15kV ESD Protection

ESD-protection structures are incorporated on all pins to protect against electrostatic discharges encountered during handling and assembly. The driver output and receiver inputs of the XR3072X and XR3078X have extra protection against static electricity. MaxLinear's uses state of the art structures to protect these pins against ESD of ±15kV without damage. The ESD structures withstand high ESD in all states: normal operation, shutdown and powered down. After an ESD event, the XR3072X and XR3078X keep operating without latch-up or damage.

ESD protection can be tested in various ways. The transmitter outputs and receiver inputs of the XR3072X and XR3078X are characterized for protection to the following limits:

- ±15kV using the Human Body Model
- ±8kV using the Contact Discharge Model
- ±15kV Air-gap Discharge Model

## ESD Test Conditions

ESD performance depends on a variety of conditions. Contact MaxLinear for a reliability report that documents test setup, methodology and results.

## IEC 61000-4-2

The IEC 61000-4-2 standard covers ESD testing and performance of finished equipment. However, it does not specifically refer to integrated circuits. The XR3072X and XR3078X help you design equipment to meet IEC 61000-4-2, without sacrificing board space and cost for external ESD-protection components.

The major difference between tests done using the Human Body Model and IEC 61000-4-2 is higher peak current in IEC 61000-4-2. Series resistance is lower in the IEC 61000-4-2 model. Hence, the ESD withstand voltage measured to IEC 61000-4-2 is generally lower than that of the Human Body Model.

The air-gap test involves approaching the device with a charged probe. The contact discharge method connects the probe to the device before the probe is energized.

## 256 Transceivers on the Bus

The standard RS-485 receiver input impedance is 12kΩ (1 unit load). A standard driver can drive up to 32 unit loads. The XR3072X and XR3078X have a 1/8<sup>th</sup> unit load receiver input impedance (96kΩ), allowing up to 256 transceivers to be connected in parallel on a communication line. Any combination of these devices and other RS-485 transceivers up to a total of 32 unit loads may be connected to the line.

## Low Power Shutdown Mode

Low-power shutdown mode is initiated by bringing both  $\overline{RE}$  high and DE low simultaneously. While in shutdown, devices draw less than 1μA of supply current. DE and  $\overline{RE}$  may be tied together and driven by a single control signal. Devices are guaranteed not to enter shutdown if  $\overline{RE}$  is high and DE is low for less than 50ns. If the inputs are in this state for at least 600ns, the parts will enter shutdown.

Enable times  $t_{ZH}$  and  $t_{ZL}$  apply when the part is not in a low-power shutdown state. Enable times  $t_{ZH(SHDN)}$  and  $t_{ZL(SHDN)}$  apply when the parts are shutdown. The drivers and receivers take longer to become enabled from low-power shutdown mode  $t_{ZH(SHDN)}$  and  $t_{ZL(SHDN)}$  than from driver /receiver-disable mode ( $t_{ZH}$ ,  $t_{ZL}$ ).

## Function Tables

**Table 5: Half Duplex Transmitting**

Transmitting				
Inputs			Outputs	
$\overline{RE}$	DE	DI	Y	Z
X	1	1	1	0
X	1	0	0	1
0	0	X	High-Z	
1	0	X	Shutdown	

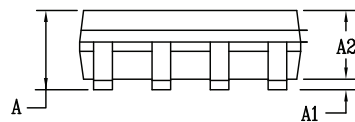
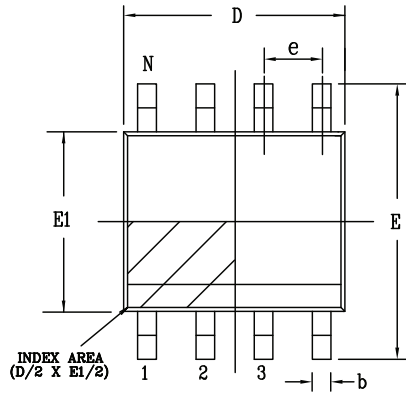
**Table 6: Half Duplex Receiving**

Receiving			
Inputs			Output
$\overline{RE}$	DE	$V_A - V_B$	RO
0	X	$\geq -50\text{mV}$	1
0	X	$\leq -200\text{mV}$	0
0	X	Open / shorted	1
1	1	X	High-Z
1	0	X	Shutdown

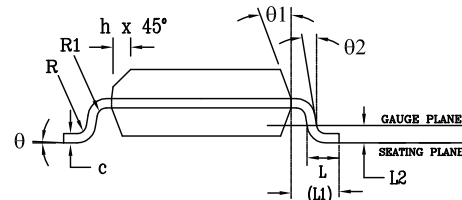
1. Receiver inputs  $-200\text{mV} \leq V_A - V_B \leq -50\text{mV}$  are considered indeterminate.

# Mechanical Dimensions

## NSOIC8



Side View



Front View

PACKAGE OUTLINE NSOIC .150" BODY JEDEC MS-012 VARIATION AA						
SYMBOLS	COMMON DIMENSIONS IN MM (Control Unit)			COMMON DIMENSIONS IN INCH (Reference Unit)		
	MIN	NOM	MAX	MIN	NOM	MAX
A	1.35	—	1.75	0.053	—	0.069
A1	0.10	—	0.25	0.004	—	0.010
A2	1.25	—	1.65	0.049	—	0.065
b	0.31	—	0.51	0.012	—	0.020
c	0.17	—	0.25	0.007	—	0.010
E	6.00 BSC			0.236 BSC		
E1	3.90 BSC			0.154 BSC		
e	1.27 BSC			0.050 BSC		
h	0.25	—	0.50	0.010	—	0.020
L	0.40	—	1.27	0.016	—	0.050
L1	1.04 REF			0.041 REF		
L2	0.25 BSC			0.010 BSC		
R	0.07	—	—	0.003	—	—
R1	0.07	—	—	0.003	—	—
q	0°	—	8°	0°	—	8°
q1	5°	—	15°	5°	—	15°
q2	0°	—	—	0°	—	—
D	4.90 BSC			0.193 BSC		
N	8			8		

Drawing No: POD-0000108  
Revision: A

Figure 11: Mechanical Dimension, NSOIC8

## Ordering Information

**Table 7: Ordering Information**

Ordering Part Number	Operating Temperature Range	Package	Packaging Method	Lead-Free <sup>(2)</sup>	Duplex / Data Rate
XR3072X					
XR3072XID-F	-40°C to 85°C	NSOIC8	Tube	Yes	Half / 250kbps
XR3072XIDTR-F	-40°C to 85°C	NSOIC8	Reel	Yes	Half / 250kbps
XR3078X					
XR3078XID-F	-40°C to 85°C	NSOIC8	Tube	Yes	Half / 20Mbps
XR3078XIDTR-F	-40°C to 85°C	NSOIC8	Reel	Yes	Half / 20Mbps

1. Refer to [www.maxlinear.com/XR3072X](http://www.maxlinear.com/XR3072X) and [www.maxlinear.com/XR3078X](http://www.maxlinear.com/XR3078X) for most up-to-date Ordering Information.

2. Visit [www.maxlinear.com](http://www.maxlinear.com) for additional information on Environmental Rating.



MaxLinear, Inc.  
5966 La Place Court, Suite 100  
Carlsbad, CA 92008  
760.692.0711 p.  
760.444.8598 f.  
[www.maxlinear.com](http://www.maxlinear.com)

The content of this document is furnished for informational use only, is subject to change without notice, and should not be construed as a commitment by MaxLinear, Inc. MaxLinear, Inc. assumes no responsibility or liability for any errors or inaccuracies that may appear in the informational content contained in this guide. Complying with all applicable copyright laws is the responsibility of the user. Without limiting the rights under copyright, no part of this document may be reproduced into, stored in, or introduced into a retrieval system, or transmitted in any form or by any means (electronic, mechanical, photocopying, recording, or otherwise), or for any purpose, without the express written permission of MaxLinear, Inc.


MaxLinear, Inc. does not recommend the use of any of its products in life support applications where the failure or malfunction of the product can reasonably be expected to cause failure of the life support system or to significantly affect its safety or effectiveness. Products are not authorized for use in such applications unless MaxLinear, Inc. receives, in writing, assurances to its satisfaction that: (a) the risk of injury or damage has been minimized; (b) the user assumes all such risks; (c) potential liability of MaxLinear, Inc. is adequately protected under the circumstances.

MaxLinear, Inc. may have patents, patent applications, trademarks, copyrights, or other intellectual property rights covering subject matter in this document. Except as expressly provided in any written license agreement from MaxLinear, Inc., the furnishing of this document does not give you any license to these patents, trademarks, copyrights, or other intellectual property.

MaxLinear, the MaxLinear logo, and any MaxLinear trademarks, MxL, Full-Spectrum Capture, FSC, G.now, AirPHY and the MaxLinear logo are all on the products sold, are all trademarks of MaxLinear, Inc. or one of MaxLinear's subsidiaries in the U.S.A. and other countries. All rights reserved. Other company trademarks and product names appearing herein are the property of their respective owners.

## Looking for pricing, stock, or lifecycle information?

Click below to explore more details on WIN SOURCE:

-  [View XR3077XIDTR-F on WIN SOURCE](#)
-  [MaxLinear Inc Information](#)

## Optimize Your Supply Chain with WIN SOURCE Solutions

-  Global Sourcing Solution
-  Obsolete Management
-  Cost Control Management
-  Shortage Management
-  Alternative Solution
-  Excess Inventory Management