

TPS92511 500-mA, 65-V Common Anode Constant Current Buck LED Driver Without External Current Sensing Resistor

1 Features

- Wide Input Voltage Range: 4.5 V to 65 V
- Requires NO External Current Sensing Resistor
- Requires NO External Loop Compensation
- Ease of Use, Needs Minimum 5 Components
- 1000:1 Contrast Ratio Feasible
- Single Layer PCB Feasible
- Can Work as High Voltage Buck Regulators
- Can Work as Linear Current Shunt Regulators
- Integrated Low-side N-channel MOSFET
- LED Current Programmable up to 0.5 A
- Typically $\pm 3.6\%$ LED Current Accuracy
- Switching Frequency Programmable From 50 kHz to 500 kHz
- Current Limit Protection
- VCC Under-voltage Lock-out
- Thermal Shutdown Protection
- Support Analog Dimming and Thermal Foldback
- Power Enhanced SOIC-8 Exposed Thermal Pad Package (HSOP-8)

2 Applications

- High Power LED Driver
- Architectural Lighting
- Office Troffer
- Automotive Lighting
- MR-16 LED Lamp

Simplified Application

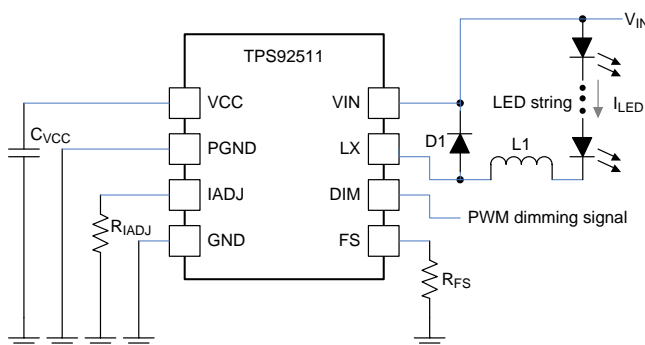

3 Description

The TPS92511 is an easy to use 65V constant current buck converter for driving a single LED string with current up to 0.5A and efficiency up to 95%. Only 5 external components are required for basic operation and single layer PCB layout is feasible because of the integration of a N-MOSFET, no external current sensing resistor, no external compensation and the proper terminal assignment. A high-value external resistor programs the LED current so that fine tuning of the LED current can be achieved. Another high-value external resistor programs a constant switching frequency from 50kHz to 500kHz. EMI design becomes easier as a result of constant switching frequency. The TPS92511 provides a wide input voltage range from 4.5V to 65V. By adding simple external circuits, the device can handle applications with even higher input voltages.

The TPS92511 employs a proprietary control scheme to regulate the LED current without the need of sensing the LED current directly. It applies a floating buck topology with a low-side N-channel power MOSFET, which does not need boot-strapping capacitor. For multiple channel systems, the floating buck topology together with the proprietary control scheme allows a common-anode connection of the LED strings without an external current sensing network. This significantly reduces the number of wiring and as well as overall manufacturing cost.

The TPS92511 has very fast PWM dimming response time. For example, if the switching frequency is 500 kHz, the minimum DIM pulse width is 6 μ s and the dimming frequency is 150Hz, a contrast ratio of more than 1000:1 can be achieved.

The TPS92511 is available in the Power Enhanced SOIC-8 exposed thermal pad package.

Device Information⁽¹⁾

PART NUMBER	PACKAGE	BODY SIZE (NOM)
TPS92511	HSOP (8)	4.89mm x 3.90mm

(1) For all available packages, see the orderable addendum at the end of the datasheet.



Table of Contents

1 Features	1	7.3 Feature Description.....	10
2 Applications	1	7.4 Device Functional Modes.....	17
3 Description	1	8 Application and Implementation	18
4 Revision History	2	8.1 Application Information.....	18
5 Pin Configuration and Functions	3	8.2 Typical Application	18
6 Specifications	4	9 Power Supply Recommendation	21
6.1 Absolute Maximum Ratings	4	10 Layout	22
6.2 Handling Ratings.....	4	10.1 Layout Guidelines	22
6.3 Recommended Operating Conditions	4	10.2 Layout Example	22
6.4 Thermal Information	4	11 Device and Documentation Support	23
6.5 Electrical Characteristics.....	5	11.1 Trademarks	23
6.6 Typical Characteristics.....	6	11.2 Electrostatic Discharge Caution.....	23
7 Detailed Description	8	11.3 Glossary	23
7.1 Overview	8	12 Mechanical, Packaging, and Orderable Information	23
7.2 Functional Block Diagram	9		

4 Revision History

Changes from Original (March 2014) to Revision A	Page
• Corrected figure number sequencing	1
• Updated the Device Information Table	1
• Changed Terminal to Pin.....	3

5 Pin Configuration and Functions

**DDA (SO THERMAL PAD) PACKAGE
8 PINS
(TOP VIEW)**

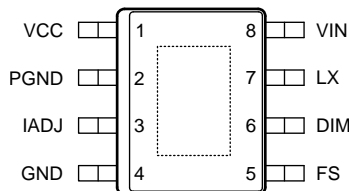

Pin Functions

PIN		DESCRIPTION
NAME	NO.	
DIM	6	PWM Dimming Control. Apply logic level PWM signal to this pin dims the LED string. This pin is internally pulled up.
FS	5	Switching Frequency Setting. An external resistor R_{FS} connecting the FS pin to ground programs the switching frequency from 50 kHz to 500 kHz.
GND	4	Analog Signal Ground.
IADJ	3	Average LED Current Setting. An external resistor R_{IADJ} connecting the IADJ pin to ground programs the average LED current.
LX	7	Integrated MOSFET Drain. Internally connected to the drain of the integrated MOSFET. Connect this pin to the output inductor and anode of the Schottky diode.
PGND	2	Power Ground. Must be connected to the GND pin for normal operation. The PGND and GND pins are not internally shorted.
VCC	1	Internal Regulator Output. Typically regulated to 5.4 V. Connect a capacitor of larger than 1 μ F between the VCC and GND pins.
VIN	8	Input Voltage. Supply pin to the device. The input voltage range is from 4.5 V to 65 V.
Thermal pad		Thermal Connection Pad. Connect to a ground plane for heat dissipation.

6 Specifications

6.1 Absolute Maximum Ratings ⁽¹⁾

Unless otherwise specified, $T_J = T_A = 25^\circ\text{C}$

		MIN	NOM	MAX	UNIT
Pin voltage range	VIN to GND	-0.3		65	V
	VIN to GND (Transient)	-0.3		67	V
	LX to PGND	-0.3		65	V
	LX to PGND (Transient)	-3(2ns)		67	V
	FS, IADJ to GND	-0.3		5	V
	DIM to GND	-0.3		6	V
	VCC to GND	-0.3		7	V
Temperature range	Operating junction temperature range, T_J	-40		Internally limited	$^\circ\text{C}$

(1) Absolute Maximum Ratings are limits beyond which damage to the device may occur. Operating Ratings are conditions under which operation of the device is intended to be functional. For specified specifications and test conditions, see the Electrical Characteristics.

6.2 Handling Ratings

		MIN	MAX	UNIT
T_{stg}	Storage temperature range	-65	150	$^\circ\text{C}$
$V_{\text{ESD}}^{(1)}$	Human Body Model (HBM) ESD stress voltage ⁽²⁾		1.5	kV
	Charged Device Model (CDM) ESD stress voltage ⁽³⁾		1.5	kV

- (1) Electrostatic discharge (ESD) to measure device sensitivity and immunity to damage caused by assembly line electrostatic discharges in to the device.
- (2) Level listed above is the passing level per ANSI, ESDA, and JEDEC JS-001. JEDEC document JEP155 states that 500-V HBM allows safe manufacturing with a standard ESD control process.
- (3) Level listed above is the passing level per EIA-JEDEC JESD22-C101. JEDEC document JEP157 states that 250-V CDM allows safe manufacturing with a standard ESD control process.

6.3 Recommended Operating Conditions

		MIN	NOM	MAX	UNIT
V_{IN}	Supply voltage range	4.5		65	V
T_A	Operating free air temperature	-40		125	$^\circ\text{C}$
T_J	Operating junction temperature	-40		125	$^\circ\text{C}$

6.4 Thermal Information

THERMAL METRIC ⁽¹⁾		TPS92511		UNIT
		DDA		
		8 PINS		
$R_{\theta\text{JA}}$	Junction-to-ambient thermal resistance	59.9		$^\circ\text{C}/\text{W}$
$R_{\theta\text{Jctop}}$	Junction-to-case (top) thermal resistance	59.1		
$R_{\theta\text{JB}}$	Junction-to-board thermal resistance	30.6		
Ψ_{JT}	Junction-to-top characterization parameter	11.0		
Ψ_{JB}	Junction-to-board characterization parameter	30.5		
$R_{\theta\text{Jcbot}}$	Junction-to-case (bottom) thermal resistance	4.2		

(1) For more information about traditional and new thermal metrics, see the *IC Package Thermal Metrics* application report, [SPRA953](#).

6.5 Electrical Characteristics

 Unless otherwise specified, $-40^{\circ}\text{C} \leq T_J = T_A \leq 125^{\circ}\text{C}$, $V_{IN} = 48\text{ V}$

PARAMETER		CONDITIONS	MIN	TYP	MAX	UNIT
SYSTEM						
$I_{IN-DIM-HIGH}$	VIN Operating Current	$4.5\text{ V} \leq V_{IN} \leq 65\text{ V}$, $R_{IADJ} = 3\text{ k}\Omega$, $V_{DIM} = \text{High}$		2.8	3.15	mA
$I_{IN-DIM-LOW}$	VIN Standby Current	$4.5\text{ V} \leq V_{IN} \leq 65\text{ V}$, $R_{IADJ} = 3\text{ k}\Omega$, $V_{DIM} = \text{Low}$		2.3	2.7	mA
I_{LX-OFF}	LX Pin Current	Main switch turned OFF, $V_{LX} = V_{IN} = 65\text{ V}$		0.1	1.0	μA
I_{LED}	Average LED Current	$V_{FS} = 4.6\text{V}$, $R_{IADJ} = 3\text{ k}\Omega$, $T_A = 25^{\circ}\text{C}$	484	502	520	mA
		$V_{FS} = 4.6\text{V}$, $R_{IADJ} = 3\text{ k}\Omega$	477	502	528	mA
		$V_{FS} = 4.6\text{V}$, $R_{IADJ} = 6\text{ k}\Omega$, $T_A = 25^{\circ}\text{C}$	236	249	262	mA
		$V_{FS} = 4.6\text{V}$, $R_{IADJ} = 6\text{ k}\Omega$	233	249	268	mA
		$V_{FS} = 4.6\text{V}$, $R_{IADJ} = 10\text{ k}\Omega$, $T_A = 25^{\circ}\text{C}$	138	149	160	mA
		$V_{FS} = 4.6\text{V}$, $R_{IADJ} = 10\text{ k}\Omega$	133	149	166	mA
V_{IADJ}	IADJ Pin voltage		1.224	1.25	1.278	V
V_{DIM-ON}	DIM Pin Upper Threshold	V_{DIM} Increasing	0.85	1.0	1.25	V
$V_{DIM-OFF}$	DIM Pin Lower Threshold	V_{DIM} Decreasing	0.44			V
$V_{DIM-HYS}$	DIM Pin Threshold Hysteresis			325		mV
f_{SW}	Switching frequency	$R_{FS} = 20\text{ k}\Omega$	450	500	550	kHz
$t_{on(min)}$	Minimum On-time			250	400	ns
INTERNAL REGULATOR						
V_{CC}	VCC Regulated Output Voltage	$C_{VCC} = 1\text{ }\mu\text{F}$, no load	4.7	5.4	6.0	V
		$C_{VCC} = 1\text{ }\mu\text{F}$, $V_{IN} = 4.5\text{V}$, 2 mA load	3.7	4.1		V
$V_{CC-UVLO-ON}$	VCC UVLO Upper Threshold	V_{CC} rising	3.50	3.75	4.00	V
$V_{CC-UVLO-OFF}$	VCC UVLO Lower Threshold	V_{CC} falling	3.05			V
$V_{CC-UVLO-HYS}$	VCC UVLO Hysteresis			275		mV
INTEGRATED MOSFET						
R_{LX}	Resistance Across LX and GND	Main Switch Turned ON, $T_A = 25^{\circ}\text{C}$		1.4	2.15	Ω
THERMAL SHUTDOWN						
T_{SD}	Thermal shutdown temperature	T_J Rising		165		$^{\circ}\text{C}$
T_{SD-HYS}	Thermal shutdown hysteresis	T_J Falling		10		

6.6 Typical Characteristics

Unless otherwise specified, all curves are taken at $V_{IN} = 48V$ with configuration in the application circuit for driving 12 LEDs with $I_{LED} = 0.5A$ and $f_{SW} = 300\text{ kHz}$ as shown in this datasheet, and $T_A = 25^\circ C$.

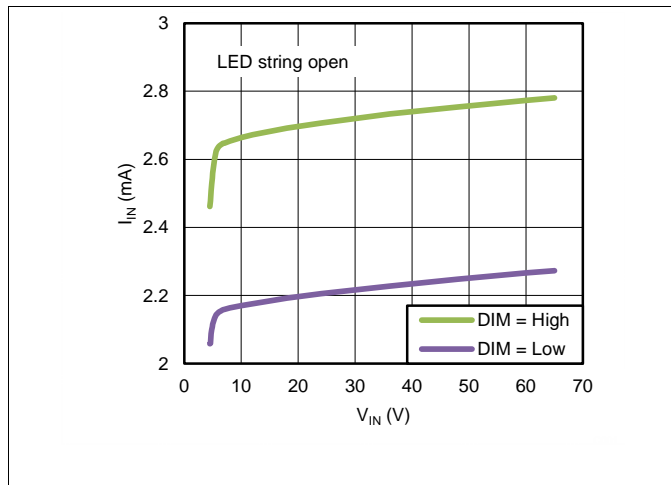

Figure 1. I_{IN} vs V_{IN}

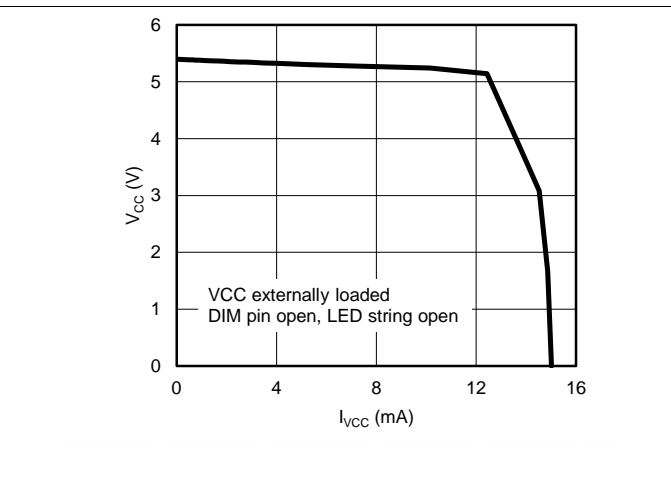

Figure 2. V_{CC} vs I_{VCC}

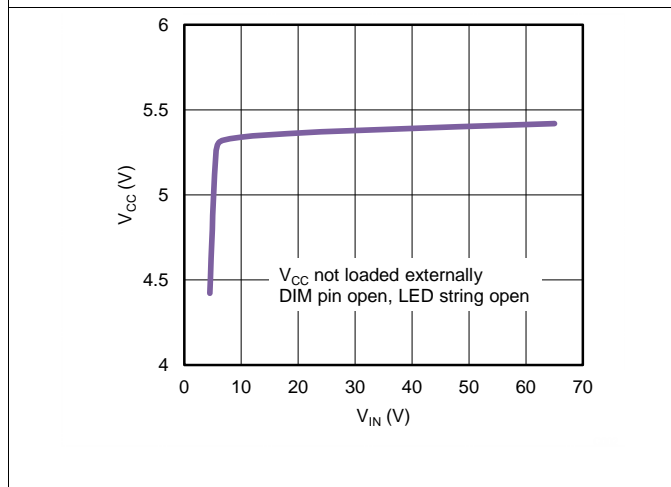

Figure 3. V_{CC} vs V_{IN}

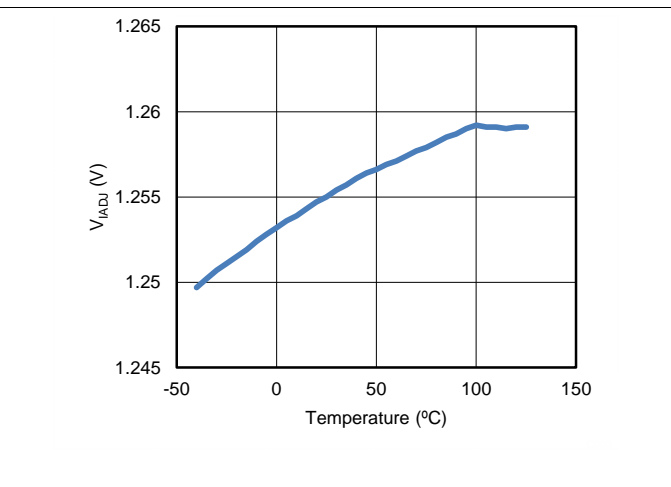

Figure 4. V_{IADJ} vs Temperature

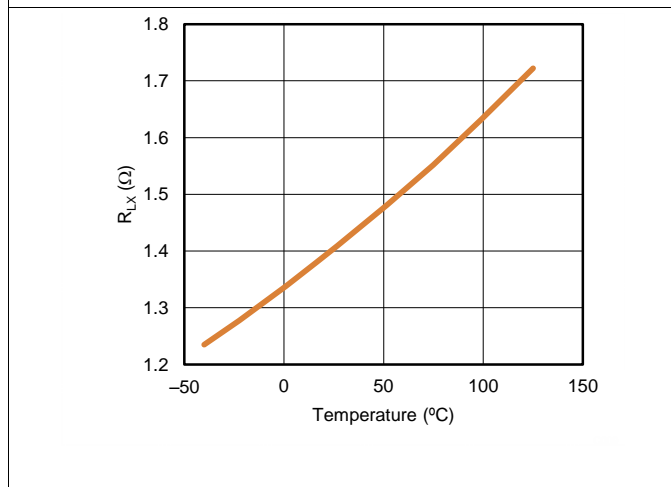

Figure 5. R_{LX} vs Temperature

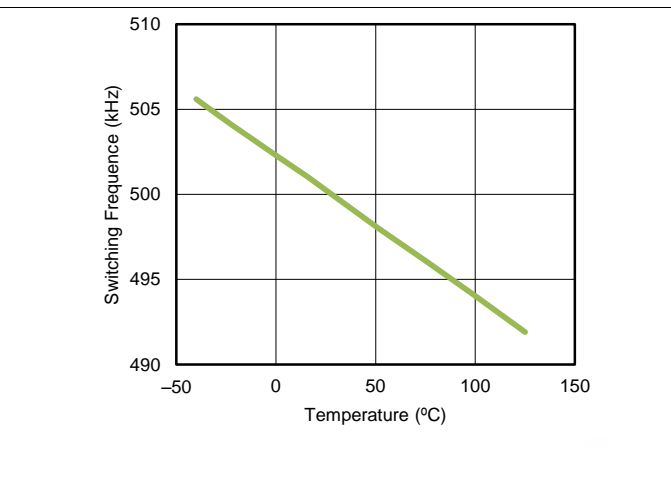

Figure 6. f_{SW} vs Temperature

Typical Characteristics (continued)

Unless otherwise specified, all curves are taken at $V_{IN} = 48V$ with configuration in the application circuit for driving 12 LEDs with $I_{LED} = 0.5A$ and $f_{SW} = 300\text{ kHz}$ as shown in this datasheet, and $T_A = 25^\circ C$.

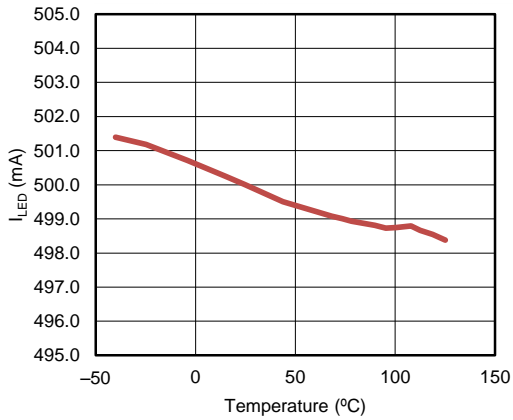

Figure 7. I_{LED} at 500 mA vs Temperature

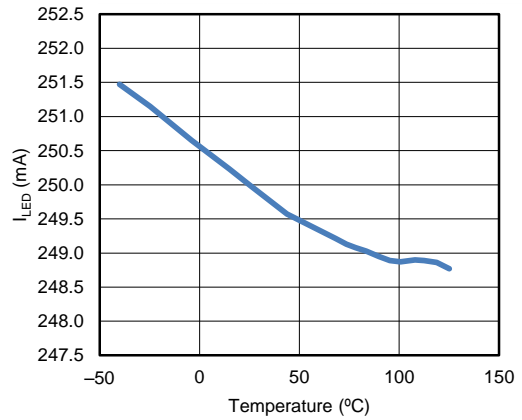

Figure 8. I_{LED} at 250 mA vs Temperature

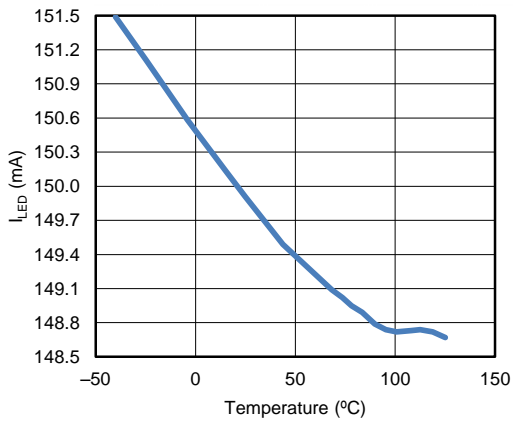

Figure 9. I_{LED} at 150 mA vs Temperature

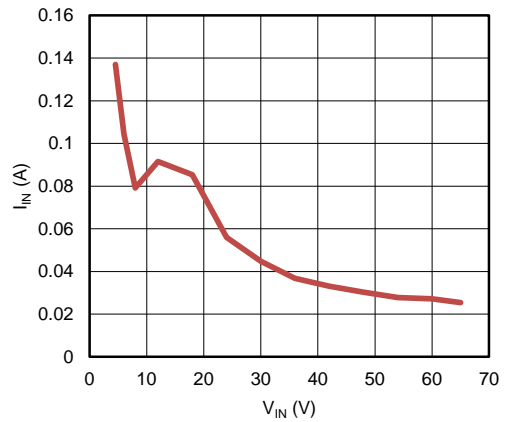

Figure 10. I_{IN} vs V_{IN} at LED Short

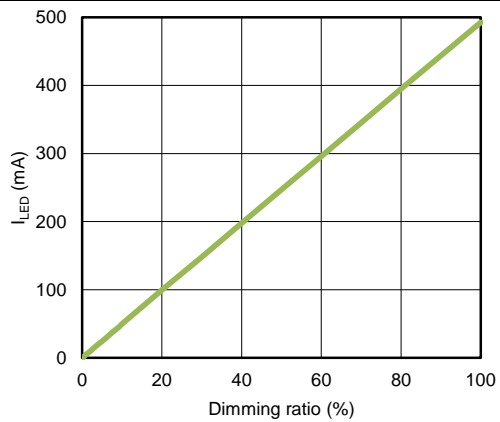

Figure 11. PWM Dimming Linearity (0-100%) ($f_{SW} = 500\text{kHz}$, $L1 = 68\ \mu\text{H}$)

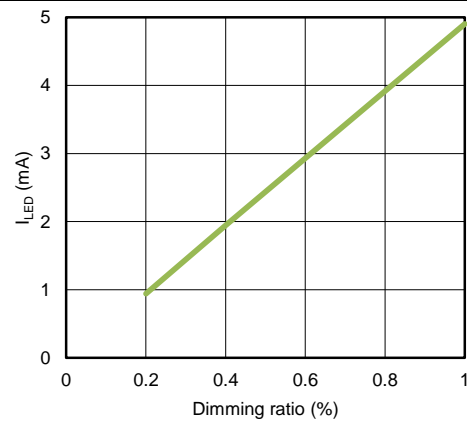

Figure 12. PWM Dimming Linearity (under 1%) ($f_{SW} = 500\text{kHz}$, $L1 = 68\ \mu\text{H}$)

7 Detailed Description

7.1 Overview

The TPS92511 is an easy to use constant current buck converter for driving a single LED string with current up to 0.5A and efficiency up to 95%. Only 5 external components are required for basic operation and single layer PCB layout is feasible because of the integration of a N-MOSFET, no external current sensing resistor, no external compensation and the proper pin assignment. A high-value external resistor programs the LED current so that fine tuning of the LED current can be achieved. Another high-value external resistor programs a constant switching frequency from 50kHz to 500kHz. As a result of constant switching frequency, EMI design becomes easy. The TPS92511 provides a wide input voltage range from 4.5V to 65V. By adding simple external circuits, it can handle applications with even higher input voltages.

The TPS92511 employs a proprietary Pulse-Level-Modulation (PLM) control scheme under continuous conduction mode (CCM) to regulate the LED current without the need of sensing the LED current directly. It applies a floating buck topology with a low-side N-channel power MOSFET, which does not need boot-strapping capacitor, so that driving LED string under drop-out conditions and very high input voltages are feasible. For multiple channel systems, the floating buck topology without external current sensing network together with the proprietary control scheme allows a common-anode connection of the LED strings without external current sensing network. This saves high-side current sensing wirings for separate driver boards and LED board systems and significantly reduces the number of wiring, which can lower overall manufacturing cost.

The TPS92511 has very fast PWM dimming response time. There is almost no delay between the DIM pin voltage rising edge and the start of the LED current conduction, so it can dim down to nearly zero current. In order to maintain good dimming linearity, the minimum LED current pulse width is suggested to be three switching cycles. For example, if the switching frequency is 500 kHz, the minimum DIM pulse width is 6 μ s and the dimming frequency is 150Hz, a contrast ratio of more than 1000:1 can be achieved.

7.2 Functional Block Diagram

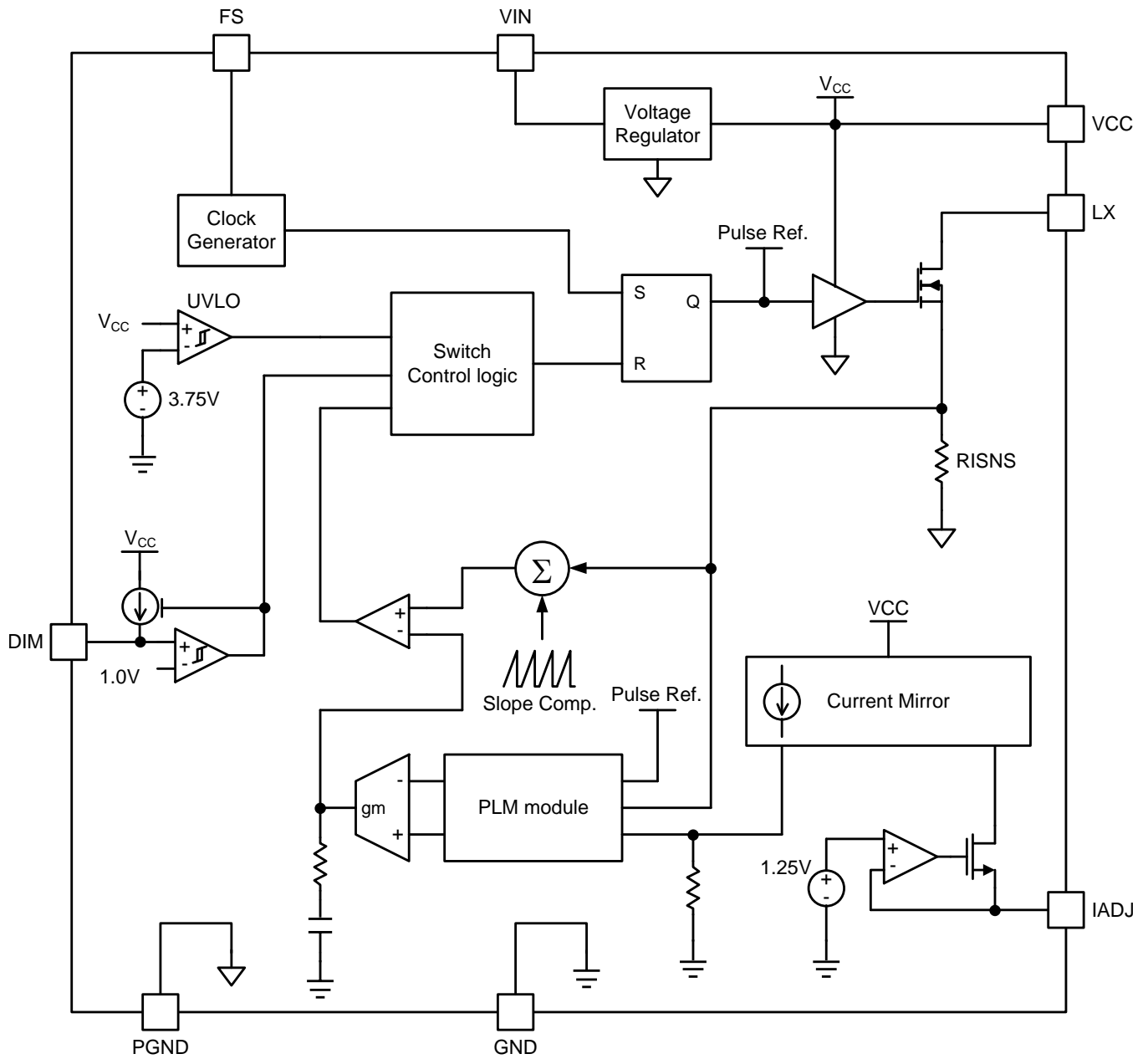

7.3 Feature Description

7.3.1 Pulse Level Modulation (PLM) Control

A proprietary Pulse-Level-Modulation (PLM) control method is used in the TPS92511. It can regulate the average LED current by sensing only the inductor current at the on-period (Figure 13). The integrated MOSFET and the sensing and control circuits in the TPS92511 implement the whole PLM control internally so the control does not suffer from tolerance and noise issues that may be coming from external components. As compared with the conventional method which regulates average LED current by sensing the current over the entire switching cycle, the power dissipation on the sensing circuit in PLM is much lower. For example, consider a duty cycle of 0.5, the power dissipation on current sensing in PLM can be reduced by half. PLM requires no external loop compensation circuit. Besides, the accuracy of the regulated LED current is high (typically $\pm 3.5\%$ in the TPS92511).

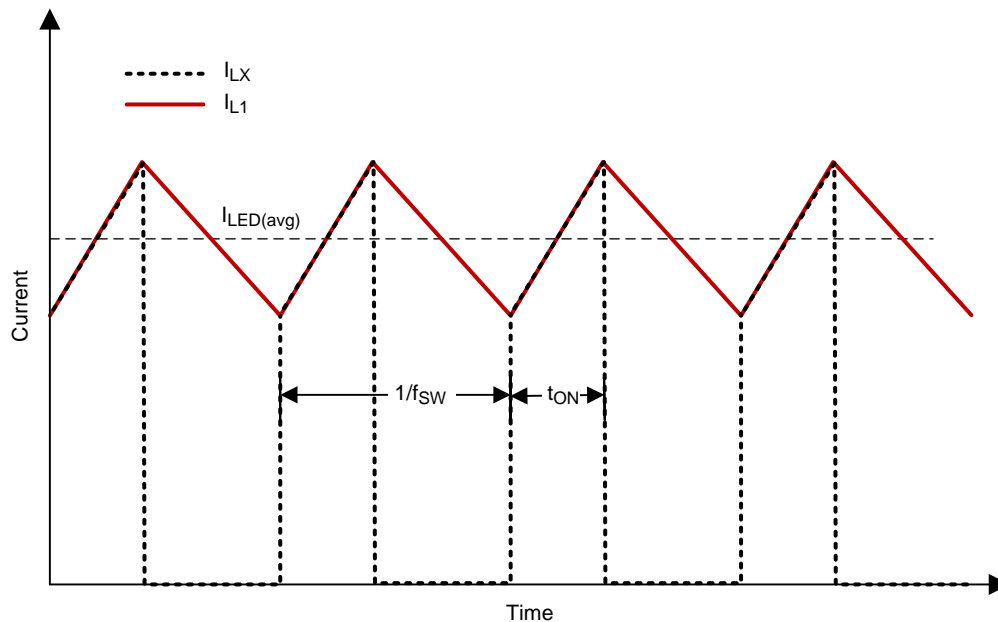

Figure 13. Waveforms of a Floating Buck LED Driver with PLM

7.3.2 Pulse Level Modulation (PLM) Operation Principles

The Pulse-Level-Modulation is a patented method to ensure an accurate average output current regulation without the need of direct output current sensing. Figure 13 shows the current waveforms of a typical buck converter under steady state, where, I_{L1} is the inductor current and I_{LX} is the current flowing into the LX pin. For a buck converter operating in steady state, the mid-point of the RAMP portion of I_{L1} equals to the average value of I_{L1} and hence the average LED current $I_{LED(avg)}$. In short, by regulating the mid-point with respect to a precise reference level, PLM achieves LED current regulation by sensing the main MOSFET current solely, instead of the entire cycle of I_{L1} .

7.3.3 PLM Control enable Common-Anode Low-Side Sensing (CALS) Technique to Save Wiring

For multi-channel systems with separated driver boards and LED array boards, the Pulse-Level-Modulation (PLM) control scheme enable Common-Anode Low-Side Current Sensing to save inter-board wirings. Figure 14 shows a conventional configuration with a Low-side switching and High-Side Current Sensing. For an n channel system with separated driver and an LED array boards, $2n$ inter-board wirings are required. For example, an 128-channel system needs 256 inter-board wirings, which implies a high material and manufacturing cost. Figure 15 shows the PLM configuration with Low-side switching and Low-Side Current Sensing. A Common-Anode configuration is used for the LED array board. As shown in the figure, an n channel system with separated driver and LED array boards requires only $n+1$ inter-board wirings. For an 128-channel system, only 129 inter-board wirings are required. The wiring cost is cut by half, and the cost of the end product can be reduced.

Feature Description (continued)

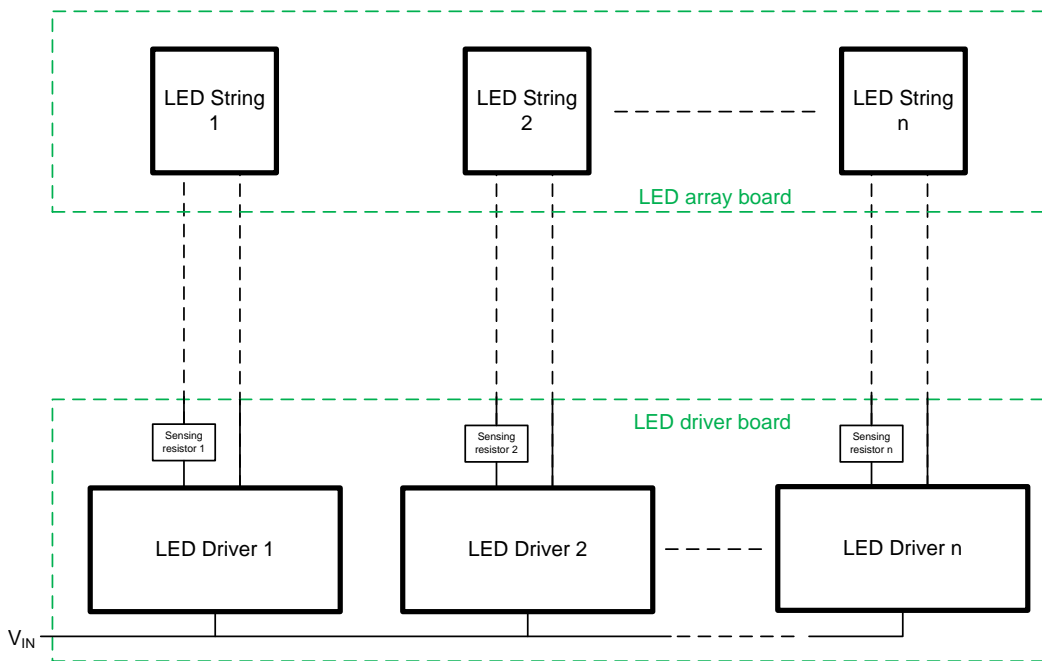

Figure 14. Conventional Configuration with Low-Side Switching and High-Side Current Sensing Requires 2xn Inter-Board Wirings

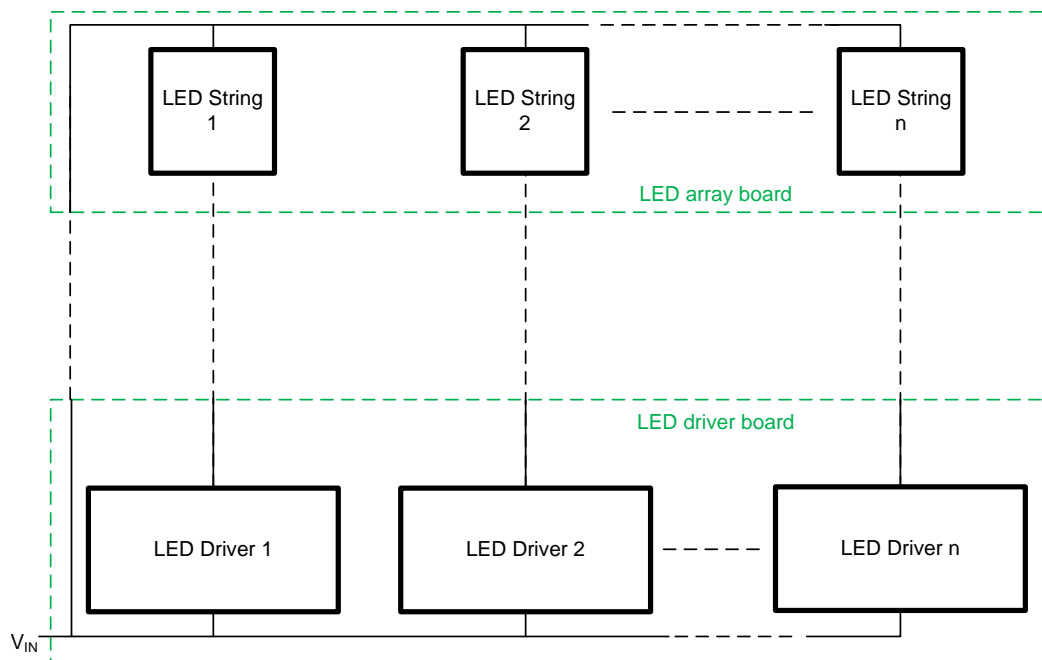

Figure 15. PLM Configuration with Common-Anode Low-Side Switching Requires n+1 Inter-Board Wirings

Feature Description (continued)

7.3.4 Internal Regulator

The TPS92511 integrates an internal voltage regulator for powering internal circuitry. For stability, an external capacitor C_{VCC} of at least 1 μF should be connected between the VCC and PGND pins. The output of the internal regulator V_{CC} is 5.4V when V_{IN} is larger than 6V. If V_{IN} is lower than 6V, V_{CC} decreases. The TPS92511 will trigger the VCC under-voltage lock-out if V_{CC} falls below typically 3.5V. V_{CC} can be used to bias external circuits subject to a loading of maximum 2 mA, while it has a short circuit current limit at typically 16 mA.

7.3.5 Setting The Switching Frequency

The switching frequency f_{SW} of the TPS92511 is programmable in the range of 50 kHz to 500 kHz by a single resistor R_{FS} connecting the FS pin and ground. The following equation shows the relationship between f_{SW} and R_{FS} :

$$f_{SW} = \frac{10 \times 10^6}{R_{FS}} \text{ kHz} \quad (1)$$

Figure 16 plots f_{SW} against R_{FS} . Table 1 shows values of R_{FS} for commonly used switching frequencies.

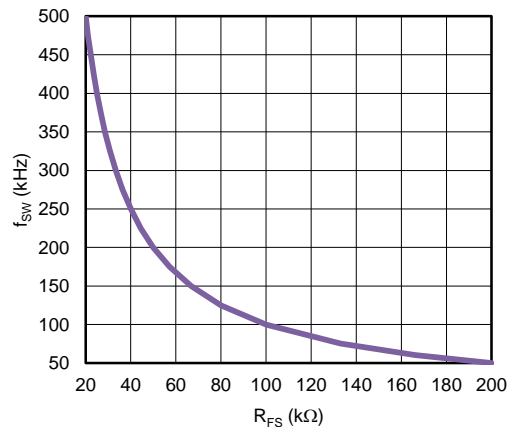

Figure 16. Switching Frequency vs R_{FS}

Table 1. Commonly Used f_{SW} And R_{FS}

f_{SW} (kHz)	R_{FS} (k Ω)
50	200
100	100
300	33.2
500	20

7.3.6 Setting The LED Current

The LED current I_{LED} of the TPS92511 is programmable by a single resistor R_{IADJ} connecting the IADJ pin and ground. The IADJ pin is internally biased to 1.25 V. Equation 2 shows the relationship between I_{LED} and R_{IADJ} :

$$I_{LED} = \frac{1500}{R_{IADJ}} \text{ A} \quad (2)$$

To ensure stability, R_{IADJ} must be less than 30 k Ω , implying a minimum I_{LED} of 50 mA can be programmed. The tolerance of I_{LED} of 150 mA is shown in the ELECTRICAL CHARACTERISTICS. Larger tolerance should be expected for lower I_{LED} . Figure 17 plots I_{LED} against R_{IADJ} . Table 2 shows values of R_{IADJ} for commonly used I_{LED} .

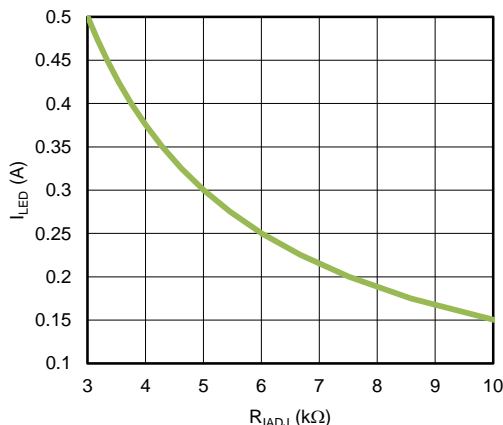

Figure 17. LED Current vs R_{IADJ}

Table 2. Commonly Used I_{LED} And R_{IADJ}

I _{LED} (mA)	R _{IADJ} (kΩ)
150	10
350	4.32
500	3.01

7.3.7 Integrated MOSFET

The TPS92511 integrates a N-channel power MOSFET, the drain of which is connected to the LX pin. When the integrated MOSFET is turned on, the resistance across the LX and GND pins is typically 1.4Ω. The integrated MOSFET has a fixed current limit of 1.2A to protect the application circuit during critical operation conditions like short circuit of the LED string. Once the limit is hit, the integrated MOSFET turns off immediately for 34 μs to let the inductor discharge.

The minimum on-time of the integrated MOSFET is 400 ns. It may be hit at a high switching frequency and a high V_{IN}/V_{LED} ratio. Once hit, the I_{LED} regulation may be affected. In the worst case, I_{LED} may be boost up to a level higher than the programmed value, and the LED string and/or the inductor may be damaged as a result. Hence, it is recommended that the ratio between V_{IN} and V_{LED} should be designed under the following constraint:

$$\frac{V_{LED}}{V_{IN}} \geq 400ns \times f_{SW} \tag{3}$$

7.3.8 Inductor Selection

Operating in the continuous conduction mode (CCM) is required in the TPS92511 application circuit. In the CCM, considering the on-period, the peak-to-peak inductor current ripple (2ΔI_{L1}) is shown in Equation 4.

$$2\Delta I_{L1} = \frac{t_{on}(V_{IN} - V_{LED})}{L_1} \tag{4}$$

Because

$$\frac{V_{LED}}{V_{IN}} = t_{on}f_{SW} \tag{5}$$

L₁ can be a function of V_{IN}, V_{LED}, f_{SW} and ΔI_{L1} as shown in Equation 6 .

$$L_1 = \frac{(V_{IN} - V_{LED})V_{LED}}{2\Delta I_{L1}V_{IN}f_{SW}} \tag{6}$$

The value of L₁ is selected by designers with the consideration of all above parameters. The minimum L₁ calculated by the following equation is a good starting point for designing L₁:

$$L_1 > 1\mu\text{H}\Omega^{-1} \times \frac{R_{\text{FS}}R_{\text{IADJ}}}{10^6} \quad (7)$$

The following table shows some typical examples of using R_{FS} and R_{IADJ} to estimate the minimum L_1 :

Table 3. Estimation Of Minimum L_1 Using R_{FS} And R_{IADJ}

R_{FS} (k Ω)	R_{IADJ} (k Ω)	Estimated Minimum L_1 (μH)	Recommended L_1 (μH)
100	10	1000	1000
33.2	3.01	100	100
20	4.32	86	100
20	3.01	60	68

To maintain the CCM, ΔI_{L_1} must be smaller than the average LED current $I_{\text{LED(avg)}}$. Hence, the minimum inductance used is:

$$L_{1(\text{min})} = \frac{(V_{\text{IN}} - V_{\text{LED}})V_{\text{LED}}}{2I_{\text{LED(avg)}}V_{\text{IN}}f_{\text{SW}}} \quad (8)$$

In the absence of output capacitors, the TPS92511 can maintain a continuous I_{LED} throughout the entire switching cycle because in such case the inductor current is the same as I_{LED} (floating buck topology operating in the CCM). However, the LED peak current must not exceed the rated current of the LED. The peak LED current can be found by the following equation:

$$I_{\text{LED(peak)}} = I_{\text{LED(avg)}} + \frac{(V_{\text{IN}} - V_{\text{LED}})V_{\text{LED}}}{2L_1V_{\text{IN}}f_{\text{SW}}} \quad (9)$$

7.3.9 Integrated MOSFET Current Limit

The current limit of the integrated MOSFET is internally fixed at 1.2A to protect the LED string, the inductor and the integrated MOSFET from overdriven. Once triggered, the integrated MOSFET turns off immediately for 34 μs to let the inductor to discharge. The triggering of the current limit cycles repetitively until all overdriven conditions disappear.

7.3.10 PWM Dimming Control

The TPS92511 implements PWM dimming by applying a PWM dimming signal to the DIM pin. A low input applying to the DIM pin disables the switching of the integrated MOSFET, and as a result discharges the inductor and then turns off the LED string. To turn on the LED string, the DIM pin should be connected to high or left open (since it is internally pulled high by a current of typically 40 μA and 90 μA when the DIM pin is low and high respectively). The PWM dimming frequency is recommended to be lower than $0.1f_{\text{SW}}$ to ensure normal operation.

7.3.11 Analog Dimming

Analog dimming can be implemented by injecting a current to R_{IADJ} (Figure 18) and as a result reduces the current of the IADJ pin, I_{ADJ} , which is controlled internally by the TPS92511 to bias the voltage on the IADJ pin to be 1.25V. If the CCM can be maintained, the minimum I_{ADJ} can achieve 15 μA , which refers to an I_{LED} of 18 mA. If I_{ADJ} is further decreased, I_{LED} may not follow due to the presence of the minimum on-time of the integrated MOSFET. If the CCM cannot be maintained, I_{LED} can still decrease monotonically with I_{ADJ} . However, if good line and load regulations are required, the CCM should be maintained by using a large inductance.

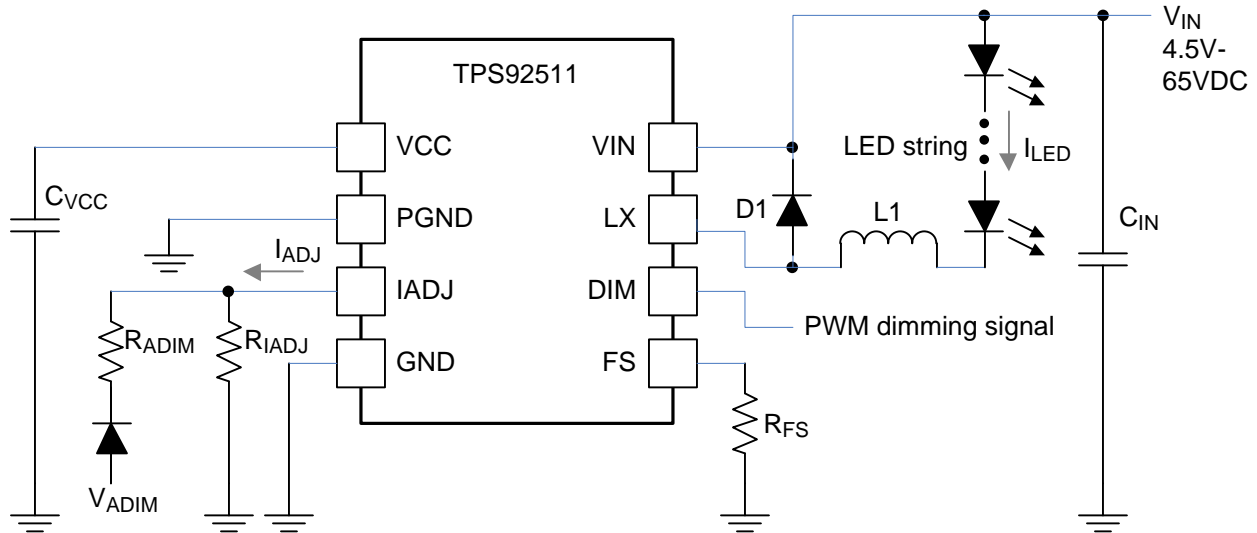

Figure 18. Circuit Configuration for Analog Dimming

7.3.12 High Voltage Buck Configuration

The TPS92511 can handle applications with an input voltage higher than 65V, which is the maximum V_{IN} of the recommended operating condition of the TPS92511, by adding an external high voltage N-channel MOSFET to the application circuit as shown in Figure 19. PWM dimming can be implemented in this circuit without additional efforts, and analog dimming is also feasible by referencing to additional circuits shown in Figure 18.

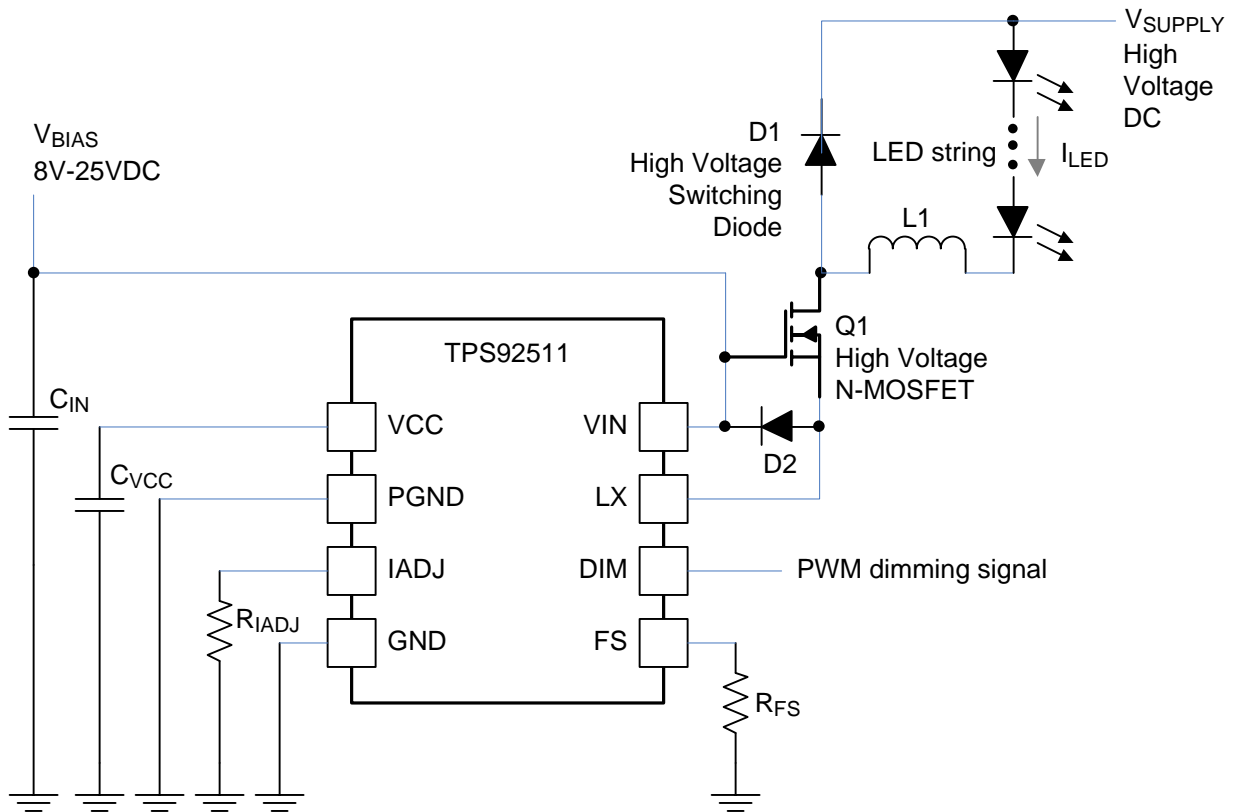

Figure 19. Circuit Configuration for Very High Voltage Buck

7.3.13 Thermal Foldback

Thermal foldback is useful to prevent over-temperature of LEDs during operation by sensing the temperature of LEDs and, if the sensed temperature is high, reducing I_{LED} to decrease the power and as well as the temperature of LEDs. Thanks to the feature of analog dimming, thermal foldback can be implemented by embedding a negative temperature coefficient (NTC) resistor, R_{NTC} , into a circuit as shown in Figure 20. When the sensed temperature increases, R_{NTC} decreases and thus the emitter current of Q_{T1} increases to reduce I_{LED} by means of analog dimming. The resistor R_{TF} can adjust the loop gain of the thermal foldback control loop, which should be high enough to avoid oscillation and maintain stability.

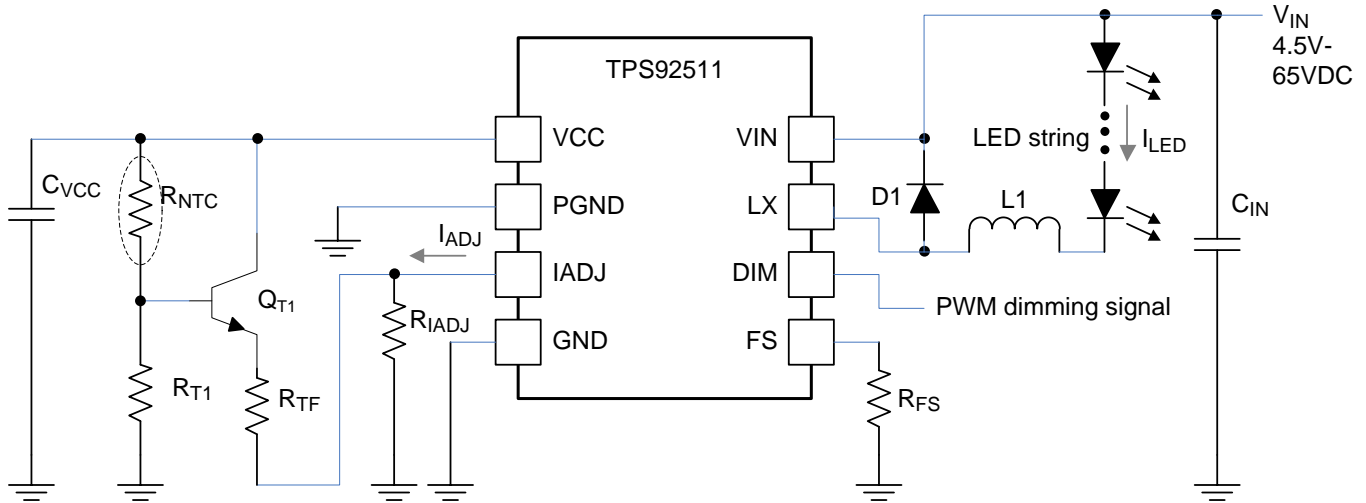

Figure 20. Circuit Configuration for Thermal Foldback

7.3.14 EMI Consideration

Conductive and radiative EMI can be major concerns for lighting applications. The TPS92511 application circuit can be designed for the EN 55022 class B standard by adding a few external components, as shown in Figure 21. The input filter which consists of an inductor L_2 and two capacitors C_{IN2} and C_{IN3} takes care of the conductive EMI, while the output capacitor C_{LED} and the ferrite bead FB_1 which inserts between the LX pin and D_1 take care of the radiative EMI.

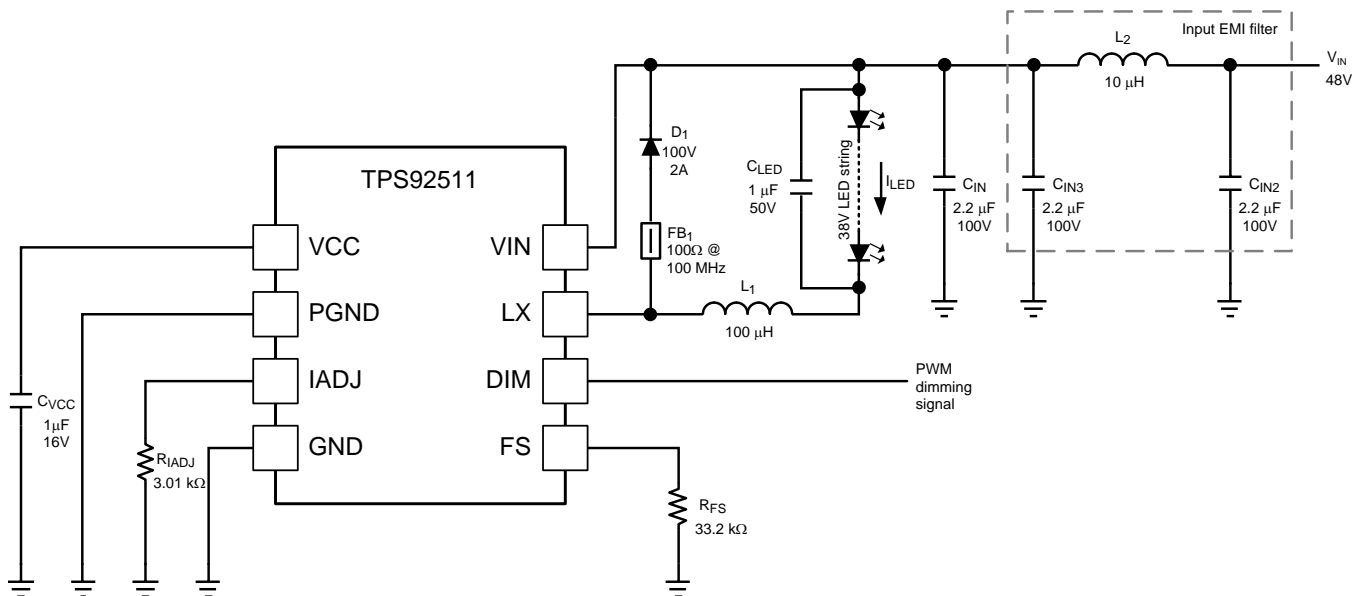

Figure 21. Circuit Configuration with EMI Design Consideration

7.4 Device Functional Modes

7.4.1 Operation with $V_{IN} < 4.5\text{ V}$ (minimum V_{IN})

For the typical application circuit, when the input voltage drops so that the VCC voltage regulator is under drop-out mode, and the VCC voltage drops below the “VCC UVLO Lower Threshold” (typically 3.48V), the switching of the main MOSFET is stopped, and the LED current will become zero. At the same time, the voltages of both the FS and IADJ pins will become zero.

When the input voltage increases from zero and the VCC voltage is increased to cross over the “VCC UVLO Upper Threshold” (typically 3.75V), the voltages on the FS and IADJ pins will rise to their regulation voltage (typically 1.25V), the switching of the main MOSFET is started upon the DIM pin voltage is HIGH, and the LED current will ramp up to its preset value set by R_{IADJ} .

7.4.2 Operation with DIM control

For the typical application circuit, when the VCC voltage is not under UVLO condition, the switching of the main MOSFET is enabled and the LED current is conducted if the DIM pin voltage is higher than the “DIM Pin Upper Threshold” (typically 1V).

Alternatively, the switching is disabled and the LED current is cut off if the voltage of the DIM pin is lower than the “DIM Pin Lower Threshold” (typically 0.675V).

7.4.3 Linear Mode

When the VCC voltage is not under UVLO condition and the voltage on the FS pin is forced to be higher than 4.2V but lower than 5V, the switching of the main MOSFET is disabled, and the TPS92511 is working in the Linear Mode. In the Linear Mode, if the voltage on the DIM pin is higher than the “DIM Pin Upper Threshold” (typically 1V), the TPS92511 will regulate the LX pin in-going current according to the preset value set by R_{IADJ} . Alternatively, if the voltage on the DIM pin is lower than the “DIM Pin Lower Threshold” (typically 0.675V), the LX pin will open and its in-going current will become zero.

Below is the simple configuration to have the TPS92511 working as a linear current shunt regulator.

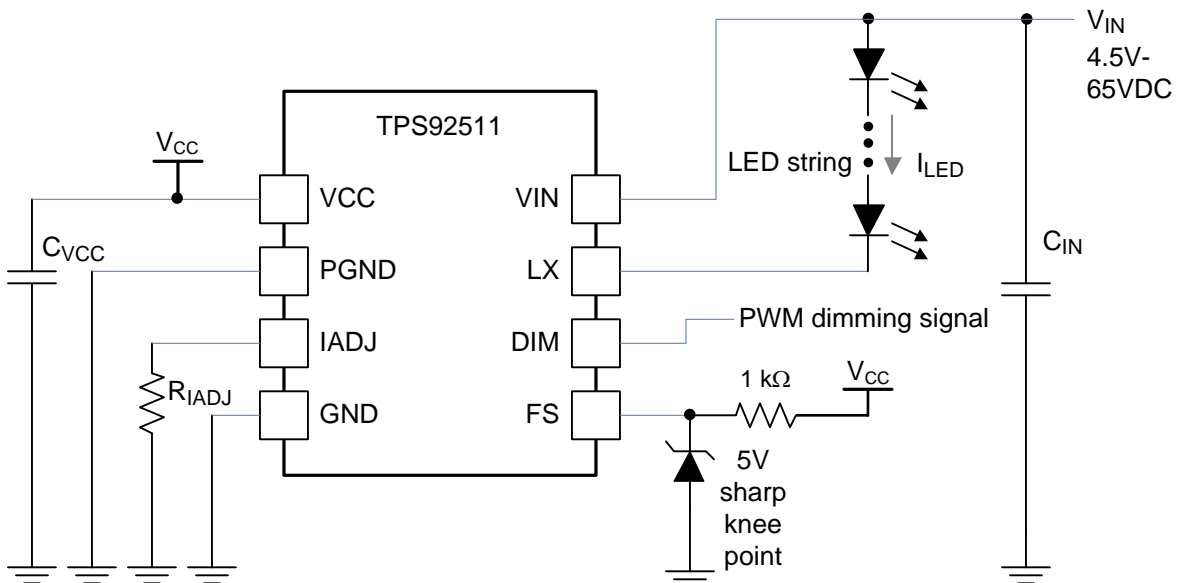

Figure 22. Circuit Configuration for Working as a Linear Current Shunt Regulator

8 Application and Implementation

8.1 Application Information

The TPS92511 is an LED driver which provides a regulated output current to drive a single string of LED with the forward voltage lower than the input voltage. The following procedures design a TPS92511 application circuit with an input voltage of 48V, driving an LED string of 38V at an LED current of 0.5A. The switching frequency is 300 kHz.

8.2 Typical Application

8.2.1 TPS92511 LED driver for 12 LEDs at 0.5A

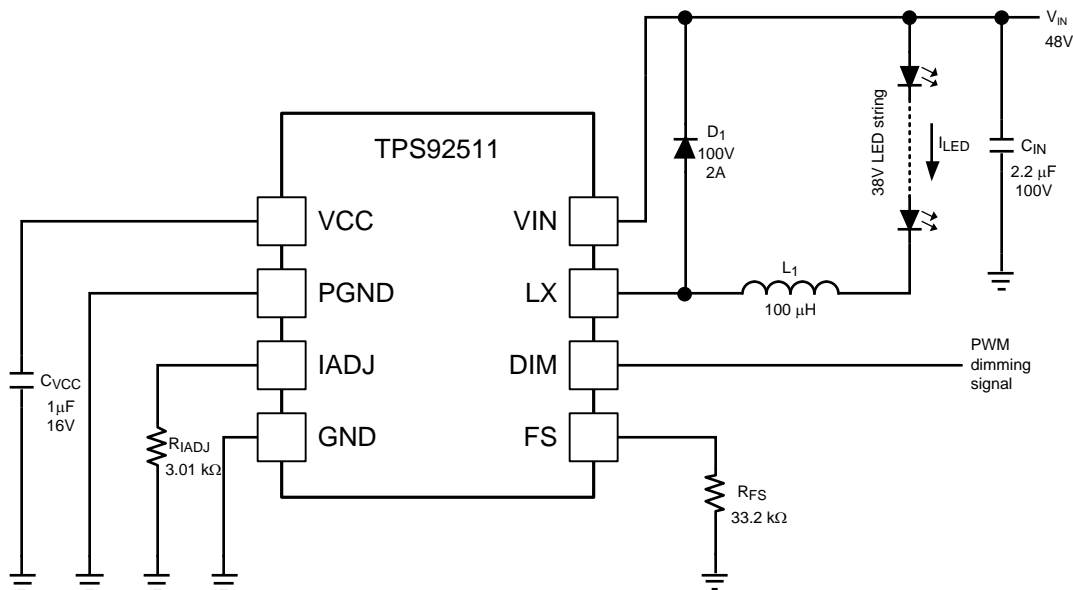

Figure 23. Application Circuit of TPS92511 ($f_{sw} = 300$ kHz and $I_{LED} = 0.5$ A)

Typical Application (continued)

8.2.1.1 Design Requirements

Table 4. Design Parameters

DESIGN PARAMETER	EXAMPLE VALUE
Input voltage range	43V to 53V
LED current	0.5A
LED string forward voltage	38V
Operating frequency	300 kHz

8.2.1.2 Detailed Design Procedure

C_{IN} : The function of the input capacitor C_{IN} is to reduce the input voltage ripple. Ceramic capacitors are recommended owing to the concern of product lifetime. A 100V 2.2 μF ceramic capacitor is selected in this circuit.

C_{VCC} : The capacitor on the VCC pin provides noise filtering and stabilizes the internal regulator. It also prevents false triggering of the VCC UVLO. C_{VCC} is recommended to be a 1 μF good quality and low ESR ceramic capacitor.

D₁ : The diode D₁ should have a reverse voltage larger than V_{IN} in the floating buck topology. In this circuit, a 100V diode is selected.

R_{FS} and R_{IADJ} : In this circuit, the switching frequency and LED current are designed to be 300 kHz and 0.5A. From [Table 1](#) and [Table 2](#), R_{FS} is 33.2 kΩ and R_{IADJ} is 3.01 kΩ.

L₁ : The selection of inductor mainly affects the inductor current ripple. In this circuit, we design the peak to peak inductor current ripple to be 50% of I_{LED}, i.e. 0.25A. From (6), L₁ is calculated to be 106 μH, and a 100 μH inductor is selected.

8.2.1.3 Application Curves

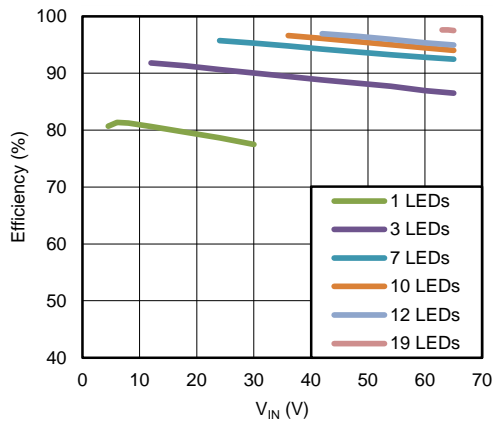

Figure 24. Efficiency vs V_{IN}

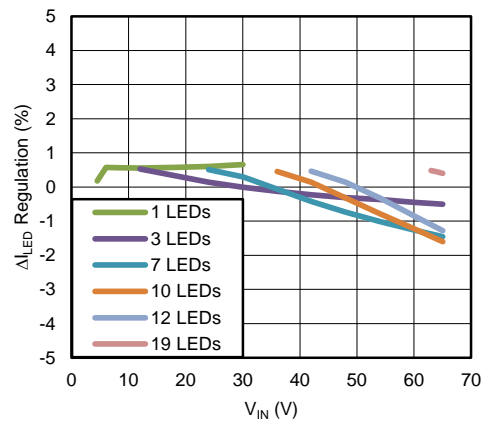

Figure 25. LED Current Regulation vs V_{IN}

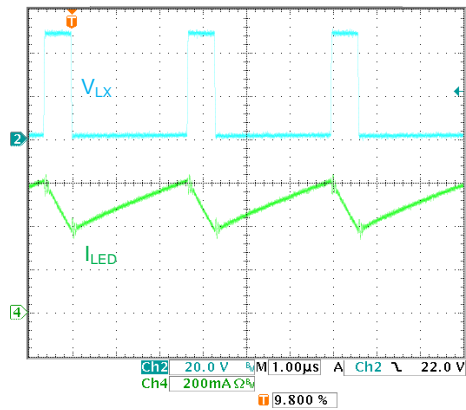

Figure 26. Steady State Operation

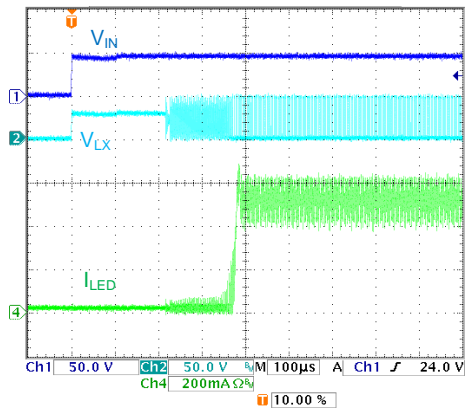

Figure 27. Power Up

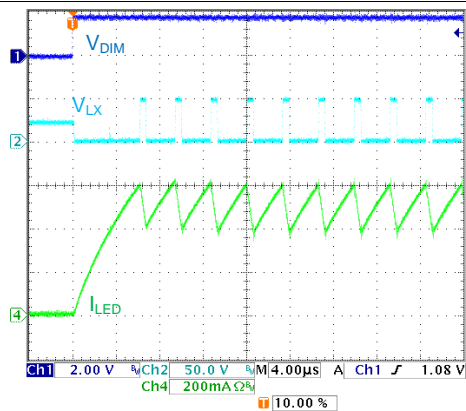

Figure 28. PWM Dimming (V_{DIM} Rising)

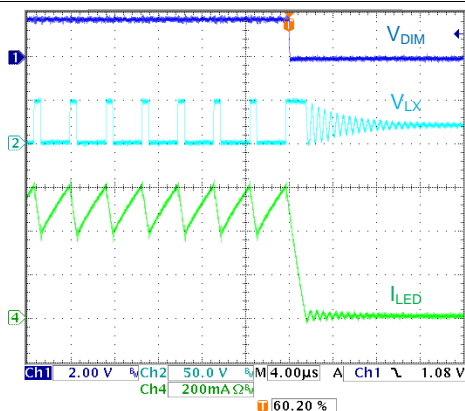
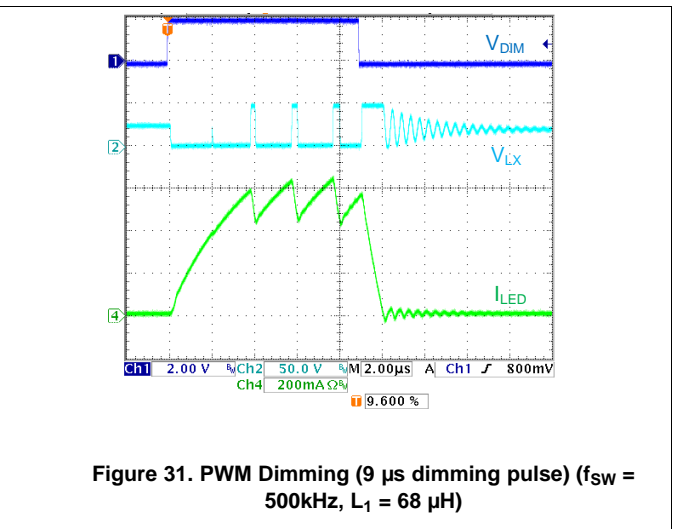
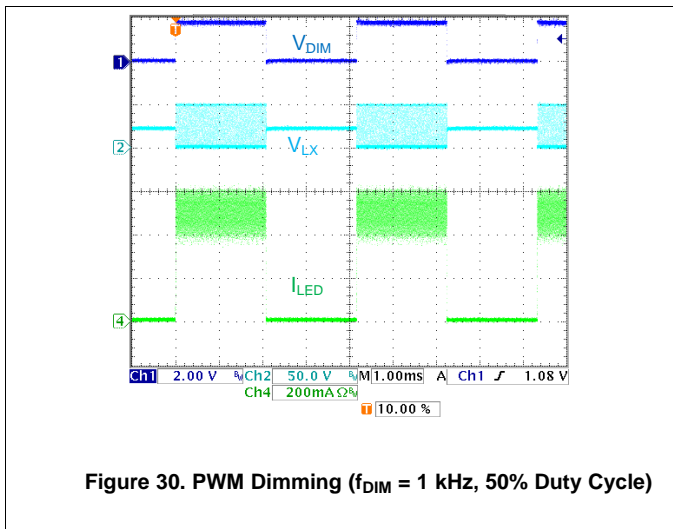

Figure 29. PWM Dimming (V_{DIM} Falling)



9 Power Supply Recommendation

This device is designed to operate from an input voltage supply range between 4.5 V and 65 V. The input supply should be well regulated. If the input supply is located more than a few inches from the TPS92511 application board, additional bulk capacitance may be required in addition to the input capacitor. A ceramic capacitor with a value of 2.2 μF is a typical choice.

10 Layout

10.1 Layout Guidelines

- The PCB layout of the TPS92511 application circuit plays an important role in optimizing the performance.
- The external components should be placed as close to the TPS92511 as possible to minimize resistance and parasitic inductance of copper traces.
- For example, D_1 and L_1 should be near the LX pin, and C_{VCC} should be near the VCC pin, and the connecting copper traces are short and thick.
- The exposed pad of the TPS92511, which is internally connected to the die substrate, should be connect to a ground plane, and the plane should be extended as much as possible on the same copper layer around the TPS92511.
- Using numerous vias beneath the exposed pad to dissipate heat to another copper layer is also a good practice.

10.2 Layout Example

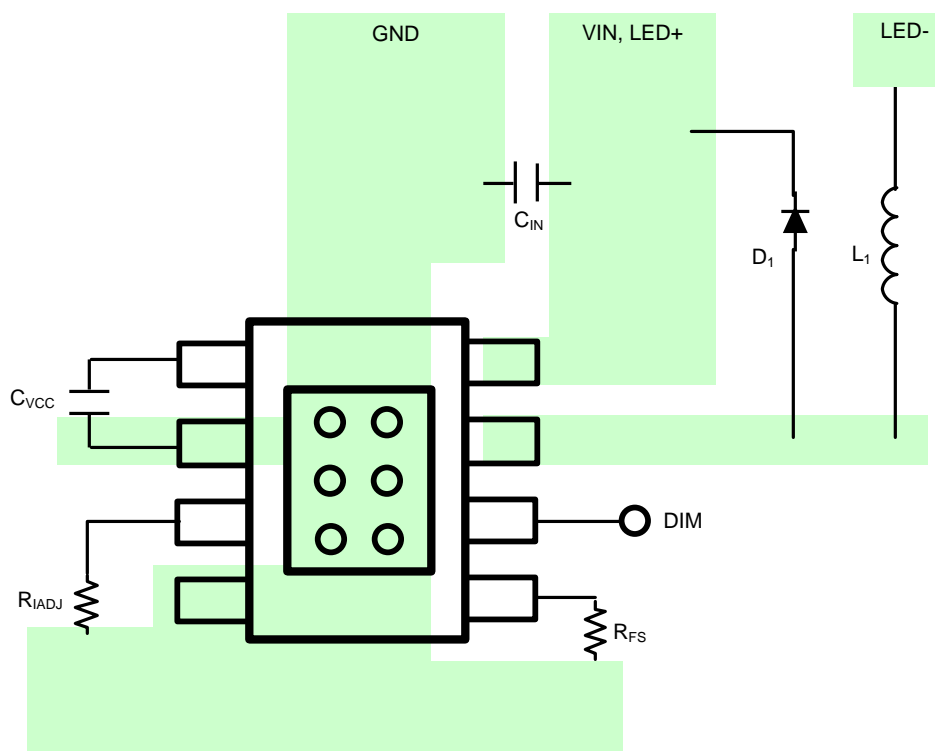

Figure 32. TPS92511 Board Layout

10.2.1 Thermal Consideration

Ψ_{JT} (shown in session 6.4 Thermal Information) is a relatively small value for package with exposed pad since most of the heat is dissipated through the exposed pad to the copper plate of the PCB (assuming optimized PCB layout), relatively little heat goes to the top of the device. The top of the device mold compound temperature is physically close to the device junction temperature.

For example, a 30W output TPS92511 end system at 95% power efficiency (can be estimated from the efficiency curves of Figure 13), power loss is 1.6W. Assuming all the heat is generated from the TPS92511 (which is true for high V_{LED}), and assuming half of the heat generated is dissipated through the top of the device. Now Ψ_{JT} is 11 °C/W, the device junction temperature is estimated to be higher than the package's top-surface temperature by $11 \times 1.6 \times 0.5 = 8.8$ (°C). If the package top-surface temperature is measured to be 90 °C (for example by an IR camera), the device junction temperature is around 99 °C, which is within the 125°C maximum junction temperature requirement with margin.

11 Device and Documentation Support

11.1 Trademarks

All trademarks are the property of their respective owners.

11.2 Electrostatic Discharge Caution



These devices have limited built-in ESD protection. The leads should be shorted together or the device placed in conductive foam during storage or handling to prevent electrostatic damage to the MOS gates.

11.3 Glossary

[SLYZ022](#) — *TI Glossary*.

This glossary lists and explains terms, acronyms and definitions.

12 Mechanical, Packaging, and Orderable Information

The following pages include mechanical packaging and orderable information. This information is the most current data available for the designated devices. This data is subject to change without notice and revision of this document. For browser-based versions of this data sheet, refer to the left-hand navigation.

PACKAGING INFORMATION

Orderable Device	Status (1)	Package Type	Package Drawing	Pins	Package Qty	Eco Plan (2)	Lead finish/ Ball material (6)	MSL Peak Temp (3)	Op Temp (°C)	Device Marking (4/5)	Samples
TPS92511DDA	ACTIVE	SO PowerPAD	DDA	8	95	RoHS & Green	SN	Level-3-260C-168 HR	-40 to 125	92511	Samples
TPS92511DDAR	ACTIVE	SO PowerPAD	DDA	8	2500	RoHS & Green	SN	Level-3-260C-168 HR	-40 to 125	92511	Samples

(1) The marketing status values are defined as follows:

ACTIVE: Product device recommended for new designs.

LIFEBUY: TI has announced that the device will be discontinued, and a lifetime-buy period is in effect.

NRND: Not recommended for new designs. Device is in production to support existing customers, but TI does not recommend using this part in a new design.

PREVIEW: Device has been announced but is not in production. Samples may or may not be available.

OBSOLETE: TI has discontinued the production of the device.

(2) **RoHS:** TI defines "RoHS" to mean semiconductor products that are compliant with the current EU RoHS requirements for all 10 RoHS substances, including the requirement that RoHS substance do not exceed 0.1% by weight in homogeneous materials. Where designed to be soldered at high temperatures, "RoHS" products are suitable for use in specified lead-free processes. TI may reference these types of products as "Pb-Free".

RoHS Exempt: TI defines "RoHS Exempt" to mean products that contain lead but are compliant with EU RoHS pursuant to a specific EU RoHS exemption.

Green: TI defines "Green" to mean the content of Chlorine (Cl) and Bromine (Br) based flame retardants meet JS709B low halogen requirements of <=1000ppm threshold. Antimony trioxide based flame retardants must also meet the <=1000ppm threshold requirement.

(3) MSL, Peak Temp. - The Moisture Sensitivity Level rating according to the JEDEC industry standard classifications, and peak solder temperature.

(4) There may be additional marking, which relates to the logo, the lot trace code information, or the environmental category on the device.

(5) Multiple Device Markings will be inside parentheses. Only one Device Marking contained in parentheses and separated by a "~" will appear on a device. If a line is indented then it is a continuation of the previous line and the two combined represent the entire Device Marking for that device.

(6) Lead finish/Ball material - Orderable Devices may have multiple material finish options. Finish options are separated by a vertical ruled line. Lead finish/Ball material values may wrap to two lines if the finish value exceeds the maximum column width.

Important Information and Disclaimer:The information provided on this page represents TI's knowledge and belief as of the date that it is provided. TI bases its knowledge and belief on information provided by third parties, and makes no representation or warranty as to the accuracy of such information. Efforts are underway to better integrate information from third parties. TI has taken and continues to take reasonable steps to provide representative and accurate information but may not have conducted destructive testing or chemical analysis on incoming materials and chemicals. TI and TI suppliers consider certain information to be proprietary, and thus CAS numbers and other limited information may not be available for release.

In no event shall TI's liability arising out of such information exceed the total purchase price of the TI part(s) at issue in this document sold by TI to Customer on an annual basis.

TAPE AND REEL INFORMATION

QUADRANT ASSIGNMENTS FOR PIN 1 ORIENTATION IN TAPE



*All dimensions are nominal

Device	Package Type	Package Drawing	Pins	SPQ	Reel Diameter (mm)	Reel Width W1 (mm)	A0 (mm)	B0 (mm)	K0 (mm)	P1 (mm)	W (mm)	Pin1 Quadrant
TPS92511DDAR	SO PowerPAD	DDA	8	2500	330.0	12.4	6.5	5.4	2.0	8.0	12.0	Q1

TAPE AND REEL BOX DIMENSIONS

*All dimensions are nominal

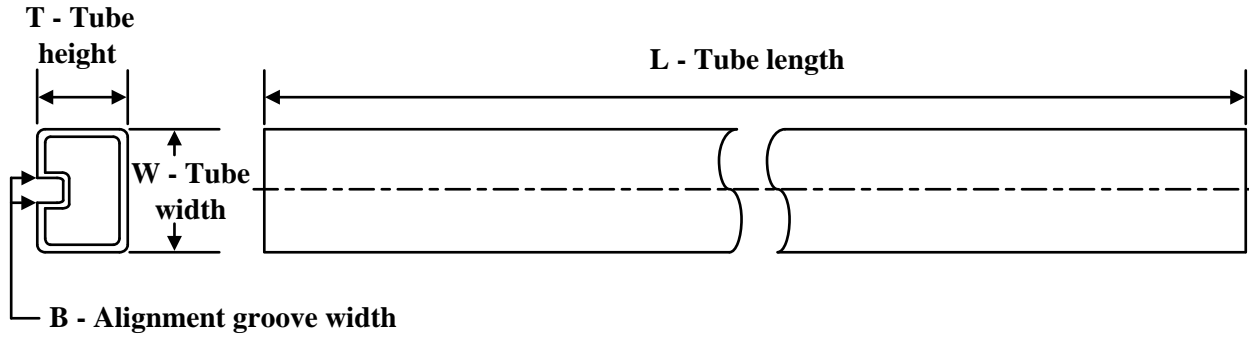
Device	Package Type	Package Drawing	Pins	SPQ	Length (mm)	Width (mm)	Height (mm)
TPS92511DDAR	SO PowerPAD	DDA	8	2500	356.0	356.0	36.0

TUBE

*All dimensions are nominal

Device	Package Name	Package Type	Pins	SPQ	L (mm)	W (mm)	T (μm)	B (mm)
TPS92511DDA	DDA	HSOIC	8	95	495	8	4064	3.05

DDA0008A

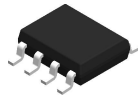

PACKAGE OUTLINE

PowerPAD™ SOIC - 1.7 mm max height

PLASTIC SMALL OUTLINE

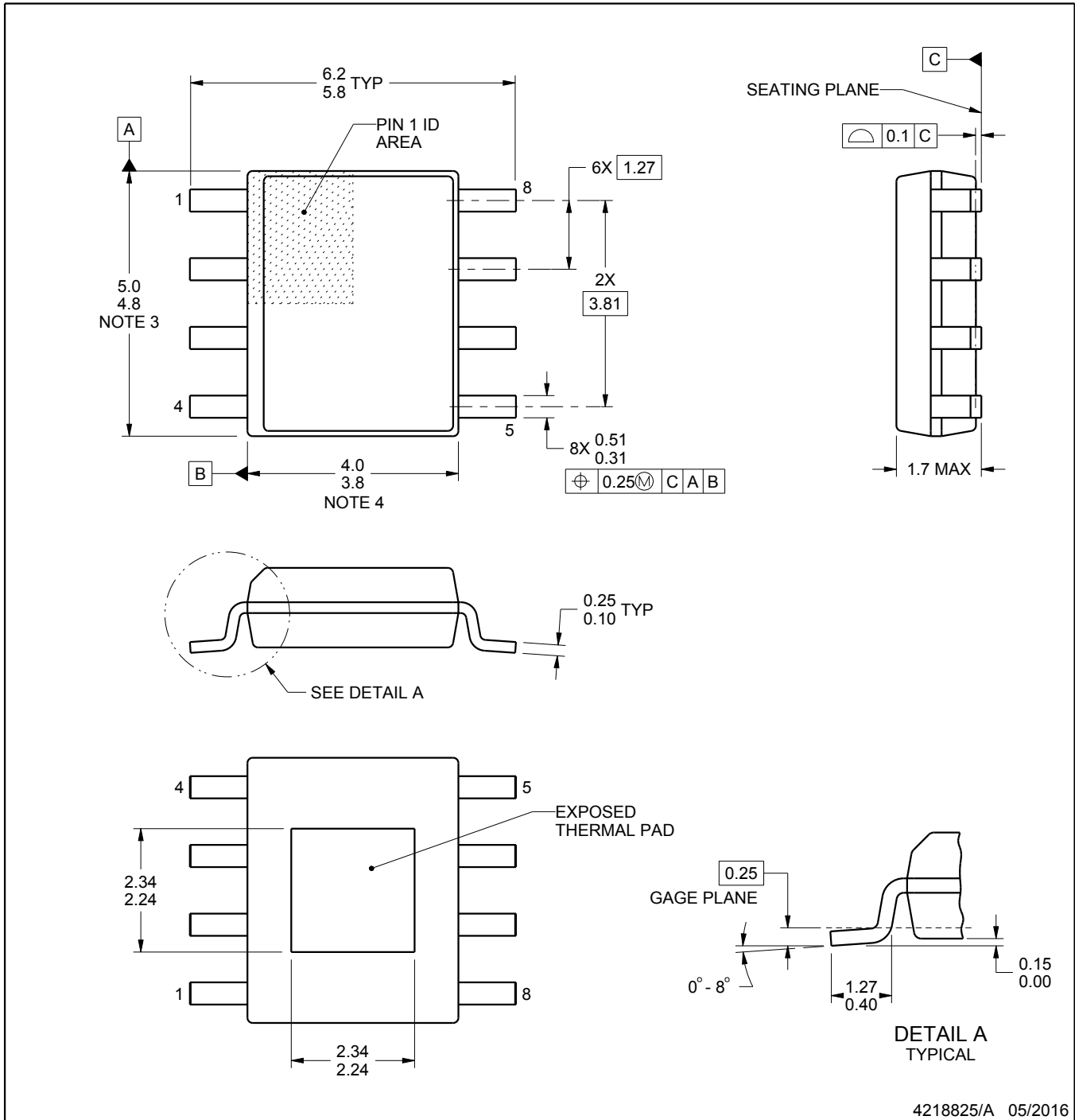

4218825/A 05/2016

PowerPAD is a trademark of Texas Instruments.

NOTES:

1. All linear dimensions are in millimeters. Any dimensions in parenthesis are for reference only. Dimensioning and tolerancing per ASME Y14.5M.
2. This drawing is subject to change without notice.
3. This dimension does not include mold flash, protrusions, or gate burrs. Mold flash, protrusions, or gate burrs shall not exceed 0.15 mm per side.
4. This dimension does not include interlead flash. Interlead flash shall not exceed 0.25 mm per side.
5. Reference JEDEC registration MS-012.

EXAMPLE BOARD LAYOUT

DDA0008A

PowerPAD™ SOIC - 1.7 mm max height

PLASTIC SMALL OUTLINE

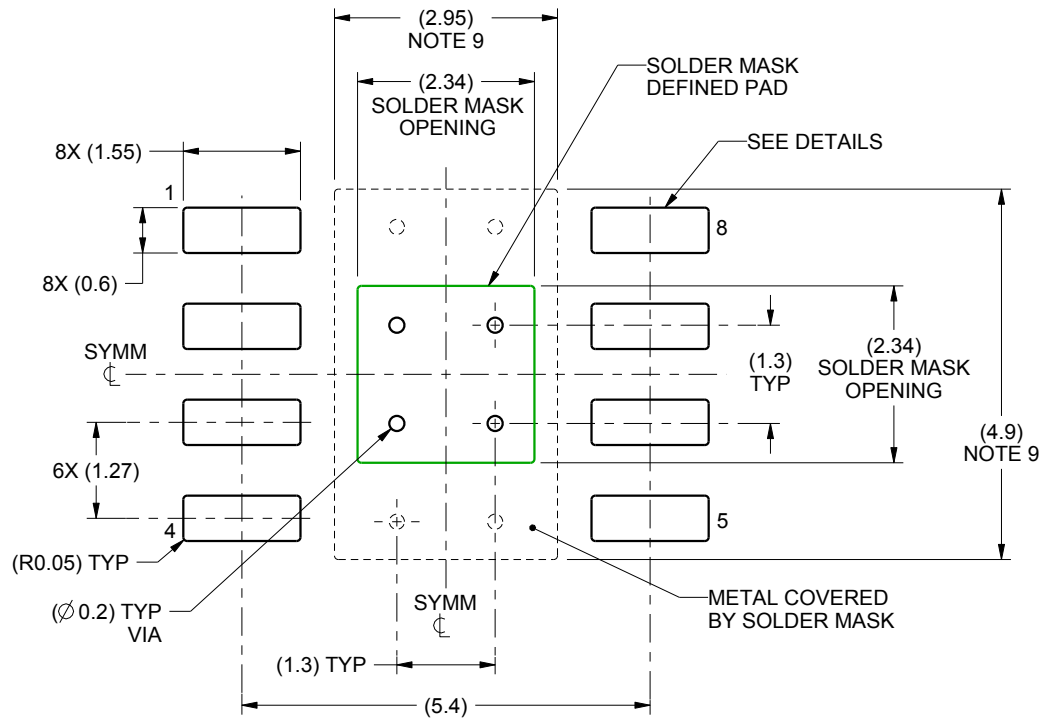

LAND PATTERN EXAMPLE
SCALE:10X

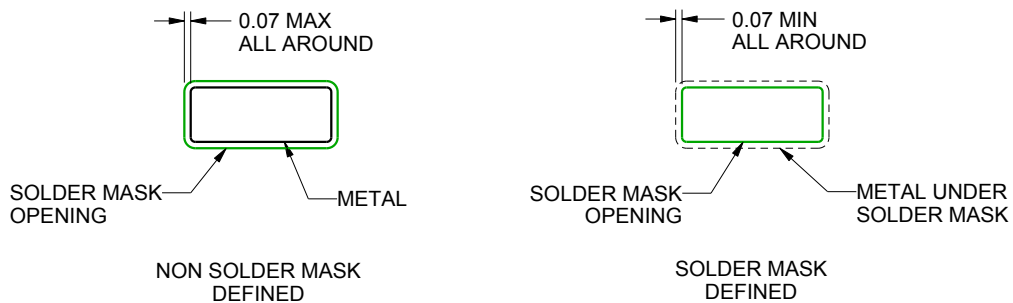

SOLDER MASK DETAILS

4218825/A 05/2016

NOTES: (continued)

6. Publication IPC-7351 may have alternate designs.
7. Solder mask tolerances between and around signal pads can vary based on board fabrication site.
8. This package is designed to be soldered to a thermal pad on the board. For more information, see Texas Instruments literature numbers SLMA002 (www.ti.com/lit/slma002) and SLMA004 (www.ti.com/lit/slma004).
9. Size of metal pad may vary due to creepage requirement.
10. Vias are optional depending on application, refer to device data sheet. If any vias are implemented, refer to their locations shown on this view. It is recommended that vias under paste be filled, plugged or tented.

EXAMPLE STENCIL DESIGN

DDA0008A

PowerPAD™ SOIC - 1.7 mm max height

PLASTIC SMALL OUTLINE

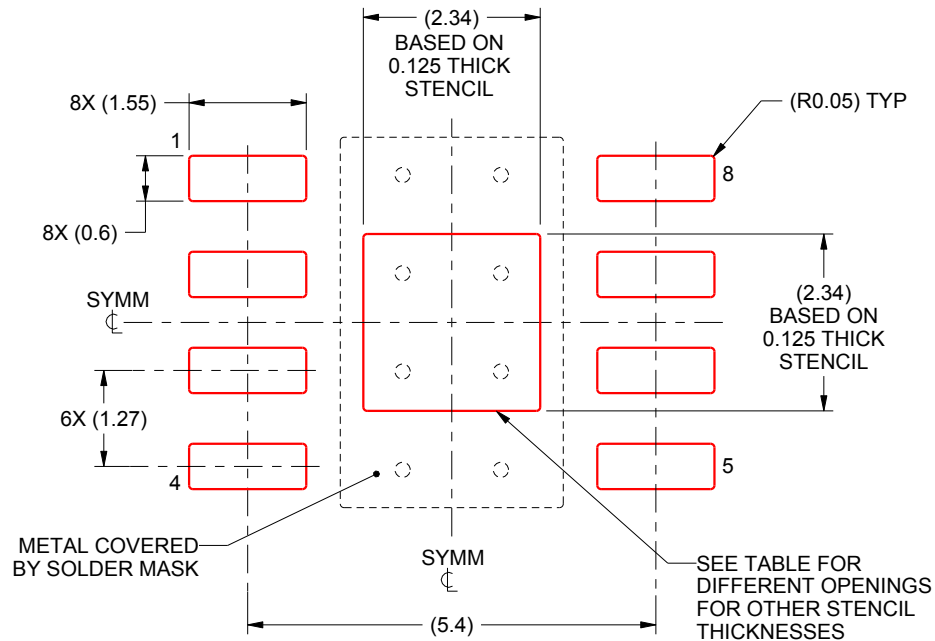

SOLDER PASTE EXAMPLE
 EXPOSED PAD
 100% PRINTED SOLDER COVERAGE BY AREA
 SCALE:10X

STENCIL THICKNESS	SOLDER STENCIL OPENING
0.1	2.62 X 2.62
0.125	2.34 X 2.34 (SHOWN)
0.150	2.14 X 2.14
0.175	1.98 X 1.98

4218825/A 05/2016

NOTES: (continued)

11. Laser cutting apertures with trapezoidal walls and rounded corners may offer better paste release. IPC-7525 may have alternate design recommendations.
12. Board assembly site may have different recommendations for stencil design.

IMPORTANT NOTICE AND DISCLAIMER

TI PROVIDES TECHNICAL AND RELIABILITY DATA (INCLUDING DATA SHEETS), DESIGN RESOURCES (INCLUDING REFERENCE DESIGNS), APPLICATION OR OTHER DESIGN ADVICE, WEB TOOLS, SAFETY INFORMATION, AND OTHER RESOURCES "AS IS" AND WITH ALL FAULTS, AND DISCLAIMS ALL WARRANTIES, EXPRESS AND IMPLIED, INCLUDING WITHOUT LIMITATION ANY IMPLIED WARRANTIES OF MERCHANTABILITY, FITNESS FOR A PARTICULAR PURPOSE OR NON-INFRINGEMENT OF THIRD PARTY INTELLECTUAL PROPERTY RIGHTS.

These resources are intended for skilled developers designing with TI products. You are solely responsible for (1) selecting the appropriate TI products for your application, (2) designing, validating and testing your application, and (3) ensuring your application meets applicable standards, and any other safety, security, regulatory or other requirements.

These resources are subject to change without notice. TI grants you permission to use these resources only for development of an application that uses the TI products described in the resource. Other reproduction and display of these resources is prohibited. No license is granted to any other TI intellectual property right or to any third party intellectual property right. TI disclaims responsibility for, and you will fully indemnify TI and its representatives against, any claims, damages, costs, losses, and liabilities arising out of your use of these resources.

TI's products are provided subject to [TI's Terms of Sale](#) or other applicable terms available either on [ti.com](https://www.ti.com) or provided in conjunction with such TI products. TI's provision of these resources does not expand or otherwise alter TI's applicable warranties or warranty disclaimers for TI products.

TI objects to and rejects any additional or different terms you may have proposed.

Mailing Address: Texas Instruments, Post Office Box 655303, Dallas, Texas 75265
Copyright © 2024, Texas Instruments Incorporated

Looking for pricing, stock, or lifecycle information?

Click below to explore more details on WIN SOURCE:

 [View XC4VLX100-11FFG1148I on WIN SOURCE](#)

 [Xilinx Inc. Information](#)

Optimize Your Supply Chain with WIN SOURCE Solutions

-  Global Sourcing Solution
-  Obsolete Management
-  Cost Control Management
-  Shortage Management
-  Alternative Solution
-  Excess Inventory Management