



**THE DATASHEET OF
VSC8488XJU**



VSC8488 and VSC8484

Multichannel 10 Gbps XAUI to Serial Transceivers with EDC

Microsemi's multichannel 10 GbE transceivers capture the highest port density at the lowest cost.

Microsemi's dual channel and quad channel XAUI-to-serial transceivers, VSC8488 and VSC8484, deliver minimum cost per channel with maximum port densities at the lowest power. The devices achieve an excellent 1 W per channel power dissipation while supporting the increased port densities required for next-generation 10 Gbps platforms.

The VSC8488 and VSC8484 integrate Microsemi's world-class electronic dispersion compensation (EDC) performance across multiple data rates: 9.95 Gbps WAN, 10.3 Gbps Ethernet (GbE), and 10.5 Gbps Fibre Channel. The devices also meet the SFP+ SR/LR/LRM host requirements in accordance with the SFF-8431 and IEEE 802.3aq specifications.

The EDC capabilities are optimized by the VScope™ input signal monitoring integrated circuit, which delivers more accurate, in-line views of the post-equalization waveform.

The VSC8488 and VSC8484 compensate for optical impairments in SFP+ LRM applications, along with degradations of the PCB, while providing wide system margin for SR and LR applications. The transmit path incorporates a multi-tap output driver to provide the flexibility required to meet the demanding 10GBASE-KR (IEEE 802.3ap) standard.

A complete suite of BIST functionality includes line and client loopbacks along with pattern generation and error detection. Highly flexible clocking options support either LAN or WAN operation, along with seamless Synchronous Ethernet. Both devices include selectable lane ordering; the VSC8484 includes failover switching capability for protection routing.

The VSC8488 device supports three serial interface configurations: MDIO, two-wire serial slave, and two-wire serial master. This highly flexible communication scheme, along with a minimum of 12 programmable GPIO pins, allows for independent control of the VSC8488 and VSC8484 channels while providing access to a wide range of device monitors and XFP/SFP+ module management.

Highlights

- Minimum cost per channel

Applications

- Multiple-port XAUI to SFI SFP+ line cards or NICs
- 10GBASE-KR-compliant backplane transceivers
- Synchronous Ethernet systems
- 10 GbE switch cards, router cards, and NICs

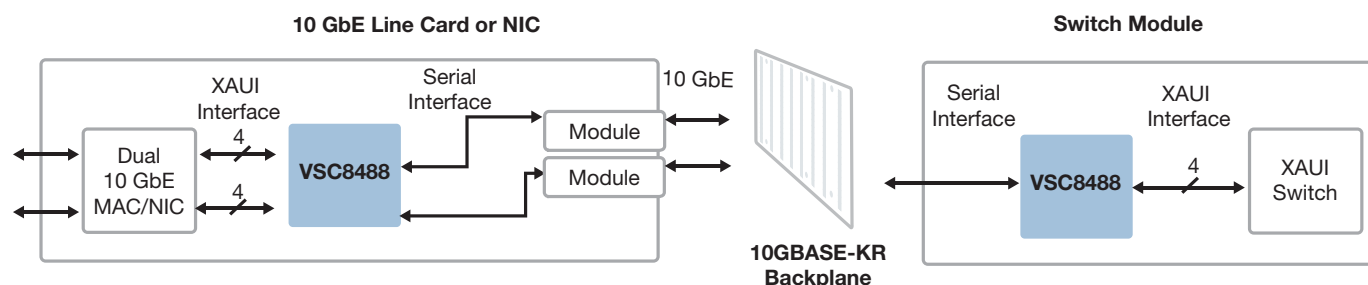

Microsemi makes no warranty, representation, or guarantee regarding the information contained herein or the suitability of its products and services for any particular purpose, nor does Microsemi assume any liability whatsoever arising out of the application or use of any product or circuit. The products sold hereunder and any other products sold by Microsemi have been subject to limited testing and should not be used in conjunction with mission-critical equipment or applications. Any performance specifications are believed to be reliable but are not verified, and Buyer must conduct and complete all performance and other testing of the products, alone and together with, or installed in, any end-products. Buyer shall not rely on any data and performance specifications or parameters provided by Microsemi. It is the Buyer's responsibility to independently determine suitability of any products and to test and verify the same. The information provided by Microsemi hereunder is provided "as is, where is" and with all faults, and the entire risk associated with such information is entirely with the Buyer. Microsemi does not grant, explicitly or implicitly, to any party any patent rights, licenses, or any other IP rights, whether with regard to such information itself or anything described by such information. Information provided in this document is proprietary to Microsemi, and Microsemi reserves the right to make any changes to the information in this document or to any products and services at any time without notice.

VSC8488 and VSC8484

Multichannel 10 Gbps XAUI to Serial Transceivers with EDC

Wide Range of Support

- Compliant with IEEE 802.3aq, IEEE 802.3ae, and SFF-8431 (SFI) electrical specifications
- 9.95 Gbps WAN, 10.3 GbE, and 10.5 Gbps Fibre Channel operation, as well as 1.25 Gbps and 3.125 Gbps legacy support
- Supports SFP+ and XFP SR/LR/LRM applications
- Support for 10GBASE-KR (IEEE 802.3ap) for 10 Gbps backplanes, including 1 Gbps and 10 Gbps autonegotiation
- Adaptive FFE/DFE receiver with programmable, multi-tap transmit pre-emphasis

Key Specifications

- 1 W typical for each bidirectional channel
- 1.8 V and 1.2 V core power supplies (1.2 V to 3.3 VTTL supply)

Flexibility

- Failover switching and lane ordering
- VScope for remote signal monitoring, optimal data eye opening, and lower BER
- Host-side and line-side loopbacks with BIST functions
- I/O programmability for lane swap, invert, amplitude, slew, pre-emphasis, and equalization
- Flexible clocking options enable Layer 1 support for Synchronous Ethernet
- Low power mode
- MDIO, two-wire serial slave, and two-wire serial master interfaces
- Passive copper cable support for minimum transmission cost

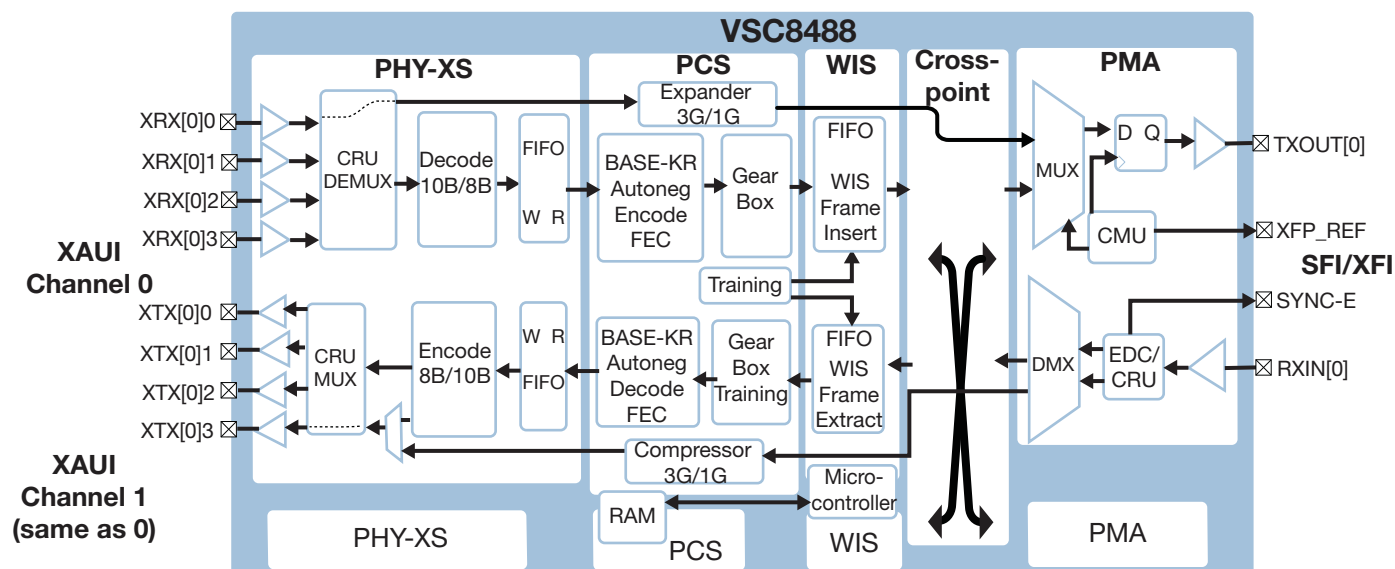

Microsemi

Microsemi Corporate Headquarters
 One Enterprise, Aliso Viejo, CA 92656 USA
 Within the USA: +1 (800) 713-4113
 Outside the USA: +1 (949) 380-6100
 Sales: +1 (949) 380-6136
 Fax: +1 (949) 215-4996
 email: sales.support@microsemi.com
 www.microsemi.com

Microsemi Corporation (Nasdaq: MSCC) offers a comprehensive portfolio of semiconductor and system solutions for communications, defense and security, aerospace, and industrial markets. Products include high-performance and radiation-hardened analog mixed-signal integrated circuits, FPGAs, SoCs, and ASICs; power management products; timing and synchronization devices and precise time solutions; voice processing devices; RF solutions; discrete components; enterprise storage and communications solutions, security technologies, and scalable anti-tamper products; Ethernet solutions; Power-over-Ethernet ICs and midspans; custom design capabilities and services. Microsemi is headquartered in Aliso Viejo, California, and has approximately 4,800 employees worldwide. Learn more at www.microsemi.com.

Looking for pricing, stock, or lifecycle information?

Click below to explore more details on WIN SOURCE:

- ⊖ [View VSC8488XJU on WIN SOURCE](#)
- ⊖ [Microchip Technology Information](#)

Optimize Your Supply Chain with WIN SOURCE Solutions

- ✓ Global Sourcing Solution
- ✓ Obsolete Management
- ✓ Cost Control Management
- ✓ Shortage Management
- ✓ Alternative Solution
- ✓ Excess Inventory Management