



# THE DATASHEET OF VN820





# VN820 / VN820SO VN820SP / VN820-B5 / VN820PT

## HIGH SIDE DRIVER

| TYPE     | $R_{DS(on)}$ | $I_{OUT}$ | $V_{CC}$ |
|----------|--------------|-----------|----------|
| VN820    | 40 mΩ        | 9 A       | 36 V     |
| VN820SP  |              |           |          |
| VN820-B5 |              |           |          |
| VN820SO  |              |           |          |
| VN820PT  |              |           |          |

- CMOS COMPATIBLE INPUT
- ON STATE OPEN LOAD DETECTION
- OFF STATE OPEN LOAD DETECTION
- SHORTED LOAD PROTECTION
- UNDERVOLTAGE AND OVERVOLTAGE SHUTDOWN
- PROTECTION AGAINST LOSS OF GROUND
- VERY LOW STAND-BY CURRENT
- REVERSE BATTERY PROTECTION (\*)

### DESCRIPTION

The VN820, VN820SP, VN820-B5, VN820SO, VN820PT are monolithic devices made by using STMicroelectronics VIPower M0-3 Technology, intended for driving any kind of load with one side connected to ground.

Active  $V_{CC}$  pin voltage clamp protects the device against low energy spikes (see ISO7637 transient

### BLOCK DIAGRAM

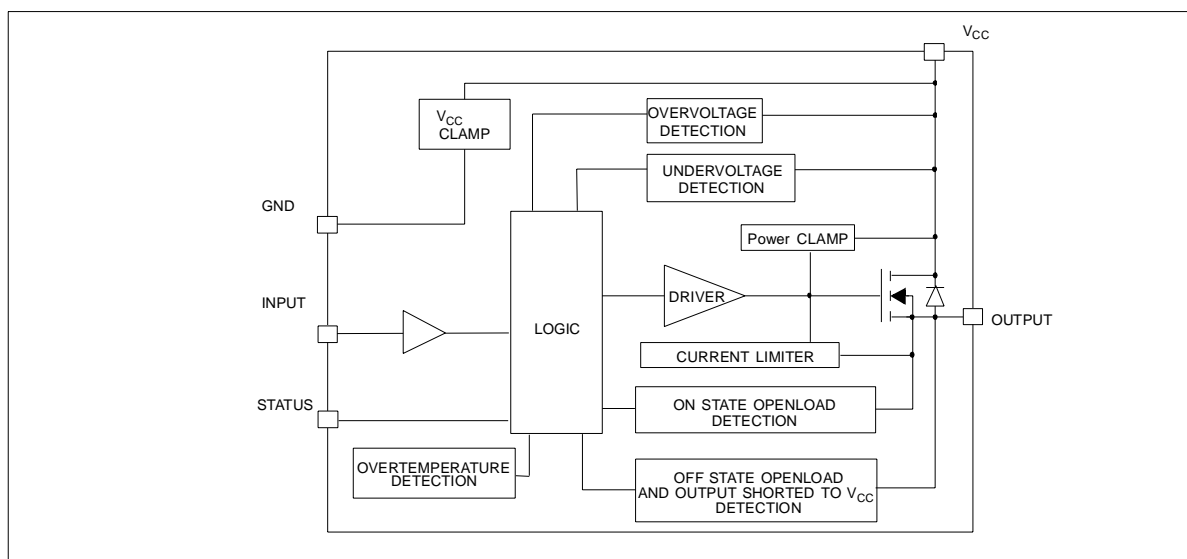

(\*) See application schematic at page 9  
June 2003

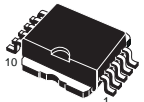

**PowerSO-10™**

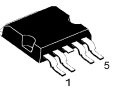

**P<sup>2</sup>PAK**

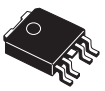

**PPAK**

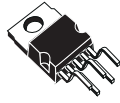

**PENTAWATT**

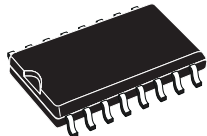

**SO-16L**

| ORDER CODES        |          |              |
|--------------------|----------|--------------|
| PACKAGE            | TUBE     | T&R          |
| PENTAWATT          | VN820    | -            |
| PowerSO-10™        | VN820SP  | VN820SP13TR  |
| P <sup>2</sup> PAK | VN820-B5 | VN820-B513TR |
| SO-16L             | VN820SO  | VN820SO13TR  |
| PPAK               | VN820PT  | VN820PT13TR  |

compatibility table). Active current limitation combined with thermal shutdown and automatic restart protect the device against overload.

The device detects open load condition both is on and off state. Output shorted to  $V_{CC}$  is detected in the off state. Device automatically turns off in case of ground pin disconnection.

VN820 / VN820SO / VN820SP / VN820-B5 / VN820PT

**ABSOLUTE MAXIMUM RATING**

| Symbol             | Parameter   | Value              |           |                    |        |      | Unit |
|--------------------|---|--------------------|-----------|--------------------|--------|------|------|
|                    |   | PowerSO-10™        | PENTAWATT | P <sup>2</sup> PAK | SO-16L | PPAK |      |
| V <sub>CC</sub>    | DC Supply Voltage   | 41                 |           |                    |        |      | V    |
| - V <sub>CC</sub>  | Reverse DC Supply Voltage   | - 0.3              |           |                    |        |      | V    |
| - I <sub>GND</sub> | DC Reverse Ground Pin Current   | - 200              |           |                    |        |      | mA   |
| I <sub>OUT</sub>   | DC Output Current   | Internally Limited |           |                    |        |      | A    |
| - I <sub>OUT</sub> | Reverse DC Output Current   | - 9                |           |                    |        |      | A    |
| I <sub>IN</sub>    | DC Input Current  | +/- 10             |           |                    |        |      | mA   |
| I <sub>STAT</sub>  | DC Status Current   | +/- 10             |           |                    |        |      | mA   |
| V <sub>ESD</sub>   | Electrostatic Discharge<br>(Human Body Model: R=1.5KΩ; C=100pF)   |                    |           |                    |        |      |      |
|                    | - INPUT   | 4000               |           |                    |        |      | V    |
|                    | - STATUS  | 4000               |           |                    |        |      | V    |
|                    | - OUTPUT  | 5000               |           |                    |        |      | V    |
|                    | - V <sub>CC</sub>   | 5000               |           |                    |        |      | V    |
| E <sub>MAX</sub>   | Maximum Switching Energy (L=4mH; R <sub>L</sub> =0Ω; V <sub>bat</sub> =13.5V; T <sub>jstart</sub> =150°C; I <sub>L</sub> =13A)    | 481                |           | 481                |        |      | mJ   |
| E <sub>MAX</sub>   | Maximum Switching Energy (L=3.7mH; R <sub>L</sub> =0Ω; V <sub>bat</sub> =13.5V; T <sub>jstart</sub> =150°C; I <sub>L</sub> =13A)  |                    |           |                    | 438    |      | mJ   |
| E <sub>MAX</sub>   | Maximum Switching Energy (L=4.48mH; R <sub>L</sub> =0Ω; V <sub>bat</sub> =13.5V; T <sub>jstart</sub> =150°C; I <sub>L</sub> =13A) |                    |           |                    |        | 526  | mJ   |
| P <sub>tot</sub>   | Power Dissipation T <sub>C</sub> =25°C  | 65.8               | 65.8      | 65.8               | 8.3    | 65.8 | W    |
| T <sub>j</sub>     | Junction Operating Temperature  | Internally Limited |           |                    |        |      | °C   |
| T <sub>C</sub>     | Case Operating Temperature  | - 40 to 150        |           |                    |        |      | °C   |
| T <sub>stg</sub>   | Storage Temperature   | - 55 to 150        |           |                    |        |      | °C   |

**CONNECTION DIAGRAM (TOP VIEW)**

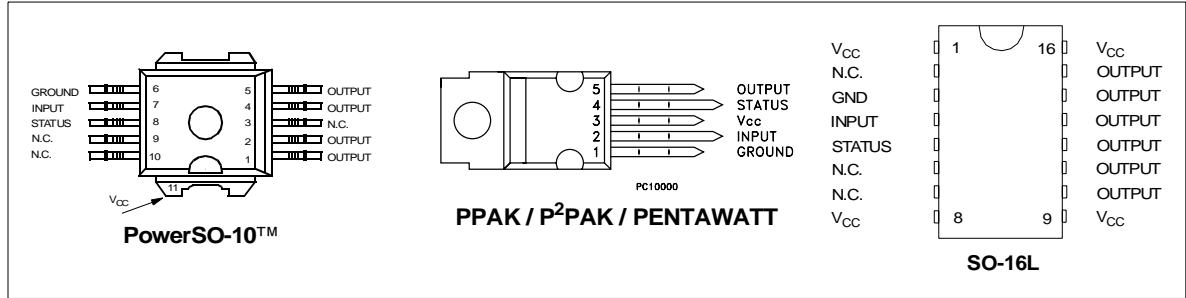

**CURRENT AND VOLTAGE CONVENTIONS**

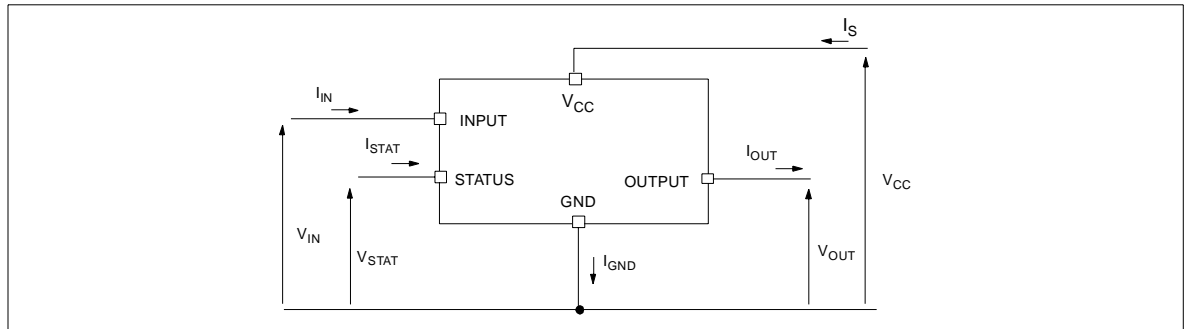

**THERMAL DATA**

| Symbol                | Parameter                               | Value       |           |                    |         |          | Unit |
|-----------------------|---|-------------|-----------|--------------------|---------|----------|------|
|                       |   | PowerSO-10™ | PENTAWATT | P <sup>2</sup> PAK | SO-16L  | PPAK     |      |
| R <sub>thj-case</sub> | Thermal Resistance Junction-case Max    | 1.9         | 1.9       | 1.9                | -       | 1.9      | °C/W |
| R <sub>thj-lead</sub> | Thermal Resistance Junction-lead Max    | -           | -         | -                  | 15      | -        | °C/W |
| R <sub>thj-amb</sub>  | Thermal Resistance Junction-ambient Max | 51.9 (*)    | 61.9 (*)  | 51.9 (*)           | 65 (**) | 76.9 (*) | °C/W |

(\*) When mounted on a standard single-sided FR-4 board with 0.5cm<sup>2</sup> of Cu (at least 35µm thick).

(\*\*) When mounted on FR4 printed circuit board with 0.5cm<sup>2</sup> of Cu (at least 35µ thick) connected to all V<sub>CC</sub> pins.

**ELECTRICAL CHARACTERISTICS** (8V < V<sub>CC</sub> < 36V; -40°C < T<sub>j</sub> < 150°C unless otherwise specified)

**POWER**

| Symbol               | Parameter                         | Test Conditions  | Min | Typ           | Max             | Unit           |
|----------------------|-----------------------------------|--|-----|---------------|-----------------|----------------|
| V <sub>CC</sub>      | Operating Supply Voltage          |  | 5.5 | 13            | 36              | V              |
| V <sub>USD</sub>     | Undervoltage Shut-down            |  | 3   | 4             | 5.5             | V              |
| V <sub>USDhyst</sub> | Undervoltage Shut-down hysteresis |  |     | 0.5           |                 | V              |
| V <sub>OV</sub>      | Overvoltage Shut-down             |  | 36  |               |                 | V              |
| R <sub>ON</sub>      | On State Resistance               | I <sub>OUT</sub> =3A; T <sub>j</sub> =25°C; V <sub>CC</sub> >8V<br>I <sub>OUT</sub> =3A; V <sub>CC</sub> >8V   |     |               | 40<br>80        | mΩ<br>mΩ       |
| I <sub>S</sub>       | Supply Current                    | Off State; V <sub>CC</sub> =13V; V <sub>IN</sub> =V <sub>OUT</sub> =0V<br>Off State; V <sub>CC</sub> =13V; V <sub>IN</sub> =V <sub>OUT</sub> =0V;<br>T <sub>j</sub> =25°C<br>On State; V <sub>CC</sub> =13V; V <sub>IN</sub> =5V; I <sub>OUT</sub> =0A |     | 10<br>10<br>2 | 25<br>20<br>3.5 | µA<br>µA<br>mA |
| I <sub>L(off1)</sub> | Off State Output Current          | V <sub>IN</sub> =V <sub>OUT</sub> =0V  | 0   |               | 50              | µA             |
| I <sub>L(off2)</sub> | Off State Output Current          | V <sub>IN</sub> =0V; V <sub>OUT</sub> =3.5V  | -75 |               | 0               | µA             |
| I <sub>L(off3)</sub> | Off State Output Current          | V <sub>IN</sub> =V <sub>OUT</sub> =0V; V <sub>CC</sub> =13V; T <sub>j</sub> =125°C   |     |               | 5               | µA             |
| I <sub>L(off4)</sub> | Off State Output Current          | V <sub>IN</sub> =V <sub>OUT</sub> =0V; V <sub>CC</sub> =13V; T <sub>j</sub> =25°C  |     |               | 3               | µA             |

**SWITCHING** (V<sub>CC</sub>=13V)

| Symbol                                 | Parameter              | Test Conditions  | Min | Typ                        | Max | Unit |
|--|------------------------|--|-----|----------------------------|-----|------|
| t <sub>d(on)</sub>                     | Turn-on Delay Time     | R <sub>L</sub> =4.3Ω from V <sub>IN</sub> rising edge to<br>V <sub>OUT</sub> =1.3V   |     | 30                         |     | µs   |
| t <sub>d(off)</sub>                    | Turn-off Delay Time    | R <sub>L</sub> =4.3Ω from V <sub>IN</sub> falling edge to<br>V <sub>OUT</sub> =11.7V |     | 30                         |     | µs   |
| dV <sub>OUT</sub> /dt <sub>(on)</sub>  | Turn-on Voltage Slope  | R <sub>L</sub> =4.3Ω from V <sub>OUT</sub> =1.3 to<br>V <sub>OUT</sub> =10.4V        |     | See<br>relative<br>diagram |     | V/µs |
| dV <sub>OUT</sub> /dt <sub>(off)</sub> | Turn-off Voltage Slope | R <sub>L</sub> =4.3Ω from V <sub>OUT</sub> =11.7 to<br>V <sub>OUT</sub> =1.3V        |     | See<br>relative<br>diagram |     | V/µs |

**INPUT PIN**

| Symbol               | Parameter                | Test Conditions                               | Min  | Typ         | Max  | Unit   |
|----------------------|--------------------------|---|------|-------------|------|--------|
| V <sub>IL</sub>      | Input Low Level          |   |      |             | 1.25 | V      |
| I <sub>IL</sub>      | Low Level Input Current  | V <sub>IN</sub> =1.25V                        | 1    |             |      | µA     |
| V <sub>IH</sub>      | Input High Level         |   | 3.25 |             |      | V      |
| I <sub>IH</sub>      | High Level Input Current | V <sub>IN</sub> =3.25V                        |      |             | 10   | µA     |
| V <sub>I(hyst)</sub> | Input Hysteresis Voltage |   | 0.5  |             |      | V      |
| V <sub>ICL</sub>     | Input Clamp Voltage      | I <sub>IN</sub> =1mA<br>I <sub>IN</sub> =-1mA | 6    | 6.8<br>-0.7 | 8    | V<br>V |

**ELECTRICAL CHARACTERISTICS** (continued)

STATUS PIN

| Symbol      | Parameter                    | Test Conditions                | Min | Typ  | Max | Unit    |
|-------------|------------------------------|--------------------------------|-----|------|-----|---------|
| $V_{STAT}$  | Status Low Output Voltage    | $I_{STAT}=1.6mA$               |     |      | 0.5 | V       |
| $I_{LSTAT}$ | Status Leakage Current       | Normal Operation $V_{STAT}=5V$ |     |      | 10  | $\mu A$ |
| $C_{STAT}$  | Status Pin Input Capacitance | Normal Operation $V_{STAT}=5V$ |     |      | 100 | pF      |
| $V_{SCL}$   | Status Clamp Voltage         | $I_{STAT}=1mA$                 | 6   | 6.8  | 8   | V       |
|             |                              | $I_{STAT}=-1mA$                |     | -0.7 |     | V       |

PROTECTIONS

| Symbol      | Parameter                          | Test Conditions                | Min         | Typ         | Max         | Unit        |
|-------------|------------------------------------|--------------------------------|-------------|-------------|-------------|-------------|
| $T_{TSD}$   | Shut-down Temperature              |                                | 150         | 175         | 200         | $^{\circ}C$ |
| $T_R$       | Reset Temperature                  |                                | 135         |             |             | $^{\circ}C$ |
| $T_{hyst}$  | Thermal Hysteresis                 |                                | 7           | 15          |             | $^{\circ}C$ |
| $t_{SDL}$   | Status delay in overload condition | $T_j > T_{TSD}$                |             |             | 20          | $\mu s$     |
| $I_{lim}$   | Current limitation                 | $5.5V < V_{CC} < 36V$          | 9           | 13          | 20          | A           |
| $V_{demag}$ | Turn-off Output Clamp Voltage      | $I_{OUT}=3A; V_{IN}=0V; L=6mH$ | $V_{CC}-41$ | $V_{CC}-48$ | $V_{CC}-55$ | V           |

OPENLOAD DETECTION

| Symbol         | Parameter                                      | Test Conditions | Min | Typ | Max  | Unit    |
|----------------|--|-----------------|-----|-----|------|---------|
| $I_{OL}$       | Openload ON State Detection Threshold          | $V_{IN}=5V$     | 70  | 150 | 300  | mA      |
| $t_{DOL(on)}$  | Openload ON State Detection Delay              | $I_{OUT}=0A$    |     |     | 200  | $\mu s$ |
| $V_{OL}$       | Openload OFF State Voltage Detection Threshold | $V_{IN}=0V$     | 1.5 | 2.5 | 3.5  | V       |
| $t_{DOL(off)}$ | Openload Detection Delay at Turn Off           |                 |     |     | 1000 | $\mu s$ |

OPEN LOAD STATUS TIMING (with external pull-up)

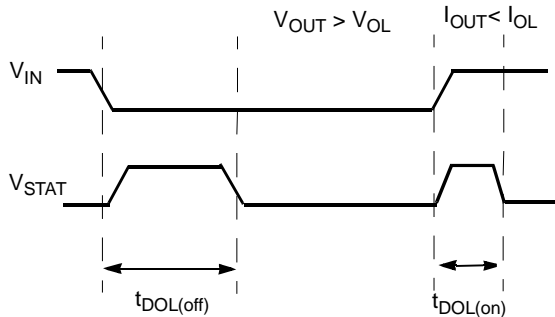

OVERTEMP STATUS TIMING

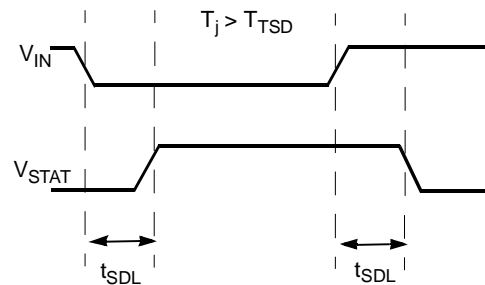

Switching time Waveforms

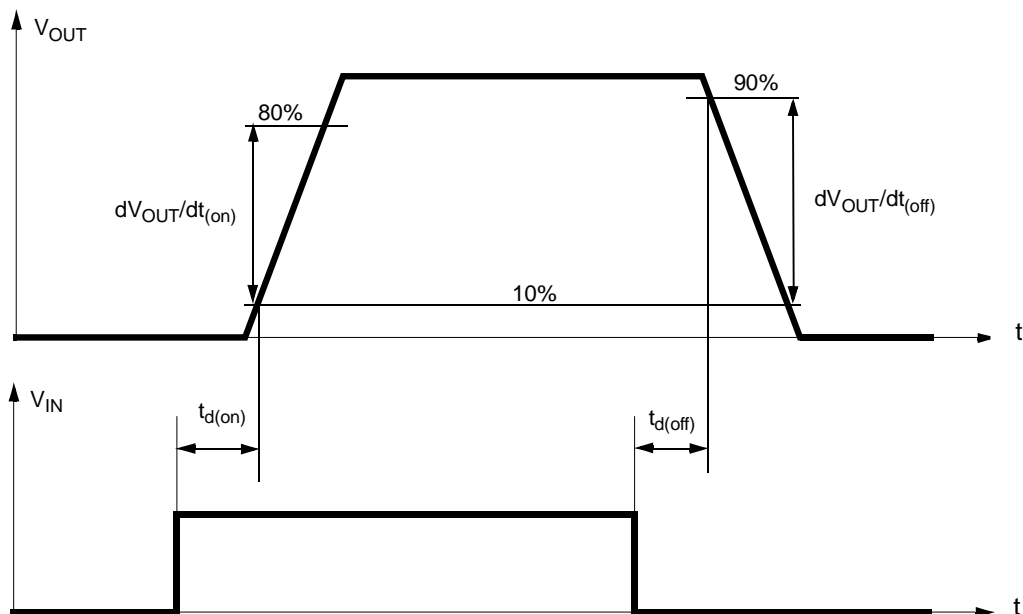

TRUTH TABLE

| CONDITIONS                | INPUT | OUTPUT | STATUS              |
|---------------------------|-------|--------|---------------------|
| Normal Operation          | L     | L      | H                   |
|                           | H     | H      | H                   |
| Current Limitation        | L     | L      | H                   |
|                           | H     | X      | $(T_j < T_{TSD})$ H |
|                           | H     | X      | $(T_j > T_{TSD})$ L |
| Overtemperature           | L     | L      | H                   |
|                           | H     | L      | L                   |
| Undervoltage              | L     | L      | X                   |
|                           | H     | L      | X                   |
| Overvoltage               | L     | L      | H                   |
|                           | H     | L      | H                   |
| Output Voltage $> V_{OL}$ | L     | H      | L                   |
|                           | H     | H      | H                   |
| Output Current $< I_{OL}$ | L     | L      | H                   |
|                           | H     | H      | L                   |

**OPEN LOAD DETECTION IN OFF STATE**

Off state open load detection requires an external pull-up resistor ( $R_{PU}$ ) connected between OUTPUT pin and a positive supply voltage ( $V_{PU}$ ) like the +5V line used to supply the microprocessor.

The external resistor has to be selected according to the following requirements:

- 1) no false open load indication when load is connected: in this case we have to avoid  $V_{OUT}$  to be higher than  $V_{OLmin}$ ; this results in the following condition  $V_{OUT} = (V_{PU} / (R_L + R_{PU})) R_L < V_{OLmin}$ .

- 2) no misdetection when load is disconnected: in this case the  $V_{OUT}$  has to be higher than  $V_{OLmax}$ ; this results in the following condition  $R_{PU} < (V_{PU} - V_{OLmax}) / I_{L(off2)}$ .

Because  $I_{S(OFF)}$  may significantly increase if  $V_{OUT}$  is pulled high (up to several mA), the pull-up resistor  $R_{PU}$  should be connected to a supply that is switched OFF when the module is in standby.

The values of  $V_{OLmin}$ ,  $V_{OLmax}$  and  $I_{L(off2)}$  are available in the Electrical Characteristics section.

**Open Load detection in off state**

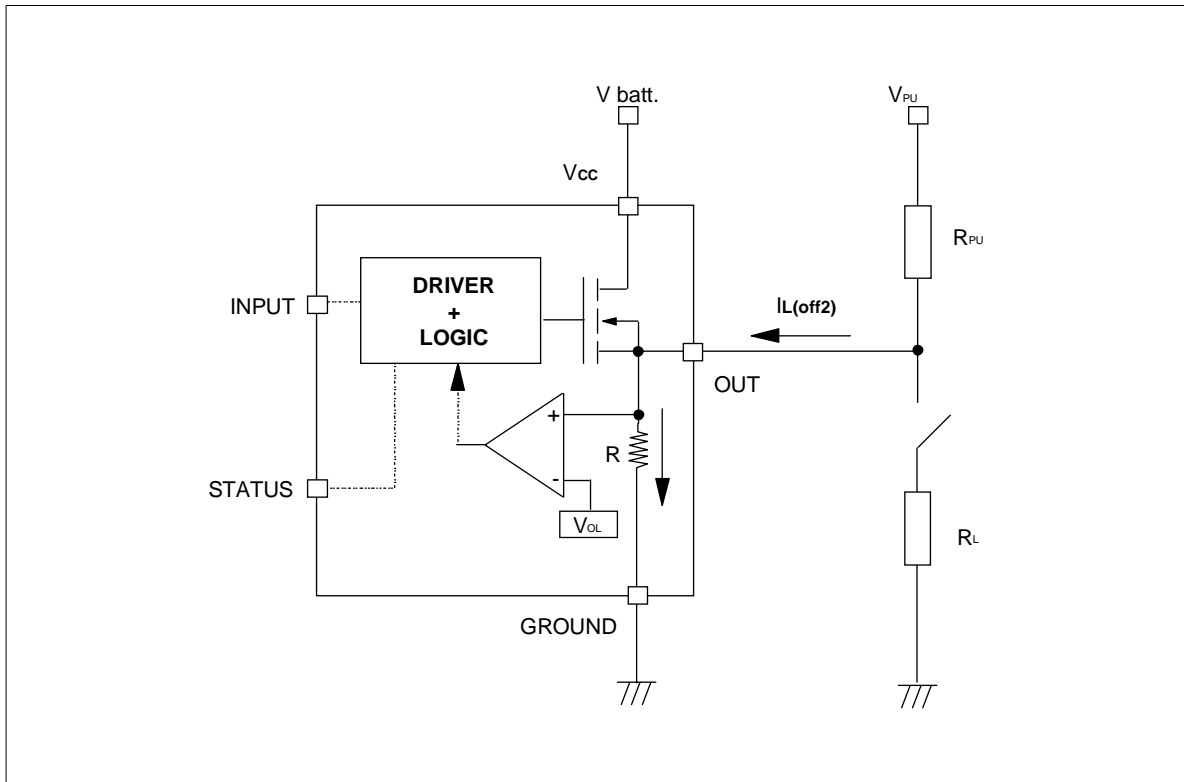

**ELECTRICAL TRANSIENT REQUIREMENTS ON V<sub>CC</sub> PIN**

| ISO T/R 7637/1<br>Test Pulse | TEST LEVELS |         |         |         | Delays and<br>Impedance |
|------------------------------|-------------|---------|---------|---------|-------------------------|
|                              | I           | II      | III     | IV      |                         |
| 1                            | -25 V       | -50 V   | -75 V   | -100 V  | 2 ms 10 Ω               |
| 2                            | +25 V       | +50 V   | +75 V   | +100 V  | 0.2 ms 10 Ω             |
| 3a                           | -25 V       | -50 V   | -100 V  | -150 V  | 0.1 μs 50 Ω             |
| 3b                           | +25 V       | +50 V   | +75 V   | +100 V  | 0.1 μs 50 Ω             |
| 4                            | -4 V        | -5 V    | -6 V    | -7 V    | 100 ms, 0.01 Ω          |
| 5                            | +26.5 V     | +46.5 V | +66.5 V | +86.5 V | 400 ms, 2 Ω             |

| ISO T/R 7637/1<br>Test Pulse | TEST LEVELS RESULTS |    |     |    |
|------------------------------|---------------------|----|-----|----|
|                              | I                   | II | III | IV |
| 1                            | C                   | C  | C   | C  |
| 2                            | C                   | C  | C   | C  |
| 3a                           | C                   | C  | C   | C  |
| 3b                           | C                   | C  | C   | C  |
| 4                            | C                   | C  | C   | C  |
| 5                            | C                   | E  | E   | E  |

| CLASS    | CONTENTS  |
|----------|---|
| <b>C</b> | All functions of the device are performed as designed after exposure to disturbance.  |
| <b>E</b> | One or more functions of the device is not performed as designed after exposure to disturbance and cannot be returned to proper operation without replacing the device. |

Figure 1: Waveforms

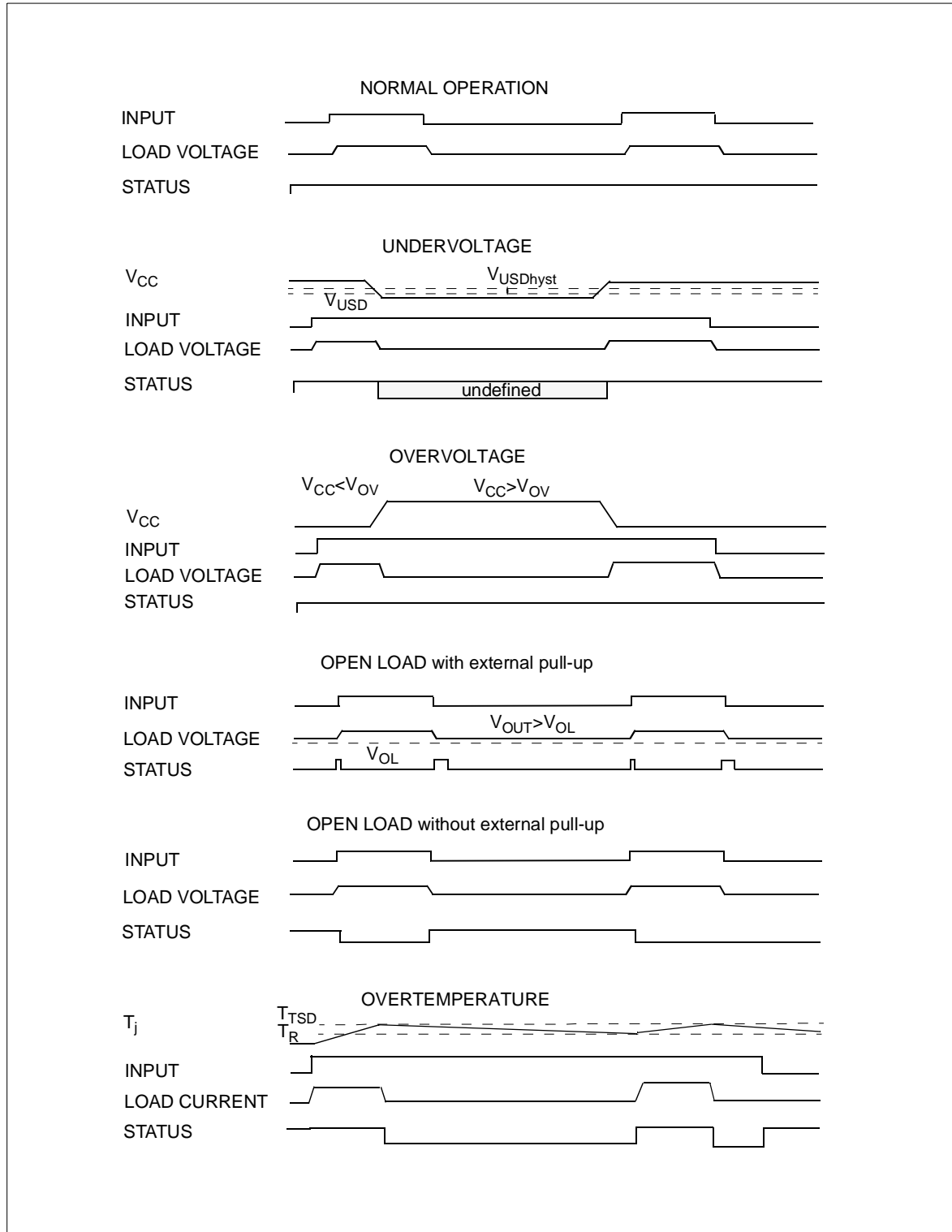

**APPLICATION SCHEMATIC**

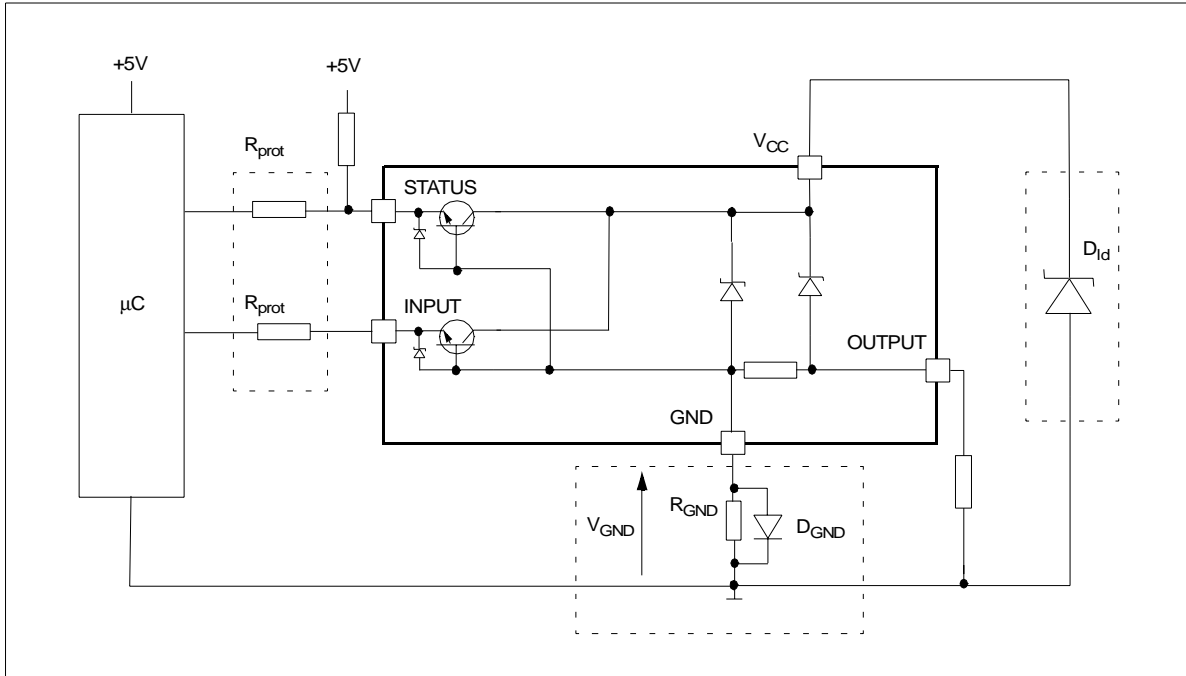

**GND PROTECTION NETWORK AGAINST REVERSE BATTERY**

**Solution 1:** Resistor in the ground line ( $R_{GND}$  only). This can be used with any type of load.

The following is an indication on how to dimension the  $R_{GND}$  resistor.

- 1)  $R_{GND} \leq 600\text{mV} / (I_{S(on)max})$ .
- 2)  $R_{GND} \geq (-V_{CC}) / (-I_{GND})$

where  $-I_{GND}$  is the DC reverse ground pin current and can be found in the absolute maximum rating section of the of the device's datasheet.

Power Dissipation in  $R_{GND}$  (when  $V_{CC} < 0$ : during reverse battery situations) is:

$$P_D = (-V_{CC})^2 / R_{GND}$$

This resistor can be shared amongst several different HSD. Please note that the value of this resistor should be calculated with formula (1) where  $I_{S(on)max}$  becomes the sum of the maximum on-state currents of the different devices.

Please note that if the microprocessor ground is not common with the device ground then the  $R_{GND}$  will produce a shift ( $I_{S(on)max} * R_{GND}$ ) in the input thresholds and the status output values. This shift will vary depending on many devices are ON in the case of several high side drivers sharing the same  $R_{GND}$ .

If the calculated power dissipation leads to a large resistor or several devices have to share the same resistor then the ST suggest to utilize Solution 2 (see below).

**Solution 2:** A diode ( $D_{GND}$ ) in the ground line.

A resistor ( $R_{GND}=1\text{k}\Omega$ ) should be inserted in parallel to  $D_{GND}$  if the device will be driving an inductive load.

This small signal diode can be safely shared amongst several different HSD. Also in this case, the presence of the ground network will produce a shift ( $\approx 600\text{mV}$ ) in the input threshold and the status output values if the microprocessor ground is not common with the device ground. This shift will not vary if more than one HSD shares the same diode/resistor network.

**LOAD DUMP PROTECTION**

$D_{Id}$  is necessary (Voltage Transient Suppressor) if the load dump peak voltage exceeds  $V_{CC}$  max DC rating. The same applies if the device will be subject to transients on the  $V_{CC}$  line that are greater than the ones shown in the ISO T/R 7637/1 table.

**µC I/Os PROTECTION:**

If a ground protection network is used and negative transient are present on the  $V_{CC}$  line, the control pins will be pulled negative. ST suggests to insert a resistor ( $R_{prot}$ ) in line to prevent the  $\mu\text{C}$  I/Os pins to latch-up.

The value of these resistors is a compromise between the leakage current of  $\mu\text{C}$  and the current required by the HSD I/Os (Input levels compatibility) with the latch-up limit of  $\mu\text{C}$  I/Os.

$$-V_{CCpeak} / I_{latchup} \leq R_{prot} \leq (V_{OH\mu C} - V_{IH} - V_{GND}) / I_{IHmax}$$

Calculation example:

For  $V_{CCpeak} = -100\text{V}$  and  $I_{latchup} \geq 20\text{mA}$ ;  $V_{OH\mu C} \geq 4.5\text{V}$

$$5\text{k}\Omega \leq R_{prot} \leq 65\text{k}\Omega$$

Recommended  $R_{prot}$  value is  $10\text{k}\Omega$ .

Off State Output Current

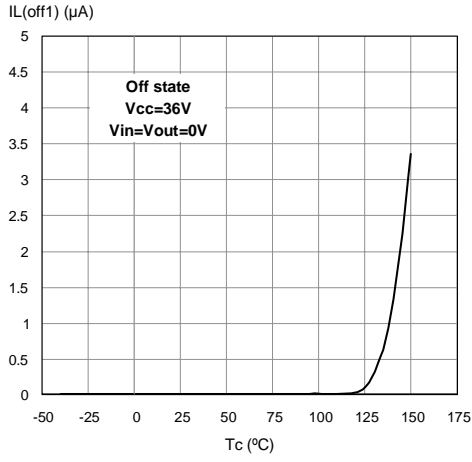

High Level Input Current

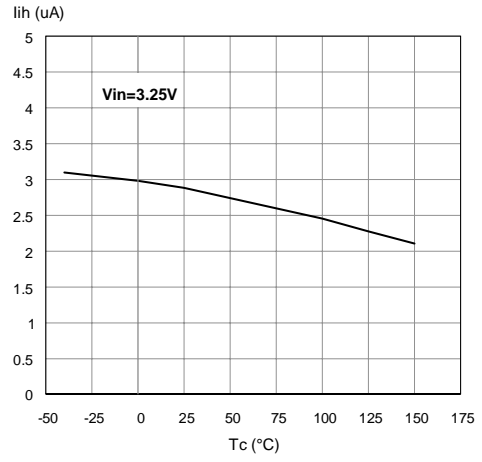

Input Clamp Voltage

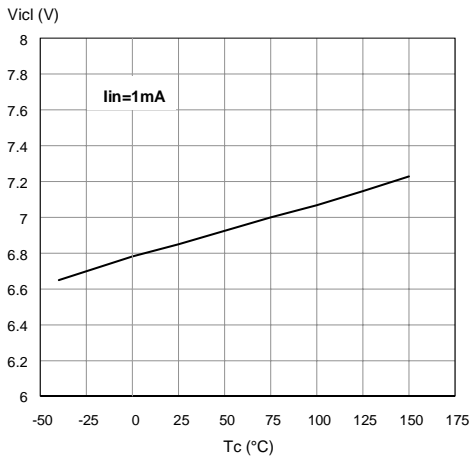

Input High Level

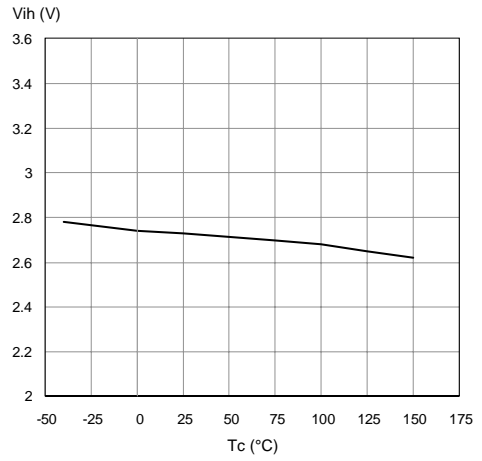

Input Low Level

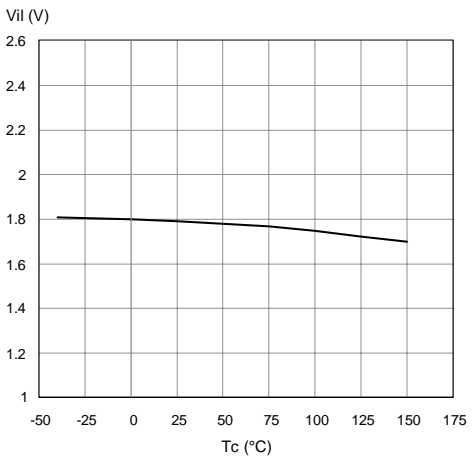

Input Hysteresis Voltage

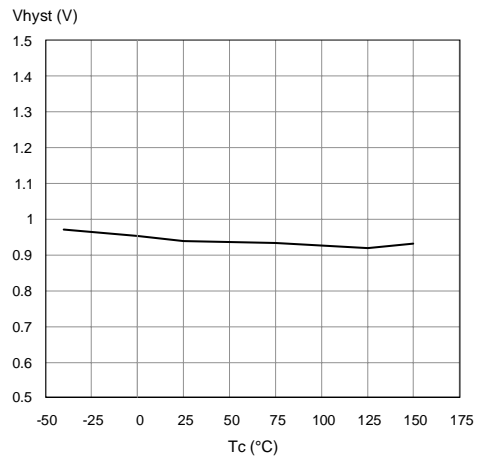

Overvoltage Shutdown

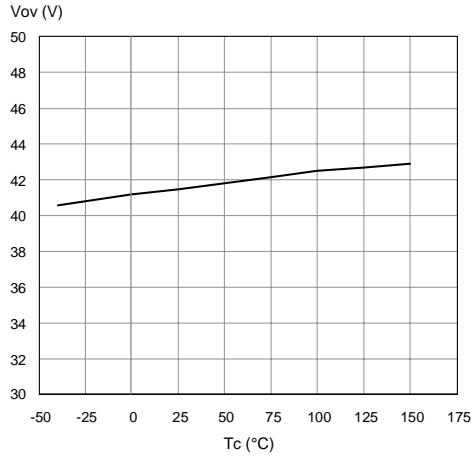

I<sub>LIM</sub> Vs T<sub>case</sub>

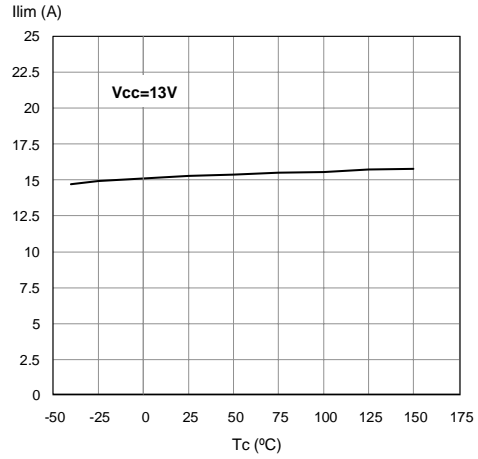

Turn-on Voltage Slope

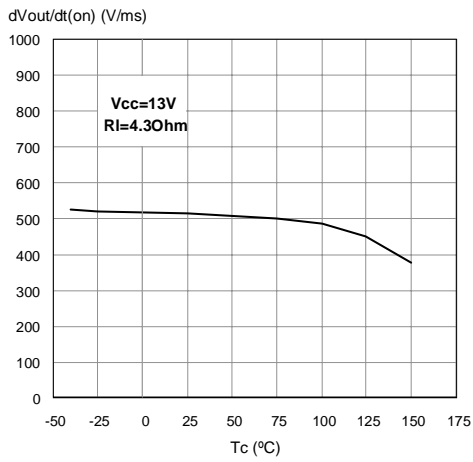

Turn-off Voltage Slope

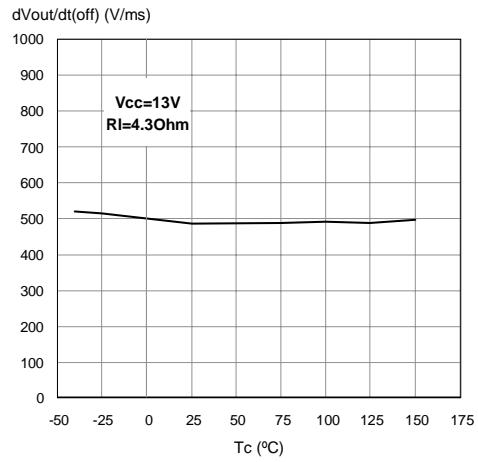

On State Resistance Vs T<sub>case</sub>

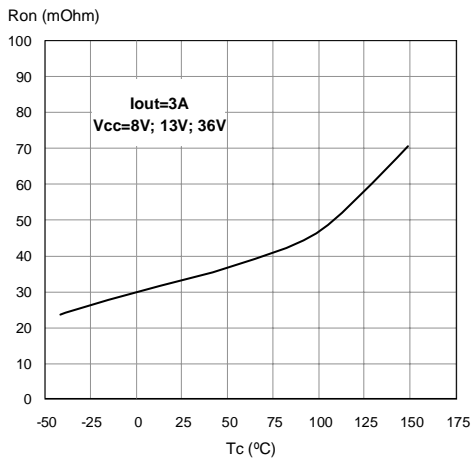

On State Resistance Vs V<sub>CC</sub>

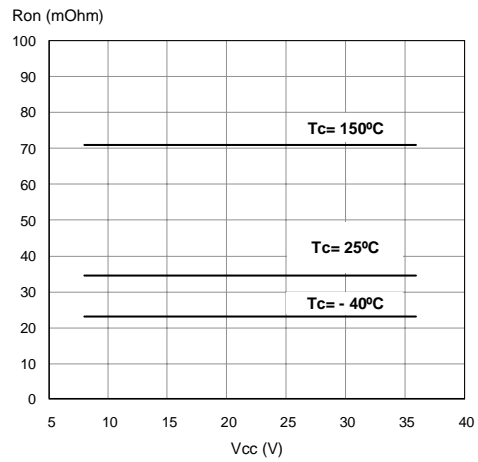

Status Clamp Voltage

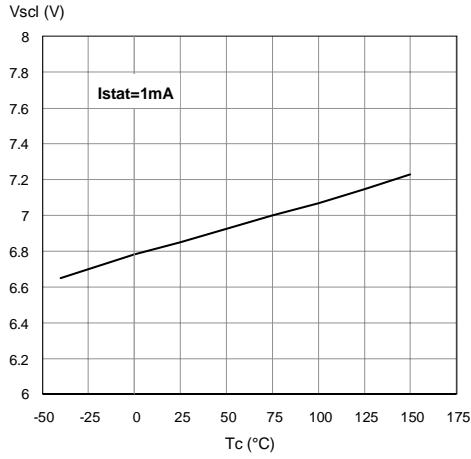

Status Leakage Current

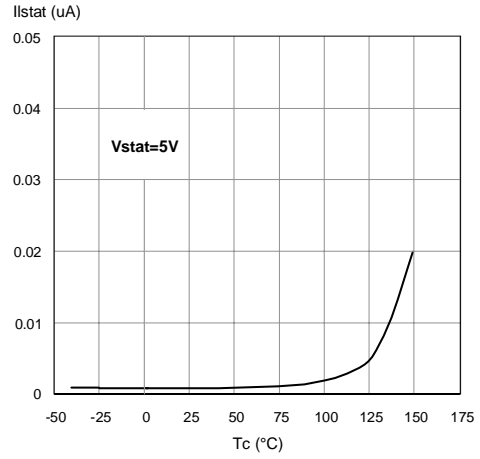

Status Low Output Voltage

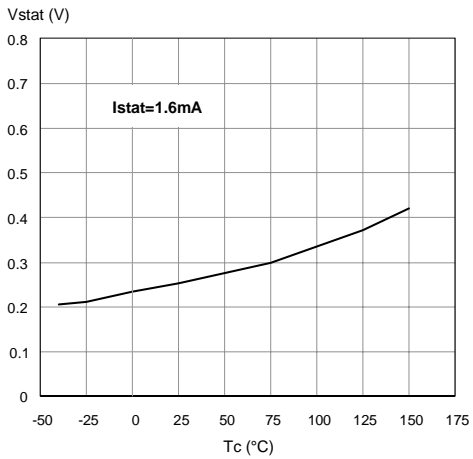

Open Load Off State Voltage Detection Threshold

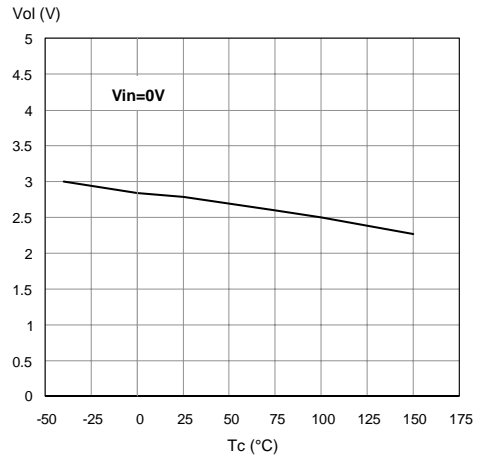

Open Load On State Detection Threshold

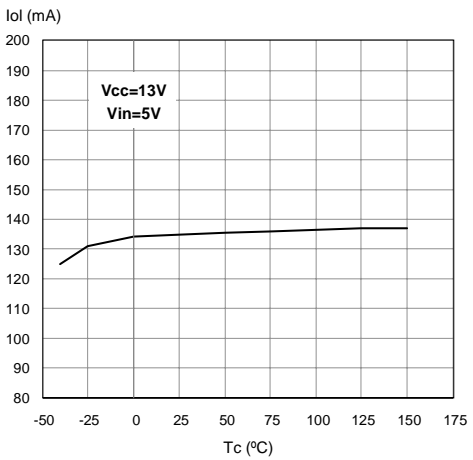

PowerSO-10, P<sup>2</sup>PAK, PENTAWATT Maximum turn off current versus load inductance

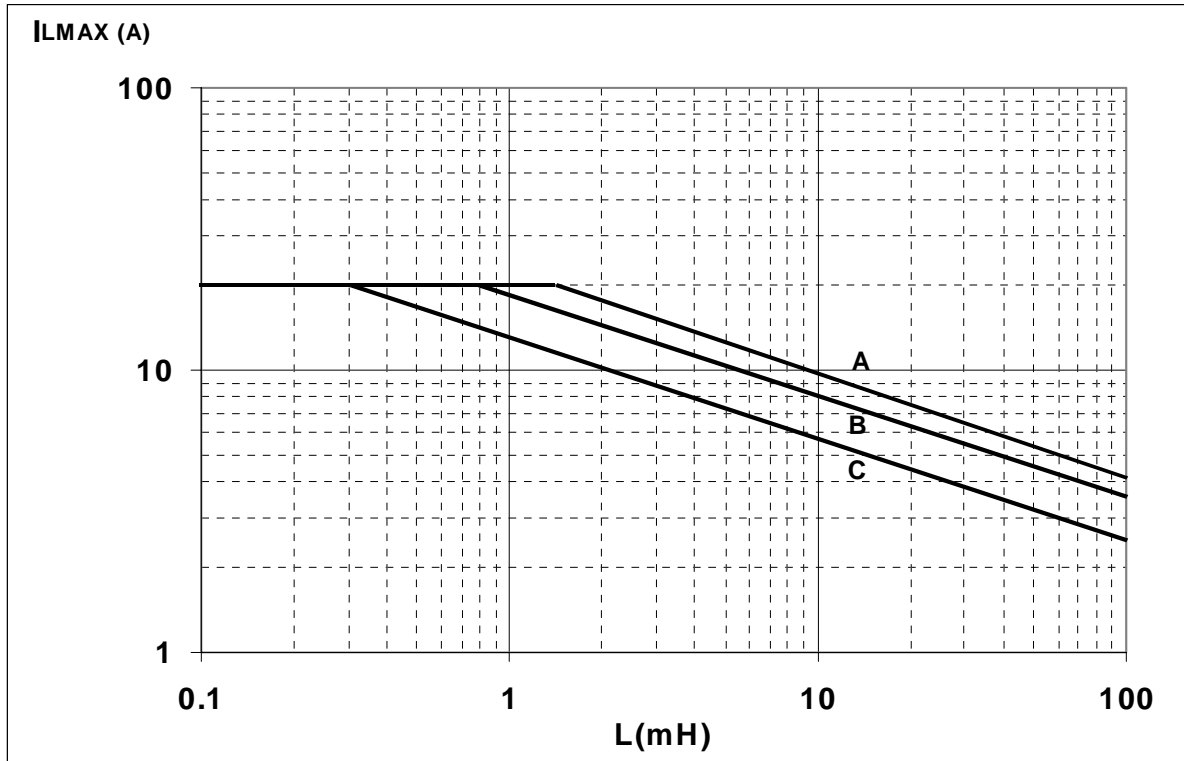

- A = Single Pulse at  $T_{Jstart}=150^{\circ}C$
- B= Repetitive pulse at  $T_{Jstart}=100^{\circ}C$
- C= Repetitive Pulse at  $T_{Jstart}=125^{\circ}C$

Conditions:

$V_{CC}=13.5V$

Values are generated with  $R_L=0\Omega$

In case of repetitive pulses,  $T_{Jstart}$  (at beginning of each demagnetization) of every pulse must not exceed the temperature specified above for curves B and C.

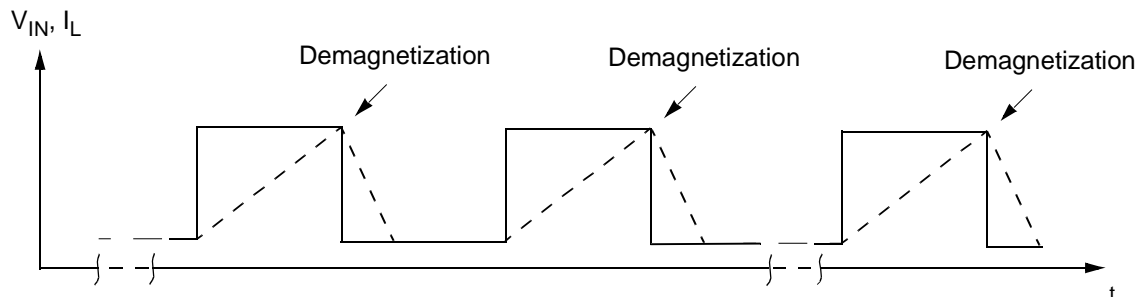

PPAK Maximum turn off current versus load inductance

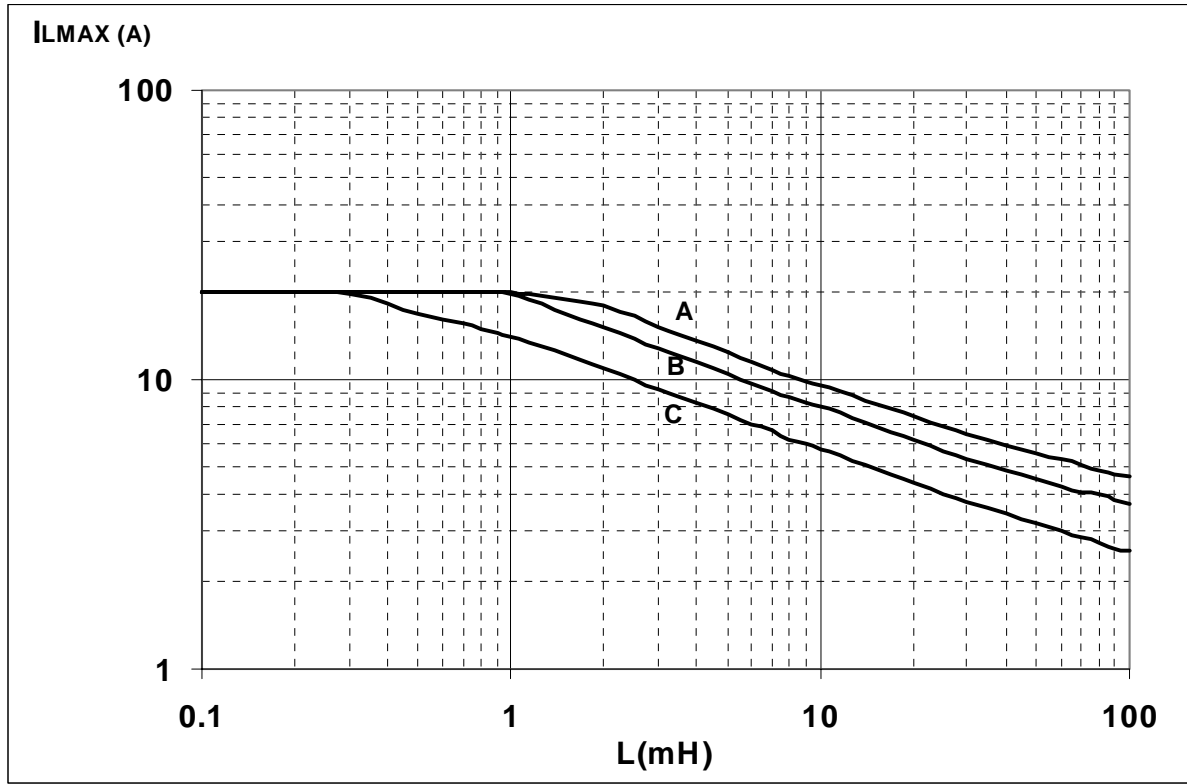

- A = Single Pulse at  $T_{Jstart}=150^{\circ}C$
- B= Repetitive pulse at  $T_{Jstart}=100^{\circ}C$
- C= Repetitive Pulse at  $T_{Jstart}=125^{\circ}C$

Conditions:

$V_{CC}=13.5V$

Values are generated with  $R_L=0\Omega$

In case of repetitive pulses,  $T_{Jstart}$  (at beginning of each demagnetization) of every pulse must not exceed the temperature specified above for curves B and C.

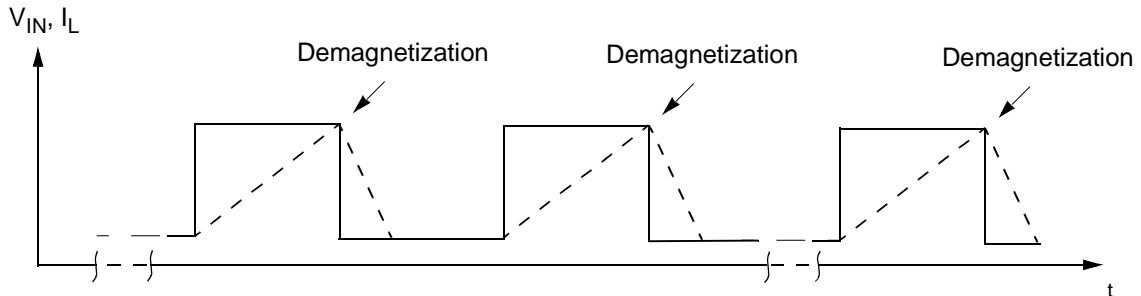

SO-16L Maximum turn off current versus load inductance



- A = Single Pulse at  $T_{Jstart}=150^{\circ}C$
- B = Repetitive pulse at  $T_{Jstart}=100^{\circ}C$
- C = Repetitive Pulse at  $T_{Jstart}=125^{\circ}C$

Conditions:

$V_{CC}=13.5V$

Values are generated with  $R_L=0\Omega$

In case of repetitive pulses,  $T_{Jstart}$  (at beginning of each demagnetization) of every pulse must not exceed the temperature specified above for curves B and C.

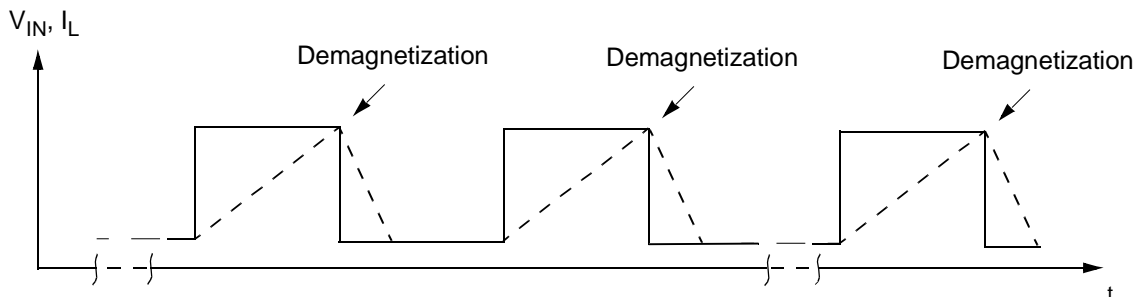

**SO-16L THERMAL DATA**

**SO-16L PC Board**

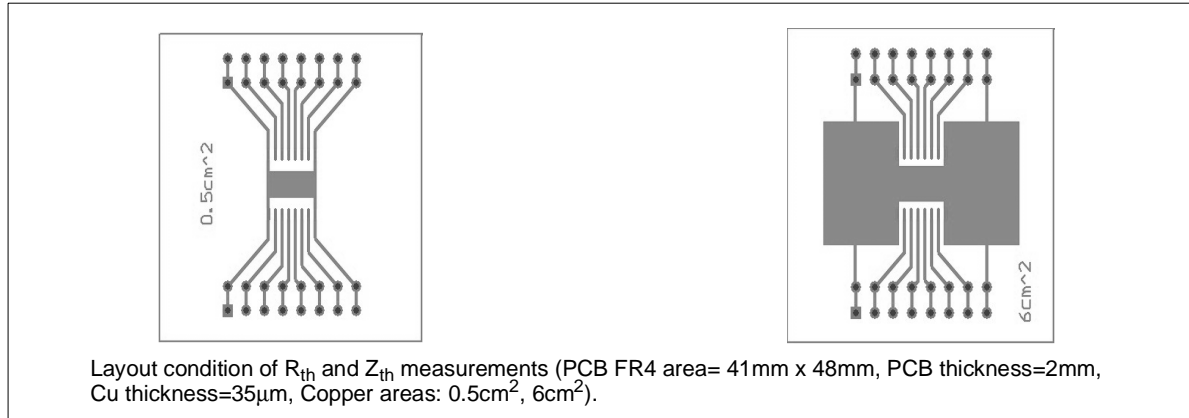

**$R_{thj-amb}$  Vs PCB copper area in open box free air condition**

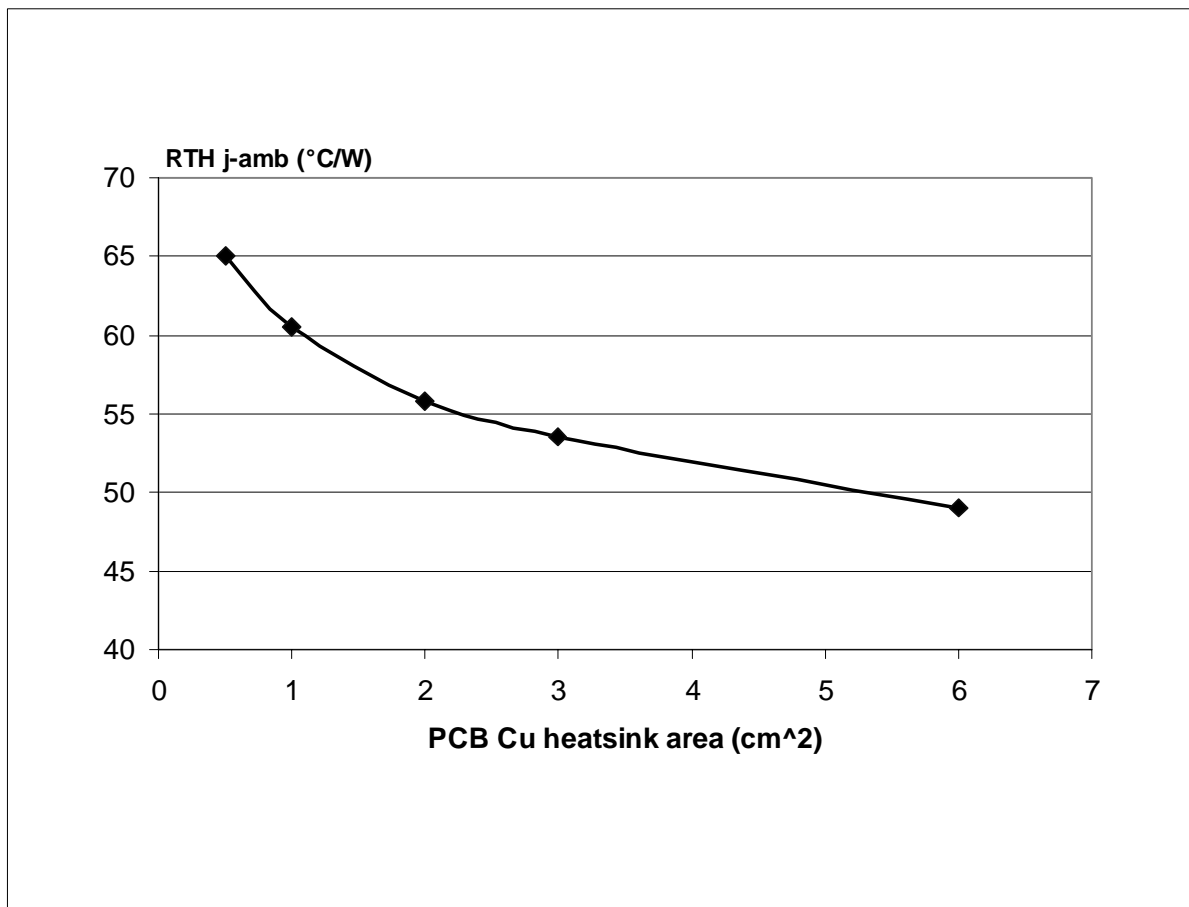

**P<sup>2</sup>PAK THERMAL DATA**

**P<sup>2</sup>PAK PC Board**



Layout condition of  $R_{th}$  and  $Z_{th}$  measurements (PCB FR4 area= 60mm x 60mm, PCB thickness=2mm, Cu thickness=35 $\mu$ m, Copper areas: 0.97cm<sup>2</sup>, 8cm<sup>2</sup>).

**$R_{thj-amb}$  Vs PCB copper area in open box free air condition**

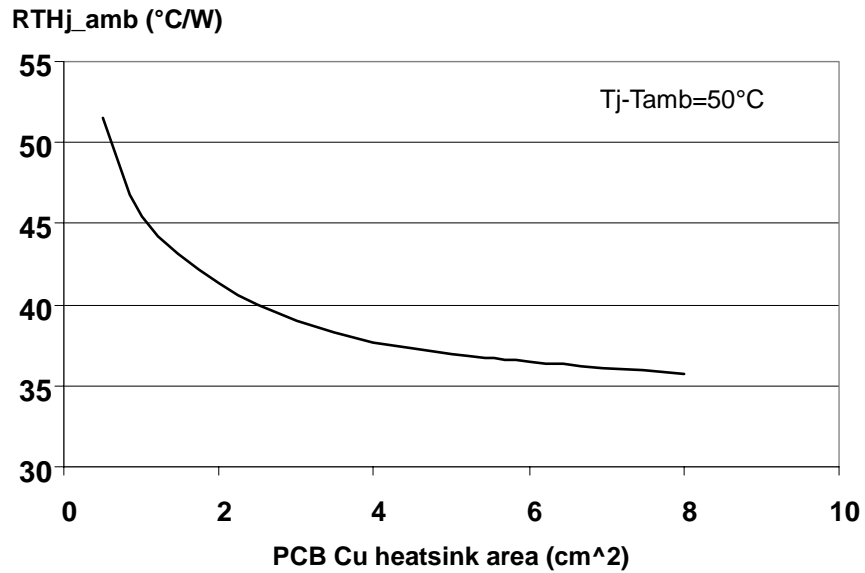

**PPAK THERMAL DATA**

**PPAK PC Board**

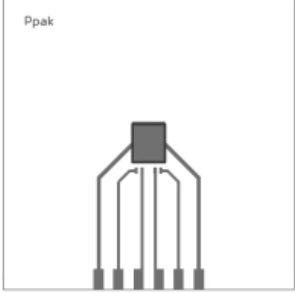

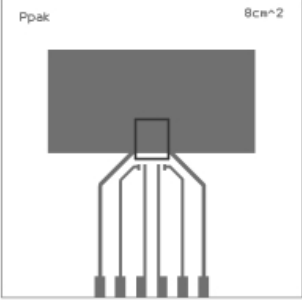

Layout condition of  $R_{th}$  and  $Z_{th}$  measurements (PCB FR4 area= 60mm x 60mm, PCB thickness=2mm, Cu thickness=35 $\mu$ m, Copper areas: 0.44cm<sup>2</sup>, 8cm<sup>2</sup>).

**$R_{thj-amb}$  Vs PCB copper area in open box free air condition**

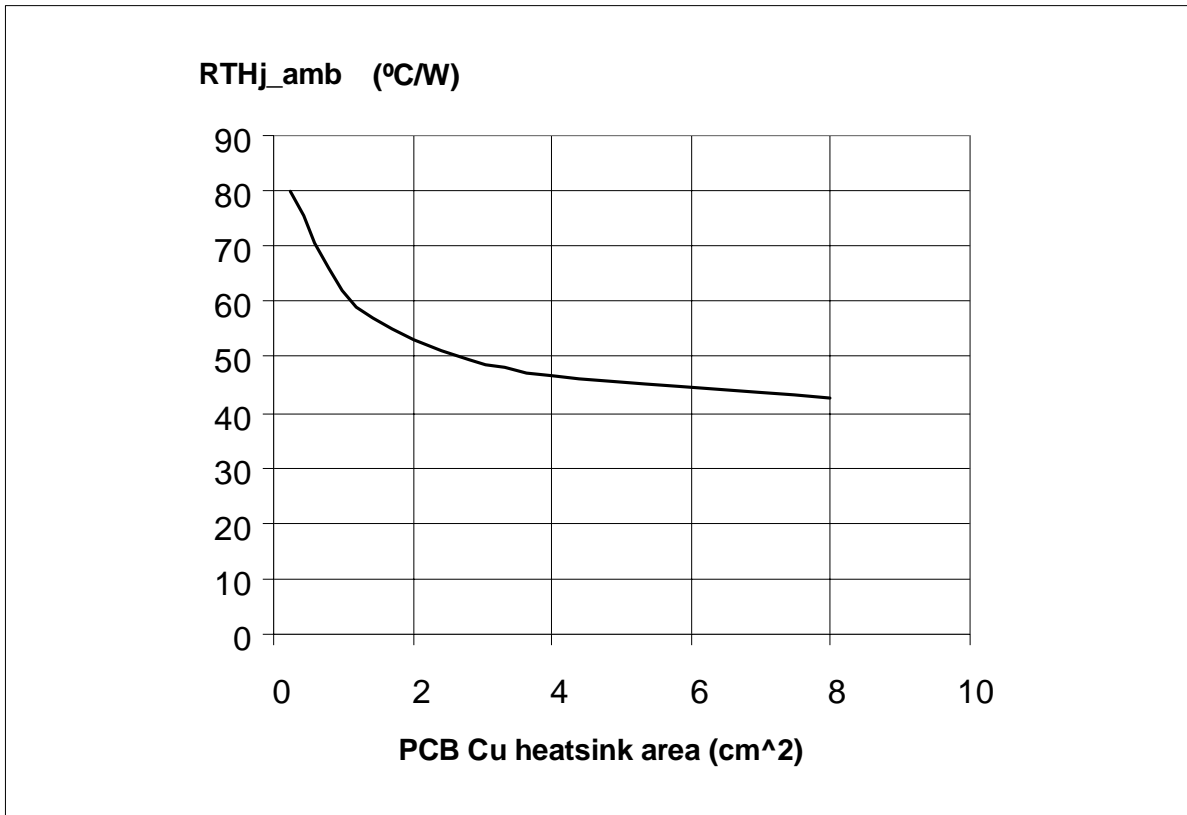

**PowerSO-10™ THERMAL DATA**

**PowerSO-10™ PC Board**

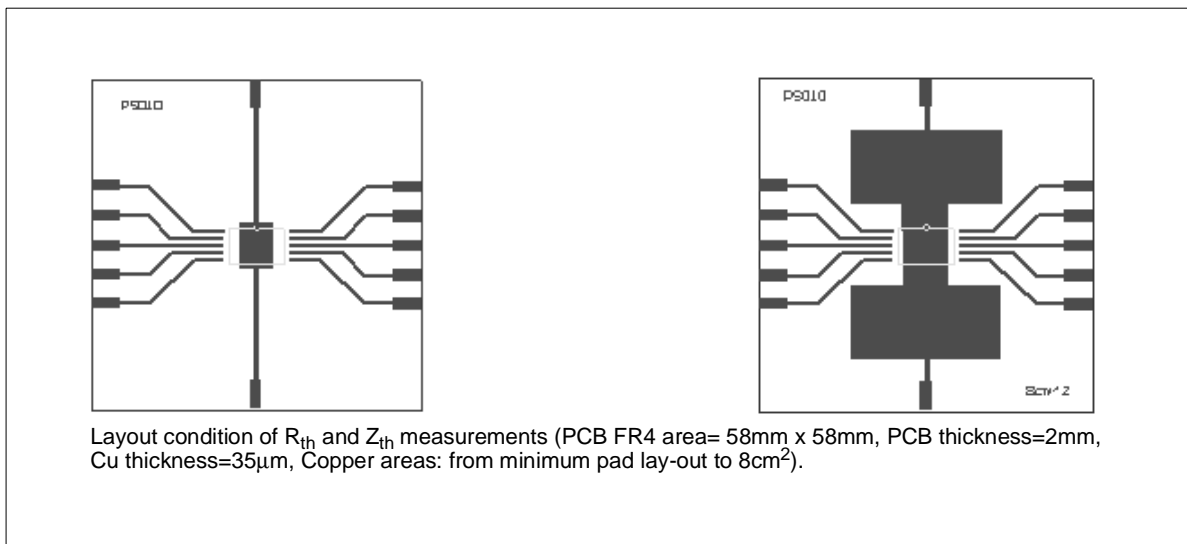

**$R_{thj-amb}$  Vs PCB copper area in open box free air condition**

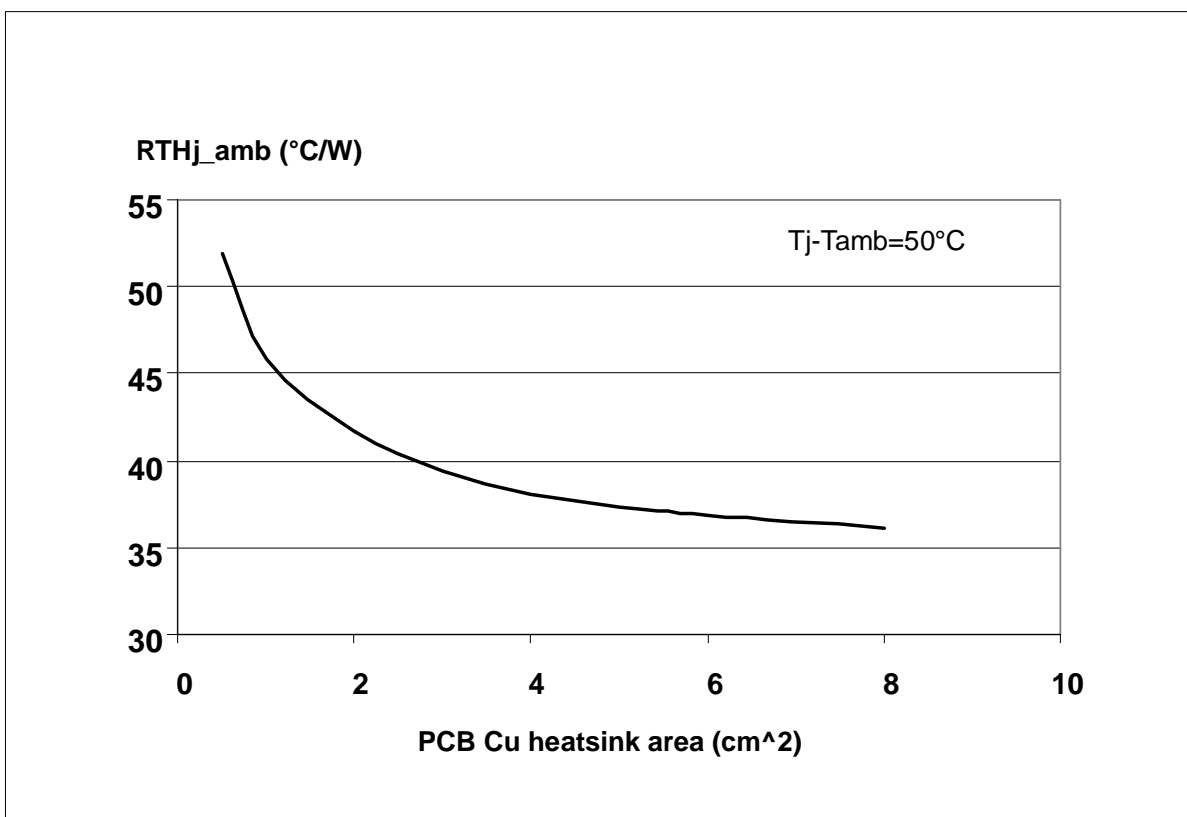

PowerSO-10 Thermal Impedance Junction Ambient Single Pulse

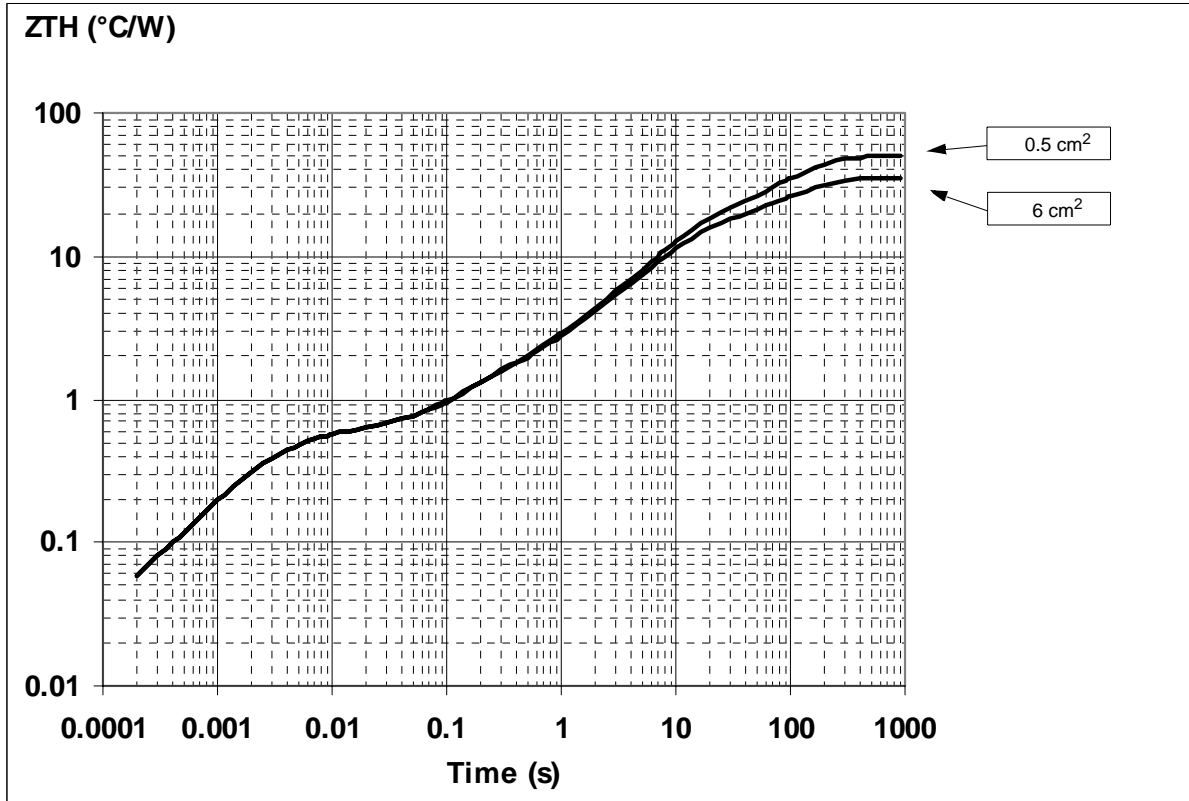

Thermal fitting model of a single channel HSD in PowerSO-10

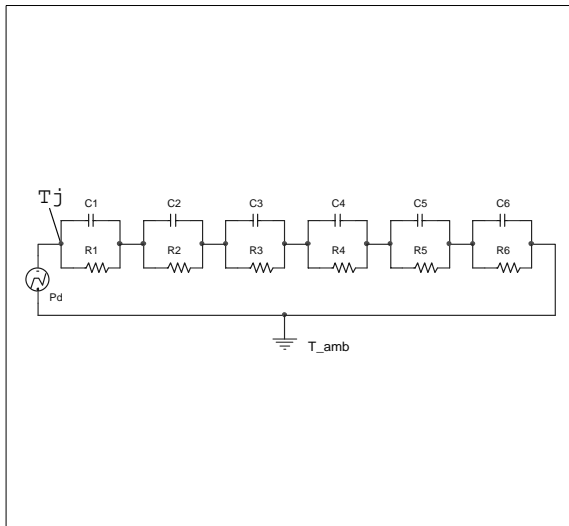

Pulse calculation formula

$$Z_{TH\delta} = R_{TH} \cdot \delta + Z_{THtp}(1 - \delta)$$

where  $\delta = t_p/T$

Thermal Parameter

| Area/island (cm <sup>2</sup> ) | 0.5      | 6  |
|--------------------------------|----------|----|
| R1 (°C/W)                      | 0.04     |    |
| R2 (°C/W)                      | 0.25     |    |
| R3 (°C/W)                      | 0.25     |    |
| R4 (°C/W)                      | 0.8      |    |
| R5 (°C/W)                      | 12       |    |
| R6 (°C/W)                      | 37       | 22 |
| C1 (W.s/°C)                    | 0.0008   |    |
| C2 (W.s/°C)                    | 7.00E-03 |    |
| C3 (W.s/°C)                    | 0.015    |    |
| C4 (W.s/°C)                    | 0.3      |    |
| C5 (W.s/°C)                    | 0.75     |    |
| C6 (W.s/°C)                    | 3        | 5  |

P<sup>2</sup>PAK Thermal Impedance Junction Ambient Single Pulse

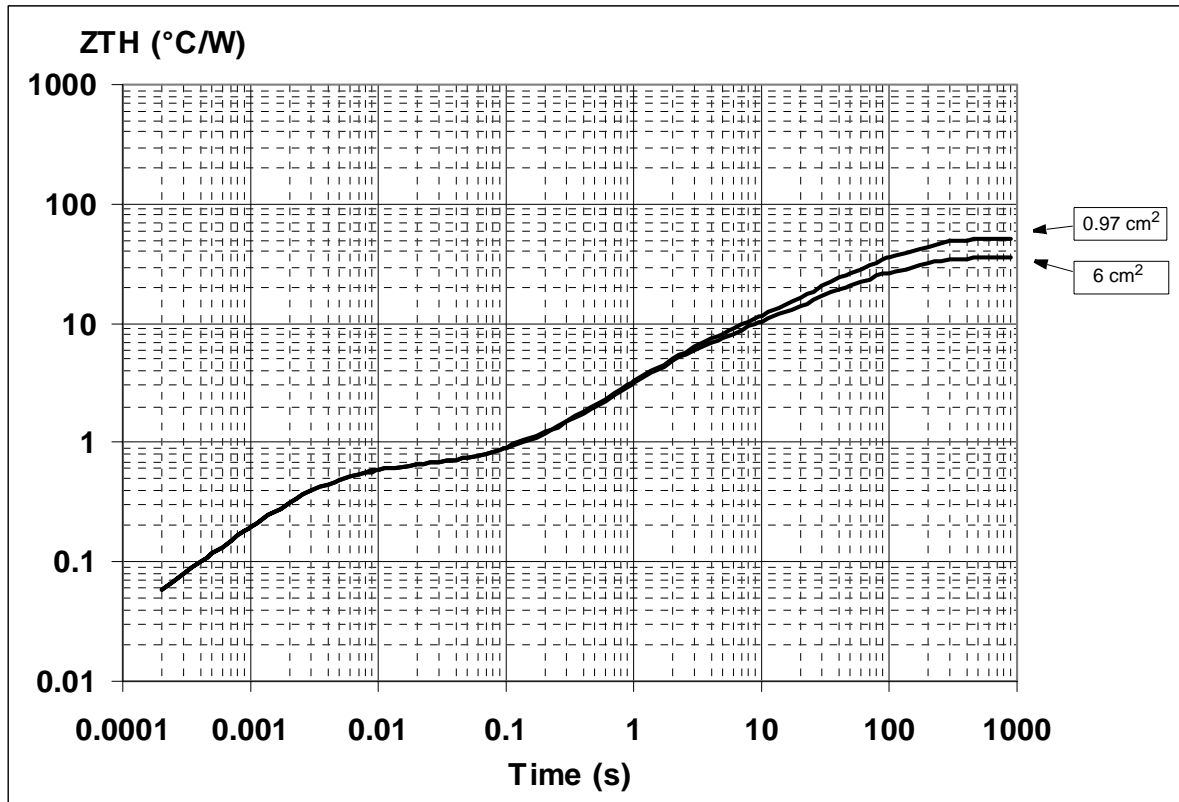

Thermal fitting model of a single channel HSD in P<sup>2</sup>PAK

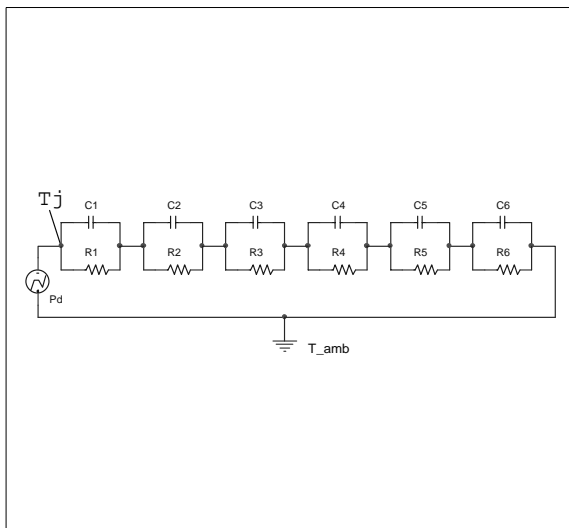

Pulse calculation formula

$$Z_{TH\delta} = R_{TH} \cdot \delta + Z_{THtp}(1 - \delta)$$

where  $\delta = t_p/T$

Thermal Parameter

| Area/island (cm <sup>2</sup> ) | 0.97   | 6  |
|--------------------------------|--------|----|
| R1 (°C/W)                      | 0.04   |    |
| R2 (°C/W)                      | 0.25   |    |
| R3 (°C/W)                      | 0.3    |    |
| R4 (°C/W)                      | 4      |    |
| R5 (°C/W)                      | 9      |    |
| R6 (°C/W)                      | 37     | 22 |
| C1 (W.s/°C)                    | 0.0008 |    |
| C2 (W.s/°C)                    | 0.007  |    |
| C3 (W.s/°C)                    | 0.015  |    |
| C4 (W.s/°C)                    | 0.4    |    |
| C5 (W.s/°C)                    | 2      |    |
| C6 (W.s/°C)                    | 3      | 5  |

PPAK Thermal Impedance Junction Ambient Single Pulse

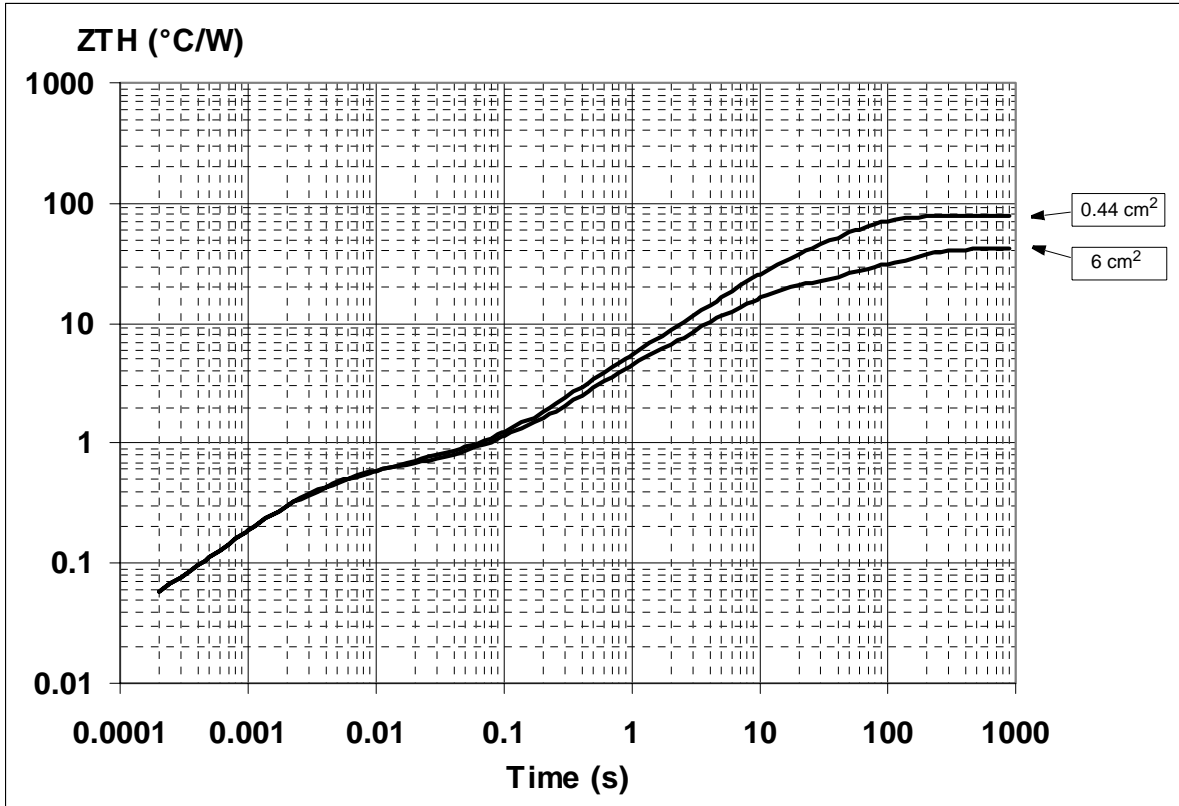

Thermal fitting model of a single channel HSD in PPAK

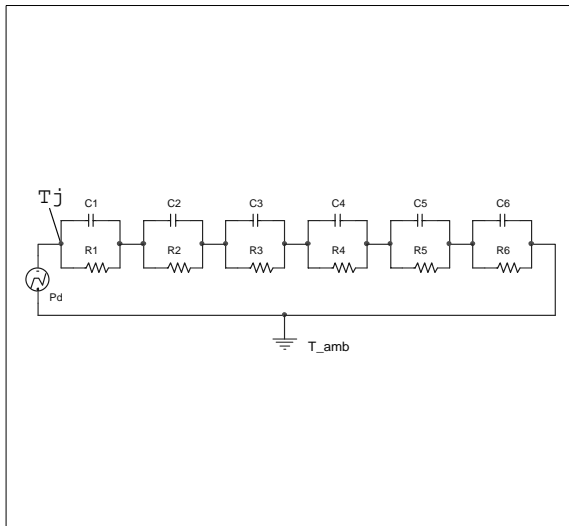

Pulse calculation formula

$$Z_{TH\delta} = R_{TH} \cdot \delta + Z_{THtp}(1 - \delta)$$

where  $\delta = t_p/T$

Thermal Parameter

| Area/island (cm <sup>2</sup> ) | 0.44   | 6  |
|--------------------------------|--------|----|
| R1 (°C/W)                      | 0.04   |    |
| R2 (°C/W)                      | 0.25   |    |
| R3 (°C/W)                      | 0.3    |    |
| R4 (°C/W)                      | 2      |    |
| R5 (°C/W)                      | 15     |    |
| R6 (°C/W)                      | 61     | 24 |
| C1 (W.s/°C)                    | 0.0008 |    |
| C2 (W.s/°C)                    | 0.007  |    |
| C3 (W.s/°C)                    | 0.02   |    |
| C4 (W.s/°C)                    | 0.3    |    |
| C5 (W.s/°C)                    | 0.45   |    |
| C6 (W.s/°C)                    | 0.8    | 5  |

SO-16L Thermal Impedance Junction Ambient Single Pulse

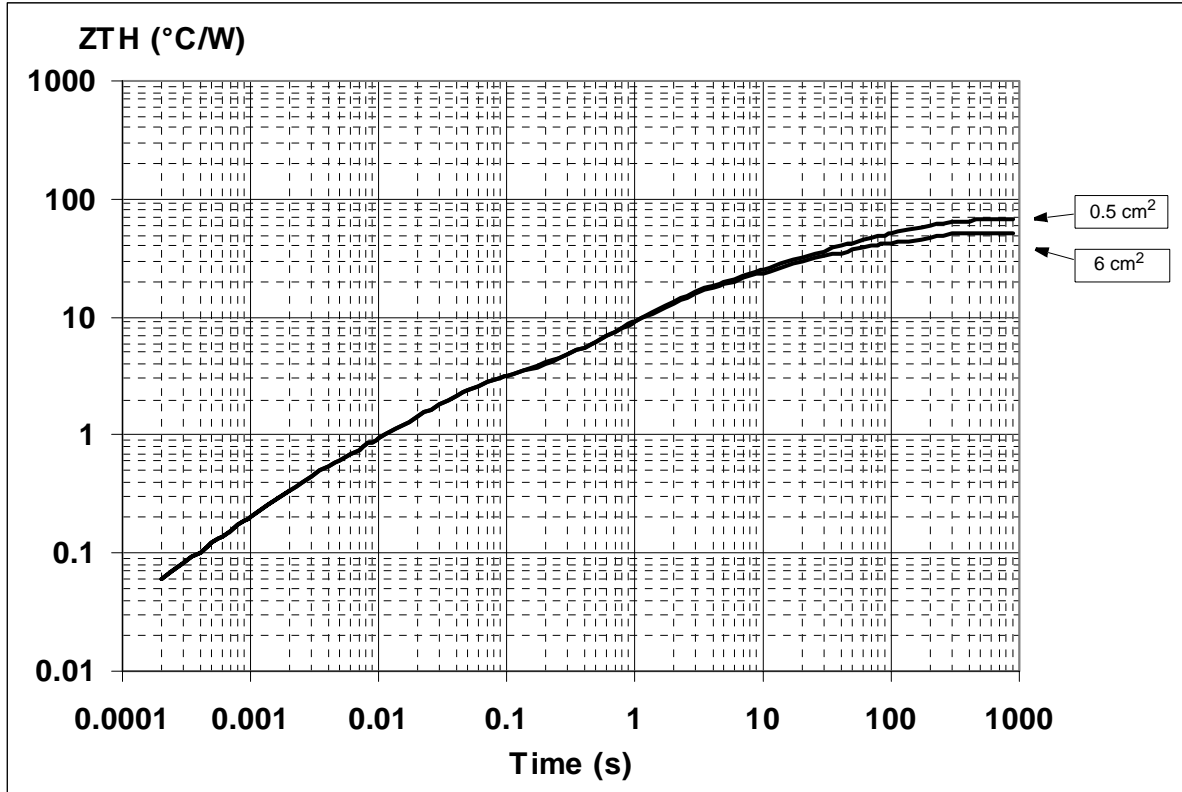

Thermal fitting model of a single channel HSD in SO-16L

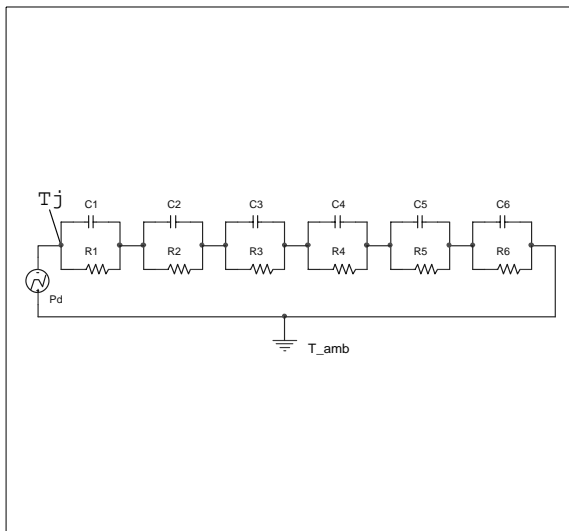

Pulse calculation formula

$$Z_{TH\delta} = R_{TH} \cdot \delta + Z_{THtp}(1 - \delta)$$

where  $\delta = t_p/T$

Thermal Parameter

| Area/island (cm <sup>2</sup> ) | 0.5      | 6  |
|--------------------------------|----------|----|
| R1 (°C/W)                      | 0.04     |    |
| R2 (°C/W)                      | 0.25     |    |
| R3 (°C/W)                      | 2.2      |    |
| R4 (°C/W)                      | 12       |    |
| R5 (°C/W)                      | 15       |    |
| R6 (°C/W)                      | 37       | 22 |
| C1 (W.s/°C)                    | 0.0008   |    |
| C2 (W.s/°C)                    | 7.00E-03 |    |
| C3 (W.s/°C)                    | 1.50E-02 |    |
| C4 (W.s/°C)                    | 0.14     |    |
| C5 (W.s/°C)                    | 1        |    |
| C6 (W.s/°C)                    | 3        | 5  |

**PowerSO-10™ MECHANICAL DATA**

| DIM.   | mm.   |      |       | inch  |       |        |
|--------|-------|------|-------|-------|-------|--------|
|        | MIN.  | TYP. | MAX.  | MIN.  | TYP.  | MAX.   |
| A      | 3.35  |      | 3.65  | 0.132 |       | 0.144  |
| A (*)  | 3.4   |      | 3.6   | 0.134 |       | 0.142  |
| A1     | 0.00  |      | 0.10  | 0.000 |       | 0.004  |
| B      | 0.40  |      | 0.60  | 0.016 |       | 0.024  |
| B (*)  | 0.37  |      | 0.53  | 0.014 |       | 0.021  |
| C      | 0.35  |      | 0.55  | 0.013 |       | 0.022  |
| C (*)  | 0.23  |      | 0.32  | 0.009 |       | 0.0126 |
| D      | 9.40  |      | 9.60  | 0.370 |       | 0.378  |
| D1     | 7.40  |      | 7.60  | 0.291 |       | 0.300  |
| E      | 9.30  |      | 9.50  | 0.366 |       | 0.374  |
| E2     | 7.20  |      | 7.60  | 0.283 |       | 300    |
| E2 (*) | 7.30  |      | 7.50  | 0.287 |       | 0.295  |
| E4     | 5.90  |      | 6.10  | 0.232 |       | 0.240  |
| E4 (*) | 5.90  |      | 6.30  | 0.232 |       | 0.248  |
| e      |       | 1.27 |       |       | 0.050 |        |
| F      | 1.25  |      | 1.35  | 0.049 |       | 0.053  |
| F (*)  | 1.20  |      | 1.40  | 0.047 |       | 0.055  |
| H      | 13.80 |      | 14.40 | 0.543 |       | 0.567  |
| H (*)  | 13.85 |      | 14.35 | 0.545 |       | 0.565  |
| h      |       | 0.50 |       |       | 0.002 |        |
| L      | 1.20  |      | 1.80  | 0.047 |       | 0.070  |
| L (*)  | 0.80  |      | 1.10  | 0.031 |       | 0.043  |
| α      | 0°    |      | 8°    | 0°    |       | 8°     |
| α (*)  | 2°    |      | 8°    | 2°    |       | 8°     |

(\*) Muar only POA P013P

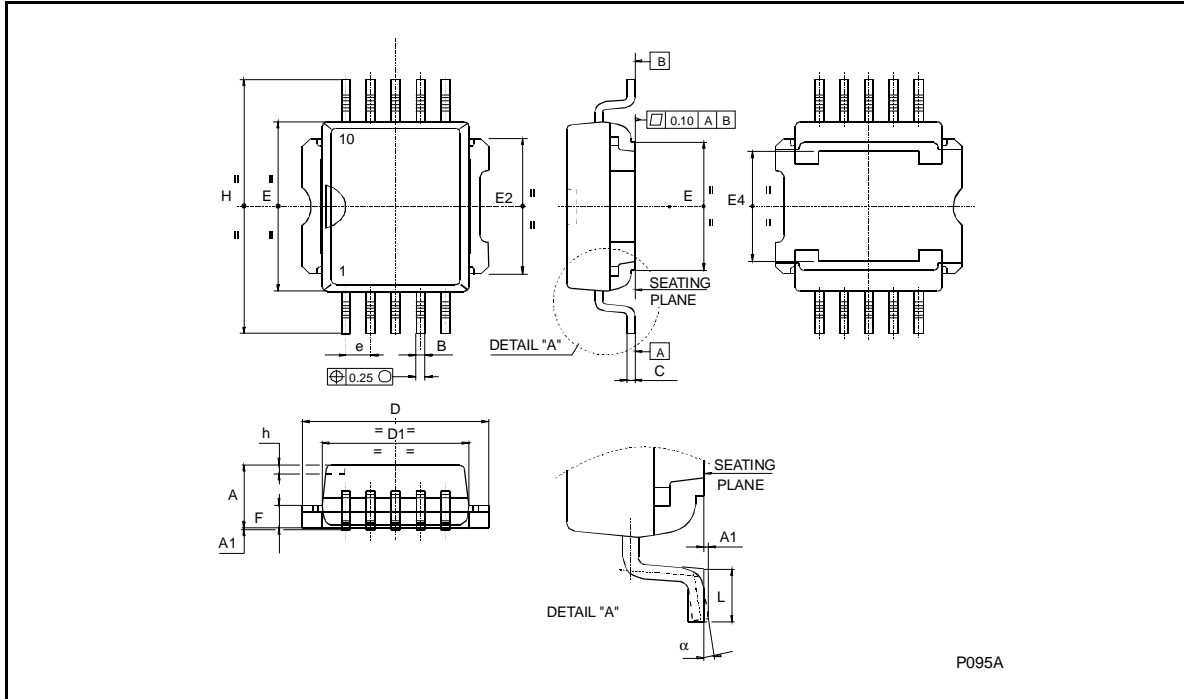

**PENTAWATT (VERTICAL) MECHANICAL DATA**

| DIM.  | mm.   |       |      | inch  |       |       |
|-------|-------|-------|------|-------|-------|-------|
|       | MIN.  | TYP.  | MAX. | MIN.  | TYP.  | MAX.  |
| A     |       |       | 4.8  |       |       | 0.189 |
| C     |       |       | 1.37 |       |       | 0.054 |
| D     | 2.4   |       | 2.8  | 0.094 |       | 0.110 |
| D1    | 1.2   |       | 1.35 | 0.047 |       | 0.053 |
| E     | 0.35  |       | 0.55 | 0.014 |       | 0.022 |
| F     | 0.8   |       | 1.05 | 0.031 |       | 0.041 |
| F1    | 1     |       | 1.4  | 0.039 |       | 0.055 |
| G     | 3.2   | 3.4   | 3.6  | 0.126 | 0.134 | 0.142 |
| G1    | 6.6   | 6.8   | 7    | 0.260 | 0.268 | 0.276 |
| H2    |       |       | 10.4 |       |       | 0.409 |
| H3    | 10.05 |       | 10.4 | 0.396 |       | 0.409 |
| L     |       | 17.85 |      |       | 0.703 |       |
| L1    |       | 15.75 |      |       | 0.620 |       |
| L2    |       | 21.4  |      |       | 0.843 |       |
| L3    |       | 22.5  |      |       | 0.886 |       |
| L5    | 2.6   |       | 3    | 0.102 |       | 0.118 |
| L6    | 15.1  |       | 15.8 | 0.594 |       | 0.622 |
| L7    | 6     |       | 6.6  | 0.236 |       | 0.260 |
| M     |       | 4.5   |      |       | 0.177 |       |
| M1    |       | 4     |      |       | 0.157 |       |
| Diam. | 3.65  |       | 3.85 | 0.144 |       | 0.152 |

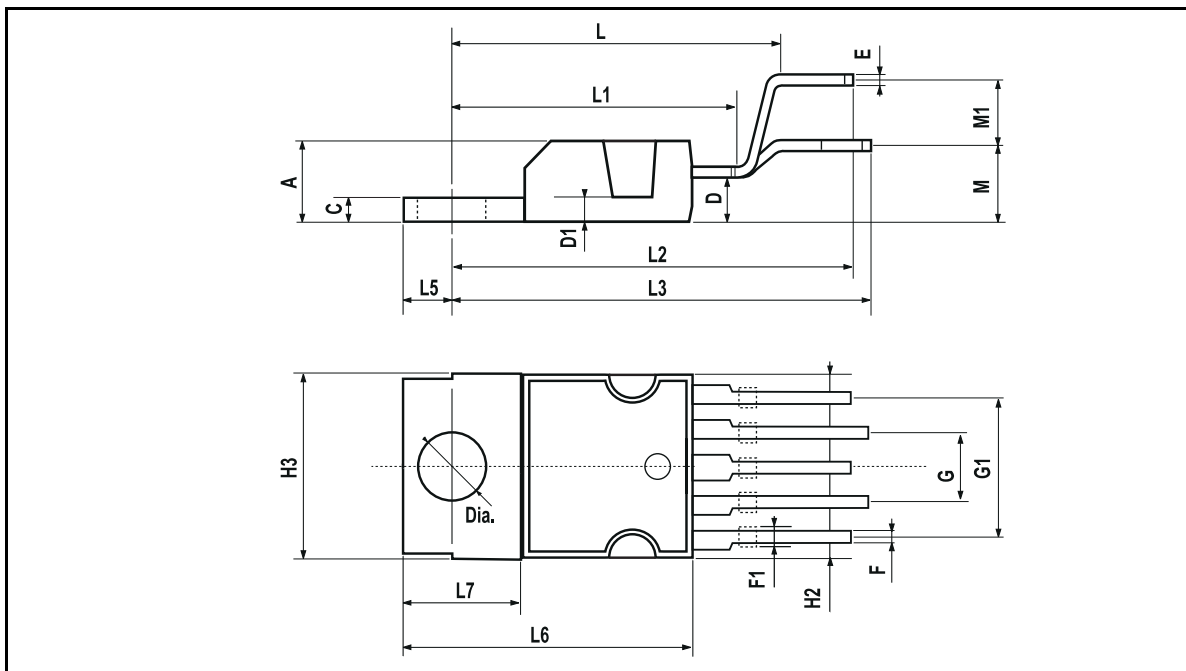

## P<sup>2</sup>PAK MECHANICAL DATA

| DIM.           | mm.           |      |       |
|----------------|---------------|------|-------|
|                | MIN.          | TYP  | MAX.  |
| A              | 4.30          |      | 4.80  |
| A1             | 2.40          |      | 2.80  |
| A2             | 0.03          |      | 0.23  |
| b              | 0.80          |      | 1.05  |
| c              | 0.45          |      | 0.60  |
| c2             | 1.17          |      | 1.37  |
| D              | 8.95          |      | 9.35  |
| D2             |               | 8.00 |       |
| E              | 10.00         |      | 10.40 |
| E1             |               | 8.50 |       |
| e              | 3.20          |      | 3.60  |
| e1             | 6.60          |      | 7.00  |
| L              | 13.70         |      | 14.50 |
| L2             | 1.25          |      | 1.40  |
| L3             | 0.90          |      | 1.70  |
| L5             | 1.55          |      | 2.40  |
| R              |               | 0.40 |       |
| V2             | 0°            |      | 8°    |
| Package Weight | 1.40 Gr (typ) |      |       |

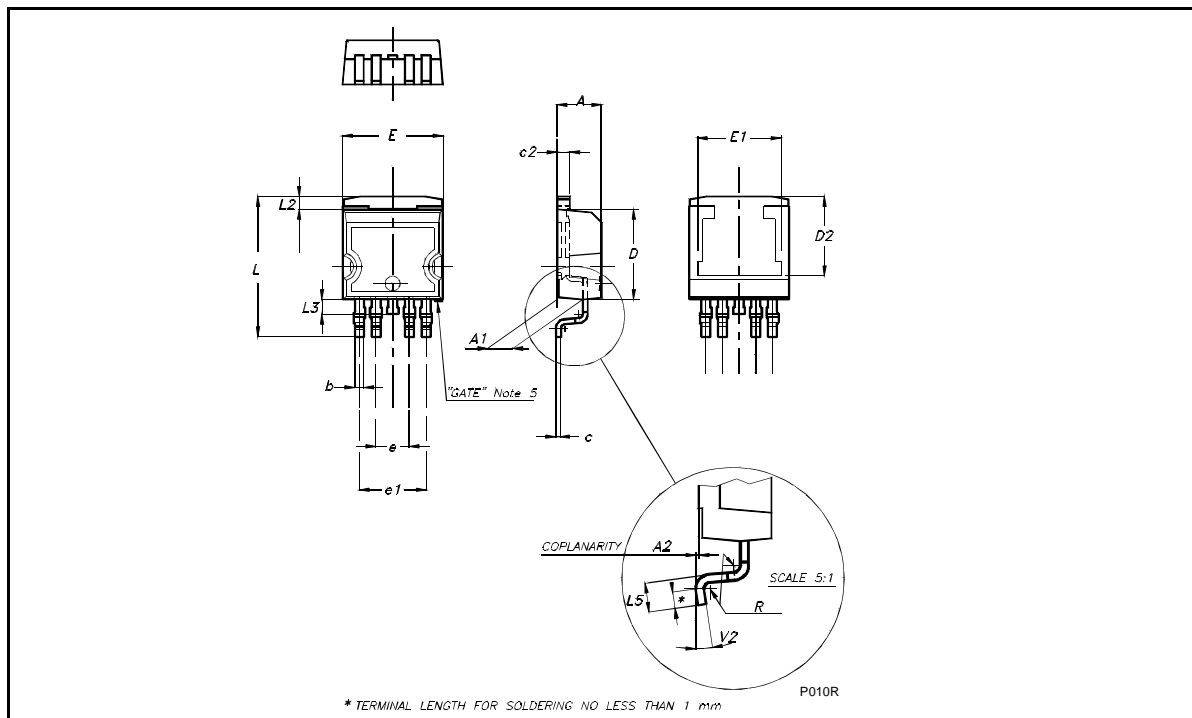

**SO-16L MECHANICAL DATA**

| DIM. | mm.        |      |       | inch  |       |       |
|------|------------|------|-------|-------|-------|-------|
|      | MIN.       | TYP  | MAX.  | MIN.  | TYP.  | MAX.  |
| A    |            |      | 2.65  |       |       | 0.104 |
| a1   | 0.1        |      | 0.2   | 0.004 |       | 0.008 |
| a2   |            |      | 2.45  |       |       | 0.096 |
| b    | 0.35       |      | 0.49  | 0.014 |       | 0.019 |
| b1   | 0.23       |      | 0.32  | 0.009 |       | 0.012 |
| C    |            | 0.5  |       |       | 0.020 |       |
| c1   | 45° (typ.) |      |       |       |       |       |
| D    | 10.1       |      | 10.5  | 0.397 |       | 0.413 |
| E    | 10.0       |      | 10.65 | 0.393 |       | 0.419 |
| e    |            | 1.27 |       |       | 0.050 |       |
| e3   |            | 8.89 |       |       | 0.350 |       |
| F    | 7.4        |      | 7.6   | 0.291 |       | 0.300 |
| L    | 0.5        |      | 1.27  | 0.020 |       | 0.050 |
| M    |            |      | 0.75  |       |       | 0.029 |
| S    | 8° (max.)  |      |       |       |       |       |

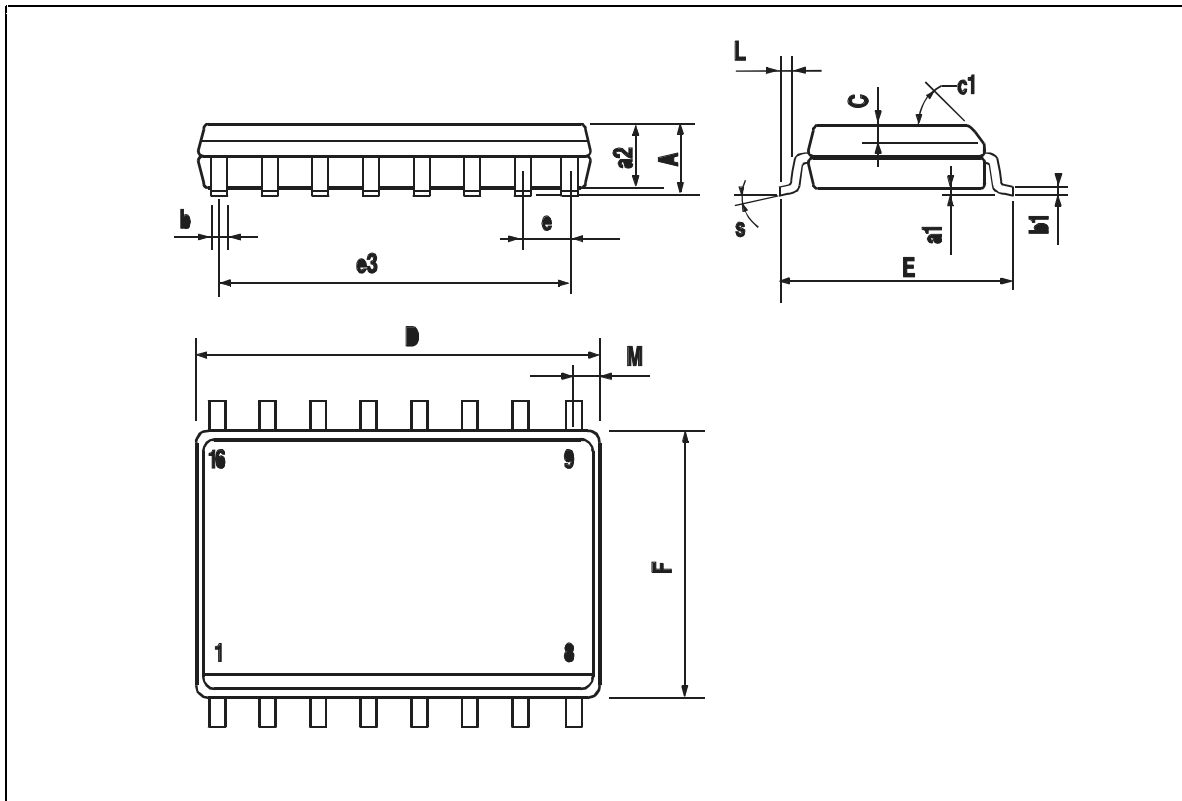

**PPAK MECHANICAL DATA**

| DIM.           | MIN.    | TYP  | MAX.  |
|----------------|---------|------|-------|
| A              | 2.20    |      | 2.40  |
| A1             | 0.90    |      | 1.10  |
| A2             | 0.03    |      | 0.23  |
| B              | 0.40    |      | 0.60  |
| B2             | 5.20    |      | 5.40  |
| C              | 0.45    |      | 0.60  |
| C2             | 0.48    |      | 0.60  |
| D1             |         | 5.1  |       |
| D              | 6.00    |      | 6.20  |
| E              | 6.40    |      | 6.60  |
| E1             |         | 4.7  |       |
| e              |         | 1.27 |       |
| G              | 4.90    |      | 5.25  |
| G1             | 2.38    |      | 2.70  |
| H              | 9.35    |      | 10.10 |
| L2             |         | 0.8  | 1.00  |
| L4             | 0.60    |      | 1.00  |
| R              |         | 0.2  |       |
| V2             | 0°      |      | 8°    |
| Package Weight | Gr. 0.3 |      |       |

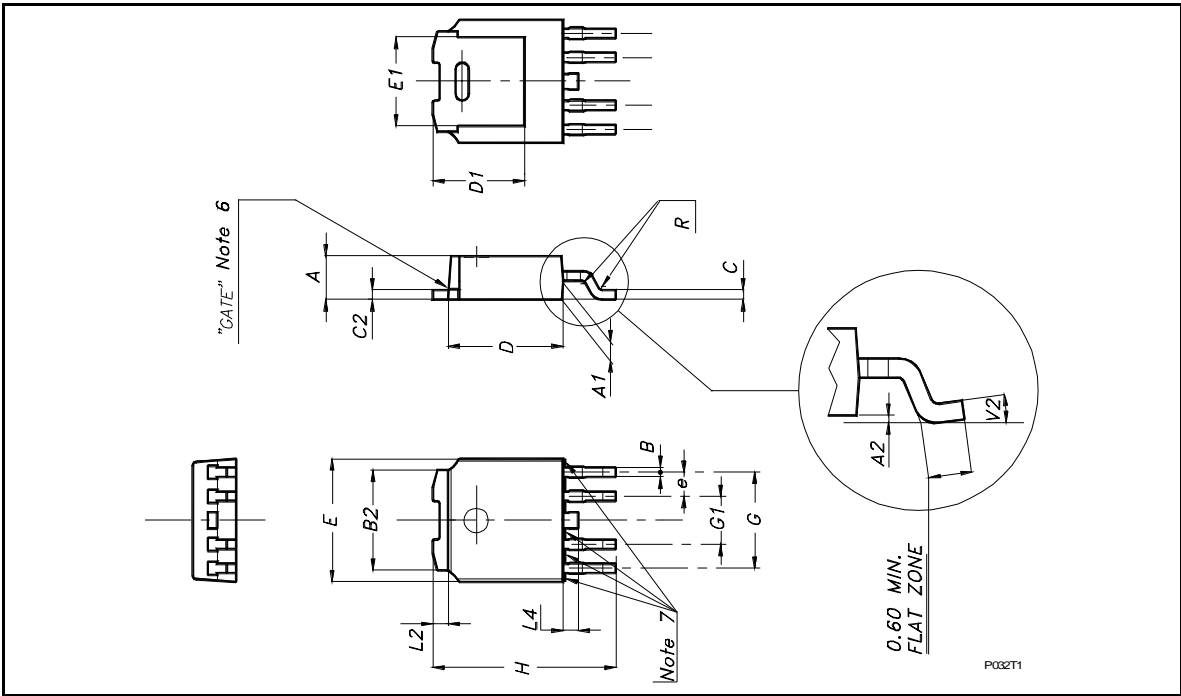

# VN820 / VN820SO / VN820SP / VN820-B5 / VN820PT

## PowerSO-10™ SUGGESTED PAD LAYOUT

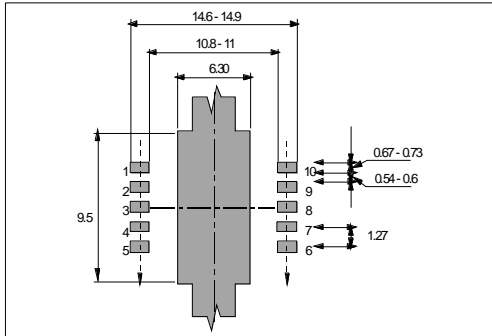

## TUBE SHIPMENT (no suffix)

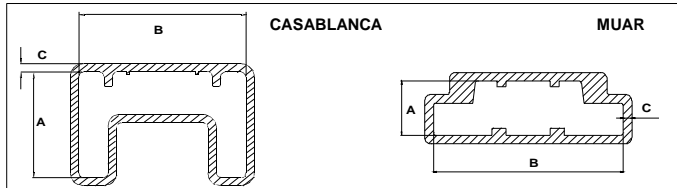

All dimensions are in mm.

|                   | Base Q.ty | Bulk Q.ty | Tube length (± 0.5) | A    | B    | C (± 0.1) |
|-------------------|-----------|-----------|---------------------|------|------|-----------|
| <b>Casablanca</b> | 50        | 1000      | 532                 | 10.4 | 16.4 | 0.8       |
| <b>Muar</b>       | 50        | 1000      | 532                 | 4.9  | 17.2 | 0.8       |

## TAPE AND REEL SHIPMENT (suffix "13TR")

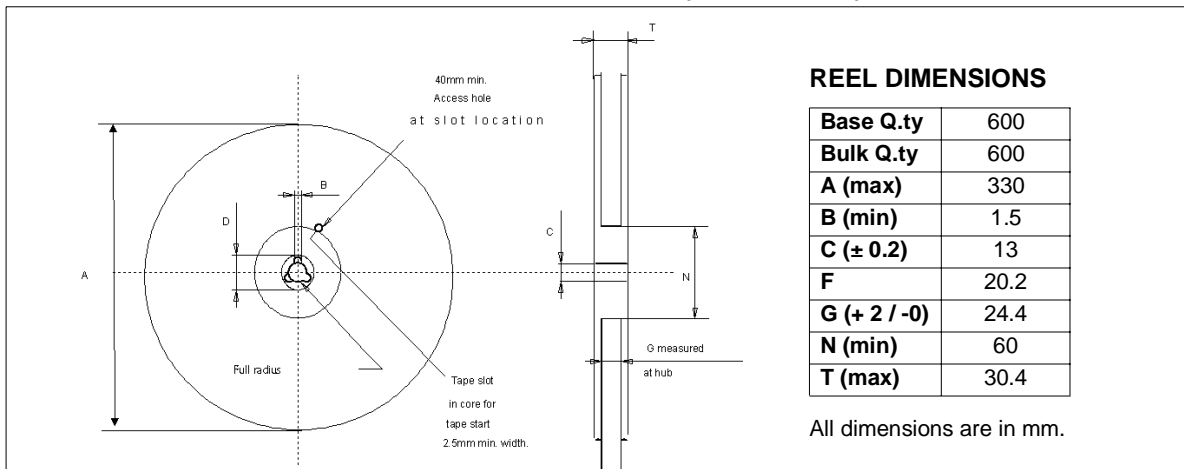

### REEL DIMENSIONS

|                     |      |
|---------------------|------|
| <b>Base Q.ty</b>    | 600  |
| <b>Bulk Q.ty</b>    | 600  |
| <b>A (max)</b>      | 330  |
| <b>B (min)</b>      | 1.5  |
| <b>C (± 0.2)</b>    | 13   |
| <b>F</b>            | 20.2 |
| <b>G (+ 2 / -0)</b> | 24.4 |
| <b>N (min)</b>      | 60   |
| <b>T (max)</b>      | 30.4 |

All dimensions are in mm.

### TAPE DIMENSIONS

According to Electronic Industries Association (EIA) Standard 481 rev. A, Feb 1986

|                          |                     |      |
|--------------------------|---------------------|------|
| <b>Tape width</b>        | <b>W</b>            | 24   |
| <b>Tape Hole Spacing</b> | <b>P0 (± 0.1)</b>   | 4    |
| <b>Component Spacing</b> | <b>P</b>            | 24   |
| <b>Hole Diameter</b>     | <b>D (± 0.1/-0)</b> | 1.5  |
| <b>Hole Diameter</b>     | <b>D1 (min)</b>     | 1.5  |
| <b>Hole Position</b>     | <b>F (± 0.05)</b>   | 11.5 |
| <b>Compartment Depth</b> | <b>K (max)</b>      | 6.5  |
| <b>Hole Spacing</b>      | <b>P1 (± 0.1)</b>   | 2    |

All dimensions are in mm.

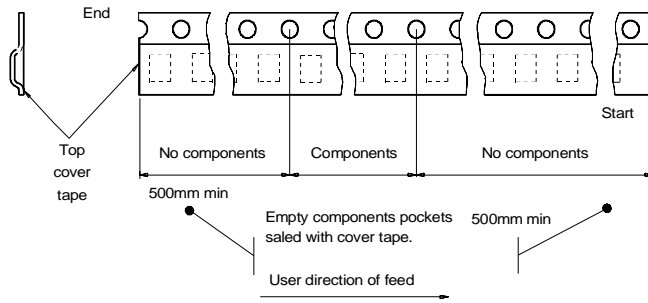
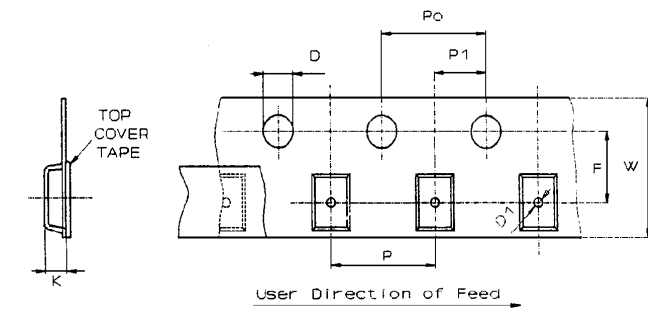
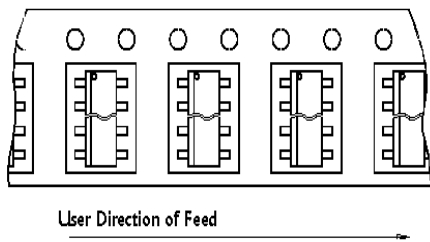

**PENTAWATT TUBE SHIPMENT (no suffix)**

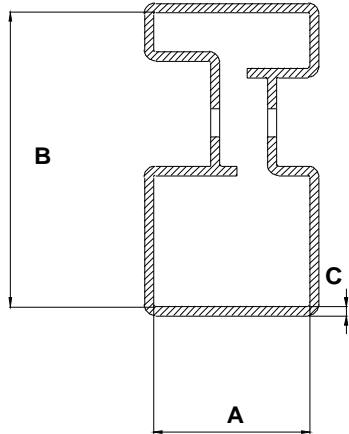

|   |      |
|---|------|
| <b>Base Q.ty</b>                          | 50   |
| <b>Bulk Q.ty</b>                          | 1000 |
| <b>Tube length (<math>\pm 0.5</math>)</b> | 532  |
| <b>A</b>                                  | 18   |
| <b>B</b>                                  | 33.1 |
| <b>C (<math>\pm 0.1</math>)</b>           | 1    |

All dimensions are in mm.

VN820 / VN820SO / VN820SP / VN820-B5 / VN820PT

P<sup>2</sup>PAK TUBE SHIPMENT (no suffix)

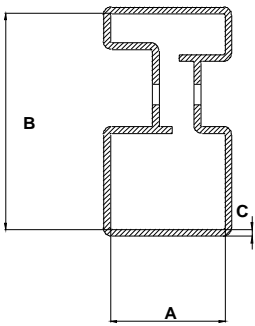

|                           |      |
|---------------------------|------|
| Base Q.ty                 | 50   |
| Bulk Q.ty                 | 1000 |
| Tube length ( $\pm 0.5$ ) | 532  |
| A                         | 18   |
| B                         | 33.1 |
| C ( $\pm 0.1$ )           | 1    |

All dimensions are in mm.

TAPE AND REEL SHIPMENT (suffix "13TR")

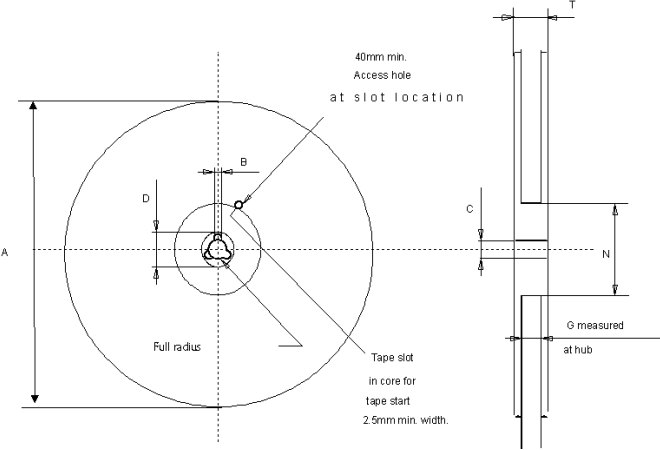

|                 |      |
|-----------------|------|
| Base Q.ty       | 1000 |
| Bulk Q.ty       | 1000 |
| A (max)         | 330  |
| B (min)         | 1.5  |
| C ( $\pm 0.2$ ) | 13   |
| F               | 20.2 |
| G (+ 2 / -0)    | 24.4 |
| N (min)         | 60   |
| T (max)         | 30.4 |

All dimensions are in mm.

**TAPE DIMENSIONS**

According to Electronic Industries Association (EIA) Standard 481 rev. A, Feb 1986

|                   |                    |      |
|-------------------|--------------------|------|
| Tape width        | W                  | 24   |
| Tape Hole Spacing | P0 ( $\pm 0.1$ )   | 4    |
| Component Spacing | P                  | 16   |
| Hole Diameter     | D ( $\pm 0.1/-0$ ) | 1.5  |
| Hole Diameter     | D1 (min)           | 1.5  |
| Hole Position     | F ( $\pm 0.05$ )   | 11.5 |
| Compartment Depth | K (max)            | 6.5  |
| Hole Spacing      | P1 ( $\pm 0.1$ )   | 2    |

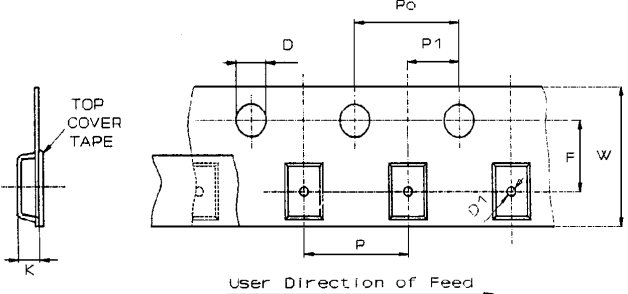

All dimensions are in mm.

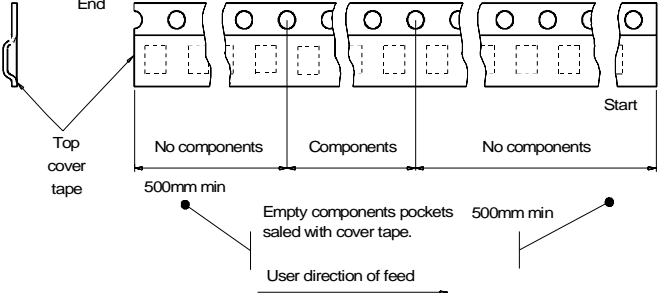

**ST**

**SO-16L TUBE SHIPMENT (no suffix)**

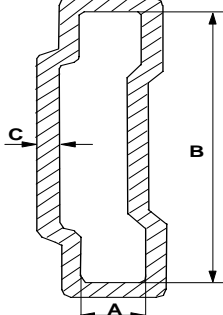

|   |      |
|---|------|
| <b>Base Q.ty</b>                          | 50   |
| <b>Bulk Q.ty</b>                          | 1000 |
| <b>Tube length (<math>\pm 0.5</math>)</b> | 532  |
| <b>A</b>                                  | 3.5  |
| <b>B</b>                                  | 13.8 |
| <b>C (<math>\pm 0.1</math>)</b>           | 0.6  |

All dimensions are in mm.

**TAPE AND REEL SHIPMENT (suffix "13TR")**

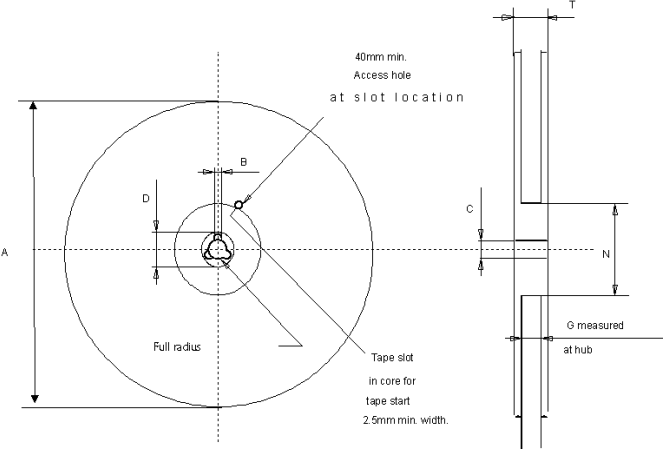

|                                 |      |
|---------------------------------|------|
| <b>Base Q.ty</b>                | 1000 |
| <b>Bulk Q.ty</b>                | 1000 |
| <b>A (max)</b>                  | 330  |
| <b>B (min)</b>                  | 1.5  |
| <b>C (<math>\pm 0.2</math>)</b> | 13   |
| <b>F</b>                        | 20.2 |
| <b>G (+ 2 / - 0)</b>            | 16.4 |
| <b>N (min)</b>                  | 60   |
| <b>T (max)</b>                  | 22.4 |

**TAPE DIMENSIONS**

According to Electronic Industries Association (EIA) Standard 481 rev. A, Feb 1986

|                          |                                    |     |
|--------------------------|------------------------------------|-----|
| <b>Tape width</b>        | <b>W</b>                           | 16  |
| <b>Tape Hole Spacing</b> | <b>P0 (<math>\pm 0.1</math>)</b>   | 4   |
| <b>Component Spacing</b> | <b>P</b>                           | 12  |
| <b>Hole Diameter</b>     | <b>D (<math>\pm 0.1/-0</math>)</b> | 1.5 |
| <b>Hole Diameter</b>     | <b>D1 (min)</b>                    | 1.5 |
| <b>Hole Position</b>     | <b>F (<math>\pm 0.05</math>)</b>   | 7.5 |
| <b>Compartment Depth</b> | <b>K (max)</b>                     | 6.5 |
| <b>Hole Spacing</b>      | <b>P1 (<math>\pm 0.1</math>)</b>   | 2   |

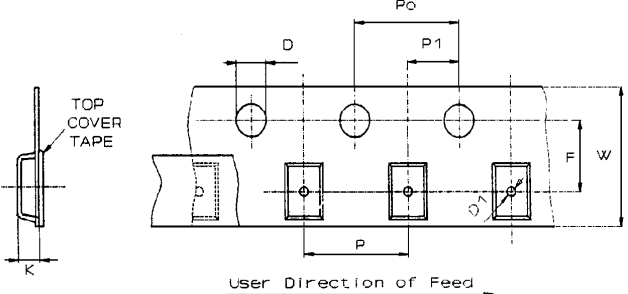

All dimensions are in mm.

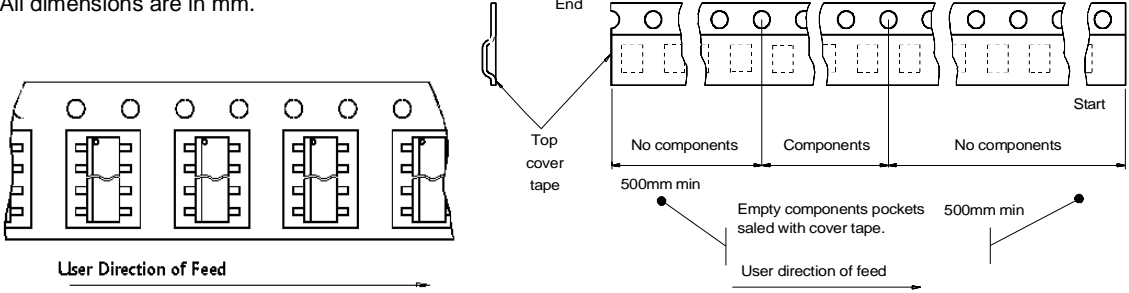

VN820 / VN820SO / VN820SP / VN820-B5 / VN820PT

PPAK TUBE SHIPMENT (no suffix)

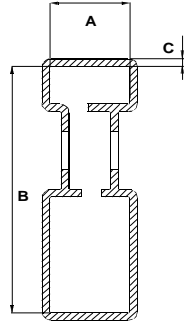

|                           |      |
|---------------------------|------|
| Base Q.ty                 | 75   |
| Bulk Q.ty                 | 3000 |
| Tube length ( $\pm 0.5$ ) | 532  |
| A                         | 6    |
| B                         | 21.3 |
| C ( $\pm 0.1$ )           | 0.6  |

All dimensions are in mm.

TAPE AND REEL SHIPMENT (suffix "13TR")

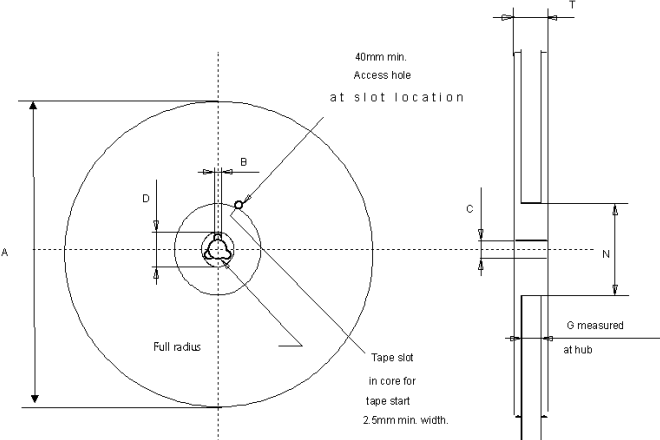

|                 |      |
|-----------------|------|
| Base Q.ty       | 2500 |
| Bulk Q.ty       | 2500 |
| A (max)         | 330  |
| B (min)         | 1.5  |
| C ( $\pm 0.2$ ) | 13   |
| F               | 20.2 |
| G (+ 2 / -0)    | 16.4 |
| N (min)         | 60   |
| T (max)         | 22.4 |

All dimensions are in mm.

TAPE DIMENSIONS

According to Electronic Industries Association (EIA) Standard 481 rev. A, Feb 1986

|                   |                    |     |
|-------------------|--------------------|-----|
| Tape width        | W                  | 16  |
| Tape Hole Spacing | P0 ( $\pm 0.1$ )   | 4   |
| Component Spacing | P                  | 8   |
| Hole Diameter     | D ( $\pm 0.1/-0$ ) | 1.5 |
| Hole Diameter     | D1 (min)           | 1.5 |
| Hole Position     | F ( $\pm 0.05$ )   | 7.5 |
| Compartment Depth | K (max)            | 6.5 |
| Hole Spacing      | P1 ( $\pm 0.1$ )   | 2   |

All dimensions are in mm.

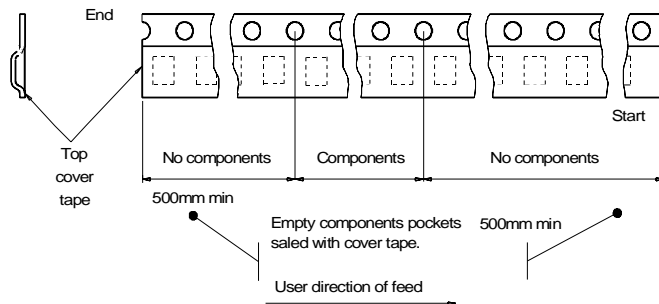
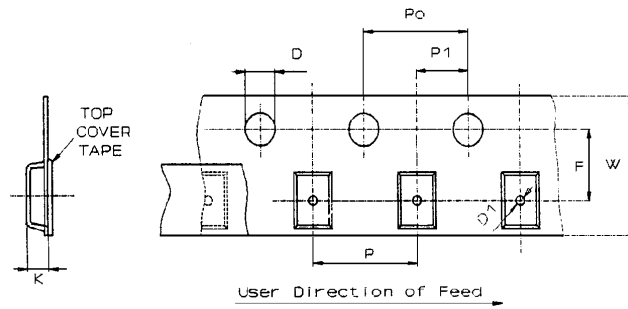
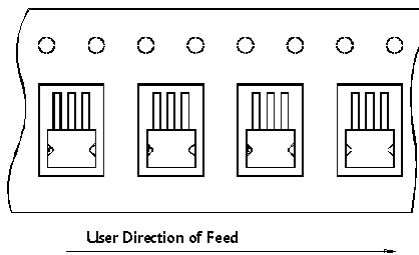

Information furnished is believed to be accurate and reliable. However, STMicroelectronics assumes no responsibility for the consequences of use of such information nor for any infringement of patents or other rights of third parties which may result from its use. No license is granted by implication or otherwise under any patent or patent rights of STMicroelectronics. Specifications mentioned in this publication are subject to change without notice. This publication supersedes and replaces all information previously supplied. STMicroelectronics products are not authorized for use as critical components in life support devices or systems without express written approval of STMicroelectronics.  
The ST logo is a trademark of STMicroelectronics

© 2003 STMicroelectronics - Printed in ITALY- All Rights Reserved.



STMicroelectronics GROUP OF COMPANIES

Australia - Brazil - Canada - China - Finland - France - Germany - Hong Kong - India - Israel - Italy - Japan - Malaysia -  
Malta - Morocco - Singapore - Spain - Sweden - Switzerland - United Kingdom - U.S.A.

<http://www.st.com>

## Looking for pricing, stock, or lifecycle information?

Click below to explore more details on WIN SOURCE:

-  [View VN820 on WIN SOURCE](#)
-  [STMicroelectronics](#) Information

## Optimize Your Supply Chain with WIN SOURCE Solutions

-  Global Sourcing Solution
-  Obsolete Management
-  Cost Control Management
-  Shortage Management
-  Alternative Solution
-  Excess Inventory Management