

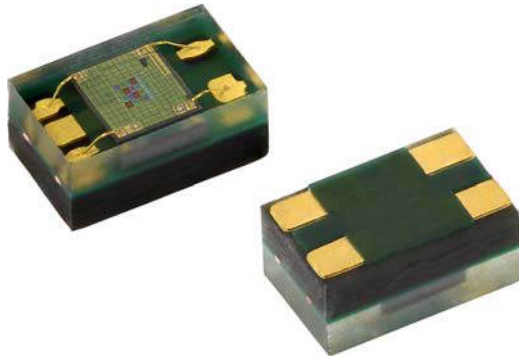

**THE DATASHEET OF
VEML6040A30G**



RGBW Color Sensor with I²C Interface



DESCRIPTION

VEML6040 color sensor senses red, green, blue, and white light and incorporates photodiodes, amplifiers, and analog / digital circuits into a single chip using CMOS process. With the color sensor applied, the brightness, and color temperature of backlight can be adjusted base on ambient light source that makes panel looks more comfortable for end user's eyes. VEML6040's adoption of Filtron™ technology achieves the closest ambient light spectral sensitivity to real human eye responses.

VEML6040 provides excellent temperature compensation capability for keeping the output stable under changing temperature. VEML6040's function are easily operated via the simple command format of I²C (SMBus compatible) interface protocol. VEML6040's operating voltage ranges from 2.5 V to 3.6 V. VEML6040 is packaged in a lead (Pb)-free 4 pin OPLGA package which offers the best market-proven reliability.

FEATURES

- Package type: surface mount
- Dimensions (L x W x H in mm): 2.0 x 1.25 x 1.0
- Integrated modules: color sensor (RGBW) and signal conditioning IC
- Filtron™ technology provides a spectrum matching real human eye responses
- Supports low transmittance (dark) lens design
- Fluorescent light flicker immunity
- Provides 16-bit resolution for each channel (R, G, B, W)
- Selectable maximum detection range (515.4, 1031, 2062, 4124, 8248, or 16 496) lux with highest sensitivity 0.007865 lux/step
- Package: OPLGA
- Temperature compensation: -40 °C to +85 °C
- Low power consumption I²C (SMBus compatible) interface
- Floor life: 168 h, MSL 3, according to J-STD-020
- Output type: I²C bus
- Operation voltage: 2.5 V to 3.6 V
- Material categorization: for definitions of compliance please see www.vishay.com/doc?99912



APPLICATIONS

- Handheld device
- Notebook
- Consumer device
- Industrial and mechanical application

PRODUCT SUMMARY					
PART NUMBER	OPERATING VOLTAGE RANGE (V)	I ² C BUS VOLTAGE RANGE (V)	PEAK SENSITIVITY (nm)	RANGE OF SPECTRAL BANDWIDTH λ _{0.5} (nm)	OUTPUT CODE
VEML6040	2.5 to 3.6	1.7 to 3.6	650, 550, 450 (R, G, B)	± 35, ± 35, ± 40 (R, G, B)	16 bit, I ² C

Note

(1) Adjustable through I²C interface

ORDERING INFORMATION			
ORDERING CODE	PACKAGING	VOLUME (1)	REMARKS
VEML6040A3OG	Tape and reel	MOQ: 2500 pcs	2.0 mm x 1.25 mm x 1.0 mm

Note

(1) MOQ: minimum order quantity



ABSOLUTE MAXIMUM RATINGS (T _{amb} = 25 °C, unless otherwise specified)					
PARAMETER	TEST CONDITION	SYMBOL	MIN.	MAX.	UNIT
Supply voltage		V _{DD}	0	3.6	V
Operation temperature range		T _{amb}	-40	+85	°C
Storage temperature range		T _{stg}	-40	+85	°C

RECOMMENDED OPERATING CONDITIONS (T _{amb} = 25 °C, unless otherwise specified)					
PARAMETER	TEST CONDITION	SYMBOL	MIN.	MAX.	UNIT
Supply voltage		V _{DD}	2.5	3.6	V
Operation temperature range		T _{amb}	-40	+85	°C
I ² C bus operating frequency		f _(I2CCLK)	10	400	kHz

PIN DESCRIPTIONS			
PIN ASSIGNMENT	SYMBOL	TYPE	FUNCTION
1	GND	I	Ground
2	SDAT	I / O (open drain)	I ² C data bus data input / output
3	SCLK	I	I ² C digital bus clock input
4	V _{DD}	I	Power supply input

BLOCK DIAGRAM

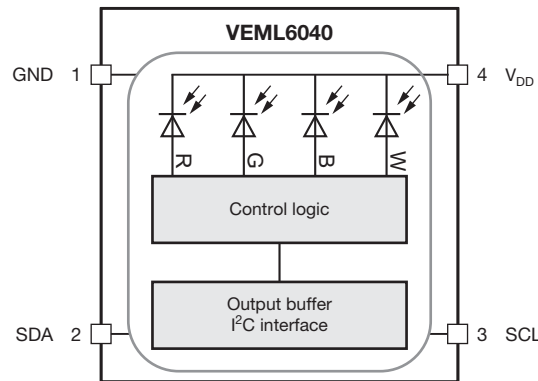

BASIC CHARACTERISTICS ($T_{amb} = 25\text{ }^{\circ}\text{C}$, unless otherwise specified)							
PARAMETER	TEST CONDITION	SYMBOL	MIN.	TYP.	MAX.	UNIT	
Supply voltage		V_{DD}	2.5	-	3.6	V	
Supply current		I_{DD}	-	200	-	μA	
I ² C signal input	Logic high	$V_{DD} = 3.3\text{ V}$	V_{IH}	1.5	-	-	V
	Logic low		V_{IL}	-	-	0.8	
	Logic high	$V_{DD} = 2.6\text{ V}$	V_{IH}	1.4	-	-	V
	Logic low		V_{IL}	-	-	0.6	
Peak sensitivity wavelength		λ_{PR}	-	650	-	nm	
		λ_{PG}	-	550	-	nm	
		λ_{PB}	-	450	-	nm	
Irradiance responsivity	$\lambda_{PR} = 619\text{ nm}^{(3)}$		-	96	-	counts/ $(\mu\text{W}/\text{cm}^2)$	
	$\lambda_{PG} = 518\text{ nm}^{(3)}$		-	74	-		
	$\lambda_{PB} = 467\text{ nm}^{(3)}$		-	56	-		
Detectable intensity	Minimum	G channel, $I_T = 1280\text{ ms}^{(1)(2)}$	-	0.007865	-	lx	
	Maximum	G channel, $I_T = 40\text{ ms}^{(1)(2)}$	-	16 496	-		
Dark offset		G channel, $I_T = 80\text{ ms}^{(1)}$	0	-	3		
Operating temperature range		T_{amb}	-40	-	+85	$^{\circ}\text{C}$	
Shutdown current	Light condition = dark, $V_{DD} = 3.6\text{ V}$	I_{DD}	-	800	-	nA	

Notes

- (1) Test condition: $V_{DD} = 3.3\text{ V}$, temperature: $25\text{ }^{\circ}\text{C}$
 (2) Light source: white LED
 (3) LED spectrum given in fig. 1; $I_T = 160\text{ ms}$

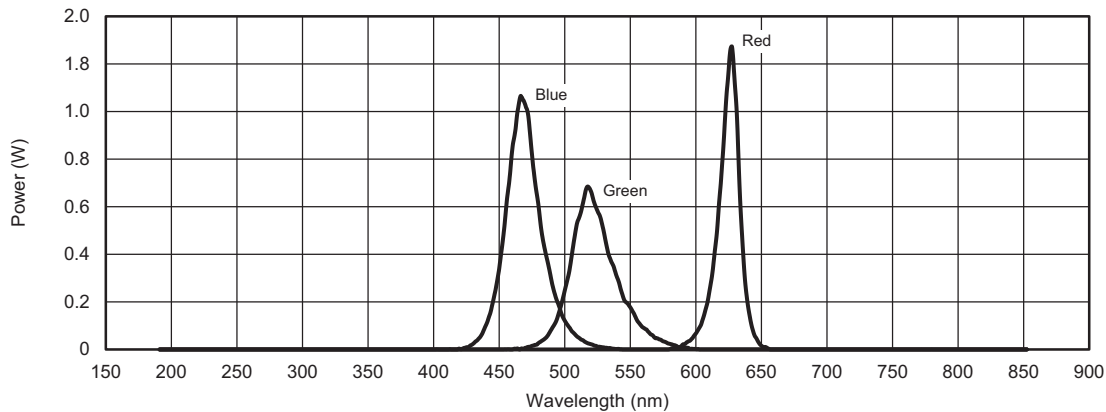
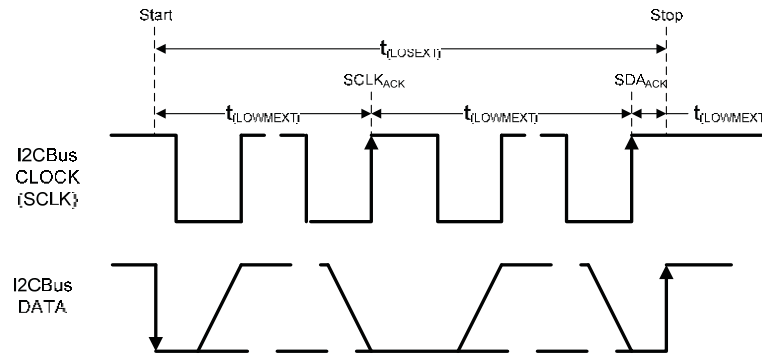
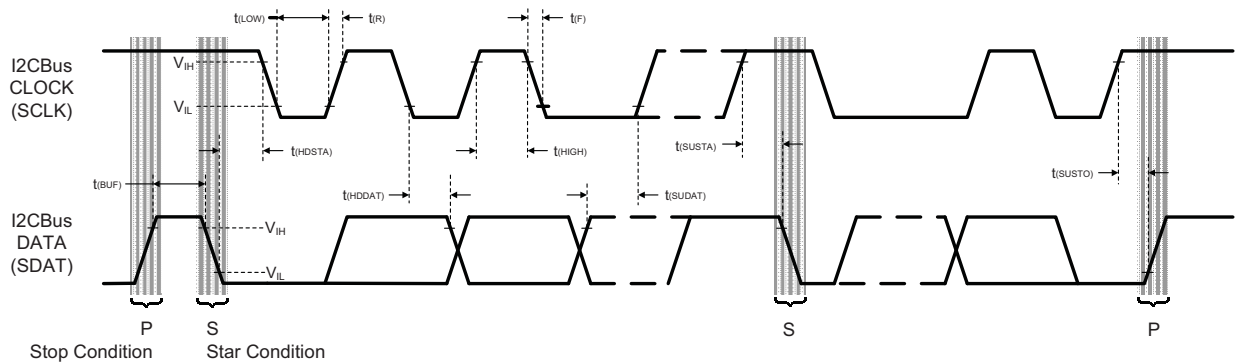

Fig. 1 - Normalized Spectral Response of Used LEDs for Measuring the Irradiance Responsivity

I²C BUS TIMING CHARACTERISTICS ($T_{amb} = 25\text{ }^{\circ}\text{C}$, unless otherwise specified)						
PARAMETER	SYMBOL	STANDARD MODE		FAST MODE		UNIT
		MIN.	MAX.	MIN.	MAX.	
Clock frequency	$f_{(SMBCLK)}$	10	100	10	400	kHz
Bus free time between start and stop condition	$t_{(BUF)}$	4.7	-	1.3	-	μs
Hold time after (repeated) start condition; after this period, the first clock is generated	$t_{(HDSTA)}$	4.0	-	0.6	-	μs
Repeated start condition setup time	$t_{(SUSTA)}$	4.7	-	0.6	-	μs
Stop condition setup time	$t_{(SUSTO)}$	4.0	-	0.6	-	μs
Data hold time	$t_{(HDDAT)}$	300	-	90	-	ns
Data setup time	$t_{(SUDAT)}$	250	-	100	-	ns
I ² C clock (SCK) low period	$t_{(LOW)}$	4.7	-	1.3	-	μs
I ² C clock (SCK) high period	$t_{(HIGH)}$	4.0	-	0.6	-	μs
Detect clock / data low timeout	$t_{(TIMEOUT)}$	25	35	-	-	ms
Clock / data fall time	$t_{(F)}$	-	300	-	300	ns
Clock / data rise time	$t_{(R)}$	-	1000	-	300	ns

 Fig. 2 - I²C Bus Timing Diagram

PARAMETER TIMING INFORMATION

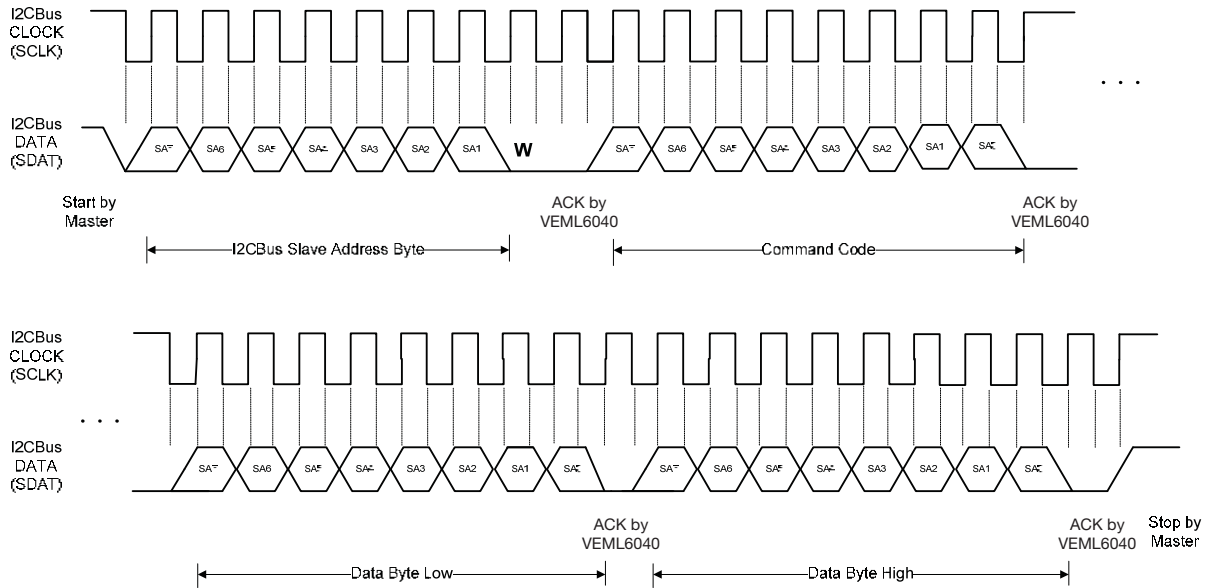

Fig. 3 - I²C Bus Timing for Sending Word Command Format

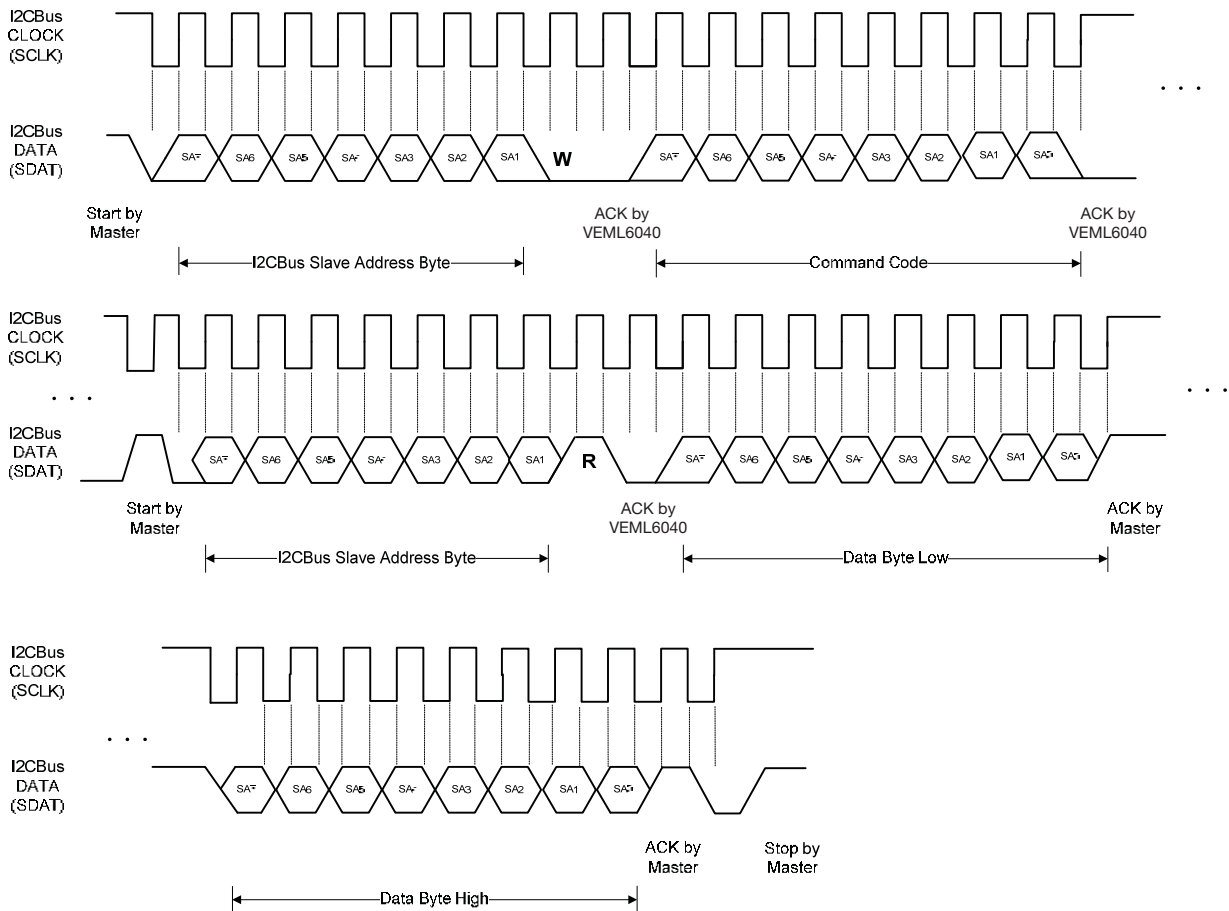

Fig. 4 - I²C Bus Timing for Receiving Word Command Format

TYPICAL PERFORMANCE CHARACTERISTICS ($T_{amb} = 25\text{ }^{\circ}\text{C}$, unless otherwise specified)

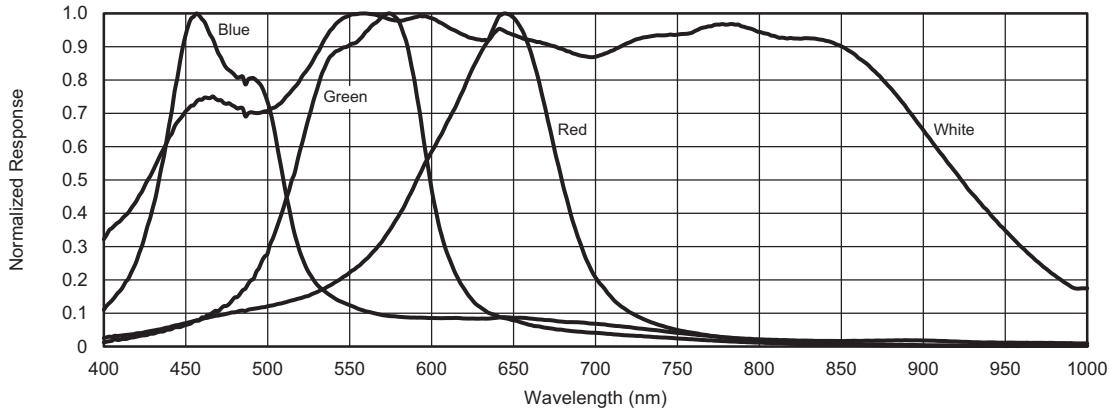

Fig. 5 - Normalized Spectral Response

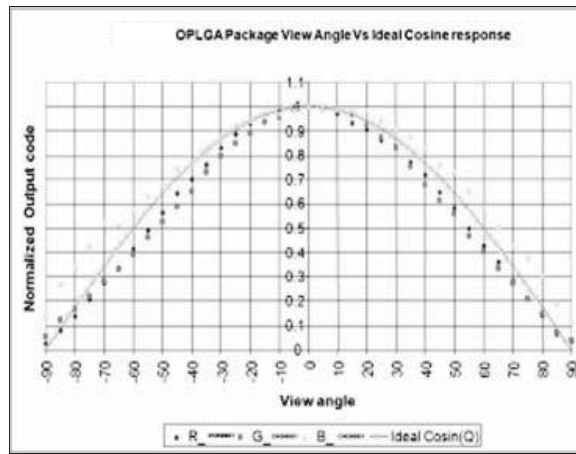

Fig. 6 - Normalized Output vs. View Angle

APPLICATION INFORMATION

Pin Connection with the Host

VEML6040 integrates R, G, B, and W sensor together with I²C interface. It is very easy for the baseband (CPU) to access VEML6040 output data via I²C interface without extra software algorithms. The hardware schematic is shown in the following diagram.

The 0.1 μF capacitor near the V_{DD} pin is used for power supply noise rejection. The 2.2 k Ω s are suitable for the pull-up resistors of I²C.

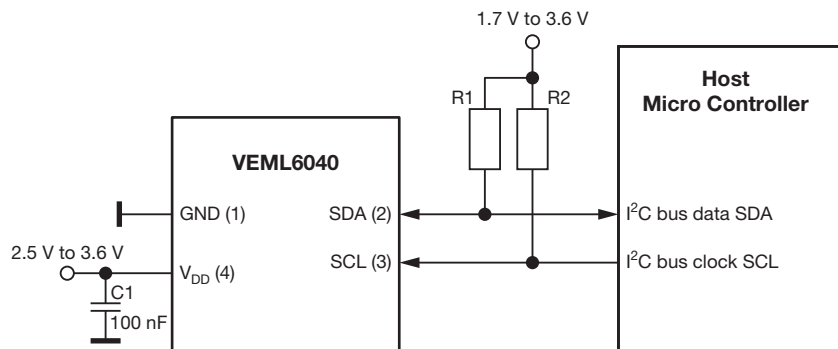

Fig. 7 - Hardware Pin Connection Diagram



Digital Interface

The VEML6040 contains a CONF register (00h) used for operation control and parameter setup. Measurement results are stored in four separate registers, one each for red, green, blue, and white respectively (08h to 0Bh). All registers are accessible via I2C communication. Figure 8 shows the basic I2C communication with the VEML6040. Each of the registers in the VEML6040 are 16 bit wide, so 16 bit should be written when a write command is sent, and 16 bit should be read when a read command is sent. The built in I2C interface is compatible with I2C modes "standard" and "fast": 100 kHz to 400 kHz

Send Word → Write Command to VEML6040



Receive Word → Read Data from VEML6040

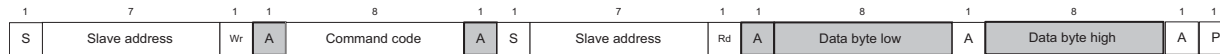

S = start condition
P = stop condition
A = acknowledge
Shaded area = VEML6040 acknowledge

Fig. 8 - Command Protocol Format

Note

- Please note the repeat start condition when data is read from the sensor. A stop condition should not be sent here.

Slave Address and Function Description

VEML6040 uses 10h slave address for 7-bit I2C addressing protocol. VEML6040 has 16-bit resolution for each channel (R, G, B, and W) that provides sensitivity up to 0.0056 lux/step for G, which is advantageous under a low transmittance lens design (dark lens).

TABLE 1 - SLAVE ADDRESS AND COMMAND CODE DESCRIPTION
SLAVE ADDRESS 0x10
Table with columns: COMMAND CODE, DATE BYTE LOW / HIGH, REGISTER NAME, R / W, BIT (7, 6, 5, 4, 3, 2, 1, 0)

Note

- Slave address is 7-bit addressing protocol



Configuration Register Format

VEML6040 has a 16-bit configuration register for controlling. The description of each command format is shown in the following tables.

TABLE 2-1 - COMMAND CODE 00H BITS DESCRIPTION							
SLAVE ADDRESS: 0x10; REGISTER NAME: CONF; COMMAND CODE: 00H / DATA BYTE LOW							
X	IT			X	TRIG	AF	SD
BIT 7	BIT 6	BIT 5	BIT 4	BIT 3	BIT 2	BIT 1	BIT 0
0	IT2	IT1	IT0	0	TRIG	AF	SD
DESCRIPTION							
IT		Integration time setting					
TRIG		Proceed one detecting cycle at manual force mode					
AF		Auto / manual force mode					
SD		Chip shutdown setting					

TABLE 2-2 - COMMAND CODE 00H REGISTER SETTING			
BITS SETTING		DESCRIPTION	
BIT 7		Default = 0	
BIT 6, 5, 4 IT (2 : 0)		(0 : 0 : 0) = 40 ms	
		(0 : 0 : 1) = 80 ms	
		(0 : 1 : 0) = 160 ms	
		(0 : 1 : 1) = 320 ms	
		(1 : 0 : 0) = 640 ms	
		(1 : 0 : 1) = 1280 ms	
		BIT 3	
		Default = 0	
		BIT 2 TRIG	
		0 = no trigger	
		1 = trigger one time detect cycle	
		BIT 1 AF	
		0 = auto mode	
		1 = force mode	
		BIT 0 SD	
		0 = enable color sensor	
		1 = disable color sensor	

TABLE 3-1 - RESERVE COMMAND CODE DESCRIPTION		
RESERVED		COMMAND CODE: 00H / DATA BYTE HIGH
Command	Bit	Description
Reserved	7 : 0	Default = 0x00

TABLE 3-2 - RESERVE COMMAND CODE DESCRIPTION		
RESERVED		COMMAND CODE: 01H TO 07H
Command	Bit	Description
Reserved	7 : 0	Default = 0x00

TABLE 4 - READ OUT COMMAND CODE DESCRIPTION			
REGISTER	COMMAND CODE	BIT	DESCRIPTION
R_DATA	0x08_L (08H data byte low)	7 : 0	0x00 to 0xFF, R channel LSB output data
	0x08_H (08H data byte high)	7 : 0	0x00 to 0xFF, R channel MSB output data
G_DATA	0x09_L (09H data byte low)	7 : 0	0x00 to 0xFF, G channel LSB output data
	0x09_H (09H data byte high)	7 : 0	0x00 to 0xFF, G channel MSB output data
B_DATA	0x0A_L (0AH data byte low)	7 : 0	0x00 to 0xFF, B channel LSB output data
	0x0A_H (0AH data byte high)	7 : 0	0x00 to 0xFF, B channel MSB output data
W_DATA	0x0B_L (0BH data byte low)	7 : 0	0x00 to 0xFF, W channel LSB output data
	0x0B_H (0BH data byte high)	7 : 0	0x00 to 0xFF, W channel MSB output data

RECOMMENDED INFRARED REFLOW

Soldering conditions which are based on J-STD-020 C

IR REFLOW PROFILE CONDITION			
PARAMETER	CONDITIONS	TEMPERATURE	TIME
Peak temperature		255 °C + 0 °C / - 5 °C (max.: 260 °C)	10 s
Preheat temperature range and timing		150 °C to 200 °C	60 s to 180 s
Timing within 5 °C to peak temperature		-	10 s to 30 s
Timing maintained above temperature / time		217 °C	60 s to 150 s
Timing from 25 °C to peak temperature		-	8 min (max.)
Ramp-up rate		3 °C/s (max.)	-
Ramp-down rate		6 °C/s (max.)	-

Recommend Normal Solder Reflow is 235 °C to 255 °C

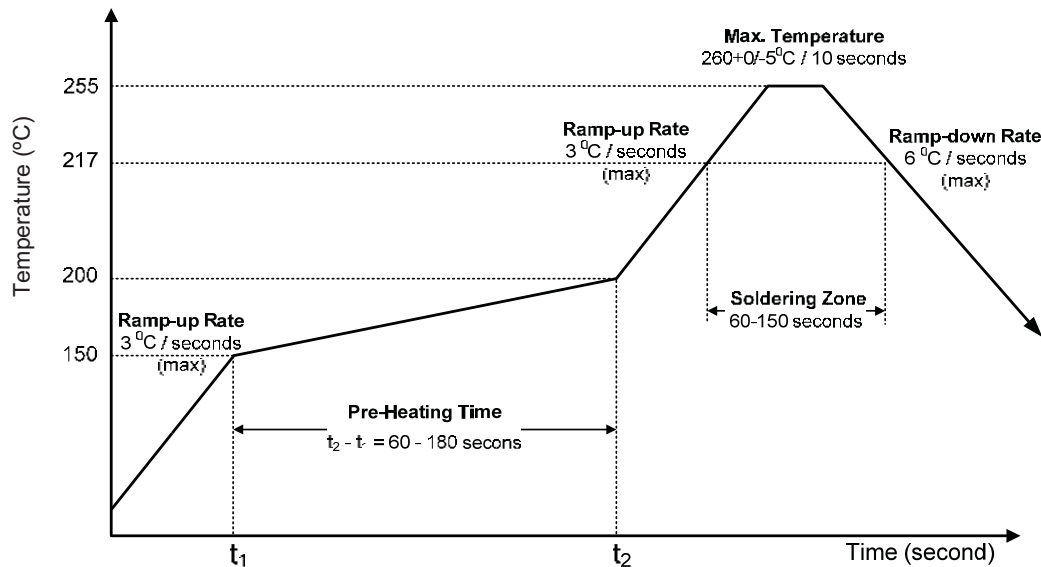

Fig. 11 - VEML6040 OPLGA Solder Reflow Profile Chart

RECOMMENDED IRON TIP SOLDERING CONDITION AND WARNING HANDLING

1. Solder the device with the following conditions:
 - 1.1. Soldering temperature: 400 °C (max.)
 - 1.2. Soldering time: 3 s (max.)
2. If the temperature of the method portion rises in addition to the residual stress between the leads, the possibility that an open or short circuit occurs due to the deformation or destruction of the resin increases.
3. The following methods: VPS and wave soldering, have not been suggested for the component assembly.
4. Cleaning method conditions:
 - 4.1. Solvent: methyl alcohol, ethyl alcohol, isopropyl alcohol
 - 4.2. Solvent temperature < 45 °C (max.)
 - 4.3. Time: 3 min (min.)



Disclaimer

ALL PRODUCT, PRODUCT SPECIFICATIONS AND DATA ARE SUBJECT TO CHANGE WITHOUT NOTICE TO IMPROVE RELIABILITY, FUNCTION OR DESIGN OR OTHERWISE.

Vishay Intertechnology, Inc., its affiliates, agents, and employees, and all persons acting on its or their behalf (collectively, "Vishay"), disclaim any and all liability for any errors, inaccuracies or incompleteness contained in any datasheet or in any other disclosure relating to any product.

Vishay makes no warranty, representation or guarantee regarding the suitability of the products for any particular purpose or the continuing production of any product. To the maximum extent permitted by applicable law, Vishay disclaims (i) any and all liability arising out of the application or use of any product, (ii) any and all liability, including without limitation special, consequential or incidental damages, and (iii) any and all implied warranties, including warranties of fitness for particular purpose, non-infringement and merchantability.

Statements regarding the suitability of products for certain types of applications are based on Vishay's knowledge of typical requirements that are often placed on Vishay products in generic applications. Such statements are not binding statements about the suitability of products for a particular application. It is the customer's responsibility to validate that a particular product with the properties described in the product specification is suitable for use in a particular application. Parameters provided in datasheets and / or specifications may vary in different applications and performance may vary over time. All operating parameters, including typical parameters, must be validated for each customer application by the customer's technical experts. Product specifications do not expand or otherwise modify Vishay's terms and conditions of purchase, including but not limited to the warranty expressed therein.

Hyperlinks included in this datasheet may direct users to third-party websites. These links are provided as a convenience and for informational purposes only. Inclusion of these hyperlinks does not constitute an endorsement or an approval by Vishay of any of the products, services or opinions of the corporation, organization or individual associated with the third-party website. Vishay disclaims any and all liability and bears no responsibility for the accuracy, legality or content of the third-party website or for that of subsequent links.

Except as expressly indicated in writing, Vishay products are not designed for use in medical, life-saving, or life-sustaining applications or for any other application in which the failure of the Vishay product could result in personal injury or death. Customers using or selling Vishay products not expressly indicated for use in such applications do so at their own risk. Please contact authorized Vishay personnel to obtain written terms and conditions regarding products designed for such applications.

No license, express or implied, by estoppel or otherwise, to any intellectual property rights is granted by this document or by any conduct of Vishay. Product names and markings noted herein may be trademarks of their respective owners.

Looking for pricing, stock, or lifecycle information?

Click below to explore more details on WIN SOURCE:

 [View VEMML6040A3OG on WIN SOURCE](#)

 [Vishay Information](#)

Optimize Your Supply Chain with WIN SOURCE Solutions

-  Global Sourcing Solution
-  Obsolete Management
-  Cost Control Management
-  Shortage Management
-  Alternative Solution
-  Excess Inventory Management