



**THE DATASHEET OF
TP3410J304-X**



TP3410 ISDN Basic Access Echo-Cancelling 2B1Q U Transceiver

General Description

The TP3410 is a complete monolithic transceiver for ISDN Basic Access data transmission at either end of the U interface. Fully compatible with ANSI specification T1.601, it is built on National's advanced double-metal CMOS process, and requires only a single +5V power supply. A total of 160 kbps full-duplex transmission on a single twisted-pair is provided, with user-accessible channels including 2 'B' channels, each at 64 kbps, 1 'D' channel at 16 kbps, and an additional 4 kbps for loop maintenance. 12 kbps of bandwidth is reserved for framing. 2B1Q Line coding is used, in which pairs of binary bits are coded into 1 of 4 quantum levels for transmission at 80k symbols/sec (hence 2 Binary/1 Quaternary). To meet the very demanding specifications for < 1 in 10e7 Bit Error Rate even on long loops with crosstalk, the device includes 2 Adaptive Digital Signal Processors, 2 Digital Phase-locked Loops and a controller for automatic activation.

The digital interface on the device can be programmed for compatibility with either of two types of control interface for chip control and access to all spare bits. In one mode a Microwire serial control interface is used together with a 2B + D digital interface which is compatible with the Time-division Multiplexed format of PCM Combo devices and backplanes. This mode allows independent time-slot assignment for the 2 B channels and the D channel.

Alternatively, the GCI (General Circuit Interface) may be selected, in which the 2B + D data is multiplexed together with control, spare bits and loop maintenance data on 4 pins.

Features

- 2 'B' + 'D' channel 160 kbps transceiver for LT and NT
- Meets ANSI T1.601 U.S. Standard
- 2B1Q line coding with scrambler/descrambler
- Range exceeds 18 kft of #26 AWG
- > 70 dB adaptive echo-cancellation and equalization
- On-chip timing recovery, no precision external components
- Direct connection to small line transformer
- Automatic activation controller
- Selectable digital interface formats:
 - TDM with time-slot assigner up to 64 slots, plus MICROWIRE™ control interface
 - GCI (General Circuit Interface), or
 - IDL (Inter-chip Digital Link)
- Backplane clock DPLL allows free-running XTAL
- Elastic data buffers meet Q.502 wander/jitter for Slave-slave mode on PBX Trunk Cards and DLC
- EOC and spare bits access with automatic validation
- Block error counter
- 6 loopback test modes
- Single +5V supply, 325 mW active power
- 20 mW idle mode with line signal "wake-up" detector

Applications

- LT, NT-1, NT-2 Trunks, U-TE's, Regenerators etc.
- Digital Loop Carrier
- POTS Pair-Gain Systems
- Easy Interface to:
 - Line Card Backplanes
 - "S" Interface Device
 - Codec/Filter Combos
 - LAPD Processor
 - HDLC Controller

TP3420A
TP3054/7 and TP3075/6
MC68302, HPC16400
TP3451

Combo® and TRI-STATE® are registered trademarks of National Semiconductor Corporation. MICROWIRE™ is a trademark of National Semiconductor Corporation. The General Circuit Interface (G.C.I.) is an interface specification of the Group-of-Four European Telecommunications Companies.

TP3410 ISDN Basic Access Echo-Cancelling U Transceiver

Block Diagram

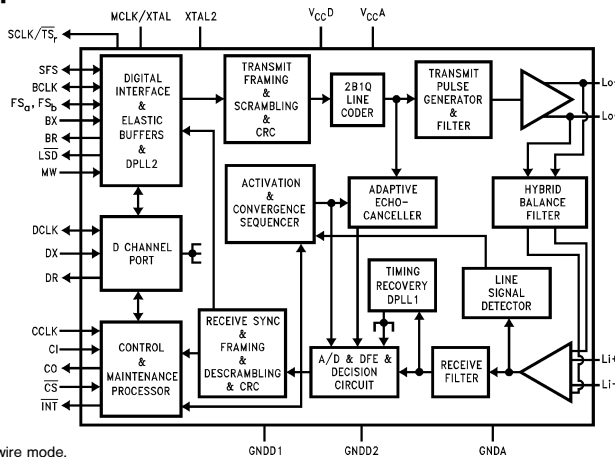

Note: Pin names show Microwire mode.

TL/H/9151-1

Connection Diagrams

Pin Names for MICROWIRE Mode

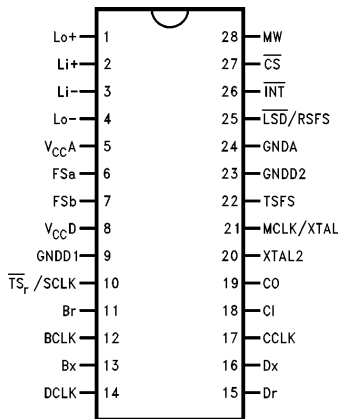

Top View

TL/H/9151-2

Pin Names for GCI Mode

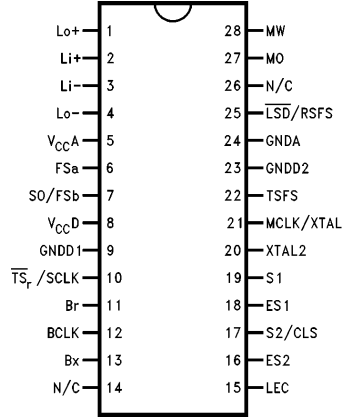

Top View

TL/H/9151-3

Order Number TP3410J
See NS Package Number J28A

Pin Descriptions

Pin No.	Symbol	Description
24	GNDA	Negative power supply pins, which must be connected together close to the device. All digital signals are referenced to these pins, which are normally at the system 0V (Ground) potential.
9	GNDD1	
23	GNDD2	
5	V _{CC} A	Positive power supply input for the analog sections, which must be +5V ±5% and must be directly connected to V _{CC} D.
8	V _{CC} D	Positive power supply input for the digital section, which must be +5V ±5% and must be directly connected to V _{CC} A.
21	MCLK/ XTAL	The 15.36 MHz Master Clock input, which requires either a parallel resonance crystal to be tied between this pin and XTAL2, or a CMOS logic level clock input from a stable source (a TTL Logic "1" level is not suitable). This clock does not need to be synchronized to the system clock (BCLK and FS), see Section 5.1.
20	XTAL2	The output of the crystal oscillator, which should be connected to one end of the crystal, if used; otherwise this pin must be left open-circuit. Not recommended to drive additional logic.
10	TSr/ SCLK	This pin has 2 functions: in LT mode it is an open-drain n-channel TSr output, which goes low only during the time-slots assigned to the B1 and B2 channels at the Br pin in order to enable the TRI-STATE control of the backplane line-driver. In NT mode it is a full CMOS 15.36 MHz synchronous clock output which is frequency-locked to the received line signal (unlike the XTAL pins it is not free-running).

Pin No.	Symbol	Description
22	TSFS	The Transmit Superframe Sync pin, which indicates the start of each 12 ms transmit superframe at the U Interface. In NT mode this pin is always an output. In LT mode it may be selected to be either an input or CMOS output via Register CR2; when selected as an output the signal is a square-wave. Must be tied low if selected as input yet not driven.
25	LSD/RSFS	This pin is an open-drain n-channel Line Signal Detector output, which is normally high-impedance and pulls low only when the device is powered down and an incoming wake-up signal is detected from the far-end. As an option this pin can be programmed to be an output indicating the start of the received superframe at the U interface; an external pull-up resistor is required. The RSFS signal indicates the start of each 12 ms receive superframe from the U Interface and is available in NT and LT modes. The Received Superframe Synch clock output is accessible on pin 25 by writing X'1C04 and X'100C (or X'100E) during device initialization. See TP3410 users manual AN-913, Part II Section 4.18).
1	Lo+	Transmit 2B1Q signal differential outputs to the line transformer. When used with an appropriate 1:1.5 step-up transformer and the line coupling circuit recommended in the Applications section, the line signal conforms to the output specifications in the ANSI standard.
4	Lo-	

Pin Descriptions (Continued)

PIN DESCRIPTIONS SPECIFIC TO MICROWIRE MODE ONLY (MW = 1)

Pin No.	Symbol	Description
2	Li+	Receive 2B1Q signal differential inputs from the line transformer. For normal full-duplex operation, these pins should be connected to the Lo± pins through the recommended coupling circuit, as shown in the Applications section.
3	Li-	
28	MW	The Microwire/ $\overline{\text{GCI}}$ Select pin, which must be tied to V _{CCD} to enable the Microwire Interface with any of the data formats at the Digital System Interface.
12	BCLK	The Bit Clock pin, which determines the data shift rate for 'B' and 'D' channel data on the digital interface side of the device. When Digital System Interface (DSI) Slave mode is selected (see Digital Interfaces section), BCLK is an input which may be any multiple of 8 kHz from 256 kHz to 4.096 MHz. It need not be synchronous with MCLK. When DSI Master mode is selected, this pin is a CMOS output clock at 256 kHz, 512 kHz, 1.536 MHz, 2.048 MHz or 2.56 MHz, depending on the selection in Command Register 1. It is synchronous with the data on Bx and Br.
6	FSa	In DSI Slave mode, this pin is the Transmit Frame Sync pulse input, requiring a positive edge to indicate the start of the active channel time for transmit B1 channel data into Bx. In DSI Master mode, this pin is a Frame Sync CMOS output pulse conforming with the selected Digital Interface format.
7	FSb	In DSI Slave mode, this pin is the Receive Frame Sync pulse input, requiring a positive edge to indicate the start of the active channel time of the device for receive B channel data out from Br (see DSI Format section). In DSI Master mode this pin is a Frame Sync CMOS output pulse conforming with the selected Digital Interface format.
13	Bx	The digital input for B and, if selected, D channel data to be transmitted to the line; must be synchronous with BCLK.
11	Br	The TRI-STATE output for B and, if selected, D channel data received from the line; it is synchronous with BCLK.
18	CI	The Microwire control channel data input.
19	CO	The Microwire control channel TRI-STATE output for status information. When not enabled by $\overline{\text{CS}}$, this output is high-impedance.

*Crystal specifications: 15.36 MHz ±50 ppm parallel resonant; R_S < 20Ω. Load with 33 pF to GND each side (+7 pF due to pin capacitance).

Pin No.	Symbol	Description
17	CCLK	The Microwire control channel Clock input, which may be asynchronous with BCLK.
27	$\overline{\text{CS}}$	The Chip Select input, which enables the Control channel data to be shifted in and out when pulled low. When high, this pin inhibits the Control interface.
26	$\overline{\text{INT}}$	The Interrupt output, a latched open-drain output signal which is normally high-impedance, and goes low to indicate a change of status of the loop transmission system. This latch is cleared when the Status Register is read by the microprocessor.
16	Dx	When the D-port is enabled this pin is the digital input for D channel data to be transmitted to the line clocked by DCLK or BCLK, see Register CR2. When the D-port is disabled via CR2, this pin must be tied to GND.
15	Dr	When the D-port is enabled this pin is the TRI-STATE output for D channel data to be received from the line clocked by DCLK or BCLK, see Register CR2.
14	DCLK	When the D-port is enabled, in DSI Slave or Master mode, this is a 16 kHz clock CMOS output for D channel data. When the D-port is disabled or not used, this pin must be left open-circuit.

PIN DESCRIPTIONS SPECIFIC TO GCI MODE ONLY (MW = 0)

Pin No.	Symbol	Description
28	MW	The Microwire/ $\overline{\text{GCI}}$ select input, which must be tied to GND to enable the GCI mode at the Digital System Interface.
27	MO	The GCI Master/Slave select input for the clock direction. Connect this pin low to select BCLK and FSa as inputs i.e., GCI Slave; Selection of LT or NT mode must be made in register CR2. When MO is connected high, NT Mode is automatically selected, and BCLK, FSa and FSb are outputs, i.e., the GCI Master, see Section 8.
12	BCLK	The Bit Clock pin, which controls the shifting of data on the Bx and Br pins, at a rate of 2 BCLK cycles per data bit. When GCI Slave mode is selected (see Digital Interfaces section), BCLK is an input which may be any multiple of 16 kHz from 512 kHz to 6.144 MHz. It need not be synchronous with MCLK. When GCI Master mode is selected, this pin is a CMOS output clock at 512 kHz or 1.536 MHz, depending on the connection of the S2/CLS pin. It is synchronous with the data on Bx and Br.

Pin Descriptions (Continued)

Pin No.	Symbol	Description	Pin No.	Symbol	Description
13	Bx	The digital input for multiplexed B, D and control data clocked by BCLK at the rate of 1 data bit per 2 BCLK cycles, and 32 data bits per 8 kHz frame defined by FSa.	17	S2/CLS	In GCI Slave mode (MO = 0): input pins S2, S1 and S0 together provide a 3-bit binary-coded select port for the GCI channel number; S2 is the msb. These pins must be connected either to V _{CCD} or GND to select the 1-of-8 GCI slots which are available if BCLK ≥ 4.096 MHz is used. In GCI Master mode (MO = 1) S2/CLS is the GCI Clock Select input. Connect this pin high to select BCLK = 1.536 MHz; connect CLS low to select BCLK = 512 kHz. SO/FSb is a Frame Sync CMOS output pulse which identifies the B2 channel.
			19	S1	
			7	SO/FSb	
11	Br	The open-drain n-channel output for multiplexed B, D and control data clocked by BCLK at the rate of 1 data bit per 2 BCLK cycles, and 32 data bits per 8 kHz frame defined by FSa. A pull-up resistor is required to define the logical 1 state.			
6	FSa	In GCI Slave mode (MO connected low), this pin is the 8 kHz Frame Sync pulse input, requiring a positive edge to indicate the start of the GCI slot time for both transmit and receive data at Bx and Br. In GCI Master mode, this pin is the 8 kHz Frame Sync CMOS output pulse.	18	ES1	While in GCI mode, the ES1, ES2 pins are local input pins. The status of the pins can be accessed via the RXM56 register bits 5,6 corresponding to ES1, ES2.
			16	ES2	
			15	LEC	Latched External Control output, which is the output of a latched bit in the TXM56 Register.

Functional Description

1.1 Power-On Initialization

When power is first applied, power-on reset circuitry initializes the TP3410 and puts it into the power-down state, in which all the internal circuits including the Master oscillator are inactive and in a low power state except for the Line-Signal Detect circuit; the line outputs Lo+ /Lo- are in a high impedance state. All programmable registers and the Activation Sequence Controller are reset.

All states in the Command Registers initialize as shown in their respective code tables. The desired modes for all programmable functions may be selected by writing to these registers via the control channel (Microwire or Monitor channel, as appropriate). Microwire is functional regardless of whether the device is powered up or down, whereas the GCI channel requires the BCLK to be running.

1.2 Power-Up/Power-Down Control

Before powering up the device, the Configuration Registers should be programmed with the required modes.

In Microwire mode and GCI Slave mode, the device is powered up and the MCLK started by writing the PUP command, as described in the Activation section. In GCI Master mode, there are 2 methods of powering up the device: the Bx data input can be pulled low (local power-up command) or the 10 kHz wake-up tone may be received from the far-end.

The power-down state may be re-entered by writing a Power-down command. In the power-down state, all programmed register data is retained. Also, if the loop had been successfully activated and deactivated, the adaptive circuits are “frozen” and the coefficients in the Digital Signal Processors are stored to enable rapid reactivation (“warm-start”).

1.3 Reset

A software reset command is provided to enable the clearing of the Activation sequencer without disconnecting the power supply to the device, see the Activation section.

2.0 TRANSMISSION SECTION

2.1 Line Coding And Frame Format

For both directions of transmission, 2B1Q coding is used, as illustrated in *Figure 1*. This coding rule requires that binary data bits are grouped in pairs, and each pair is transmitted as a symbol, the magnitude of which may be 1 out of 4 equally spaced voltage levels (a “Quat”). There is no symbol value at 0V in this code, the relative quat magnitudes being ± 1 (the “inner” levels) and ± 3 (the “outer” levels). No redundancy is included in this code, and in the limit there is no bound to the RDS, although scrambling controls the RDS in a practical sense (RDS is the Running Digital Sum, which is the algebraic summation of all symbol values in a transmission session).

The frame format used in the TP3410 follows the ANSI standard, shown in Table I. Each complete frame consists of 120 quats, with a line bit rate of 80 kq/s, giving a frame duration of 1.5 ms. A 9 quat syncword defines the framing boundary. Furthermore, a “superframe” consisting of 8 frames is defined in order to provide sub-channels within the spare bits M1 to M6. Inversion of the syncword defines the superframe boundary. Prior to transmission, all data, with the exception of the syncword, is scrambled using a self-synchronizing scrambler to implement the specified 23rd-order polynomial. Descrambling is included in the receiver.

First Bit (Sign)	Second Bit (Magnitude)	Quat	Pulse Amplitude (Note 1)
1	0	+3	+2.5V
1	1	+1	+0.83V
0	1	-1	-0.83V
0	0	-3	-2.5V

Note 1: For isolated pulses into a 135 Ω termination with recommended transformer interface.

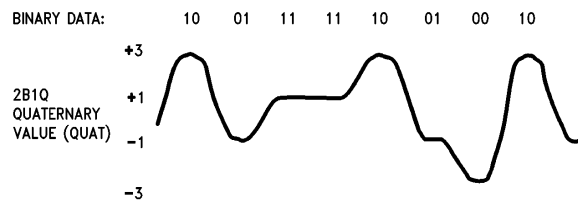

FIGURE 1. 2B1Q Line-Coding Rule

TL/H/9151-25

Functional Description (Continued)

Superframe #	Basic Frame #	Sync Word	12x(2B + D)	Overhead Bits (M ₁ –M ₆)								
				Quat Positions	1–9	10–117	118s	118m	119s	119m	120s	120m
				Bit Positions	1–18	19–234	235	236	237	238	239	240
Superframe #	Basic Frame #	Sync Word	2B + D	M ₁	M ₂	M ₃	M ₄	M ₅	M ₆			
1	1	ISW	2B + D	eoca ₁	eoca ₂	eoca ₃	act	1	1			
	2	SW	2B + D	eocd _m	eoci ₁	eoci ₂	dea	1	febe			
	3	SW	2B + D	eoci ₃	eoci ₄	eoci ₅	1	crc ₁	crc ₂			
	4	SW	2B + D	eoci ₆	eoci ₇	eoci ₈	1	crc ₃	crc ₄			
	5	SW	2B + D	eoca ₁	eoca ₂	eoca ₃	1	crc ₅	crc ₆			
	6	SW	2B + D	eocd _m	eoci ₁	eoci ₂	1	crc ₇	crc ₈			
	7	SW	2B + D	eoci ₃	eoci ₄	eoci ₅	uoa	crc ₉	crc ₁₀			
	8	SW	2B + D	eoci ₆	eoci ₇	eoci ₈	aib	crc ₁₁	crc ₁₂			
2, 3, ...	1	ISW										

(a) Network → NT

Superframe #	Basic Frame #	Sync Word	12x(2B + D)	Overhead Bits (M ₁ –M ₆)								
				Quat Positions	1–9	10–117	118s	118m	119s	119m	120s	120m
				Bit Positions	1–18	19–234	235	236	237	238	239	240
Superframe #	Basic Frame #	Sync Word	2B + D	M ₁	M ₂	M ₃	M ₄	M ₅	M ₆			
1	1	ISW	2B + D	eoca ₁	eoca ₂	eoca ₃	act	1	1			
	2	SW	2B + D	eoc _{dm}	eoci ₁	eoci ₂	ps ₁	1	febe			
	3	SW	2B + D	eoci ₃	eoci ₄	eoci ₅	ps ₂	crc ₁	crc ₂			
	4	SW	2B + D	eoci ₆	eoci ₇	eoci ₈	ntm	crc ₃	crc ₄			
	5	SW	2B + D	eoca ₁	eoca ₂	eoca ₃	cso	crc ₅	crc ₆			
	6	SW	2B + D	eoc _{dm}	eoci ₁	eoci ₂	1	crc ₇	crc ₈			
	7	SW	2B + D	eoci ₃	eoci ₄	eoci ₅	1	crc ₉	crc ₁₀			
	8	SW	2B + D	eoci ₆	eoci ₇	eoci ₈	1	crc ₁₁	crc ₁₂			
2, 3, ...	1	ISW										

(b) NT → Network

Note: 8 × 1.5 ms Basic Frames = 12 ms/Superframe. NT-to-Network superframe is offset from Network-to-NT superframe by 60 ± 2 quats (about 0.75 ms). All bits other than the Sync Word are scrambled.

Symbols & Abbreviations

act = start-up bit (= 1 during start-up)
aib = alarm indication bit (= 0 to indicate interruption)
crc = cyclic redundancy check: covers 2B + D + M₄
 1 = most significant bit
 2 = next significant bit etc.
cso = cold-start-only bit (= 1 to indicate cold-start-only)
dea = turn off bit (= 0 to announce turn off)
eoc = embedded operations channel
 a = address bits
 dm = data/message indicator (0 = data, 1 = message)
 i = information (data or message)
febe = far end block error bit (= 0 for errored superframe)

ntm = NT in test mode bit (= 0 to indicate test mode)
ps1, ps2 = power status bits (= 0 to indicate power problems)
Quat = pair of bits forming quaternary symbol
 s = sign bit (first in quat)
 m = magnitude bit (second in quat)
sai = S-activation-indication bit (= 1 for S/T activity)
uoa = U-only-activation bit (= 1 to activate S/T)
"1" = reserved bit for future standard (= 1)
"1*" = network indicator bit (= 1, reserved for network use)
2B + D = user data, bits 19–234 in frame
M = M-channel, bits 235–240 in frame
SW/ISW = synchronization word/inverted synchronization word, bits 1–18 in frame

TABLE I. 2B1Q Superframe Format and Overhead Bit Assignments

Functional Description (Continued)

2.2 Line Transmit Section

Data to be transmitted to the line consists of the customer's 2B+D channel data and the data from the maintenance processor, plus other "spare" bits in the overhead channels. This data is multiplexed and scrambled prior to addition of the syncword. A pulse waveform synthesizer then drives the transmit filter, which in turn passes the line signal to the line driver. The differential line-driver outputs, Lo+ and Lo-, are designed to drive a transformer through an external termination circuit. A 1:1.5 transformer, designed as shown in the Applications section, results in a signal amplitude of nominally 2.5V pk on the line for single quats of the outer (± 3) levels. Note, however, that because of the RDS accumulation of the 2B1Q line code, continuous random data will produce signal swings considerably greater than this on the line. Short-circuit protection is included in the output stage; overvoltage protection must be provided externally.

2.3 Line Receive Section

The receive input signal should be derived from the transformer by means of a coupling circuit as shown in the Applications section. At the front-end of the receive section is a continuous filter followed by a switched-capacitor low-pass filter, which limits the noise bandwidth. A Hybrid Balance Filter provides a degree of analog echo-cancellation in order to limit the dynamic range of the composite signal. An A/D converter then samples the composite received signal prior to the cancellation of the "echo" from the local transmitter by means of an adaptive digital transversal filter (i.e., the "echo-canceller"). Following this, the attenuation and distortion (inter-symbol interference) of the received signal from the far-end, caused by the transmission line, are equalized by a second adaptive digital filter configured as a Decision Feedback Equalizer (DFE), thereby restoring a "flat" channel response with maximum received eye opening over a wide spread of cable attenuation characteristics.

From the received line signal, a Timing Recovery circuit based on a DPLL (Digital Phase-Locked Loop) recovers a low-jitter clock for optimum sampling of the received symbols. The MCLK input provides the reference clock for the DPLL at 15.36 MHz. Received data is then detected, with automatic correction for line signal polarity if necessary, and a flywheel synchronization circuit searches for and locks onto the frame and superframe syncwords. Frame lock will be maintained until errored sync words are detected for

480 ms. If a loss-of-sync condition persists for 480 ms the device will cease transmitting and go into a RESET state.

While the receiver is synchronized, data is descrambled using the specified polynomial, and the individual channels demultiplexed and passed to their respective processing circuits.

Whenever the loop is deactivated, either powered up or powered down, a Line Signal Detect circuit is enabled to detect the presence of an incoming 10 kHz wake-up tone if the far-end starts to activate the loop. The LSD circuit generates an interrupt and, if the device is powered down, pulls the LSD pin low; either of these indicators may be used to alert an external controller, which must respond with the appropriate commands to initiate the activation sequence (see the Activation section).

3.0 ACTIVATION CONTROL: OVERVIEW

The TP3410 contains an automatic sequencer for the complete control of the start-up activation sequence specified in the ANSI standard. Both the "cold-start" and the fast "warm-start" are supported. Interaction with an external controller requires only Activate Request and Deactivate Request commands, with the option of inserting breakpoints in the sequence for additional external control if desired. Automatic control of the "act" and "dea" bits in the M4 bit positions is provided, along with the specified 40 ms and 480 ms timers used during deactivation. A 15 second default timer is also included, to prevent system lock-up in the event of a failed activation attempt. Section 11 gives an overview of the activation handshake between the TP3410 and the controller. See TP3410 User's Manual AN-913 for additional information.

4.0 MAINTENANCE FUNCTIONS: OVERVIEW

4.1 M Channel Processing

In each frame of the superframe there are 6 "Overhead" bits assigned to various control and maintenance functions of the DSL. Some processing of these bits may be programmed via the Command Registers, while interaction with an external controller provides the flexibility to take full advantage of the maintenance channels. New data written to any of the overhead bit Transmit Registers is resynchronized internally to the next available complete superframe or half-superframe, as appropriate. In addition, the SFS pin may be used to indicate the start of each superframe in 1 direction, see Figure 2 and Register CR2.

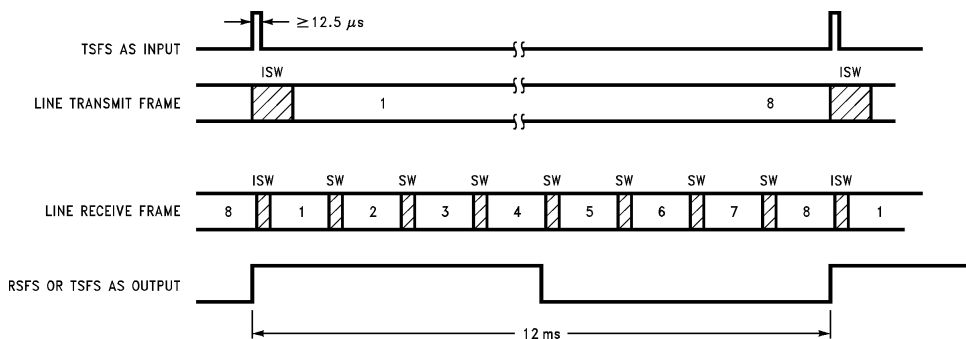

FIGURE 2. Superframe Sync Pin Timing

TL/H/9151-26

Functional Description (Continued)

4.2 Embedded Operations Channel

The EOC channel consists of 2 complete 12-bit messages per superframe, distributed through the M1, M2 and M3 bits of each half-superframe as shown in Table I. Each message is composed of 3 fields; a 3-bit address identifying the message destination, a 1-bit indicator for the data mode, i.e., encoded message or raw data, and an 8-bit information byte. The Microwire port or GCI Monitor Channel provides access to the complete 12 bits of every message in the TX EOC and the RXEOC Registers. If one of the defined encoded messages is received, e.g., Send Corrupted CRC, then the appropriate Command Register instruction must be written to the device to invoke the function.

4.3 M4 Bits

The M4 bit position of every frame is a transparent channel in which are transmitted data bits loaded from the M4 Transmit Register TXM4, one byte per superframe. On the receive side the M4 bits from one complete superframe are sent to a checking circuit which holds each new M4 byte and compares it against the previous M4 byte(s) for validation prior to sending it to the RXM4 Receive Register; Register OPR provides several options for control of this validation.

4.4 Spare M5 And M6 Bits

Overhead bits M5 and M6 in frame 1 (M51 and M61) and M5 in frame 2 (M52) are transparently transmitted from the Transmit M56 Spare Bit Register to the line. In the receive direction, data from these bit positions is sent to a checking circuit which holds the new M5/M6 spare bits and compares them against the previous M5/M6 bits for validation prior to sending them to the Receive M56 Spare Bit Register; the OPR Register provides several options for control of this validation.

4.5 CRC Circuit

In the transmit direction an on-chip crc calculation circuit automatically generates a checksum of the 2B + D + M4 bits using the polynomial $x^{12} + x^{11} + x^3 + x^2 + x + 1$. Once per superframe the crc is transmitted in the specified M5 and M6 bit positions (see Table I). In the receive direction a checksum is again calculated on the same bits as they are received and, at the end of the superframe, compared against the crc transmitted with the data. The result of this comparison generates a "Far End Block Error" bit (the febe bit), which is transmitted back towards the other end of the DSL in the next superframe. If there are no errors in a superframe, febe is set = 1, and if there is one or more errors febe is set = 0.

The TP3410 also includes a readable 8-bit Block Error Counter BEC1, which is decremented by 1 each superframe in which febe = 0 or nebe = 0 is received. Section 10.5 describes the operation of this counter.

On first application of power, and after the software reset (X'1880, X'1800), both the ECT1 as well as BEC1 are initialized to X'FF. See the Block Error Counter section for more details.

5.0 DIGITAL INTERFACE: ALL FORMATS

5.1 Clocking

In LT applications (network end of the Loop), the Digital System Interface (DSI) normally accepts BCLK and FS signals from the network, requiring the selection of DSI or GCI Slave mode in Register CR1. A Digital Phase-Locked Loop (DPLL #2) on the TP3410 allows the MCLK frequency to be plesiochronous (i.e. free-running) with respect to the network clocks, (BCLK and the 8 kHz FSA input). With a tolerance on the MCLK oscillator of 15.36 MHz \pm 100 ppm, the lock-in range of DPLL2 allows the network clock frequency to deviate up to \pm 50 ppm from nominal.

In NT applications, when the device is in NT mode and is slaved to loop timing recovered from the received line signal, DSI or GCI Master mode should normally be selected. In this case BCLK, FS and SCLK (15.36 MHz) signals are outputs which are phase-locked to the recovered clock. A slave-slave mode is also provided, however, in which the Digital Interface data buffers on the TP3410 allow BCLK and FSA/b to be input from an external source, which must be frequency-locked (but may take an arbitrary phase) to the received line signal; in this case DSI or GCI Slave mode should be selected.

5.2 Data Buffers

The TP3410 buffers the 2B + D data at the Digital Interface in elastic FIFOs, which are 3 frames deep in each direction. When the Digital Interface is a timing slave these FIFOs compensate for relative jitter and wander between the Digital Interface clocks (BCLK and FSA/b) and bit and frame timing at the Line Interface. Each buffer can absorb wander up to 18 μ s in \geq 10 secs without "slip", exceeding CCITT recommendation Q.502. Excessive wander causes a controlled slip of one complete frame.

6.0 DIGITAL INTERFACE DATA FORMATS IN MICROWIRE MODE (MW = 1)

When the MW pin is tied high to enable the Microwire Port for control and status, the Digital System Interface on the TP3410 provides a choice of four multiplexed formats for the B and D channel data, as shown in *Figure 3*. These apply in both LT and NT modes of the device, and selection is made via Register CR1. Selection of DSI Master or Slave mode must also be made in CR1. Within each format there is also an independent selection available to either multiplex the D channel (Tx and Rx) data on the same pins as the B channels, or via the separate D-channel access pins, DCLK, Dx and Dr, see Section 6.3.

Format 1: In Format 1, the 2B + D data transfer is assigned to the first 18 bits of the frame on the Bx and Br pins. Channels are assigned as follows: B1 (8 bits), B2 (8 bits), D (2 bits), with the remaining bits ignored until the next frame sync pulse. When the D channel port is enabled (see CR2), only the 2 B channels use the Bx and Br pins; the D bits are assigned to the 17th and 18th bits of the frame on the Dx and Dr pins. *Figure 3-1* shows this format in DSI Slave Mode, and *Figure 3-4* shows DSI Master Mode.

Functional Description (Continued)

Format 2: Format 2 is the IDL, in which the 2B+D data transfer is assigned to the first 19 bits of the frame on the Bx and Br pins. Channels are assigned as follows: B1 (8 bits), D (1 bit), 1 bit ignored, B2 (8 bits), D (1 bit), with the remaining bits ignored until the next frame sync pulse. *Figure 3-2* shows this format in DSI Slave Mode, and *Figure 3-5* shows DSI Master Mode.

Format 3: This format provides time-slot assignment capability for the B1 and B2 channels, which can be independently assigned to any 8-bit wide time-slot from 64 (or less) on the Bx and Br pins; the Transmit and Receive directions are also independently assignable. Also the D channel can be assigned to any 2-bit wide time-slot from 256 (or less) on the Bx and Br pins (D port disabled) or

on the Dx and Dr pins (see D-Channel Port section). *Figure 3-3* shows this format in DSI Slave Mode, and *Figure 3-6* shows DSI Master Mode; see also Section 6.2.

Format 4: This is similar to the GCI format for the 2B+D channels, but excludes the Monitor channel and C/I channel. Channels are assigned to the first 26 bits of each frame as follows: B1 (8 bits), B2 (8 bits), ignored (8 bits), D (2 bits). The remaining bits in the frame are ignored until the next frame sync pulse. The relationship between BCLK and data is the same as in the GCI mode for GCI Channel 0, see *Figure 7* (in DSI Master Mode, BCLK = 512 kHz and FS_a is a square wave output).

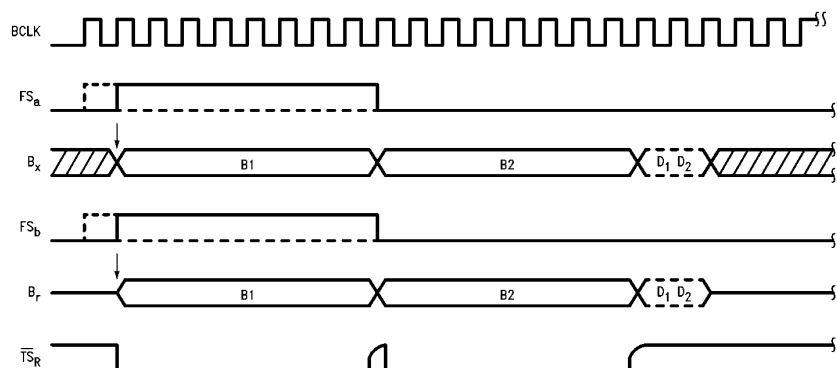

FS_a defines B1 channel for Tx.
FS_b defines B1 channel for Rx.

FIGURE 3-1. DSI Format 1: Slave Mode

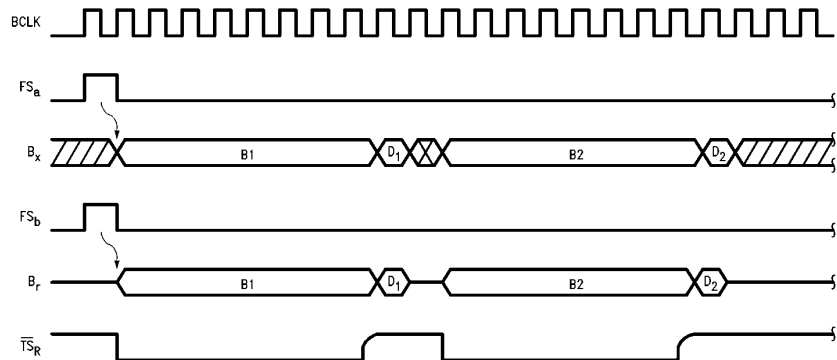

Delayed timing mode must be selected;
Time-slot immediate mode only (no TSA).

FIGURE 3-2. DSI Format 2 (IDL): Slave Mode

Functional Description (Continued)

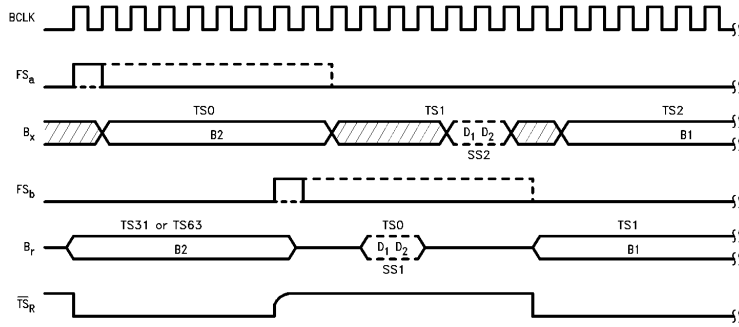

TL/H/9151-7

Transmit slots are numbered relative to FSa, and receive slots relative to FSb.
Shown with examples of offset frames and Time-slot Assignments.

FIGURE 3-3. DSI Format 3 (Time-Slot Assignment) : Slave Mode

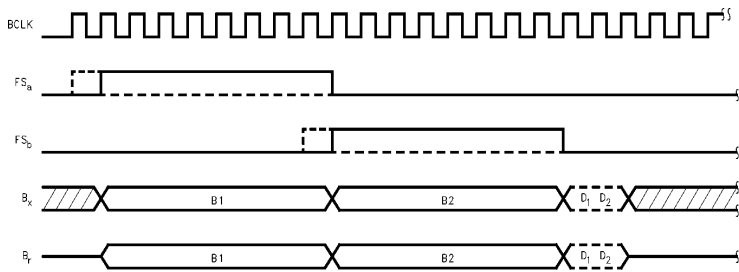

TL/H/9151-8

FSa defines B1 channel for Tx and Rx.
FSb defines B2 channel for Tx and Rx.

FIGURE 3-4. DSI Format 1: Master Mode

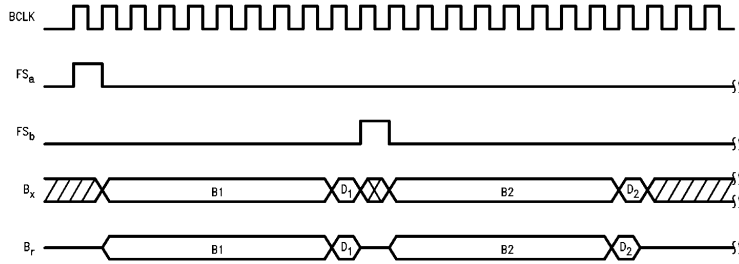

TL/H/9151-9

FIGURE 3-5. DSI Format 2 (IDL): Master Mode

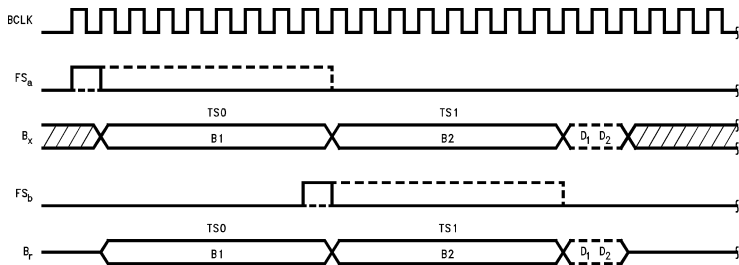

TL/H/9151-10

Transmit and Receive slots are numbered relative to FSa.

FIGURE 3-6. DSI Format 3: Master Mode

Functional Description (Continued)

6.1 FS Relationship To Data (Microwire Mode)

For applications on a line-card, in DSI Slave Mode, the B and D channel slots can be interfaced to a Time-Division Multiplexed (TDM) bus and assigned to a time-slot. The repetition rate of the FS input signals must be 8 kHz and must be synchronized to the BCLK input, which may be any frequency from 256 kHz to 4.096 MHz in 8 kHz increments. Two different relationships may be established between the FS inputs and the actual time-slots on the PCM busses by setting the DDM bit in Control Register CR1, see *Figures 3, 11 and 12*. Non-delayed data mode is similar to long frame timing on the TP3050/60 series of devices (COMBO I): the time-slots are defined by the 8-bit duration FSA and FSb signals. The alternative is to use Delayed Data Mode, which is similar to short frame sync timing on COMBO I, in which each FS input indicates the start of the first time-slot.

Serial B channel data is shifted into the Bx input during each assigned Transmit time-slot on the falling edges of BCLK. During each assigned Receive time-slot, the Br output shifts data out on the rising edges of BCLK. Also, with the device in LT Mode, the $\overline{\text{TSr}}$ pin is an open drain n-channel pull-down output which goes low during the selected time-slots for the received B1 and B2 channels at the Br pin to control the TRI-STATE Enable of a backplane line-driver; it is high-impedance at all other times.

In NT Mode, when DSI Master mode is selected, FSA and FSb are outputs indicating the B1 (or TS0) and the B2 (or TS1) channels respectively. BCLK is also an output at the serial data shift rate, which is dependent on the format selected. Again, either a delayed or non-delayed relationship between FSA, FSb and the start of the first time-slot can be selected.

6.2 B Channel Time-slot Assignment; Format 3 Only (Microwire Mode)

In Format 3 only, the TP3410 provides programmable time-slot assignment for selecting the Transmit and Receive B channel time-slots. Following power-on, the device is automatically in Non-delayed Data Mode; if Delayed Data Mode is required it must first be selected (see CR1) prior to using Time-slot Assignment, and the FS pulses must conform to the Delayed Data timing format. The actual transmit and receive time-slots are then determined by the internal Time-slot Assignment counters, programmed via Control Registers TXB1, TXB2, RXB1 and RXB2. Normally used in DSI Slave mode, Format 3 allows a frame to consist of up to 64 time-slots of 8 bits each with BCLK up to 4.096 MHz.

A new assignment becomes active on the second frame following the end of the 16-bit Chip Select.

6.3 D Channel Port Selection (Microwire Mode)

In any of the DSI Formats, the 2 D channel bits per frame may either be multiplexed with the B channels on the Bx and Br pins, or may be accessed via the separate D channel port consisting of Dx and Dr. Furthermore, when using the separate D port the data shift clock may either be a continuous, unframed data stream using the 16 kHz clock output at DCLK, see *Figure 4*, or may use the BCLK, see *Figure 5*. Selection of these options is via Control Register CR2.

6.4 D Channel Time-Slot Assignment

In addition to B channel TSA, Format 3 allows independent Time Slot Assignment for the Transmit and Receive D channels, which may be programmed via Registers TXD and RXD. As with the B channels, up to 64 time-slots are available if BCLK = 4.096 MHz, and in addition the 2 D bits may be assigned, in pairs, to specific bit locations within the time-slot; that is in bits 1 and 2; 3 and 4; 5 and 6; or 7 and 8. D channel TSA may be used either with the D channel multiplexed with the B channel data, or with the separate D Channel port clocked with BCLK; it cannot be used with the 16 kHz clock option at DCLK.

Summary of DSI Slave Mode Options

Function	Format Number			
	1	2	3	4
FSa	Tx B1	Tx B1	Tx TS0	Tx B1
FSb	Rx B1	Rx B1	Rx TS0	Rx B1
Non-Delayed Timing?	Yes	No	Yes	Yes
Delayed Timing?	Yes	Yes	Yes	No
Tx and Rx Frames with Any Phase?	Yes	Yes	Yes	Yes
TSA Available?	No	No	Yes	No
D Port Available?	Yes	Yes	Yes	Yes

Summary of DSI Master Mode Options

Function	Format Number			
	1	2	3	4
FSa	B1	B1	TS0	B1
FSb	B2	B2	TS1	B2
FS Formats	Non-Delayed and Delayed	Delayed Only	Non-Delayed and Delayed	Non-Delayed Only
TSA Available?	No	No	Yes	No
D Port Available?	Yes	Yes	Yes	Yes

Note: All Formats: Tx and Rx frames always aligned.

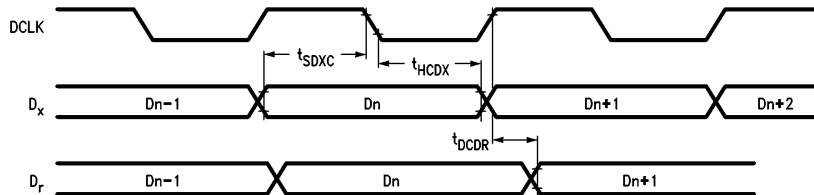

FIGURE 4. D-Port Interface Timing Using DCLK in 16 kHz Mode

TL/H/9151-11

Functional Description (Continued)

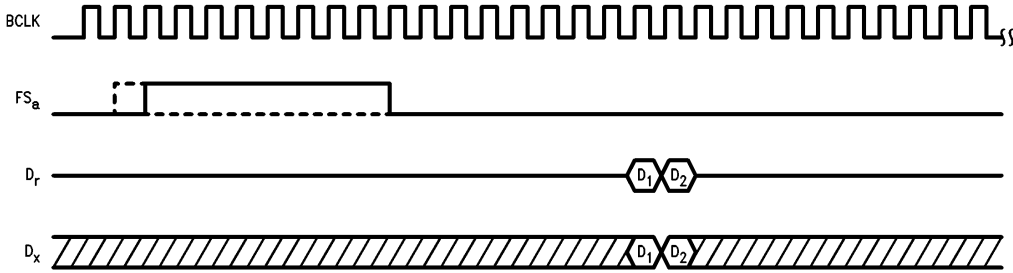

FIGURE 5-1. Format 1

TL/H/9151-12

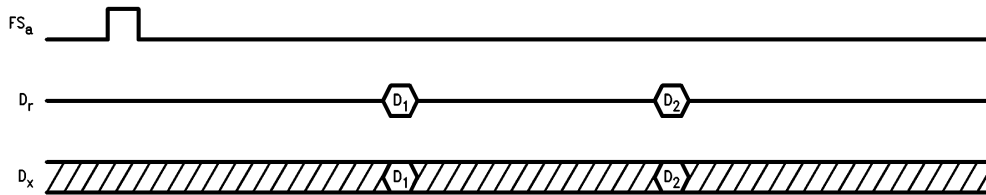

FIGURE 5-2. Format 2

TL/H/9151-13

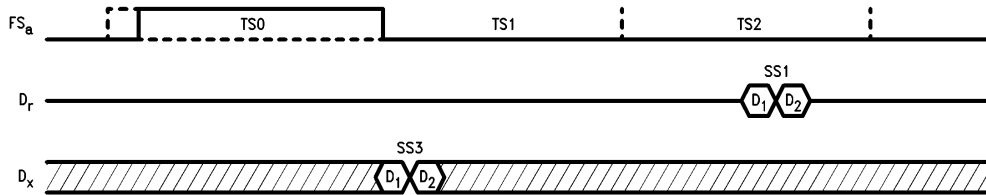

FIGURE 5-3. Format 3

TL/H/9151-14

Shown with example of Time-slot Assignment, and FS_a = FS_b

FIGURE 5. D-Port Interface Timing Using BCLK

7.0 MICROWIRE CONTROL PORT (MW = 1)

When Format 1, 2, 3 or 4 is used, control information and maintenance channel data is written into and read back from the TP3410 via the Microwire port consisting of the control clock CCLK; the serial data input, CI, and output, CO; the Chip Select input, \overline{CS} and the interrupt output \overline{INT} . The MW pin must be tied high to enable this port, and the port may be used regardless of whether the device is powered up or down. Figures 6 and 14 show the timing, which is compatible with the Microwire port on the HPC and COPs families of microcontrollers, and Tables II and III list the control functions and status indicators.

All read and write operations require 2 contiguous bytes. As shown in Tables II and III, the first byte is the register ad-

dress and the second byte is the data byte. Status Registers request service under control of the Interrupt Stack, with the priority order listed in Table III.

To shift data to and from the TP3410, CCLK must be pulsed high 16 times while \overline{CS} is low. Data on the CI input is shifted into the serial input register on the rising edge of each CCLK pulse; simultaneously, data is shifted out from CO on each falling edge of CCLK. Bit 7 of byte 1 is shifted first. \overline{CS} must return high at the end of the 2nd byte, after which the contents of the input shift register are decoded, and the data is loaded into the appropriate programmable register. Pulling \overline{CS} low also clears the \overline{INT} pin if it was pulled low; if another interrupt condition is queued on the Interrupt Stack it can only pull the \overline{INT} pin low when \overline{CS} is high. When \overline{CS} is high the CO pin is in the high-impedance state, enabling the CO pins of many devices to be multiplexed together.

Functional Description (Continued)

The TP3410 has an enhanced MICROWIRE port such that it can connect to standard MICROWIRE master devices (such as NSC's HPC and COP families) as well as the SCP (serial control port) interface master from the Motorola micro-controller family. SCP is supported on devices such as MC68302 or the MC145488 HDLC.

TP3410 supports two popular formats used in typical terminal equipment applications.

1. CCLK idling LOW when \overline{CS} pin is inactive HIGH, pulsing LOW/HIGH/LOW for 16 clocks, then returning back to LOW for idle condition. Data is output on CO pin on the negative edge and data sampled in on the positive edge of CCLK. This format (shown in *Figure 14b*) is normally used with NSC's microcontrollers from the HPC or the COP8 family.
2. CCLK idling HIGH when \overline{CS} pin inactive HIGH, pulsing HIGH/LOW/HIGH for 17 clocks, then returning back to HIGH for idle condition. Data is output on CO pin on the negative edge and data sampled in on the positive edge of CCLK. This format (shown in *Figure 14c*) is normally used with other alternate microcontrollers in the industry. The first 16 clock pulses are the normal low-going pulses to shift and sample the microwire data. **The 17th pulse is generated with software** by toggling the CCLK clock polarity bit on the SCP port of MC6302 or MC145488. It is necessary to deactivate the \overline{CS} pin (bring it high) while the CCLK is low as shown in *Figure 14c*.

8.0 GCI MODE (MW = 0)

Selected by tying the MW pin low, the GCI interface is designed for systems in which PCM and control data are multiplexed together into 4 contiguous bytes per 8 kHz frame. Furthermore, in Subscriber Line Cards and NT1-2's (where the Digital Interface is slaved to external timing) up to 8 GCI channels may be carried in 1 frame of a GCI multiplex, with a combined bit rate from 256 kb/s up to 3088 kb/s. Pin-programmable GCI-channel assignment for 8 GCI channels is provided.

Note that GCI mode on the TP3410 requires messages in the Embedded Operations Channel to be processed by a local microcontroller. In Line card and TE applications, GCI mode can be used with a device such as the TP3451 HDLC controller to provide the interface for the microcontroller to access the EOC Registers. To use the device in an NT-1 or Regenerator, a microcontroller is required and Microwire mode should be used on the TP3410.

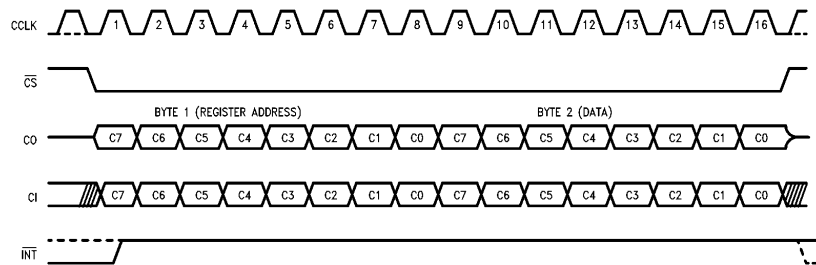

FIGURE 6. Microwire Control Port Timing: MW = 1

TL/H/9151-15

8.1 GCI Physical Interface

The interface physically consists of four wires:

- Transmit data to line: Bx
- Receive data from line: Br
- Bit clock at 2 cycles/bit: BCLK
- 8 kHz frame sync: FSa

Data is synchronized by the BCLK and FSa clock inputs. FSa insures re-initialization of the time-slot counter at the beginning of each 8 kHz frame, with the rising edge of FSa being the reference time for the first GCI channel bit. Data is clocked in both directions at half the BCLK input frequency. Data bits are output from the device on a rising edge of BCLK and sampled on the second falling edge of BCLK; unused slots are high impedance. Br is an open-drain n-channel output, with internal detection for contention resolution on the Monitor and C/I channels between devices attempting to use the same GCI channel (typically in a TE application).

A device may be either the Master or Slave of the GCI timing. As a Master it is the source of BCLK, FSa and FSb, which are synchronized to the data received from the line, and GCI channel 0 is always used. As a GCI Slave, BCLK and FSa must be sourced externally, typically from a system backplane, and pins S0-S2 must be connected high or low to select the required GCI channel. To use the single channel mode, a 512 kHz BCLK is required, and S2, S1 and S0 must be connected to GND (GCI Channel 0). To use the multiplex mode with a GCI Slave device, the 4 pins are commoned between up to 8 devices, forming a "wire-AND" connection with the Br pins. The BCLK frequency must be at least $n \times 512$ kHz, where n is the number of devices. In fact BCLK may be operated up to 6144 kHz if required, to leave up to 4 additional GCI channels unoccupied by TP3410's (and available for other uses). Clock and channel selection are shown in the following table:

Pin Name	LT and NT1-2	NT1 and TE
MW	0	0
MO	0 (GCI Slave)	1 (GCI Master)
S2/CLS	S2 (msb)	CLS = 0: 512 kHz CLS = 1: 1536 kHz
S1	S1	0
S0/FSb	S0 (lsb)	FSb

Functional Description (Continued)

8.2 GCI Frame Structure

Figure 7 shows the frame structure at the GCI interface. One GCI channel supports one TP3410 using a bandwidth of 256 kbit/s, consisting of the following channels multiplexed together in an 8 kHz frame:

- B1 channel at 8 bits per frame;
- B2 channel at 8 bits per frame;
- Monitor (M) channel at 8 bits per frame;
- Signalling and Control (SC) channel, which is structured as follows:
 - D Channel at 2 bits per frame;
 - C/I channel at 4 bits per frame;
 - A bit, for acknowledgement of M channel bytes;
 - E bit, which indicates byte boundaries when multiple-byte messages are transferred via the M channel.

8.3 Monitor Channel

The GCI Monitor channel (byte 3) is used to access all the Command Registers shown in Table II, with the exception of the Activation Control Register, and all the Status Registers shown in Table III with the exception of the Activation Indication Register. Each access to or from one of the listed registers requires a 2-byte message transfer. As shown in Tables II and III, the first byte from the originating device contains the register address, and the second byte is the data byte. Status Registers originate messages in the Monitor channel under control of the Interrupt Stack (in the same manner as when the TP3410 is used in Microwire Mode). In addition a protocol is used, based on the E and A bits in byte 4, to provide an acknowledgement of each Monitor channel byte in either direction, see Figure 8.

When no Monitor Channel message is being transferred, the E bit, and the A bit in the reverse direction, are high-impedance (and pulled high by the external resistor if no other

device is active in that channel). To initiate a transfer, a device must first verify that it has received the A bit = 1 for at least 2 consecutive GCI frames from the other device before starting the transfer. It then sends the first byte in the Monitor channel, with the associated E bit = 0, and repeats the byte in the next GCI frame. Normally, the receiving device will verify receiving the same byte in 2 consecutive frames and acknowledge this by setting A = 0 for at least 2 frames. If not, the message is aborted by sending A = 0 for only 1 frame.

On detecting the acknowledgement, the sending device then sends the 2nd of the 2 bytes in 2 consecutive GCI frames (or until it is acknowledged), with E = 1 to indicate this is the last byte of the transfer. The receiver verifies this byte is the same for 2 frames and sends an acknowledgement by sending A = 1 in the next frame. If an abort is required, the receiver will maintain A = 1 for another frame. If a Monitor channel message originated by the TP3410 is aborted, it will repeat the complete message until it is successfully acknowledged.

8.4 C/I Channel

The C/I (Command/Indicate) channel in GCI byte 4 is used solely to access the Activation Control Register and the Activation Indication Register in the TP3410. A complete description of these registers is found in Section 11, including the coding of the 4-bit messages. Unlike the Microwire Mode of the device, however, the contents of these 2 registers are transferred repeatedly in the C/I channel, once per GCI frame. A change in transmit message is originated by a change in the Activation Indication Register, while a change in received message is verified in 2 consecutive GCI frames before updating the Activation Control Register and taking the appropriate action.

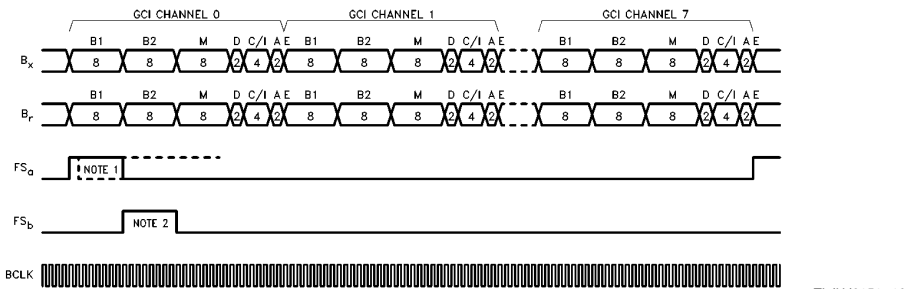

Note 1: As an output (GCI Master) FS_a is high for 8-bit intervals (16 BCLK cycles). As an input (GCI Slave) FS_a must be high for ≥ 1 BCLK cycle.

Note 2: The FS_b output is provided only in GCI Master Mode.

FIGURE 7. GCI Frame Structure is an Example of Multiplex Mode with BCLK = 4.096 MHz

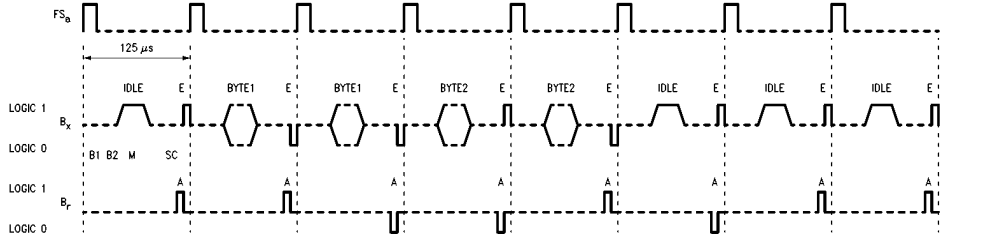

FIGURE 8. GCI Monitor Channel and E and A Bit Protocol

Functional Description (Continued)

TABLE II. Command Registers

Function	Byte 1 (Register Address)								Byte 2 (Data)							
	7	6	5	4	3	2	1	0	7	6	5	4	3	2	1	0
No Operation (NOP)	0	0	0	0	0	0	0	0	0	0	0	0	0	0	0	0
Write OPR	0	0	1	0	0	0	0	0	CIE	EIE	FIE	OB1	OB0	OC1	OC0	0
Readback OPR	0	0	1	0	0	0	0	1	X	X	X	X	X	X	X	X
Write CR1	0	0	1	0	0	0	1	0	FF1	FF0	CK2	CK1	CK0	DDM	CMS	BEX
Readback CR1	0	0	1	0	0	0	1	1	X	X	X	X	X	X	X	X
Write CR2	0	0	1	0	0	1	0	0	SSS	NTS	DMO	DEN	DD	BP1	BP2	0
Readback CR2	0	0	1	0	0	1	0	1	X	X	X	X	X	X	X	X
Write CR3	0	0	1	0	0	1	1	0	LB1	LB2	LBD	DB1	DB2	DBD	TLB	0
Readback CR3	0	0	1	0	0	1	1	1	X	X	X	X	X	X	X	X
Write CR4	0	0	1	0	1	1	0	0	SH9	AACT	WS	333 Hz	saif	TFB0	RFS	LFS
Readback CR4	0	0	1	0	1	1	0	1	X	X	X	X	X	X	X	X
Write TXB1 TSA	0	0	1	1	0	0	0	0	0	0	TS5	TS4	TS3	TS2	TS1	TS0
Readback TXB1	0	0	1	1	0	0	0	1	X	X	X	X	X	X	X	X
Write TXB2 TSA	0	0	1	1	0	0	1	0	0	0	TS5	TS4	TS3	TS2	TS1	TS0
Readback TXB2	0	0	1	1	0	0	1	1	X	X	X	X	X	X	X	X
Write RXB1 TSA	0	0	1	1	0	1	0	0	EB1	ED	TS5	TS4	TS3	TS2	TS1	TS0
Readback RXB1	0	0	1	1	0	1	0	1	X	X	X	X	X	X	X	X
Write RXB2 TSA	0	0	1	1	0	1	1	0	EB2	0	TS5	TS4	TS3	TS2	TS1	TS0
Readback RXB2	0	0	1	1	0	1	1	1	X	X	X	X	X	X	X	X
Write TXD	0	0	1	1	1	0	0	0	DX5	DX4	DX3	DX2	DX1	DX0	SX1	SX0
Readback TXD	0	0	1	1	1	0	0	1	X	X	X	X	X	X	X	X
Write RXD	0	0	1	1	1	0	1	0	DR5	DR4	DR3	DR2	DR1	DR0	SR1	SR0
Readback RXD	0	0	1	1	1	0	1	1	X	X	X	X	X	X	X	X
Write TXM4	0	1	0	0	0	0	0	0	ACT	M42	M43	M44	M45	M46	M47	M48
Write TXM56	0	1	0	0	0	0	1	0	0	0	LEC	M51	M61	M52	TFB	CTC
Write ACT Register	0	1	0	0	0	1	0	0	0	0	0	0	C4	C3	C2	C1
Write ECT1	0	1	0	0	0	1	1	0	O7	O6	O5	O4	O3	O2	O1	O0
Read BEC1	0	1	0	0	0	1	1	1	X	X	X	X	X	X	X	X
Write TX EOC Register	0	1	0	1	ea1	ea2	ea3	dm	ei1	ei2	ei3	ei4	ei5	ei6	ei7	ei8

Note 1: Bit 7 of byte 1 is always the first bit clocked into the device.

Note 2: In the Tx EOC Register:

ea1 = the msb of the EOC destination address;

ea2 = bit 2 of the EOC destination address;

ea3 = the lsb of the EOC destination address;

dm = the EOC data/message mode indicator.

Note 3: X = don't care (it is recommended that these bits be set = 0).

Functional Description (Continued)

TABLE III. Status Registers

Function	Byte 1 (Register Address)								Byte 2 (Data)							
	7	6	5	4	3	2	1	0	7	6	5	4	3	2	1	0
READABLE CONFIGURATION REGISTERS																
Default (No Change on a Write Cycle)	0	0	0	0	0	0	0	0	0	0	0	0	0	0	0	0
OPR Contents	0	0	1	0	0	0	0	1	CIE	EIE	FIE	OB1	OB0	OC1	OC0	0
CR1 Contents	0	0	1	0	0	0	1	1	FF1	FF0	CK2	CK1	CK0	DDM	CMS	BEX
CR2 Contents	0	0	1	0	0	1	0	1	SSS	NTS	DMO	DEN	DD	BP1	BP2	0
CR3 Contents	0	0	1	0	0	1	1	1	LB1	LB2	LBD	DB1	DB2	DBD	TLB	0
CR4 Contents	0	0	1	0	1	1	0	1	SH9	AACT	WS	333 Hz	saif	TFB0	RFS	LFS
TXB1 Contents	0	0	1	1	0	0	0	1	0	0	TS5	TS4	TS3	TS2	TS1	TS0
TXB2 Contents	0	0	1	1	0	0	1	1	0	0	TS5	TS4	TS3	TS2	TS1	TS0
RXB1 Contents	0	0	1	1	0	1	0	1	EB1	ED	TS5	TS4	TS3	TS2	TS1	TS0
RXB2 Contents	0	0	1	1	0	1	1	1	EB2	0	TS5	TS4	TS3	TS2	TS1	TS0
TXD Contents	0	0	1	1	1	0	0	1	DX5	DX4	DX3	DX2	DX1	DX0	SX1	SX0
RXD Contents	0	0	1	1	1	0	1	1	DR5	DR4	DR3	DR2	DR1	DR0	SR1	SR0
BEC1 (Note 2)	0	1	0	0	0	1	1	1	ec7	ec6	ec5	ec4	ec3	ec2	ec1	ec0
REGISTERS WHICH GENERATE A MICROWIRE INTERRUPT OR GCI MONITOR CHANNEL MESSAGE (Note 4)																
RXM4	0	1	0	0	0	0	0	0	M41	M42	M43	M44	M45	M46	M47	M48
RXM56 Spare Bits	0	1	0	0	0	0	1	0	0	ES2	ES1	M51	M61	M52	RFB	NEB
ACT Indication Reg	0	1	0	0	0	1	0	0	0	0	0	0	C4	C3	C2	C1
BEC1 (Note 2)	0	1	0	0	0	1	1	0	ec7	ec6	ec5	ec4	ec3	ec2	ec1	ec0
RX EOC Register (Note 3)	0	1	0	1	ea1	ea2	ea3	dm	ei1	ei2	ei3	ei4	ei5	ei6	ei7	ei8

Note 1: Bit 7 of byte 1 is always the first bit clocked into the device.

Note 2: BEC1 may be polled, via the appropriate read command (see Table II), at any time to read the current error count.

Note 3: In the Rx EOC Register:

- ea1 = the msb of the EOC destination address;
- ea2 = bit 2 of the EOC destination address;
- ea3 = the lsb of the EOC destination address;
- dm = the EOC data/message mode indicator.

Note 4: Changes in contents of these registers are queued on a stack which generates interrupts or messages in the following priority order:

1. Register Readback request.
2. ACT Indication Register (Microwire only).
3. RXM4 Register.
4. RX EOC Register.
5. RXM56 Spare Bits Register.
6. BEC1 Register.

Functional Description (Continued)

9.0 COMMAND REGISTER FUNCTIONS

All addressing and bit-level functions are the same for both the Microwire and GCI Monitor Channels, except where noted. Register addresses are listed in Table II. An asterisk * indicates the Power-on Reset state of each function. The device modes and Transmit M bits should be programmed while the device is powered down.

9.1 Writing to Command Registers

A command may be written to a register to modify its contents by setting byte 1 bit 0=0. Registers CR1, 2, 3, OPR and the Time-Slot Assignment registers may also be read-back to verify the contents by addressing each register with byte 1 bit 0=1. In Microwire Mode, if the device has no data waiting to be read during a command cycle it will return X'0000 (No Change).

9.2 Reading Back Command Registers for Verification

To read back the current state of one of the write-able registers, the appropriate readback command must first be loaded in via the control channel; this will cause an interrupt to be sent to the interrupt stack. In Microwire mode the interrupt must be serviced by a read cycle, in which the command should be a NOP (or a new command). In this cycle the previously addressed register is read back, with byte 1 bit 0=1. In GCI mode, the interrupt stack generates an autonomous one-way message in the Monitor Channel. If any other interrupt conditions should occur during the readback command cycle, the readback result will be queued at the bottom of the stack, and will not generate its interrupt or message until all other interrupts are cleared.

9.3 Configuration Register CR1: Digital Interface

Byte 2							
7	6	5	4	3	2	1	0
FF1	FF0	CK2	CK1	CK0	DDM	CMS	BEX

*CR1 is set to X'00 at Power-On Reset.

FF1, FF0: Digital System Interface Frame Format Selection

These bits are effective in Microwire Mode only (MW=1). They select the Digital Interface format as described in Section 6.

Format	FF1	FF0
*1	0	0
2	0	1
3	1	0
4	1	1

CK0–CK2: Digital Interface Clock Select

In Microwire Mode only, and if DSI Master is selected (CMS = 1), CK0–CK2 bits select from a choice of 5 frequencies for the BCLK output. (In GCI Mode, these bits have no effect.) The frequency of 256 kHz is not valid with Format 4.

CK2	CK1	CK0	BCLK Frequency:
0	0	0	*256 kHz Master
0	0	1	512 kHz Master
0	1	0	1536 kHz Master
0	1	1	2048 kHz Master
1	0	0	2560 kHz Master

DDM: Delayed Data Mode Select

For Microwire mode, see Section 6.1: FS Relationship to Data. In GCI Mode or Format 4 this bit has no effect.

*DDM = 0 for non-delayed data mode (see Figure 11).

DDM = 1 for delayed data mode (see Figure 12).

CMS: DSI Clock Master/Slave Select

In Microwire Mode (MW = 1):

CMS = 0 for DSI Slave; may be used in either LT or NT Modes

CMS = 1 for DSI Master; may be used in either LT or NT Modes, but when in LT Mode, must also send X'1840. See the TP3410 User's Manual AN-913 Section 4.5 for details.

In GCI Mode (MW = 0) this bit has no effect; the MO pin selects GCI Master or Slave.

BEX: B Channel Exchange

This command enables the two B channels to be exchanged as the data passes through the device between the Digital Interface and the Line in both directions. It should not be used if any loopback is selected in the device.

*BEX = 0 for B channels mapped direct, B1 to B1 and B2 to B2.

BEX = 1 for B channels exchanged, B1 to B2 and B2 to B1.

9.4 Configuration Register CR2: Device Modes

Byte 2							
7	6	5	4	3	2	1	0
SSS	NTS	DMO	DEN	DD	BP1	BP2	0

*CR2 is set to X'00 at Power-On Reset.

SSS: Superframe Synchronization Select

This bit is effective in LT mode only; in NT mode the SFS pin is an output. When SSS = 0, SFS is an input which synchronizes the transmit superframe counter on the line.

When SSS = 1, SFS is an output superframe marker pulse.

NTS: NT or LT Select

*NTS = 0 for LT Mode.

NTS = 1 for NT Mode.

DEN: D Channel Port Select

*When DEN = 0, the D channel port is disabled and the D bits are transferred on the Br and Bx pins, clocked by BCLK. The Dx pin must also be tied to GND for correct operation.

When DEN = 1, the D channel port is enabled; D bits are transferred on the Dr and Dx pins in a mode selected by the DMO bit, see Section 6.3.

DMO: D Channel Transfer Mode Select

This bit is significant only when the D channel port is selected (DEN bit = 1).

When DMO = 1, D channel data is shifted in and out on Dx and Dr pins in a continuous mode at 16 kbit/s on the falling and rising edges of DCLK respectively, see Figure 4.

When DMO = 0, D channel data is shifted in and out on Dx and Dr pins in a burst mode at the BCLK frequency when the assigned time-slots are active, see Figure 5.

DD: 2B + D Data Disabling

*When DD = 0, 2B + D channel transfer is enabled as soon as the line is completely synchronized.

When DD = 1, B and D channel transfer is inhibited. The data transmitted to line is preset to send scrambled 1's with the device in NT mode or scrambled 0's if the device is in LT

Functional Description (Continued)

mode, and the 2B+D slots at the receive digital interface port(s) are in the high impedance state.

BP1: Not Used

This bit is not used and should always be set to zero.

*BP1 = 0

BP2: Activation Breakpoint

This bit is effective only in LT mode. It provides for the start-up sequence to be either automatically controlled by the TP3410, or for the external controller to be able to halt the sequence at J7. The controller can complete start-up by sending "AC" to the ACT register (X'440C). For more information, see Section 11.0, Activation/Deactivation.

*BP2 = 0 for Breakpoint disabled.

BP2 = 1 for Breakpoint enabled.

9.5 Configuration Register CR3: Loopbacks

Byte 2							
7	6	5	4	3	2	1	0
LB1	LB2	LBD	DB1	DB2	DBD	TLB	0

*CR3 is set to X'00 at Power-On Reset.

Line Loopbacks Select: LB1, LB2, LBD

LB1, LB2, LBD bits, when set = 1, loopback each individual B1, B2, or D channel respectively from the line receive input to the line transmit output. They may be set separately or together. Each loopback is operated near the Bx and Br digital interface pins (or Dx and Dr if the D port is selected). These loopbacks may be either transparent, that is data received from the line is also passed on to the digital interface, or non-transparent, in which case the selected channel bits on the digital interface are in the high impedance state; transparency is controlled by the TLB bit.

Digital Loopbacks Select: DB1, DB2, DBD

DB1, DB2 and DBD bits, when set = 1, turn each individual B1, B2, or D channel respectively from the Bx input to the Br output (or Dx and Dr if the D port is selected). They may be set separately or together. Each loopback is operated near the digital interface pins; if Format 3 is selected there is no restriction on the time-slots selected for each direction. These loopbacks may be either transparent, that is data received from the Bx or Dx input is also transmitted to the line, or non-transparent, in which case the selected channel bits to the scrambler are forced low in LT mode or high in NT mode; transparency is controlled by the TLB bit.

TLB: Transparent Loop-Back Enabling

*TLB = 0 for non-transparent loopbacks (B1, B2 or D channel).

TLB = 1 for transparent loopbacks.

9.6 Configuration Register CR4: Device Control

A new configuration register (CR4) has been added to the Rev. 3 TP3410 device to allow control of new features.

Please also see TP3410 Users Manual AN-913.

Address X'2C.

Byte 2							
7	6	5	4	3	2	1	0
SH9	AACT	WS	333 Hz	saif	TFB0	RFS	LFS

*CR4 is set to X'0F at Power-On Reset.

SH9: Software H9 Control Bit

*SH9 = 0 (default state)

In NT mode, while SH9 = 0, a rev 3.x device in state H6, H7 or H8, H11 will enter the H9 state in response to receiving "dea = 0" for 3 consecutive superframes and then exit after 60 ms (to prevent a "hang up condition") to H12. With SH9 = 1, a TP3410 Rev 3.3 device in state H6, H7 or H8, H11 will generate a DP interrupt when it receives the "dea = 0" bit but is prevented from transitioning to device state H9. The device will still deactivate in response to loss of signal. Deactivating in this manner will however cause the NT mode device to perform a cold start only on subsequent activation attempts. The WS bit may be set = 1 for the device to attempt a warm start.

AACT: Activation Control Bit

*AACT = 0 (default state)

AACT = 1 enables auto-activation in either LT or NT modes. AACT = 0 disables it (default state) and the device behaves normally. Auto-activation can be used in applications such as Linecard, to allow the device to respond to an incoming 10 kHz wake-up tone (LSD) by powering itself up (PUP) and starting the activation procedure (AR) within the device.

WS: Warm Start

*WS = 0 (default state)

If this bit is set = 1, a Rev 3.3 device will attempt Warm Start activation after a deactivation. This function should only be necessary where Warm Start is preferred but SH9 = 1 is required.

333 Hz: Maintenance Test Tone

*333 Hz = 0 (default state)

333 Hz = 1 enables 333 Hz tone for Maintenance test modes (Bellcore requirement).

333 Hz = 0 disables it. This test tone is to be used in power up (after PUP) state but not activated.

Example of use:

Write PUP, X'2C1F to enable 333 Hz test tone, X'2C0F to disable 333 Hz tone.

saif: Select Analog Interface

*saif = 1 (default state)

saif = 1 indicates operation with the standard line interface that is compatible with Rev. 2.x devices. saif = 0 indicates use of the alternative line interface circuit with 0Ω on the line-side of the transformer. This circuit can provide benefit for linecard applications where line powering of remote NT1s and repeaters is required.

Example of use:

Write X'2C0F for standard line interface and X'2C07 for alternative line interface.

TFB0

*TFB0 = 1 (default state)

TFB0 = 0 forces transmit febe to 0 continuously for test purposes. TFB0 = 1 allows normal operation controlled by LFS and RFS. Note that this function was controlled by the TFB bit in TXM56 register in Rev. 2.x devices. The TFB bit in TXM56 bit is now (Rev. 3.x) active for one superframe only: if set to 0 by software, a superframe will transmit febe = 0, and then the TFB will be reset to 1 by the device. The software does not need to set it to 1.

Functional Description (Continued)

RFS: Remote Febe Select

*RFS = 1 (default state)

The state of the outgoing febe bit is computed based on the state of the TFB (bit 1) in TXM56 register. The TFB bit is set = 0 by the software to allow a febe bit from an adjacent DSL to be forwarded to the next section in the next superframe. This bit is self resetting (to 1) in Rev. 3.x devices. This is a change from the Rev. 2.x devices. If RFS = 0, then the outgoing febe does not depend on the state of the TFB bit in TXM56 register.

LFS: Local Febe Select

*LFS = 1 (default state)

The state of the outgoing febe bit is computed using the incoming nebe bit. If LFS = 0, the outgoing febe is not dependent on the incoming nebe.

Example of use:

A flexible control of the outgoing febe bit is provided to support the Segmented and Path Performance Monitoring recommendations in Bellcore TR 397.

For Rev. 2.8 type operation, set RFS = 1, LFS = 1 and TFB0 = 1. This setting will cause the transmit febe to be computed as OR of the incoming nebe bit and the state of the TFB bit in TXM56 (representing the adjacent section febe to be forwarded).

9.7 Configuration Registers TXB1, TXB2, RXB1, RXB2: B Channel TSA

These registers are effective only when Format 3 is selected.

TXB1 assigns the Transmit time slot for the B1 channel. TXB2 assigns the Transmit time slot for the B2 channel. RXB1 assigns the Receive time slot for the B1 channel. RXB2 assigns the Receive time slot for the B2 channel.

Register TXB1

Byte 2							
7	6	5	4	3	2	1	0
0	0	TS5	TS4	TS3	TS2	TS1	TS0

At Power-On Reset this register is initialized to X'00.

Register TXB2

Byte 2							
7	6	5	4	3	2	1	0
0	0	TS5	TS4	TS3	TS2	TS1	TS0

At Power-On Reset this register is initialized to X'01.

Register RXB1

Byte 2							
7	6	5	4	3	2	1	0
EB1	ED	TS5	TS4	TS3	TS2	TS1	TS0

At Power-On Reset this register is initialized to X'00.

Register RXB2

Byte 2							
7	6	5	4	3	2	1	0
EB2	0	TS5	TS4	TS3	TS2	TS1	TS0

*At Power-On Reset this register is initialized to X'01.

B Channels Time-Slot Assignment: TS5–TS0

The TS5–TS0 bits define the binary number of the time-slot when the B channel selected is shifted to or from the Bx and Br pins; time-slots are numbered from 0 to 63. New time-slot assignments become effective only at the beginning of a frame.

B1 and D Channel Enables: EB1; ED

*EB1 = 0 to disable the B1 channel; B1 is high-impedance at Br.

EB1 = 1 to enable the B1 channel (must also set DD=0 in CR2).

*ED = 0 to disable the D channel; D is high-impedance at Br or Dr.

ED = 1 to enable the D channel (must also set DD=0 in CR2).

B2 Channel Enable: EB2

EB2 = 0 to disable the B2 channel; B2 is high-impedance at Br.

EB2 = 1 to enable the B2 channel (must also set DD=0 in CR2).

9.8 Configuration Register TXD:

Transmit D Channel TSA

This register is effective only when Format 3 is selected. D channel TSA may be used when the D channel is accessed either via the Bx/Br or Dx/Dr pins, but the D channel port must be clocked with BCLK (DMO = 0 in CR2).

Byte 2							
7	6	5	4	3	2	1	0
DX5	DX4	DX3	DX2	DX1	DX0	SX1	SX0

*At Power-On Reset this register is initialized to X'08.

Transmit D Channel Time-Slot Assignment Select:

DX5–DX0, SX1–SX0

DX5–DX0 bits define the binary number of the 8-bit wide time-slot, where time-slots are numbered from 0 to 63. With in this selected time-slot, the SX1 and SX0 bits define the 2-bit wide sub-slot for the 2 D channel bits. Sub-slots are numbered 0 to 3, as shown in *Figures 5, 11 and 12* and the following table. New time-slot and sub-slot assignments become effective only at the beginning of a frame.

Sub-Slot		Bit Positions within Time-Slot
SX1	SX0	
*0	0	1, 2
0	1	3, 4
1	0	5, 6
1	1	7, 8

9.9 Configuration Register RXD:

Receive D Channel TSA

This register is effective only when Format 3 is selected. D channel TSA may be used when the D channel is accessed either via the Bx/Br or Dx/Dr pins, but the D channel port must be selected in the burst mode (DMO = 0 in CR2).

Functional Description (Continued)

Byte 2							
7	6	5	4	3	2	1	0
DR5	DR4	DR3	DR2	DR1	DR0	SR1	SR0

*At Power-On Reset this register is initialized to X'08.

Receive D Channel Time-Slot Assignment Select: DR5–DR0, SR1–SR0

DR5–DR0 bits define the binary number of the 8-bit wide time-slot, where the time-slots are numbered from 0 to 63. Within this selected time-slot, the SR1 and SR0 bits define the binary number of the 2 D channel bits. Sub-slots are numbered 0 to 3, as shown in *Figure 12* and the following table. New time-slot and sub-slot assignments become effective only at the beginning of a frame.

Sub-Slot		Bit Positions within Time-Slot
SR1	SR0	
*0	0	1, 2
0	1	3, 4
1	0	5, 6
1	1	7, 8

9.10 Configuration Register OPR: Overhead Bit Processing

This register controls the enabling/disabling of conditions which are sent to the Interrupt Stack (see 10.1) as a result of new data in the RXM4 and RXM56 Overhead Bits Registers, and the number of consecutive times a new bit or message is received before being validated. Flexibility is therefore provided to use hardware, external firmware routines or a combination of both for validation.

Byte 2							
7	6	5	4	3	2	1	0
CIE	EIE	FIE	OB1	OB0	OC1	OC0	0

*At Power-On Reset this register is initialized to X'00.

Near-End CRC Interrupt Enable: CIE

CIE

- *0 No Interrupt if near-end crc error (Block Error Counters still count).
- 1 RXM56 Status Register Interrupt is generated, with NEB = 0, each superframe in which the locally-generated crc result does not match the crc in the received superframe.

Block Error Counter Interrupt Enable: EIE

EIE

- *0 No Interrupt or Monitor channel message from Block Error Counters.
- 1 Block Error Counter Interrupts enabled.

febe Bit Interrupt Enable: FIE

FIE

- *0 No Interrupt if febe = 0 received (BEC1 still counts).
- 1 RXM56 Status Register Interrupt is generated, with RFB = 0, each superframe in which febe = 0 is received.

Receive Overhead Bits Interrupt Enable: OB1, OB0

These bits determine how many consecutive superframes must be received with the same new data in any of the overhead bit positions M41–M48, M51, M52 and/or M61 before an Interrupt(s) is generated for the RXM4 and/or RXM56 Register, as appropriate. Note that validation checking of the “act” and “dea” bits during activation/deactivation is not affected by OB1/OB0.

OB1 OB0

- *0 0 Interrupt every superframe (no checking).
- 0 1 Interrupt if any bit changed from previous superframe.
- 1 0 2 consecutive times for same new bit(s) before Interrupt.
- 1 1 3 consecutive times for same new bit(s) before Interrupt.

Receive Embedded Operations Channel Interrupt Enable: OC1, OC0

These bits determine how many consecutive half-superframes must be received with the same new address or data in the Embedded Operations Channel before an Interrupt is generated for the RX EOC Register.

OC1 OC0

- *0 0 Interrupt every received eoc message (no checking).
- 0 1 Interrupt every received eoc message which differs from previous message.
- 1 0 2 consecutive times for same new message before Interrupt.
- 1 1 3 consecutive times for same new message before Interrupt.

9.11 Transmit M4 Channel Register TXM4 (Write Only)

When the line is superframe synchronized, the device transmits the contents of this register to the line in the M4 overhead bit field once per superframe.

Byte 2							
7	6	5	4	3	2	1	0
ACT	M42	M43	M44	M45	M46	M47	M48

At Power-On Reset, and each time the device is Deactivated (or an Activation attempt fails), this register is initialized to X'7F.

ACT Bit

The ACT bit in the TXM4 register does not normally control the “act” bit in the M4 word transmitted to the line (see Table I). That “act” bit is generated automatically within the device and can be controlled through the Activation Control Register (see Table I and Section 11.0, Activation/Deactivation). In normal operation the ACT bit in the TXM4 register is ignored.

M42–M48 Bits

As shown in the Frame Formats in Table I, the functions of these bits depend on the mode of the device. They should be programmed as appropriate prior to an Activation Request, with the exception of the M42 bit in LT Mode. This is the dea bit, which is automatically controlled by the device in response to AR and DR commands; the M42 bit in this register is normally ignored in LT mode.

Functional Description (Continued)

9.12 Transmit M5/M6 Spare Bits Register TXM56 (Write Only)

Byte 2							
7	6	5	4	3	2	1	0
0	0	LEC	M51	M61	M52	TFB	CTC

At Power-On Reset, and each time the device is Deactivated (or an Activation attempt fails), this register is initialized to X'1E.

M51, M61, M52

The M51, M61, and M52 bits in this register control the appropriate overhead bits transmitted to the line. They should be set = 1 but may be subject to future standardization.

Transmit febe Bit Control: TFB

This bit should normally be set = 1. The febe bit transmitted in the M62 bit position is then automatically controlled by the device; febe is the far-end block error bit which is normally high, and set low when a crc (cyclic redundancy check) error has been detected in the previously received superframe. For test purposes, however, febe may be forced continuously low by setting TFB = 0.

Corrupt Transmit crc: CTC

To allow the normal calculation of the crc for the transmitted data to the line, set CTC = 0. In order to send a corrupted crc for test purposes, set CTC = 1, which causes the crc result to be continuously inverted prior to transmission.

Latched External Control: LEC

This bit directly controls the LEC output pin, in GCI mode.

9.13 Transmit EOC Register (Write Only)

When the line is fully superframe synchronized, the device continuously sends the contents of this register to the line twice per superframe in the EOC channel field. The register contents are loaded into the line transmit register every half superframe.

Byte 1				Byte 2							
3	2	1	0	7	6	5	4	3	2	1	0
ea1	ea2	ea3	dm	ei1	ei2	ei3	ei4	ei5	ei6	ei7	ei8

At Power-On Reset, and each time the device is Deactivated (or an Activation attempt fails), this register is initialized to X'FF.

The Tx EOC Register contains 12 bits which correspond to the 12 bits of a message in the Embedded Operations Channel, see Table I:

ea1, ea2 and ea3 correspond to the 3 EOC destination address bits, eoca1, eoca2, eoca3;

the dm bit indicates if the information is in message mode or data mode (data if dm = 0, message if dm = 1);

ei1–ei8 correspond to the 8 eoc data bits, eoci1–eoci8.

Only bits 7–4 of byte 1 are used to address this register, as shown in Table II.

9.14 Error Counter Threshold Register: ECT1

Byte 2							
7	6	5	4	3	2	1	0
O7	O6	O5	O4	O3	O2	O1	O0

At Power-On Reset this register is initialized to X'FF.

This register may be loaded with any value, which is then used to preset the Block Error Counter BEC1. BEC1 decrements 1 count for each block error. When the counter value reaches X'00 the BEC1 interrupt is sent to the stack (if enabled by EIE = 1 in the OPR reg.).

10.0 STATUS REGISTERS

All Status Register addressing and bit-level functions are the same for both the Microwire and GCI Monitor Channels, except where noted. Register addresses are listed in Table III.

10.1 Reading Status Registers In Response To An Interrupt

Conditions occurring in the device which generate Microwire interrupts or GCI Monitor Channel messages are queued in a stack, with a pre-defined priority, see Table III. In Microwire mode the \overline{INT} pin is pulled low and a NOP command should be loaded into the Microwire during the read cycle (or a valid command may be used to modify a register if required). In GCI mode, the interrupt stack generates an autonomous one-way message in the Monitor Channel.

10.2 Receive EOC Register

This register is significant only when the EOC channel processing is enabled (see register OPR).

Byte 1				Byte 2							
3	2	1	0	7	6	5	4	3	2	1	0
ea1	ea2	ea3	dm	ei1	ei2	ei3	ei4	ei5	ei6	ei7	ei8

The RX EOC Register contains 12 bits which correspond to the 12 bits of a message in the Embedded Operations Channel, see Table I: ea1, ea2 and ea3 correspond to the 3 EOC destination address bits, eoca1, eoca2, eoca3;

the dm bit indicates if the information is in message mode or data mode;

ei1–ei8 correspond to the 8 eoc data bits, eoci1–eoci8.

Only bits 7–4 of byte 1 are used to address this register, as shown in Table II.

When the line is fully superframe synchronized, the device extracts these 12 bits from the channel every half superframe. Each EOC message is validated according to the mode selected in Register OPR, and if a message contains a new address or new data, the Rx EOC Register is sent to the Control Interface, through an interrupt cycle request. If one of the defined coded commands is received, e.g., Send Corrupted CRC, then the appropriate Command Register instruction must be written to the device to select that function.

10.3 RXM4: Receive M4 Overhead Bits Register

This register is significant only when the Spare Bit processing is enabled (see register OPR).

Byte 2							
7	6	5	4	3	2	1	0
M41	M42	M43	M44	M45	M46	M47	M48

Functional Description (Continued)

The RXM4 Register consists of 8 bits, which correspond to the M4 overhead bit position in each of the 8 Basic Frames of a superframe. When the line is fully superframe synchronized, the device extracts from the M channel these 8 bits every superframe. At the end of each superframe, the register content is sent to the Interrupt stack, in accordance with the validation mode selected in Register OPR. M41, and M42 in NT mode, are only provided via this register while the line is fully activated (after AI). During the activation and deactivation sequences the “act” and “dea” bits are processed automatically, see the Activation Control section.

10.4 RXM56: Receive M5/M6 Spare Bits Status Register

This register is significant only when the Spare Bit processing is enabled (see register OPR).

Byte 2							
7	6	5	4	3	2	1	0
0	ES2	ES1	M51	M61	M52	RFB	NEB

Data in this register consists of 7 bits: M51, M52, M61 and RFB (RFB = receive febe, the far-end block-error indicator from the M62 bit position), all of which correspond to the overhead bits received once per superframe, plus NEB, which is an internally generated bit indicating a near-end block-error. Bits ES1 and ES2 are available in GCI mode only. When the line is fully superframe synchronized, the device loads the register with the received bits M51, M52, M61 and febe every superframe; in GCI mode the ES1 and ES2 input pins are also sampled. The 12-bit crc received from the far-end is also compared at the end of the superframe with the crc previously calculated by the device. If an error is detected, the febe bit in the transmit direction is automatically forced low in the next superframe and the NEB bit in this register is set low also. The register content is sent to the Interrupt stack at the end of each superframe.

10.5 Block Error Counter: BEC1

Byte 2							
7	6	5	4	3	2	1	0
ec7	ec6	ec5	ec4	ec3	ec2	ec1	ec0

At Power-On Reset this counter is preset = X'FF.

BEC1

This 8-bit counter is decremented by 1, starting from the value in the ECT1 register, if either febe=0 or nebe=0 in the same superframe. When the counter reaches X'00 (and if the Interrupt is enabled by means of the EIE bit in Register OPR), an interrupt is queued in the interrupt stack. The counter may also be read at any time; the count will be the ECT1 value minus the number of errors since the last read of this register. Reading the counter, or when the counter decrements to X'00, causes the count to be reset to the ECT1 value.

11.0 ACTIVATION/DEACTIVATION

A common coding table is used for the commands in the Activation Control Register and the status indicators in the Activation Indication Register. They control the Power-Up/Down, Activation and Deactivation states of the device. When the device is in GCI Mode, the 4 significant bits in these registers (3–0) continuously report their current contents in the C/I channel. In Microwire Mode the registers are addressed with a normal 16-bit cycle as shown in Table II.

11.1 Activation Control Register

Byte 2							
7	6	5	4	3	2	1	0
0	0	0	0	C4	C3	C2	C1

At Power-On Reset, and each time the device is Deactivated (or an Activation attempt fails), this register is initialized to X'0F.

Activation commands and status indicators are coded as follows:

CODE				LT MODE		NT MODE	
C4	C3	C2	C1	IND	COM	IND	COM
0	0	0	0	TIM*	PUP/DR	DP/LSD	PUP
0	0	0	1	X	RES	X	RES
0	1	0	0	EI	FA0	EI	SEI
0	1	0	1	X	PDN	X	PDN
0	1	1	0	SYNC	X	X	X
1	0	0	0	AP	AR	AP	AR
1	1	0	0	AI	AC	AI	AC
1	1	1	1	DI	DC*	DI	DC*

Note 1: X indicates reserved codes which should not be used.

11.2 Activation Commands

- PUP** This command powers up the device and starts the oscillator.
- PUP/DR** When the TP3410 is in the power-down state, this command powers up the device and starts the oscillator. In LT mode only, when the device is activated, this code is a Deactivation Request, which forces the device through the specified deactivation sequence by setting “dea”=0 in 4 consecutive superframes before ceasing transmission.
- PDN** This power-down command immediately forces the device to a low power state, without sequencing through any of the de-activation states. It should normally only be used after the TP3410 has been put in a known state, e.g., after a DI status indication has been reported.
- AR** Activation Request, which is used after first powering up the device to initiate the specified Activation sequence.
- AC** Activation Complete, which may be used to set “act”=1 in each direction at the completion of activation. In LT mode this is only necessary if Breakpoint 2 is enabled (in Register CR2); in NT mode this is normally required when synchronization on the S/T Interface is confirmed by detection of INFO3.
- RES** RES is the reset command which resets the activation sequencer to the Receive Reset state and resets the DSP coefficients in preparation for a cold-start. This command should be used only in the event of a failed activation attempt (expiry of T4 or T5); it does not affect the Command Registers.

Functional Description (Continued)

- FA0** This command may be used on a fully activated line to force the transmit "act" bit = 0, to indicate loss or denial of 2B + D transparency to the NT (LT state J7). To revert back to sending "act" = 1 use the AC command (with BP2 = 1).
- SEI** S-Interface Error Indication, which should only be used in an NT-1 when loss of received signal is detected (i.e., INFO 0). This command forces the upstream "act" bit (M41) = 0.
- DC*** Deactivation Confirmation. This command may be used as an alternative to PDN, to power-down the device in response to a DI indication. It should not be used prior to the DI indication.

11.3 Activation Indication Register: (READ ONLY)

Byte 2							
7	6	5	4	3	2	1	0
0	0	0	0	C4	C3	C2	C1

Activation Indicators are coded the same as for the Activation Control Register. In Microwire mode only, at each activation status change the four significant bits in this register are sent to the interrupt stack. If multiple interrupt conditions should arise simultaneously, this register has the highest priority and will be read first.

11.4 Activation Status Indicators

- DP/LSD** When the TP3410 is deactivated, either powered up or powered down, the Line Signal Detector sets this indicator if it detects an incoming 10 kHz wake-up tone. If the device is powered down the LSD pin is also pulled low. In NT mode only, this code also functions as a Deactivation Pending indicator when "dea" = 0 is validated.
- SYNC** In LT mode only this indicates when superframe sync is detected, and should be used to stop the external default timer.
- AP** Activation Pending, which is used in NT mode to indicate when superframe sync has been acquired and the BCLK and FS outputs are synchronized to the received line signal. In LT mode, the Line Signal Detector sets this indicator if it detects an incoming 10 kHz wake-up tone.
- AI** This Activation Indication code indicates that the loop is fully activated, ("act" = 1 has been received), and the 2B + D channels are enabled for data transfer. In LT mode, however, if Breakpoint #2 is enabled via CR2, it is necessary to respond to AI with an AC command. This will cause the device to set "act" = 1 in the transmit frame and open the 2B + D channels for data transfer.
- EI** Loss of frame synchronization will set this Error Indicator and inhibit the 2B + D channel data. If a received line signal can still be detected the device will attempt to recover synchronization for up to 480 ms; if this fails it will enter the RESET state and generate a DI. The EI indication is also generated on an activated line if the received "act" bit changes from 1 to 0, indicating loss of transparency at the far-end.

- DI** The Deactivated Indication, which confirms that the loop has been deactivated by means of a Deactivate Request at the LT, and has entered the RESET state. DI* is effective in GCI mode only.
- TIM** In GCI mode only, TIM is an acknowledgment when the device is in the power-down state and receives a PUP command.

11.5 Cold Start and Warm Start

When power is first applied to the device, the first AR command will always initiate a cold-start sequence, which may take up to 15 seconds for complete activation. If the device is subsequently deactivated using the correct procedure, and provided power is maintained uninterrupted in either the power-up or power-down state, the next AR instruction automatically sequences through the warm-start procedure, which normally achieves complete loop activation within 300 ms.

The device includes the specified timers of 15s, 480 ms and 40 ms at the appropriate phases of the activation and deactivation sequences. For applications requiring a default timeout other than 15s the internal timer can be disabled to allow an external timer to be used.

11.6 LT Mode Activation/Deactivation

If activation is initiated by the downstream (NT mode) end with the device either powered up or down, an AP Interrupt condition will be generated on detection of the 10 kHz "wake-up" tone. The Activation Indication Register will show this condition and, if the device is powered down, the LSD pin will be pulled low.

Prior to initiating activation all registers must be programmed appropriately and the device must then be powered up. The use of the commands and status indicators is the same whether activation is initiated locally or from the remote end. An AR command is required to enable the device to proceed with the activation sequence. An internal 15s default timer is also started (in North America the timer value should be 15 seconds if a single loop section is being activated). Please see TP3410 User's Manual for additional information on activation and deactivation.

The sequence continues automatically until superframe synchronization is acquired on the SN3 signal received from the NT. At this point the "act" bit is set = 1 in the downstream direction, and the AI Interrupt is generated in the Activation Indication Register. The loop is then fully activated, with all channels in the data stream available for use.

If activation is not successfully completed before expiry of the 15s timer, the device generates an EI followed by a DI fault indication and ensures that the Activation Sequencer returns to the Full Reset state (J10 to J1) prior to any re-attempt to activate.

For additional control over the activation sequence, a breakpoint state may be enabled at the LT. BP2 will halt the sequence when the loop is fully synchronized, receiving SN3, but the "act" bit is held = 0; this state prevents the S/T Interface from becoming fully activated (the NT1 will maintain INFO2 towards the TEs). An AC command will release this state, allowing activation to be completed. The BP2 bit in Register CR2 controls the enabling of this breakpoint.

Functional Description (Continued)

Deactivation is initiated by writing the DR command in the Activation Control Register, causing "dea" = 0 to be transmitted towards the NT. When the NT ceases to transmit, confirmation of deactivation is provided by a DI Status indicator.

11.7 NT Mode Activation/Deactivation

If activation is initiated by the upstream (LT mode) end with the NT either powered up or down, a Line Signal Detect Interrupt will be generated on detection of the 10 kHz "wake-up" tone. The Activation Indication Register will show this condition and, if the device is powered down, the $\overline{\text{LSD}}$ pin will be pulled low. To proceed with the activation sequence, all registers must be programmed appropriately (see Note 1) and the device must then be powered up. The use of the commands and status indicators is the same whether activation is initiated locally or in response to the Line Signal Detect Interrupt. An AR command will enable the device to automatically proceed with the activation sequence. An internal 15s default timer is also started (in North America the timer value should be 15 seconds if a single DSL section is being activated). See TP3410 User's Manual for additional information on activation and deactivation.

The sequence continues until the NT acquires superframe synchronization on the SL2 signal received from the LT. At this point an AP Interrupt is generated and the device starts transmitting SN3 with "act" = 0. To complete activation, normally when the NT has detected INFO3 signals from a TE, the "act" bit must be set = 1 by writing the AC command to the Activation Control Register. An AI Status indication will finally be generated by the device when the loop is fully synchronized and receiving SL3 frames with "act" = 1; this is automatically validated 3 times regardless of the options selected in Register OPR. The loop is then fully activated, with all channels in the data stream available for use.

If activation is not successfully completed before expiry of the 15s timer, the device generates an EI followed by a DI fault indication and ensures that the Activation Sequencer returns to the Full Reset state prior to any re-attempt to activate.

Deactivation is normally initiated by the LT, which sets "dea" = 0 towards the NT. The TP3410 in NT mode will detect and validate this bit 3 times prior to setting the DP interrupt (regardless of the options selected in OPR). Transmission will cease when it is detected that the far-end signal has ceased, after which the device enters the Reset state and generates a DI Interrupt to indicate that deactivation is complete.

Note 1: The M45 bit conveys an indication of whether the NT can support a warm-start procedure (the "cso" bit). Since the TP3410 automatically supports both cold and warm start, set "cso" = 0.

Applications Information

LINE INTERFACE CIRCUIT

The transmission performance obtainable from a TP3410 U-interface is strongly dependent on the line interface circuit (LIC) design. Two designs, shown in *Figures 9* and *10*, are recommended. They should be adhered to strictly. The channel response and insertion losses of these circuits have been carefully designed as an integral part of the overall signal processing system to ensure the performance re-

quirements are met under all specified loop conditions. Deviations from these designs may result in sub-optimal performance or even total failure of the system to operate on some types of loops.

The standard LIC (*Figure 9*) has the advantage of backwards compatibility with Rev. 2.x devices together with a generally lower component sensitivity. The TP3410 must be configured to select the chosen LIC. For the standard LIC, set saif = 1 in register CR4. This is the default configuration.

The alternative LIC (*Figure 10*) does not use lineside surge limiting resistors and so has advantages where line powering is required. To configure the TP3410 for the alternative LIC, set saif = 0.

Transformer parameters form a major part of the LIC. Two of the most important are:

Turns Ratio:

$$\begin{aligned} \text{Chip side (primary): Line side (secondary)} \\ = 1:1.5 \end{aligned}$$

Secondary inductance:

$$L_S = 27 \text{ mH} \pm 5\% \text{ at } 1 \text{ kHz}$$

For more details on transformer specification and for a list of qualified vendors, see the TP3410 User's Manual, AN-913.

BOARD LAYOUT

While the pins of the TP3410 are well protected against electrical misuse, it is recommended that the standard CMOS practice of applying GND to the device before any other connections are made should always be followed. In applications where the printed circuit card may be plugged into a hot socket with power and clocks already present, an extra long ground pin on the connector should be used.

Great care must be taken in the layout of the printed circuit board in order to preserve the high transmission performance of the TP3410. To maximize performance do not use the philosophy of separating analog and digital grounds on the board. The 3 GND pins should be connected together as close as possible to the pins, and the 2 V_{CC} pins should be strapped together. All ground connections to each device should meet at a common point as close as possible to the 3 GND pins in order to prevent the interaction of ground return currents flowing through a common bus impedance. A decoupling capacitor of 0.1 μF should be connected from this common point to the V_{CC} pins. Taking care with the pcb layout in the following ways will also help prevent noise injection into the receiver front-end and maximize the transmission performance:

1. Keep the crystal oscillator components away from the receiver inputs and use a ground plane for shielding around these components.
2. Keep the connections between the device and the components on the $\text{Li} \pm$ inputs short.
3. Keep the connections between the device and transformer short.

ADDITIONAL INFORMATION

For more in-depth information on a variety of applications, the TP3410 Users Manual, AN-913, is a comprehensive guide to the hardware and software required to meet the ANSI interface specification.

Applications Information (Continued)

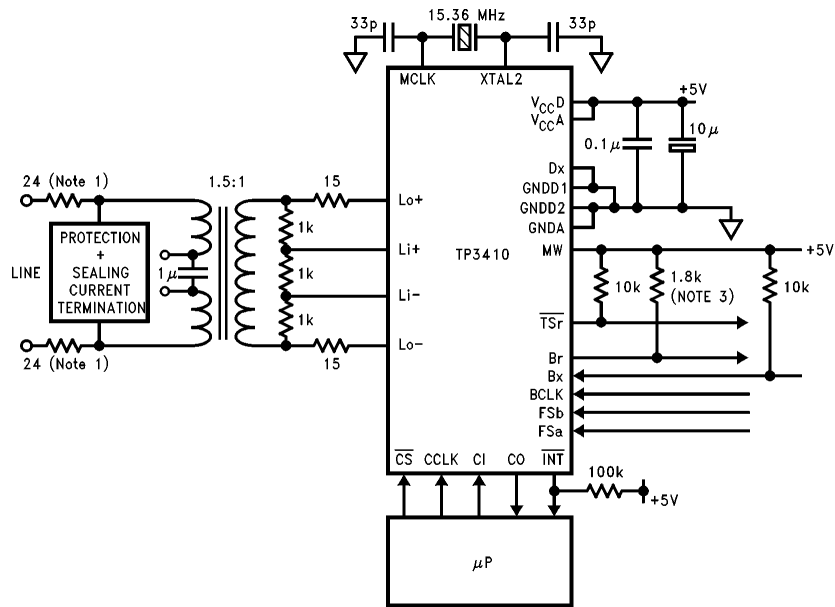

TL/H/9151-19

Note 1: 0.1% matching may be required to meet the longitudinal balance specification, depending on the Longitudinal impedance to ground of the line interface. The 15Ω and 1k resistors in the line interface circuit should be 1% tolerance, and the capacitors should be 10%.

Note 2: An alternative circuit which removes the 24Ω surge-limiting resistors is shown in *Figure 10*.

Note 3: Only necessary in GCI Mode.

Note 4: See AN-913 for further information about the line circuit.

FIGURE 9. Typical Application in Microwire Mode

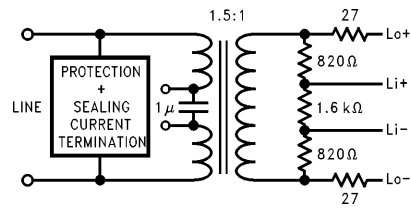

TL/H/9151-20

Note 1: All resistors 1% tolerance, and capacitors 10%.

Note 2: This circuit provides no surge current limiting for the transformer.

Note 3: See AN-913 for further information about the line circuit.

FIGURE 10. Alternative Interface Circuit

Absolute Maximum Ratings

If Military/Aerospace specified devices are required, please contact the National Semiconductor Sales Office/Distributors for availability and specifications.

V_{CC} to GND	7V
Voltage at Li, Lo	$V_{CC} + 1V$ to GND $- 1V$
Voltage at Any Digital Input	$V_{CC} + 1V$ to GND $- 1V$

Storage Temperature Range	-65°C to $+150^{\circ}\text{C}$
Current at Lo	$\pm 200 \mu\text{A}$
Current at Any Digital Output	$\pm 50 \text{mA}$
Lead Temperature (Soldering, 10 seconds)	300°C
ESD (Human Body Model) J	TBD
θ_{JA} (Package Number J28A)	40°C/W

Electrical Characteristics

Unless otherwise noted, limits printed in **bold** characters are electrical testing limits at $V_{CC} = 5.0V$ and $T_A = 25^{\circ}\text{C}$. All other limits are design goals for $V_{CC} = 5.0V \pm 5\%$ and $T_J = 0^{\circ}\text{C}$ to 90°C (refer to Application Note AN-336). This data sheet is still preliminary and parameter limits are not indicative of characterization data with respect to power supply or temperature variations. Please contact your National Semiconductor Sales Office for the most current product information.

Symbol	Parameter	Conditions	Limits			Units
			Min	Typ	Max	
DIGITAL INTERFACES						
V_{IL}	Input Low Voltage	All Digital Inputs			0.7	V
V_{IH}	Input High Voltage	All Digital Inputs	2.2			V
V_{ILX}	Input Low Voltage	MCLK/XTAL Input			0.5	V
V_{IHx}	Input High Voltage	MCLK/XTAL Input	$V_{CC} - 0.5$			V
V_{OL}	Output Low Voltage	Br, $I_O = 3.2 \text{mA}$ All Other Digital Outputs, $I_O = 1 \text{mA}$			0.4	V
V_{OH}	Output High Voltage	Br, $I_O = 3.2 \text{mA}$ All Other Digital Outputs, $I_O = -1 \text{mA}$ All Outputs, $I_O = -100 \mu\text{A}$	2.4 2.4 $V_{CC} - 0.5$			V V V
I_I	Input Current	Any Digital Input, $\text{GND} < V_{IN} < V_{CC}$	-10		10	μA
I_{OZ}	Output Current in High Impedance State (TRI-STATE®)	Br, $\overline{\text{INT}}$, $\overline{\text{LSD}}$, CO, Dr $\text{GND} < V_{OUT} < V_{CC}$	-10		10	μA
LINE INTERFACES						
R_{Li}	Differential Input Resistance	$\text{GND} < \text{Li}+, \text{Li}- < V_{CC}$	30			$\text{k}\Omega$
$CLLo$	Load Capacitance	Between $\text{Lo}+$ and $\text{Lo}-$ Connected Externally			200	pF
V_{OS}	Differential Output Offset Voltage at $\text{Lo}+$, $\text{Lo}-$		-100		+100	mV
POWER DISSIPATION						
I_{CC0}	Power Down Current	All Outputs Open-Circuit		4		mA
I_{CC1}	Power Up Current	Device Activated		65		mA
TRANSMISSION PERFORMANCE						
	Transmit Pulse Amplitude	$R_L = 115\Omega$ between $\text{Lo}+$ and $\text{Lo}-$ (Note 2)		± 3.5		Vpk
	Transmit Pulse Linearity		36	60		dB
	Input Pulse Amplitude	Differential between $\text{Li}+$ and $\text{Li}-$	± 4		± 800	mVpk

Note 1: GND refers to GND, GNDD1 and GNDD2 commoned together; V_{CC} refers to V_{CCA} and V_{CCD} commoned together.

Note 2: In the circuits shown in Figures 9 and 10, terminated in 135Ω , this is equivalent to $\pm 2.5V$ for isolated pulses of the outer levels. Selection of this test mode is described in the TP3410 Users Manual AN-913.

Timing Characteristics

Symbol	Parameter	Conditions	Min	Typ	Max	Units
FMCK	Master Clock Frequency Master Clock Tolerance	Including Temperature, Aging, Etc.	-100	15.36	+100	MHz ppm
	MCLK/XTAL Input Clock Jitter	External Clock Source			50	ns pk-pk
tMH, tML	Clock Pulse Width Hi & Low for MCLK	$V_{IH} = V_{CC} - 0.5V$ $V_{IL} = 0.5V$	20			ns
tMR, tMF	Rise and Fall Time of MCLK	Used as a Logic Input			10	ns
DIGITAL INTERFACE (Figures 11, 12 and 13)						
FBCLK	Frequency of BCLK	Formats 1, 2 and 3 GCI and Format 4	256 512		4096 6144	kHz kHz
tWBH	Period of BCLK High	Measured from V_{IH} to V_{IH} (Input)	25			ns
tWBL	Period of BCLK Low	Measured from V_{IL} to V_{IL} (Input)	25			ns
tRB	Rise Time of BCLK	Measured from V_{IL} to V_{IH} (Input)			15	ns
tFB	Fall Time of BCLK	Measured from V_{IH} to V_{IL} (Input)			15	ns
tSFB	Setup Time, FS High to BCLK Low	DSI or GCI Slave Only	50			ns
tHBF	Hold Time, BCLK Low to FS, High or Low	DSI or GCI Slave Only	25			ns
tDBF	Delay Time, BCLK High to FS _a and FS _b Transitions	DSI or GCI Master Only			50	ns
tDBD	Delay Time, BCLK High to Data Valid	All Modes Load = 150 pF Plus 2 LSTTL Loads			80	ns
tDBZ	Delay Time, BCLK High to Br, Dr Disabled	All Modes			55	ns
tDBT	Delay Time, BCLK High to \overline{TSr} Low if FS High, or FS High to \overline{TSr} Low if BCLK High	Load = 100 pF Plus 2 LSTTL Loads			55	ns
tZBT	TRI-STATE Time, BCLK Low to \overline{TSr} High				55	ns
tDFD	Delay Time, FS High to Data Valid	Load = 150 pF Plus 2 LSTTL Loads, Applies if FS Rises Later than BCLK Rising Edge in Non-Delayed Data Mode Only			80	ns
tSDB	Setup Time, Data Valid to BCLK Low	All Modes	0			ns
tHBD	Hold Time, BCLK Low to Data Invalid	All Modes	25			ns

Timing Characteristics (Continued)

Symbol	Parameter	Conditions	Min	Typ	Max	Units
MICROWIRE CONTROL INTERFACE (see Figure 14)						
tCH	CCLK High Duration		50			ns
tCL	CCLK Low Duration		50			ns
tSIC	Setup Time, CI Valid to CCLK High		25			ns
tHCI	Hold Time, CCLK High to CI Invalid		25			ns
tSSC	Setup Time from \overline{CS} Low to CCLK High		50			ns
tDCSO	Delay Time from \overline{CS} Low to CO Valid	Byte 1, Bit C7 Only			50	ns
tDCO	Delay Time from CCLK Low to CO Data Valid	Load = 50 pF Plus 2 LSTTL Inputs			50	ns
tDCZ	Delay Time from \overline{CS} High to CO TRI-STATE				50	ns
tSCSC1	Setup Time, \overline{CS} Low to CCLK Edge High		50			ns
tHCSC1	Hold Time, \overline{CS} High to CCLK Edge Low		50			ns
tHCSC2	Hold Time, \overline{CS} High to CCLK Edge High		12			ns
tHCSC3	Hold Time, CCLK Low to \overline{CS} Transition		12			ns
tCSH	Duration of \overline{CS} High		200			ns
tDCI	Delay Time CCLK High to \overline{INT} High-Impedance				50	ns
D PORT IN 16 kHz MODE (Figure 4)						
tSDXC	Setup Time, Dx to DCLK		65			ns
tHCDX	Hold Time, DCLK to Dx		0			ns
tDCDR	Delay Time, DCLK to Dr	Load = 50 pF Plus 2 LSTTL Inputs			80	ns

Timing Diagrams

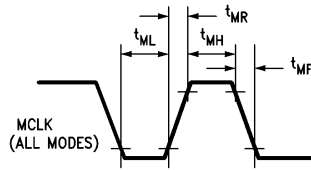

TL/H/9151-28

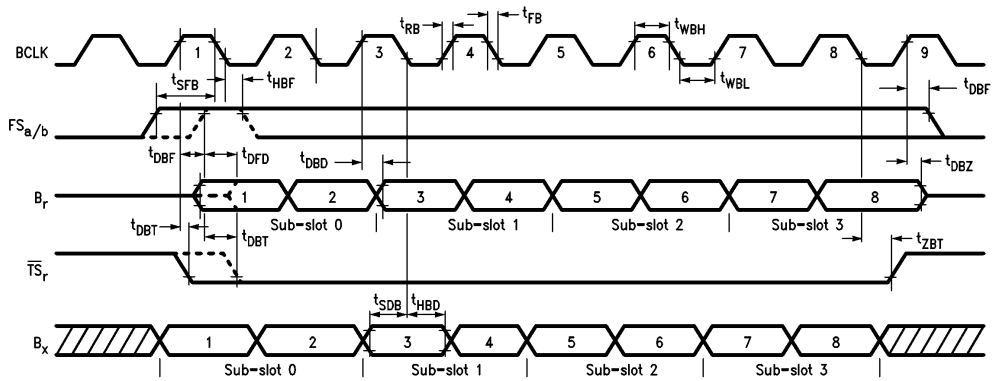

TL/H/9151-21

FIGURE 11. Non-Delayed Data Timing Mode (Formats 1 and 3)

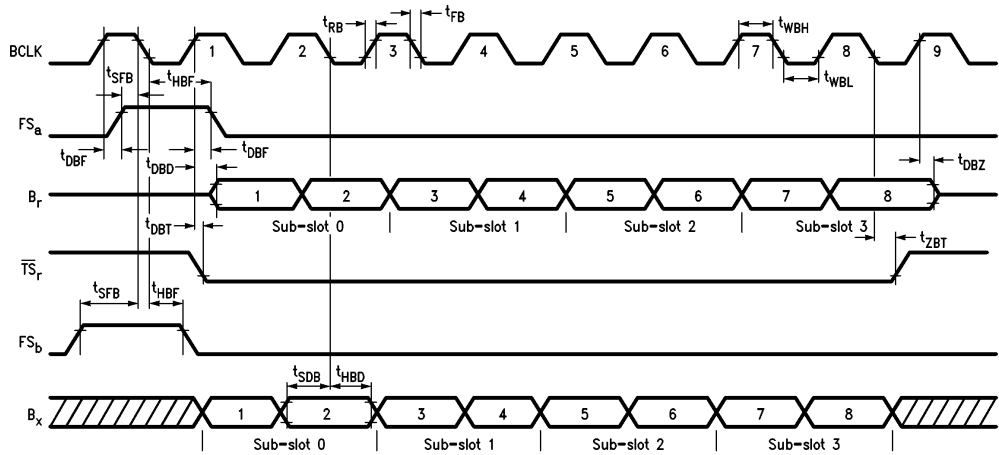

TL/H/9151-22

FIGURE 12. Delayed Data Timing Mode (Formats 1, 2 and 3)
(Shown with TS0 Selected)

Timing Diagrams (Continued)

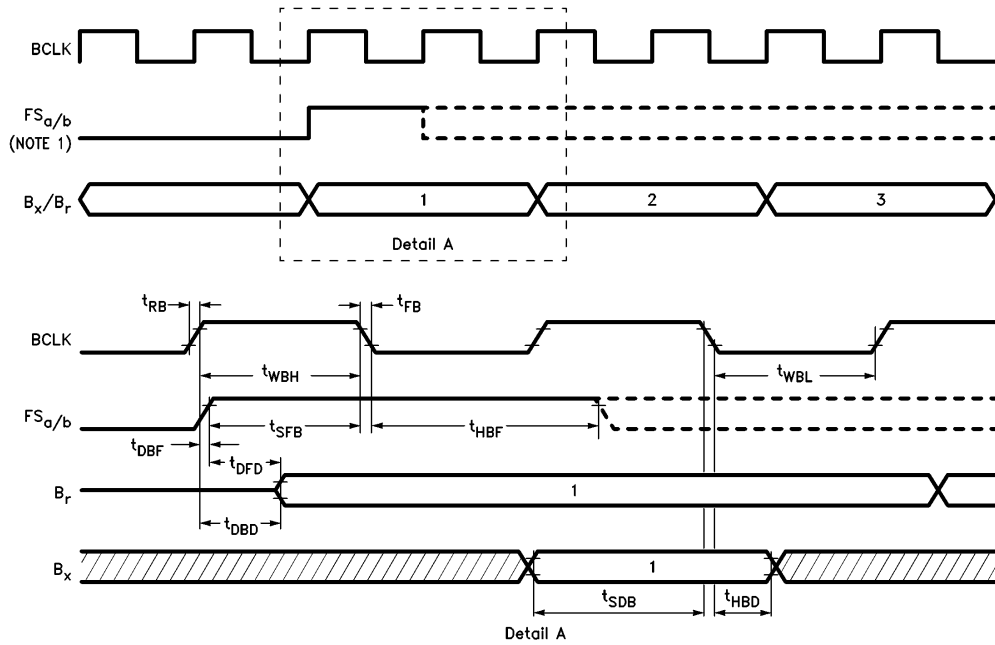

TL/H/9151-23

Note 1: As an output (GCI Master) FS_a is high for 8 bit intervals (16 BCLK cycles). As an input (GCI Slave) FS_a must be high for ≥ 1 BCLK cycle.

FIGURE 13. GCI and Format 4 Timing

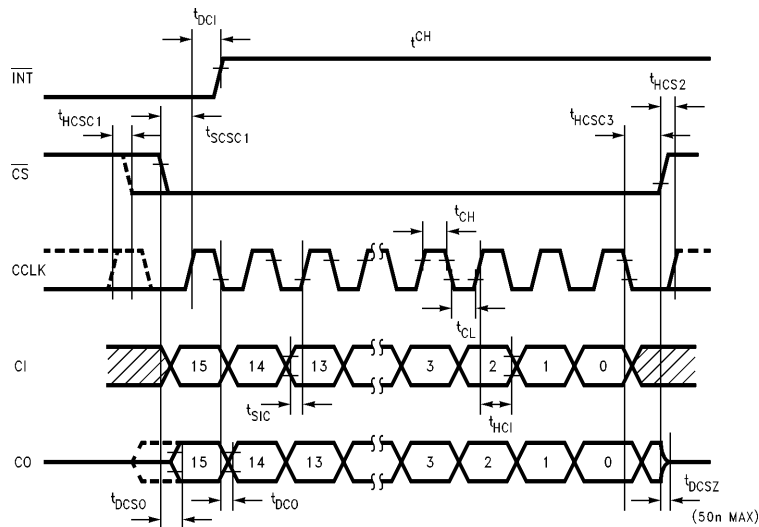

TL/H/9151-24

FIGURE 14a. TP3410 Enhanced MICROWIRE Control Port Timing

Timing Diagrams (Continued)

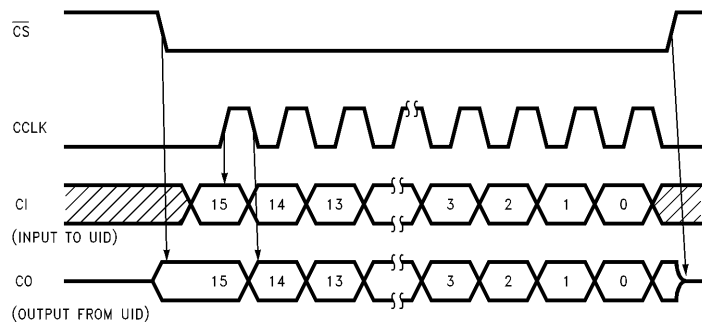

TL/H/9151-29

FIGURE 14b. TP3410 Normal MICROWIRE CLOCK Format

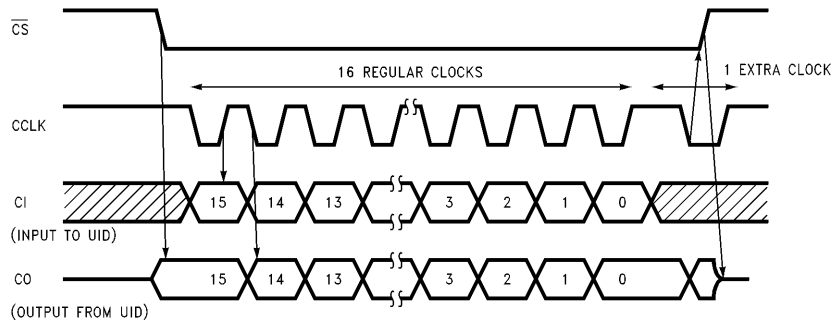

TL/H/9151-30

FIGURE 14c. TP3410 Alternate MICROWIRE CLOCK Format

Looking for pricing, stock, or lifecycle information?

Click below to explore more details on WIN SOURCE:

 [View TP3410J304-X on WIN SOURCE](#)

 [Texas Instruments](#) Information

Optimize Your Supply Chain with WIN SOURCE Solutions

-  Global Sourcing Solution
-  Obsolete Management
-  Cost Control Management
-  Shortage Management
-  Alternative Solution
-  Excess Inventory Management