



**THE DATASHEET OF
TLE4913HTSA1**



Features

- Micro power design
- 2.4 V to 5.5 V battery operation
- High sensitivity and high stability of the magnetic switching points
- High resistance to mechanical stress
- Digital output signal
- Switching for both poles of a magnet (omnipolar)
- Not suitable for automotive application

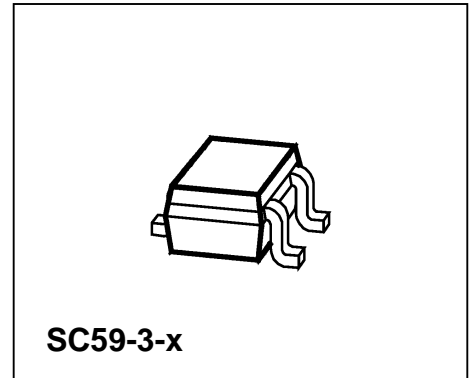

Functional Description

The TLE4913 is an Integrated Hall-Effect Sensor designed specifically to meet the requirements of low-power devices. e.g. as an On/Off switch in Cellular Flip-Phones, with battery operating voltages of 2.4V – 5.5V.

Precise magnetic switching points and high temperature stability are achieved through the unique design of the internal circuit.

An onboard clock scheme is used to reduce the average operating current of the IC.

During the operate phase the IC compares the actual magnetic field detected with the internally compensated switching points. The output Q is switched at the end of each operating phase.

During the Stand-by phase the output stage is latched and the current consumption of the device reduced to some μA .

The IC switching behaviour is Omnipolar, i.e. it can be switched on with either the North or South pole of a magnet.

Type	Marking	Ordering Code	Package
TLE 4913	13s 013	SP000013490	SC 59-3-x

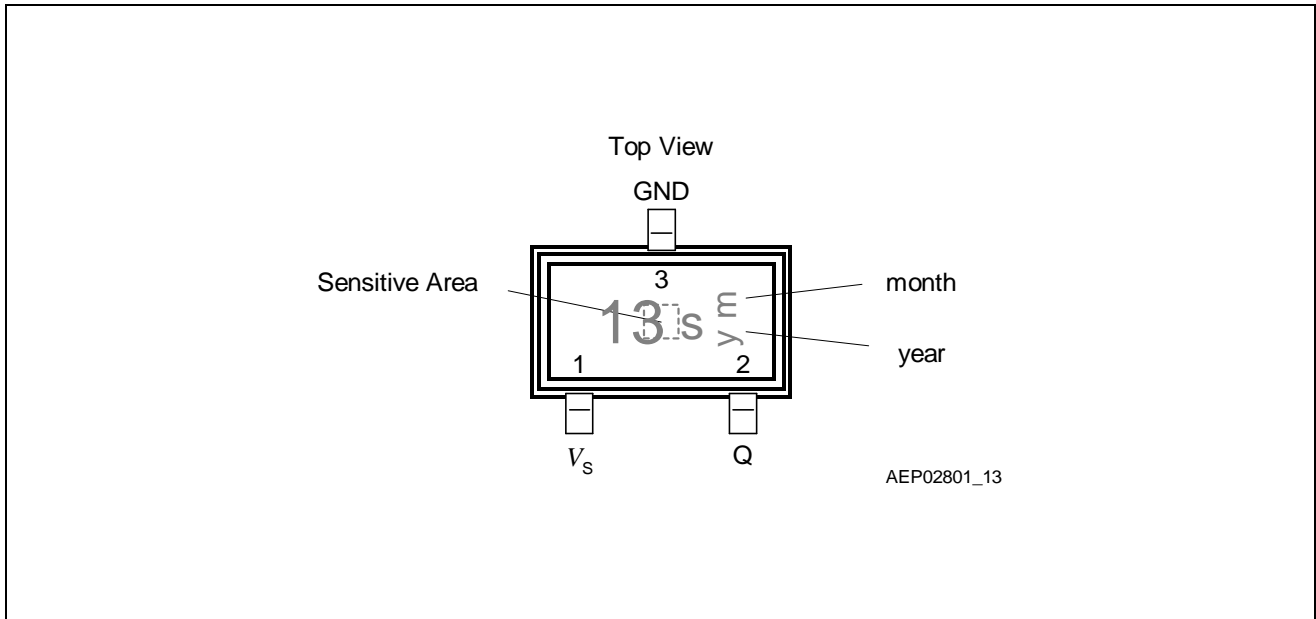

Figure 1 Pin Configuration (top view)

Pin Definitions and Functions

Pin	Symbol	Function
1	V_s	Supply Voltage
2	Q	Open Drain Input
3	Gnd	Ground

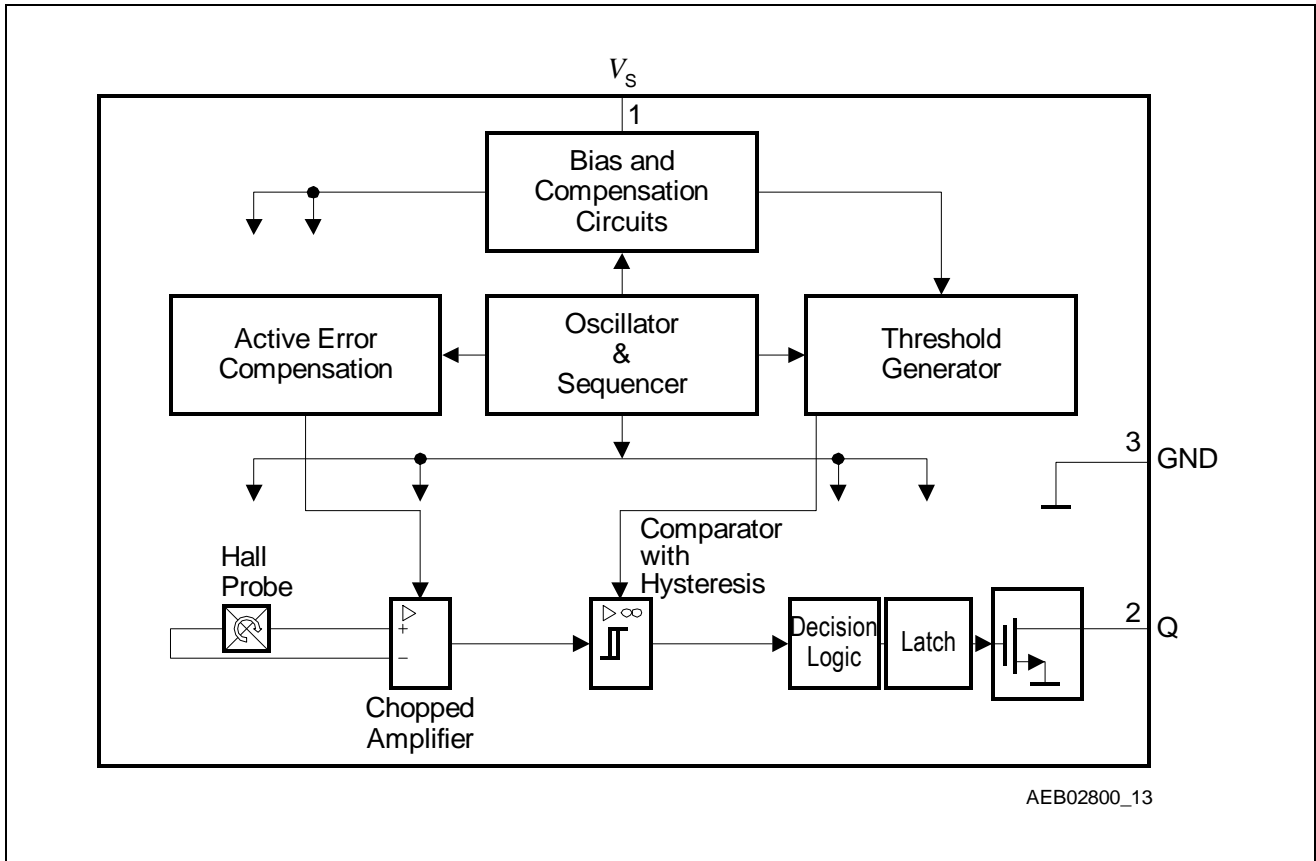

Figure 2 Block Diagram

Circuit Description

The Low Power Hall IC Switch comprises a Hall probe, bias generator, compensation circuits, oscillator, output latch and an n-channel open drain output transistor.

The bias generator provides currents for the Hall probe and the active circuits. Compensation circuits stabilize the temperature behavior and reduce technology variations.

The Active Error Compensation rejects offsets in signal stages and the influence of mechanical stress to the Hall probe caused by molding and soldering processes and other thermal stresses in the package. This chopper technique together with the threshold generator and the comparator ensures high accurate magnetic switching points.

Very low power consumption is achieved with a timing scheme controlled by an oscillator and a sequencer. This circuitry activates the sensor for 50 μs (typical operating time) sets the output state after sequential questioning of the switch points and latches it with the beginning of the following standby phase (max. 200 ms). In the standby phase the average current is reduced to typical 4 μA . Because of the long standby time compared to the operating time the overall averaged current is only slightly higher than the standby current.

The output transistor can sink up to 1 mA with a maximal saturation voltage V_{QSAT} .

Absolute Maximum Ratings

Parameter	Symbol	Limit Values		Unit	Notes
		min.	max.		
Supply Voltage	V_S	- 0.3	5.5	V	
Supply Current	I_S	- 1	2.5	mA	
Output Voltage	V_Q	- 0.3	5.5	V	
Output Current	I_Q	- 1	2	mA	
Junction temperature	T_j	- 40	150	°C	
Storage temperature	T_S	- 40	150	°C	
Magnetic Flux Density	B	-	unlimited	mT	
Thermal Resistance P-SC59-3-x	$R_{th JA}$	-	35	K/W	

Note: Stresses above those listed here may cause permanent damage to the device. Exposure to absolute maximum rating conditions for extended periods may affect device reliability.

ESD Protection

Human Body Model (HBM) tests according to:
EOS/ESD Association Standard S5.1-1993 and Mil. Std. 883D method 3015.7

Parameter	Symbol	Limit Values		Unit	Notes
		Min.	Max.		
ESD Voltage	V_{ESD}		± 4	kV	$R = 1.5 \text{ k}\Omega$, $C = 100 \text{ pF}$; $T = 25 \text{ }^\circ\text{C}$

Operating Range

Parameter	Symbol	Limit Values			Unit	Notes
		Min.	typ.	max.		
Supply voltage	V_S	2.4	2.7	5.5	V	¹⁾
Output voltage	V_Q	- 0.3	2.7	5.5	V	
Ambient Temperature	T_A	- 40	25	85	°C	

¹⁾ A Ceramic Bypass Capacitor of 100 nF at V_S to GND is highly recommended.

AC/DC Characteristics

Parameter	Symbol	Limit Values			Unit	Notes
		Min.	typ.	Max.		
Averaged Supply Current	I_{SAVG}	1	4	20	μ A	
Averaged Supply Current during Operating Time	I_{SOPAVG}	0.5	1.1	2.5	mA	
Transient Peak Supply Current during Operating Time	I_{SOPT}	-	-	2.5	mA	$t < 100$ ns
Supply Current during Standby Time	I_{SSTB}	1	3.5	20	μ A	
Output Saturation Voltage	V_{QSAT}	-	0.13	0.4	V	$I_Q = 1$ mA
Output Leakage Current	I_{QLEAK}	-	0.01	1	μ A	
Output Rise Time	t_r	-	0.5	1	μ s	$R_L = 2.7$ k Ω ; $C_L = 10$ pF
Output Fall Time	t_f	-	0.1	1	μ s	$R_L = 2.7$ k Ω ; $C_L = 10$ pF
Operating Time	t_{op}	15	50	93 ^{1) 2)}	μ s	
Standby Time	t_{stb}	-	130	240 ³⁾	ms	
Duty Cycle	t_{op} / t_{stb}	-	0.039	-	%	
Start-up Time of IC	t_{stu}	-	6	12	μ s	⁴⁾

¹⁾ for $V_S=3.5$ V the max. Operating Time $t_{op\ max} = 85\mu$ s

²⁾ includes the Start-up Time t_{stu}

³⁾ for $V_S=3.5$ V the max. Standby Time $t_{stb\ max} = 220$ ms

⁴⁾ initial power on time. V_S must be applied in this time (typ. 6 μ s to max. 12 μ s) to get already a valid output state after the first operating phase (typ. 56 μ s). For rise times of $V_S > 12\mu$ s, the output state is valid after the second operating phase (includes one standby phase), e.g. happens only when the battery in flip phones is changed.

Magnetic Characteristics

Parameter	Symbol	Limit Values			Unit	Notes
		min.	typ.	max.		
Operate Points (Output on)	B _{OPS}	2	3.5	5	mT	1)
	B _{OPN}	- 5	- 3.5	- 2	mT	
Release Points (Output off)	B _{RPS}	1,2	2.7	4.2	mT	1)
	B _{RPN}	- 4.2	- 2.6	- 1,2	mT	
Hysteresis	B _{HYS}	0.2	0.8	1,6	mT	

¹⁾ Positive magnetic fields are related to the approach of a magnetic south pole to the branded side of package

Note: The listed AC/DC and magnetic characteristics are ensured over the operating range of the integrated circuit. Typical characteristics specify mean values expected over the production spread. If not other specified, typical characteristics apply at $T_j = 25\text{ °C}$ and $V_S = 2.7\text{ V}$

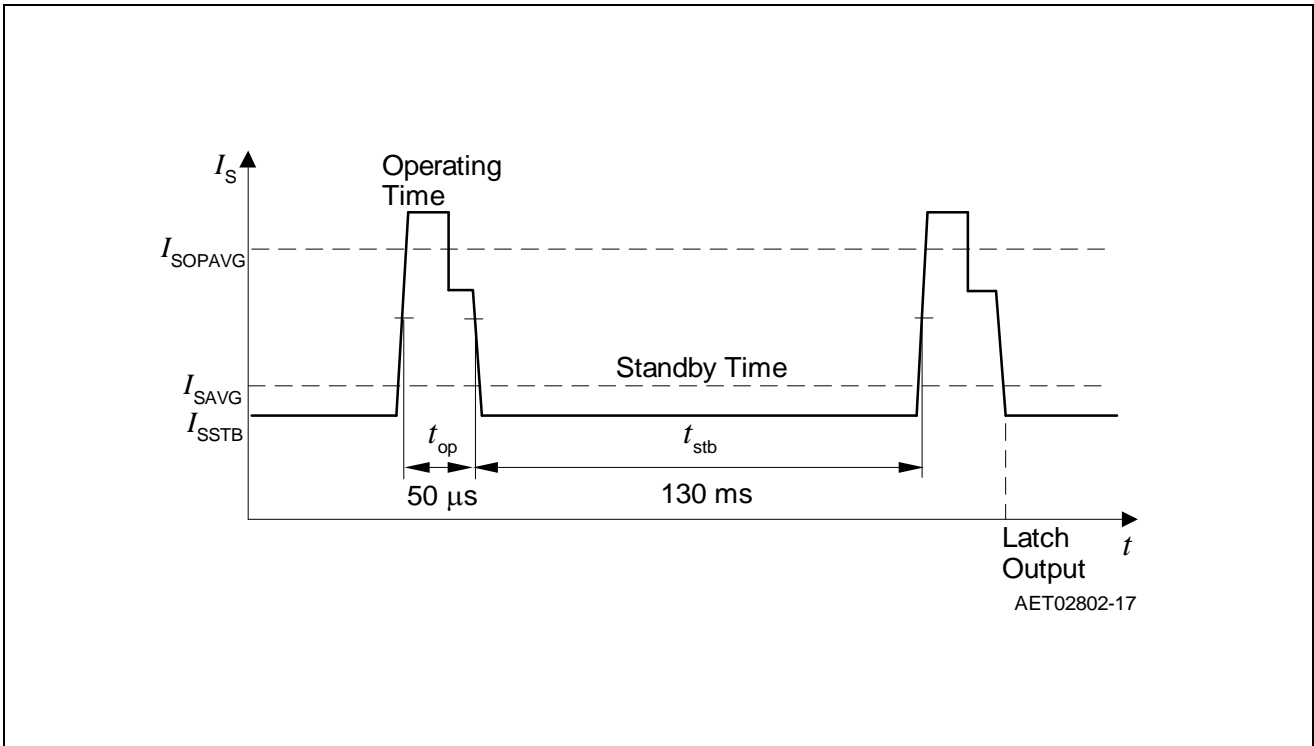

Figure 3 Timing Diagram

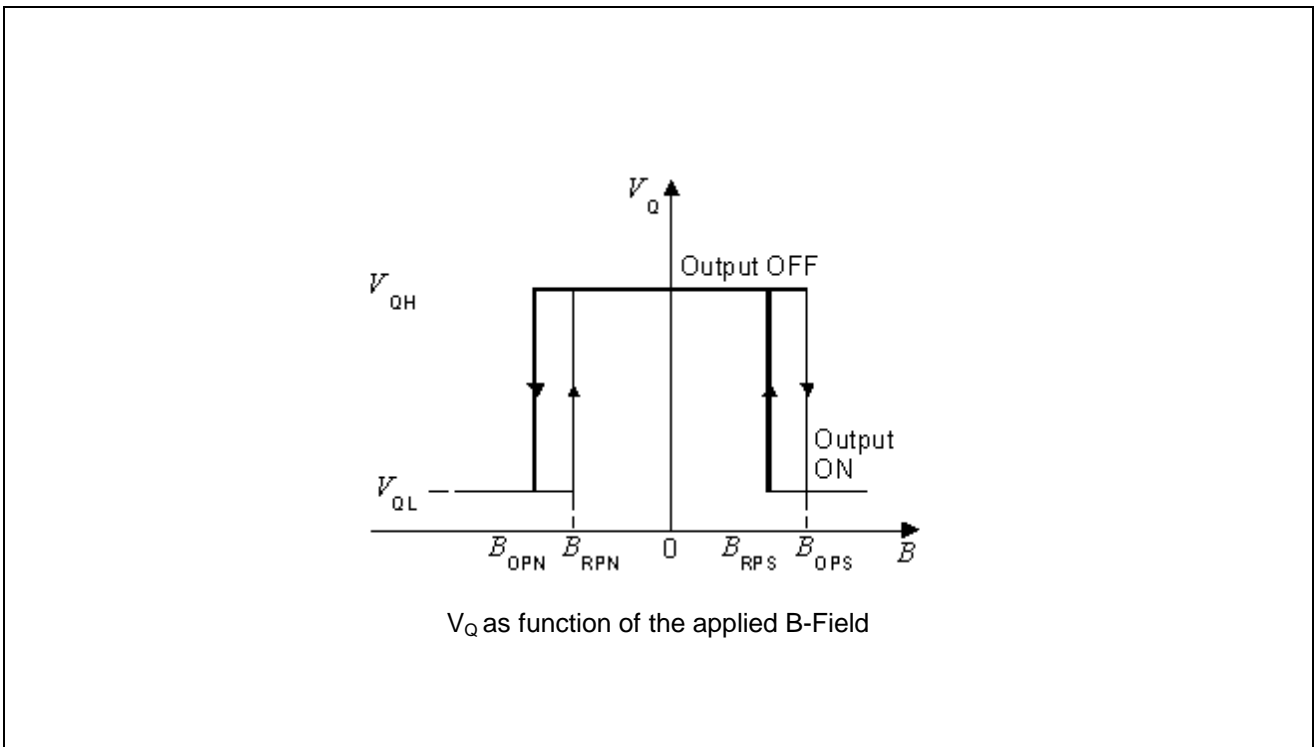
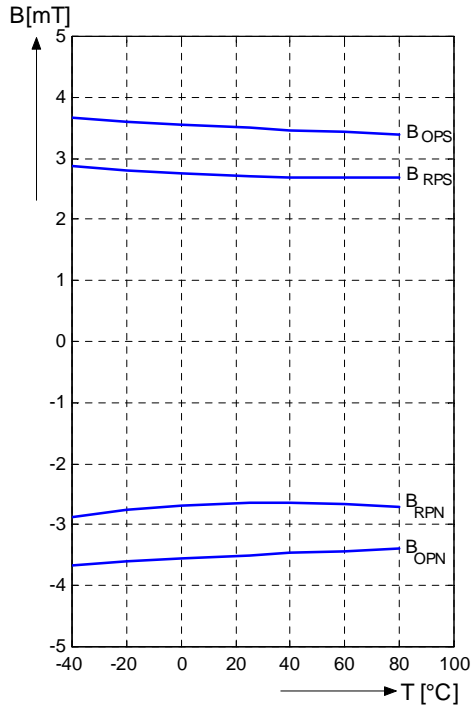

Figure 4 Output – Signal TLE 4913

All curves reflect typical values at the given parameters for T_A in $^{\circ}\text{C}$ and V_S in V.

Magnetic Switching Points versus Temperature ($V_S=2.7\text{V}$)



Magnetic Switching Points versus Supply Voltage V_S ($T_A=20^{\circ}\text{C}$)

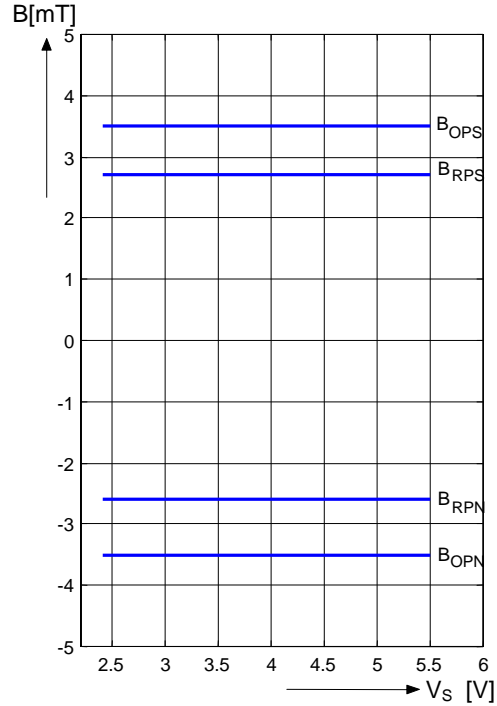

Supply current I_{SOPAVG} during Operating Time versus Temperature ($V_S=2.7\text{V}$)

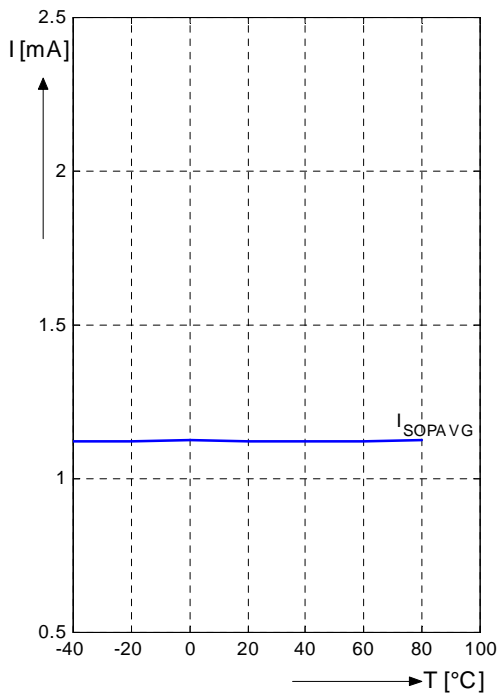

Supply current I_{SOPAVG} during Operating Time versus Supply Voltage V_S ($T_A=20^{\circ}\text{C}$)

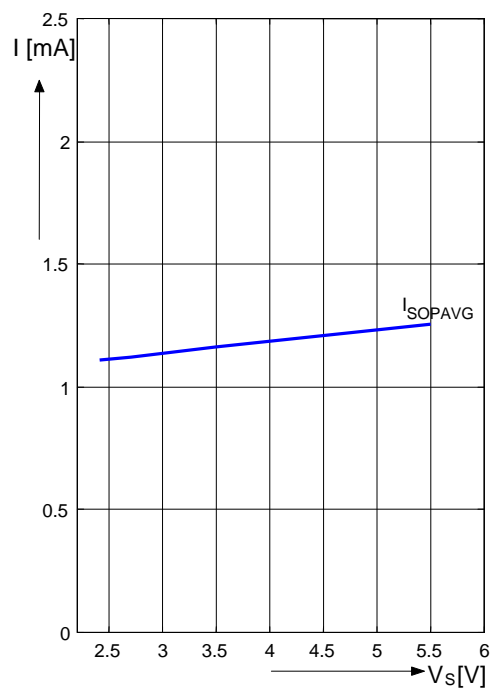

**Supply current I_{SSTB} during Standby
Time versus Temperature ($V_S=2.7V$)**

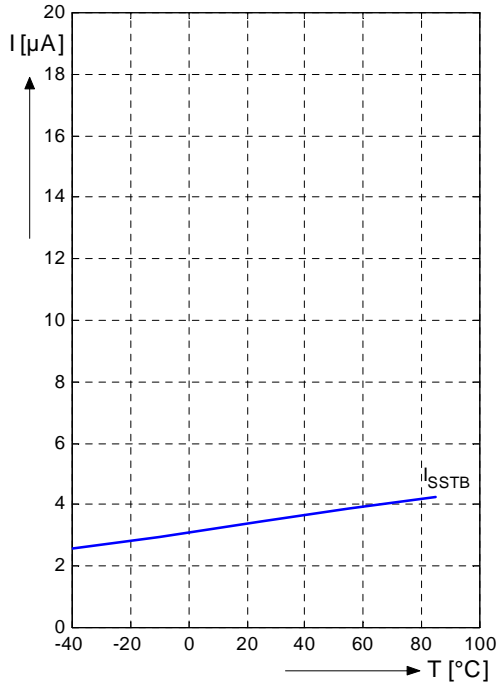

**Supply current I_{SSTB} during Standby
Time versus Supply Voltage V_S ($T_A=20^\circ C$)**

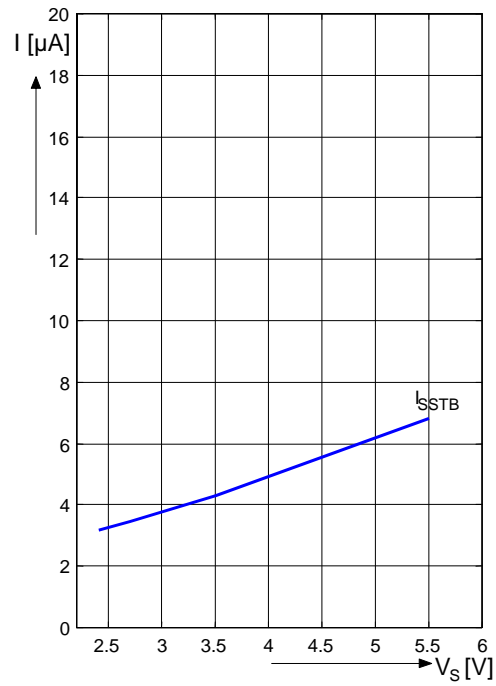

**Output Saturation voltage V_{QSAT}
versus Temperature ($I_Q=1mA$)**

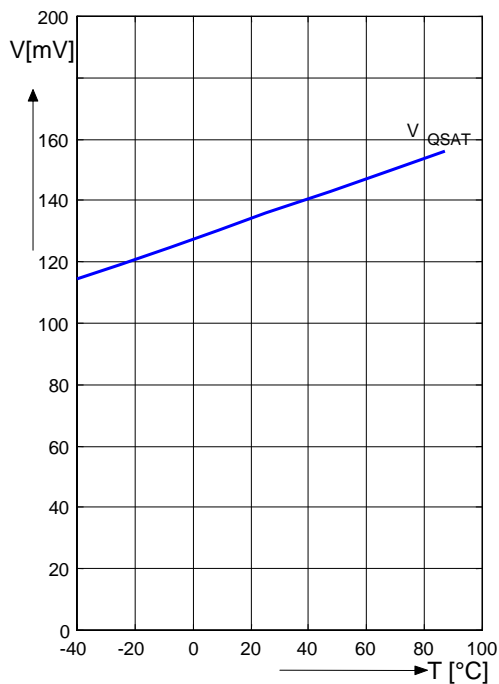

**Standby Time t_{stb} versus Temperature
($V_S = 2.7V$)**

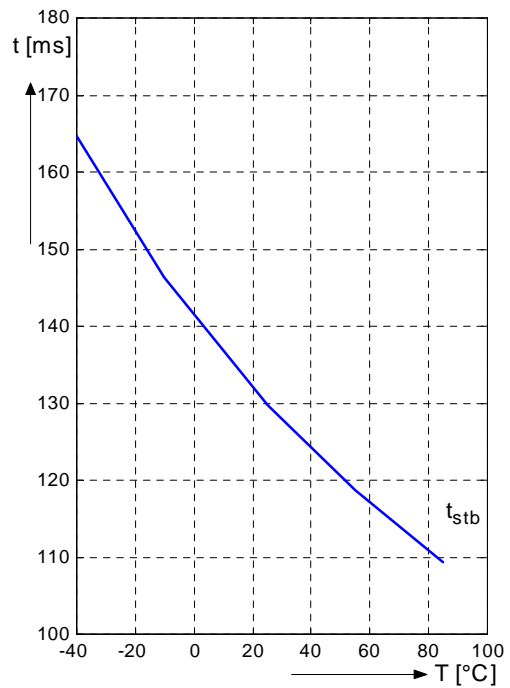

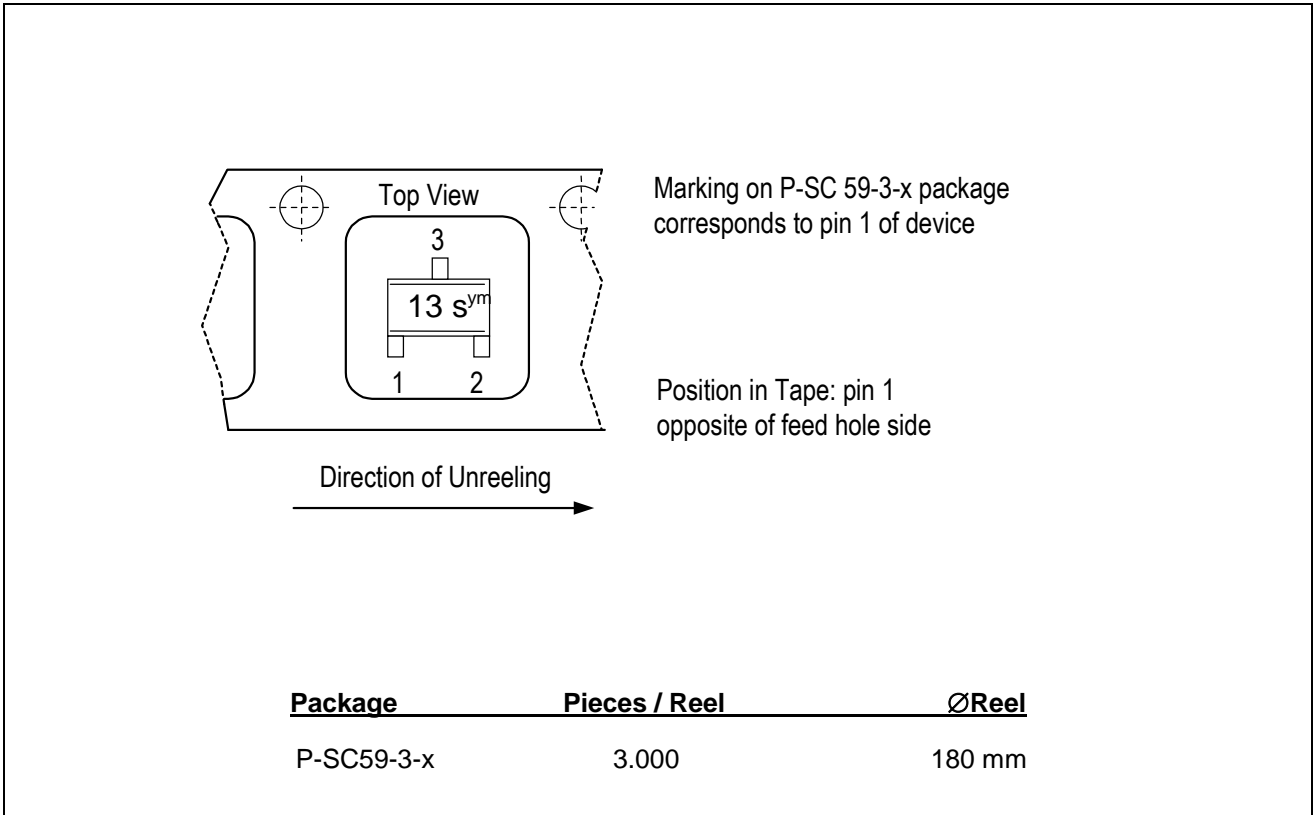

Figure 5 Marking and Tape Loading Orientation

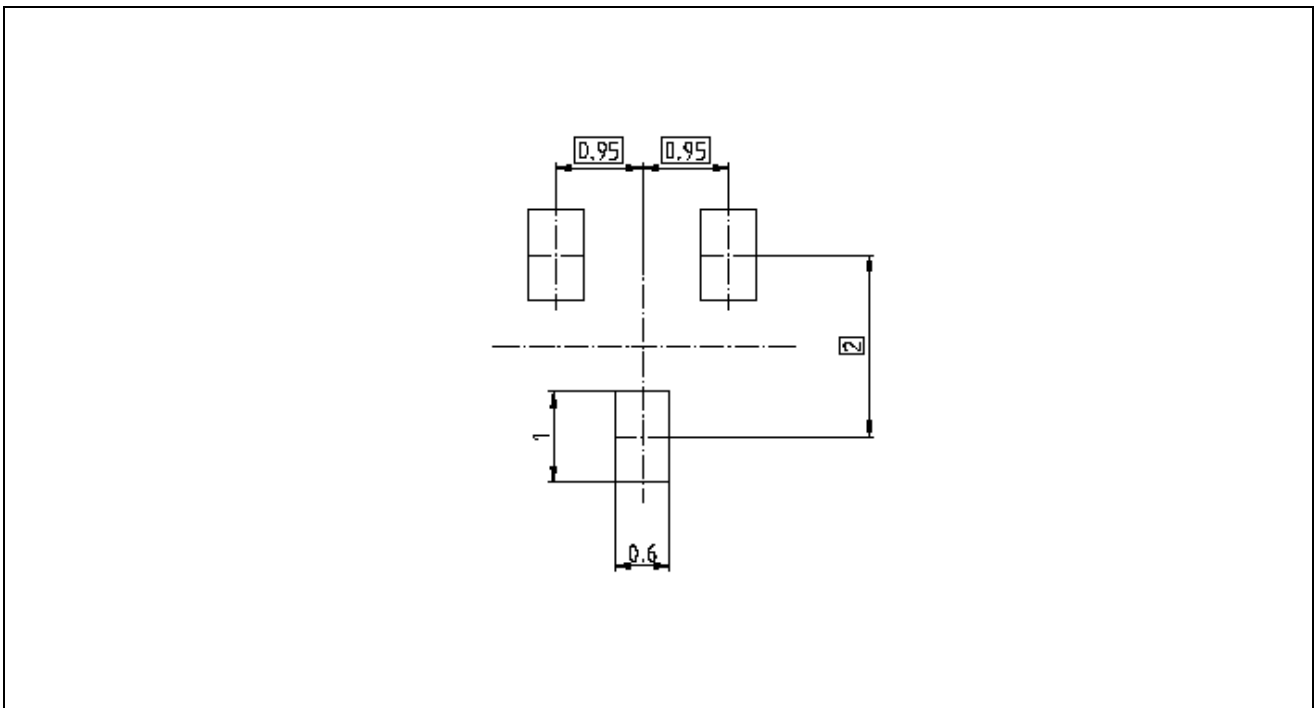

Figure 6 Foot Print Reflow Soldering

TLE4913		V 2.3
Revision History: 2019-05-14		
Previous Version: 2003-07-16 and 2004-03-09		
Page	Subjects (major changes since last revision)	
4	ESD Level adapted to ± 4 kV	
1	Change of Ordering Code from Q62705K 619 into SP000013490	

For questions on technology, delivery and prices please contact the Infineon Technologies Offices in Germany or the Infineon Technologies Companies and Representatives worldwide: see our webpage at <http://www.infineon.com>

We Listen to Your Comments

Any information within this document that you feel is wrong, unclear or missing at all? Your feedback will help us to continuously improve the quality of this document. Please send your proposal (including a reference to this document) to:
feedback.sensors@infineon.com

Edition 2002-08-22
 Published by Infineon Technologies AG
 St.-Martin-Strasse 53
 D-81541 München
 © Infineon Technologies AG 2000
 All Rights Reserved.

Attention please!

The information herein is given to describe certain components and shall not be considered as warranted characteristics. Terms of delivery and rights to technical change reserved.
 We hereby disclaim any and all warranties, including but not limited to warranties of non-infringement, regarding circuits, descriptions and charts stated herein.
 Infineon Technologies is an approved CECC manufacturer.

Information



For further information on technology, delivery terms and conditions and prices please contact your nearest Infineon Technologies Office in Germany or our Infineon Technologies Representatives worldwide (see address list).

Warnings

Due to technical requirements components may contain dangerous substances. For information on the types in question please contact your nearest Infineon Technologies Office.
 Infineon Technologies Components may only be used in life-support devices or systems with the express written approval of Infineon Technologies, if a failure of such components can reasonably be expected to cause the failure of that life-support device or system, or to affect the safety or effectiveness of that device or system. Life support devices or systems are intended to be implanted in the human body, or to support and/or maintain and sustain and/or protect human life. If they fail, it is reasonable to assume that the health of the user or other persons may be endangered.

Looking for pricing, stock, or lifecycle information?

Click below to explore more details on WIN SOURCE:

-  [View TLE4913HTSA1 on WIN SOURCE](#)
-  [Infineon Technologies Information](#)

Optimize Your Supply Chain with WIN SOURCE Solutions

-  Global Sourcing Solution
-  Obsolete Management
-  Cost Control Management
-  Shortage Management
-  Alternative Solution
-  Excess Inventory Management