



# TLC2551, TLC2552, TLC2555

## 5-V, LOW-POWER, 12-BIT, 175/360 KSPS, SERIAL ANALOG-TO-DIGITAL CONVERTERS WITH AUTOPOWER DOWN

SLAS276D – MARCH 2000 – REVISED MAY 2003

- Maximum Throughput . . . 175/360 KSPS
- INL/DNL:  $\pm 1$  LSB Max, SINAD: 72 dB, SFDR: 85 dB,  $f_i = 20$  kHz
- SPI/DSP-Compatible Serial Interface
- Single 5-V Supply
- Rail-to-Rail Analog Input With 500 kHz BW
- Three Options Available:
  - TLC2551: Single Channel Input
  - TLC2552: Dual Channels With Autosweep
  - TLC2555: Single Channel With Pseudo-Differential Input
- Low Power With Autopower Down
  - Operating Current: 3.5 mA
  - Autopower Down: 8  $\mu$ A
- Small 8-Pin MSOP and SOIC Packages

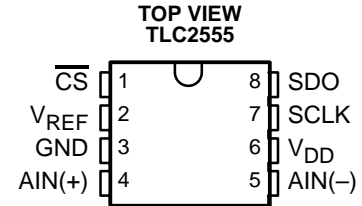
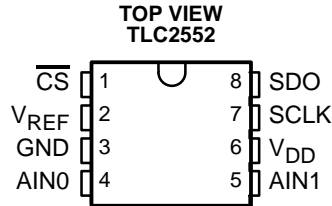
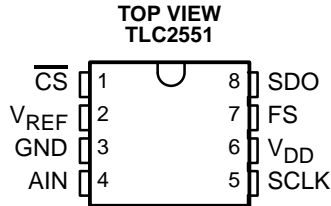

### description

The TLC2551, TLC2552, and TLC2555 are a family of high performance, 12-bit, low-power, miniature, CMOS analog-to-digital converters (ADC). The TLC255x family uses a 5-V supply. Devices are available with single, dual, or single pseudo-differential inputs. Each device has a chip select ( $\overline{CS}$ ), serial clock (SCLK), and serial data output (SDO) that provides a direct 3-wire interface to the serial port of most popular host microprocessors (SPI interface). When interfaced with a TMS320™ DSP, a frame sync signal (FS) can be used to indicate the start of a serial data frame on  $\overline{CS}$  for all devices or on FS for the TLC2551.

The TLC2551, TLC2552, and TLC2555 are designed to operate with very low power consumption. The power saving feature is further enhanced with an autopower-down mode. This product family features a high-speed serial link to modern host processors with SCLK up to 20 MHz. The maximum SCLK frequency is dependent upon the mode of operation (see Table 1). The TLC255x family uses SCLK as the conversion clock, which provides synchronous operation and a minimum conversion time of 1.5  $\mu$ s using a 20-MHz SCLK.

#### AVAILABLE OPTIONS

T <sub>A</sub>	PACKAGED DEVICES	
	8-MSOP (DGK)	8-SOIC (D)
0°C to 70°C	TLC2551CDGK (AHF)	
	TLC2552CDGK (AHH)	
	TLC2555CDGK (AHJ)	
–40°C to 85°C	TLC2551IDGK (AHG)	TLC2551ID
	TLC2552IDGK (AHI)	TLC2552ID
	TLC2555IDGK (AHK)	TLC2555ID



Please be aware that an important notice concerning availability, standard warranty, and use in critical applications of Texas Instruments semiconductor products and disclaimers thereto appears at the end of this data sheet.

TMS320 is a trademark of Texas Instruments.

PRODUCTION DATA information is current as of publication date. Products conform to specifications per the terms of Texas Instruments standard warranty. Production processing does not necessarily include testing of all parameters.



POST OFFICE BOX 655303 • DALLAS, TEXAS 75265

Copyright © 2002 – 2003, Texas Instruments Incorporated

**TLC2551, TLC2552, TLC2555**  
**5-V, LOW-POWER, 12-BIT, 175/360 KSPS,**  
**SERIAL ANALOG-TO-DIGITAL CONVERTERS WITH AUTOPOWER DOWN**

SLAS276D – MARCH 2000 – REVISED MAY 2003

**functional block diagram**

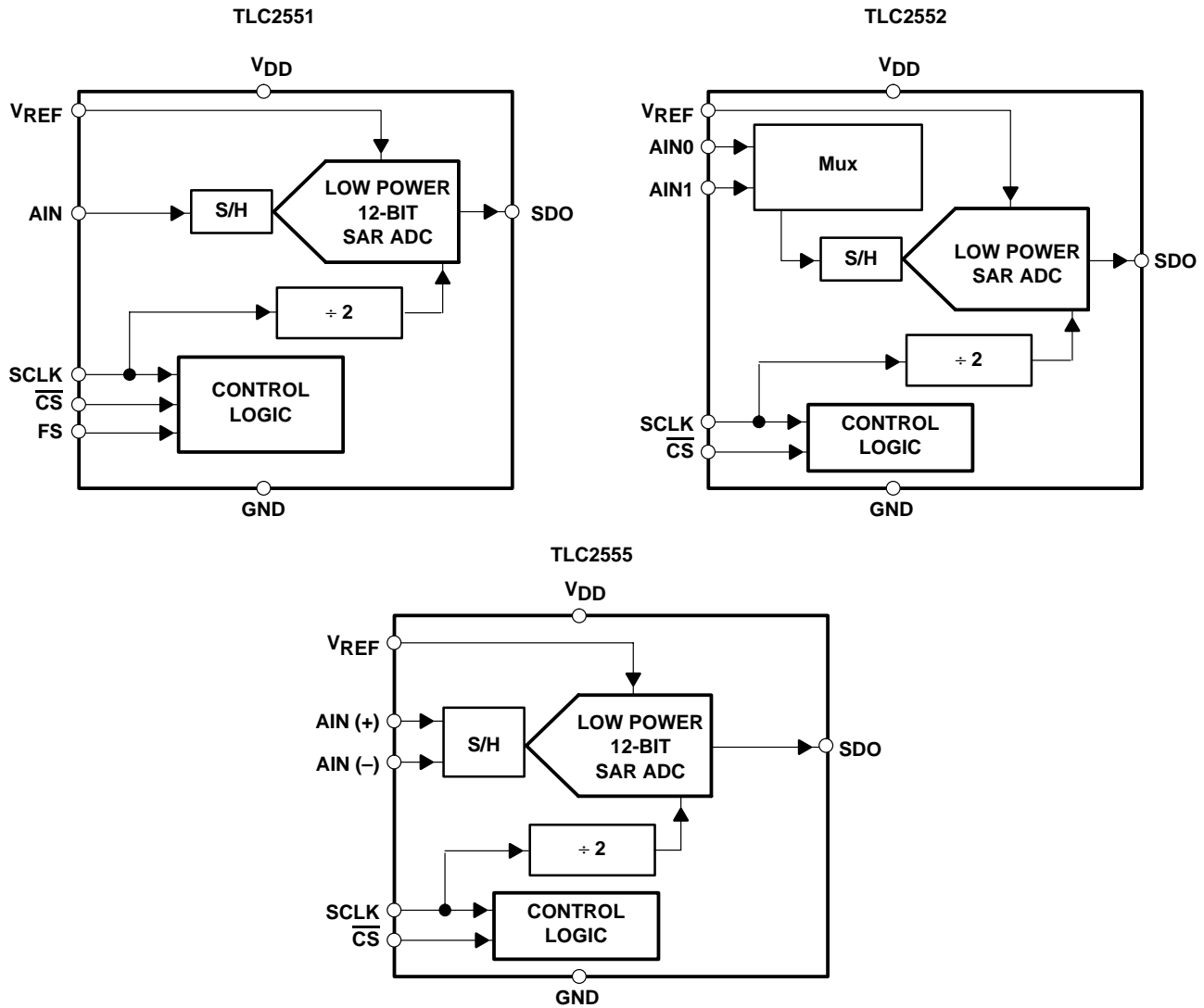

## Terminal Functions

### TLC2551

TERMINAL		I/O	DESCRIPTION
NAME	NO.		
AIN	4	I	Analog input channel
$\overline{\text{CS}}$	1	I	Chip select. A high-to-low transition on the $\overline{\text{CS}}$ input removes SDO from 3-state within a maximum setup time. $\overline{\text{CS}}$ can be used as the FS pin when a dedicated DSP serial port is used.
FS	7	I	DSP frame sync input. Indication of the start of a serial data frame. Tie this terminal to $V_{\text{DD}}$ if not used.
GND	3	I	Ground return for the internal circuitry. Unless otherwise noted, all voltage measurements are with respect to GND.
SCLK	5	I	Output serial clock. This terminal receives the serial SCLK from the host processor.
SDO	8	O	The 3-state serial output for the A/D conversion result. SDO is kept in the high-impedance state until $\overline{\text{CS}}$ falling edge or FS rising edge, whichever occurs first. The output format is MSB first.  When FS is not used ( $\text{FS} = 1$ at the falling edge of $\overline{\text{CS}}$ ), the MSB is presented to the SDO pin after $\overline{\text{CS}}$ falling edge and output data is valid on the first falling edge of SCLK.  When $\overline{\text{CS}}$ and FS are both used ( $\text{FS} = 0$ at the falling edge of $\overline{\text{CS}}$ ), the MSB is presented to the SDO pin after the falling edge of $\overline{\text{CS}}$ . When $\overline{\text{CS}}$ is tied/held low, the MSB is presented on SDO after rising FS. Output data is valid on the first falling edge of SCLK. (This is typically used with an active FS from a DSP.)
$V_{\text{DD}}$	6	I	Positive supply voltage
$V_{\text{REF}}$	2	I	External reference input

### TLC2552/55

TERMINAL		I/O	DESCRIPTION
NAME	NO.		
AIN0 /AIN(+)	4	I	Analog input channel 0 for TLC2552—Positive input for TLC2555
AIN1/AIN(–)	5	I	Analog input channel 1 for TLC2552—Inverted input for TLC2555
$\overline{\text{CS}}$	1	I	Chip select. A high-to-low transition on $\overline{\text{CS}}$ removes SDO from 3-state within a maximum delay time. This pin can be connected to the FS output from a DSP on a dedicated serial port.
GND	3	I	Ground return for the internal circuitry. Unless otherwise noted, all voltage measurements are with respect to GND.
SCLK	7	I	Output serial clock. This terminal receives the serial SCLK from the host processor.
SDO	8	O	The 3-state serial output for the A/D conversion result. SDO is kept in the high-impedance state when $\overline{\text{CS}}$ is high and presents output data after the $\overline{\text{CS}}$ falling edge until the LSB is presented. The output format is MSB first. SDO returns to the Hi-Z state after the 16th SCLK. Output data is valid on the falling SCLK edge.
$V_{\text{DD}}$	6	I	Positive supply voltage
$V_{\text{REF}}$	2	I	External reference input

### detailed description

The TLC2551, TLC2552, and TLC2555 are successive approximation (SAR) ADCs utilizing a charge redistribution DAC. Figure 1 shows a simplified version of the ADC.

The sampling capacitor acquires the signal on AIN during the sampling period. When the conversion process starts, the SAR control logic and charge redistribution DAC are used to add and subtract fixed amounts of charge from the sampling capacitor to bring the comparator into a balanced condition. When the comparator is balanced, the conversion is complete and the ADC output code is generated.

**detailed description (continued)**

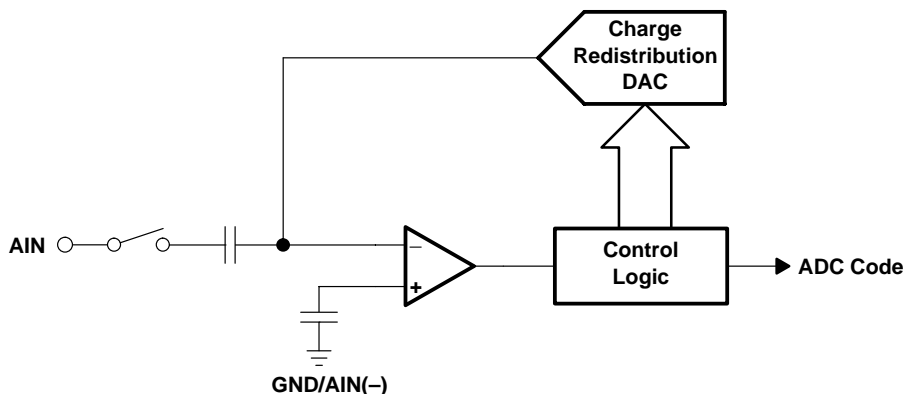

**Figure 1. Simplified SAR Circuit**

**serial interface**

OUTPUT DATA FORMAT	
MSB	LSB
D15–D4	D3–D0
Conversion result (OD11–OD0)	Don't care

The output data format is binary (unipolar straight binary).

**binary**

Zero-scale code = 000h,  $V_{code} = GND$   
 Full-scale code = FFFh,  $V_{code} = V_{REF} - 1 \text{ LSB}$

**pseudo-differential inputs**

The TLC2555 operates in pseudo-differential mode. The inverted input is available on pin 5. It can have a maximum input ripple of  $\pm 0.2 \text{ V}$ . This is normally used for ground noise rejection.

**control and timing**

**start of the cycle**

Each cycle may be started by either  $\overline{CS}$ , FS, or a combination of both. The internal state machine requires one SCLK high-to-low transition to determine the state of these control signals so internal blocks can be powered up in an active cycle. Special care to SPI mode is necessary. Make sure there is at least one SCLK whenever  $\overline{CS}$  (pin 1) is high to assure proper operation.

**TLC2551**

- Control via  $\overline{CS}$  (FS = 1 at the falling edge of  $\overline{CS}$ )—The falling edge of  $\overline{CS}$  is the start of the cycle. The MSB may be read on the first falling SCLK edge after  $\overline{CS}$  is low. Output data changes on the rising edge of SCLK. This is typically used for a microcontroller with an SPI interface, although it can also be used for a DSP. The microcontroller SPI interface may be programmed for CPOL = 0 (serial clock referenced to ground) and CPHA = 1 (data is valid on the falling edge of serial clock). At least one falling edge transition on SCLK is needed whenever  $\overline{CS}$  is brought high.
- Control via FS—The MSB is presented after the rising edge of FS. The falling edge of FS starts the cycle. The MSB may be read on the first falling edge of SCLK after FS is low. This is the typical configuration when the ADC is the only device on the DSP serial port.

### control and timing (continued)

- Control via both  $\overline{CS}$  and FS—The MSB is presented after the falling edge of  $\overline{CS}$ . The falling edge of FS starts the sampling cycle. The MSB may be read on the first falling SCLK edge after FS is low. Output data changes on the rising edge of SCLK. This control via  $\overline{CS}$  and FS is typically used for multiple devices connected to a TMS320 DSP.

#### TLC2552 and TLC2555

All control is provided using  $\overline{CS}$  (pin 1) on the TLC2552 and TLC2555. The cycle starts on the falling edge transition provided by either a  $\overline{CS}$  signal from an SPI microcontroller or FS signal from a TMS320 DSP. Timing is similar to the TLC2551, with control via  $\overline{CS}$  only.

### TLC2552 channel MUX reset cycle

The TLC2552 uses  $\overline{CS}$  to reset the analog input multiplexer (MUX). A short active  $\overline{CS}$  cycle (4 to 7 SCLKs) resets the MUX to AIN0. When the  $\overline{CS}$  cycle time is greater than 7 SCLKs in duration, as is the case for a complete conversion cycle, ( $\overline{CS}$  is low for 16 SCLKs plus maximum conversion time), the MUX toggles to the next channel (see Figure 4 for timing).

### sampling

The converter sample time is 12 SCLKs in duration, beginning on the fifth SCLK received after the converter has received a high-to-low  $\overline{CS}$  transition (or a high-to-low FS transition for the TLC2551).

### conversion

The TLC2551, TLC2552, and TLC2555 completes conversion in the following manner. The conversion starts after the 16th SCLK falling edge during the cycle and requires 28 SCLKs to complete. Enough time for conversion should be allowed before a rising  $\overline{CS}$  or FS edge so that no conversion is terminated prematurely.

TLC2552 input channel selection is toggled on each rising  $\overline{CS}$  edge. The MUX channel can be reset to AIN0 via  $\overline{CS}$  as described earlier and in Figure 4. The input is sampled for 12 SCLKs and converted. The result is presented on SDO during the next cycle. Care should also be taken to allow enough time between samples to avoid prematurely terminating the cycle, which occurs on a rising  $\overline{CS}$  transition if the conversion is not complete.

The SDO data presented during a cycle is the result of the conversion of the sample taken during the previous cycle.

**TLC2551, TLC2552, TLC2555**  
**5-V, LOW-POWER, 12-BIT, 175/360 KSPS,**  
**SERIAL ANALOG-TO-DIGITAL CONVERTERS WITH AUTOPOWER DOWN**  
 SLAS276D – MARCH 2000 – REVISED MAY 2003

**timing diagrams/conversion cycles**

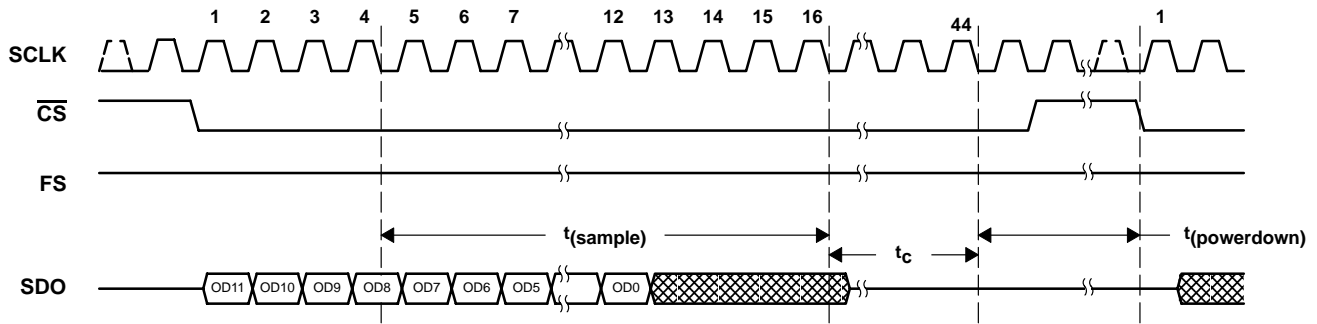

**Figure 2. TLC2551 Timing: Control via  $\overline{CS}$  (FS = 1)**

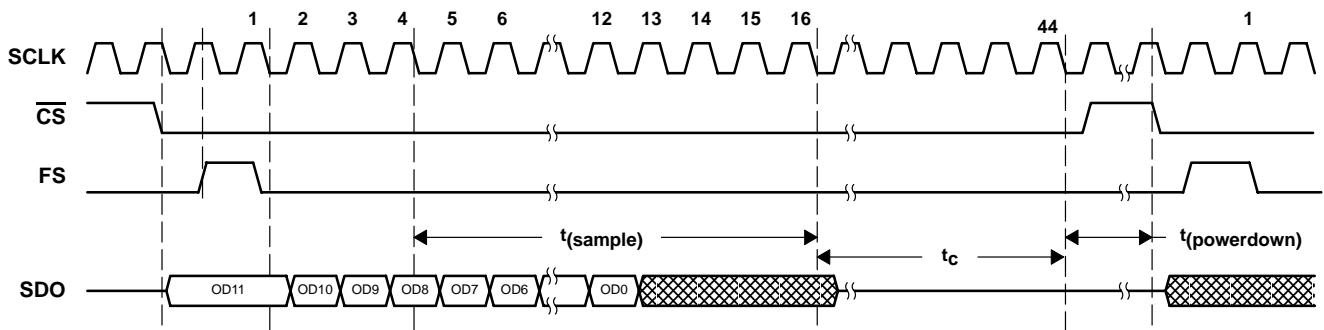

**Figure 3. TLC2551 Timing: Control via  $\overline{CS}$  and FS or FS Only**

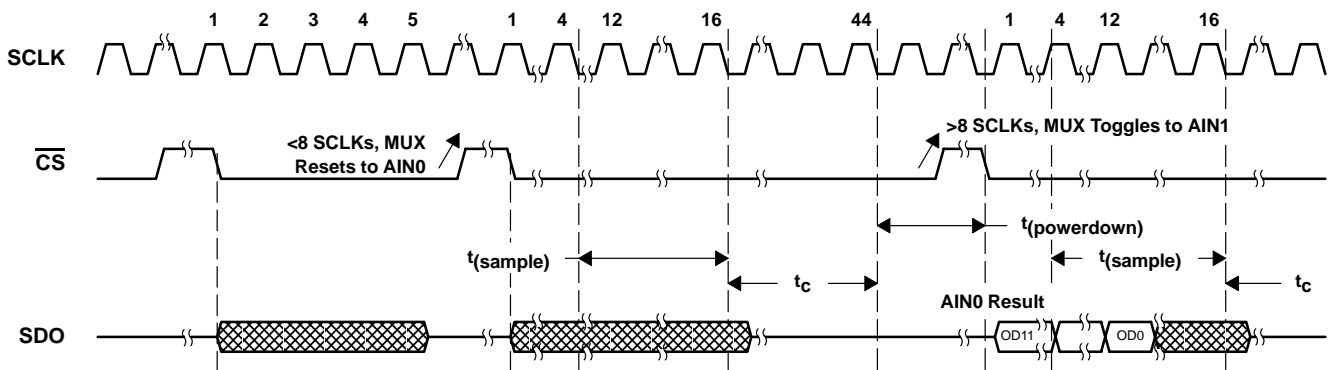

**Figure 4. TLC2552 Reset Timing**

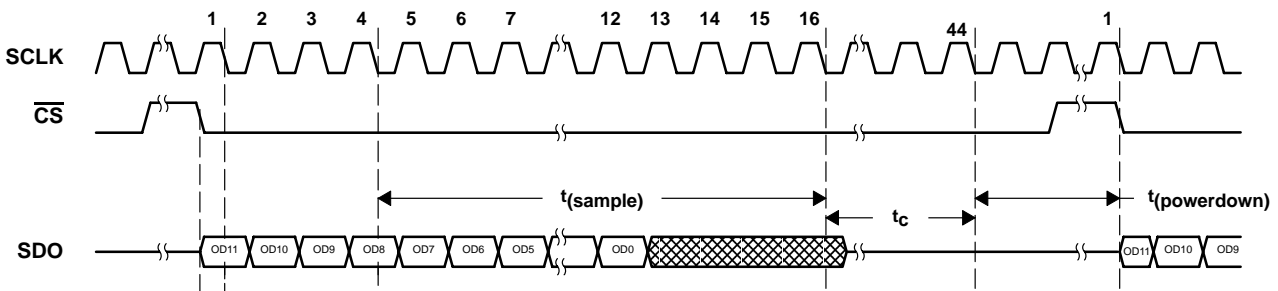

**Figure 5. TLC2552 and TLC2555 Timing**



### using $\overline{CS}$ as the FS input

When interfacing the TLC2551 with the TMS320 DSP, the FSR signal from the DSP may be connected to the  $\overline{CS}$  input if this is the only device on the serial port. This connection saves one output terminal from the DSP. (Output data changes on the falling edge of SCLK. This is the default configuration for the TLC2552 and TLC2555).

### SCLK and conversion speed

The SCLK input can range in frequency from 100 kHz to 20 MHz. The required number of conversion clocks is 14. The conversion clock for the ADC is SCLK/2 which translates to 28 SCLK cycles to perform a conversion. For a 15-MHz SCLK, the minimum total cycle time is given by:  $16x(1/15\text{ M})+14x(1/7.5\text{ M})+1\text{ SCLK} = 3.0\ \mu\text{s}$ . An additional SCLK is added to account for the required  $\overline{CS}$  or FS high time. These times specify the minimum cycle time for an active  $\overline{CS}$  or FS signal. If violated, the conversion terminates, invalidating the next data output cycle. Table 1 gives the maximum SCLK frequency for a given operational mode.

### control via pin 1 ( $\overline{CS}$ , SPI interface)

All devices are compatible with this mode of operation. A falling  $\overline{CS}$  initiates the cycle. (For TLC2551, the FS input is tied to  $V_{DD}$ .)  $\overline{CS}$  remains low for the entire cycle time (sample + convert + 1 SCLK) and can then be released.

**NOTE:**

IMPORTANT: A single SCLK is required whenever  $\overline{CS}$  is high.

### control via pin 1 ( $\overline{CS}$ , DSP interface)

All devices are compatible with this mode of operation. The FS signal from a DSP is connected directly to the  $\overline{CS}$  input of the ADC. A falling edge on the  $\overline{CS}$  input initiates the cycle. (For TLC2551, the FS input can be tied to  $V_{DD}$ , although better performance can be achieved by using the FS input for control. Refer to the *control via pin 1 and pin 7 ( $\overline{CS}$  and FS or FS only, DSP interface)* section. The  $\overline{CS}$  input should remain low for the entire cycle time (sample + convert + 1 SCLK) and can then be released.

**NOTE:**

IMPORTANT: A single SCLK is required whenever  $\overline{CS}$  is high. This requirement is usually of little consequence since SCLK is normally always present when interfacing with a DSP.

### control via pin 1 and pin 7 ( $\overline{CS}$ and FS or FS only, DSP interface)

Only the TLC2551 is compatible with this mode of operation. The  $\overline{CS}$  input to the ADC can be controlled via a general-purpose I/O pin from the DSP. The FS signal from the DSP is connected directly to the FS input of the ADC. A falling edge on  $\overline{CS}$ , if used, releases the MSB on the SDO output. When  $\overline{CS}$  is not used, the rising FS edge releases the MSB. The falling edge on the FS input while SCLK is high initiates the cycle. The  $\overline{CS}$  and FS inputs should remain low for the entire cycle time (sample + convert + 1 SCLK) and can then be released.

### reference voltage

An external reference is applied via  $V_{REF}$ . The voltage level applied to this pin establishes the upper limit of the analog inputs to produce a full-scale reading. The value of  $V_{REF}$  and the analog input must not exceed the positive supply or be less than GND, consistent with the specified absolute maximum ratings. The digital output is at full scale when the input signal is equal to or higher than  $V_{REF}$  and at zero when the input signal is equal to or lower than GND.

### powerdown and powerup

Autopower down is built into these devices in order to reduce power consumption. The actual power savings depends on the inactive time between cycles and the power supply (loading) decoupling/storage capacitors. *Power-down takes effect immediately after the conversion is complete.* This is fast enough to provide some power savings between cycles with longer than 1 SCLK inactive time. *The device power goes down to 8  $\mu\text{A}$  within 0.5  $\mu\text{s}$ .* To achieve the lowest power-down current (*deep powerdown*) of 1  $\mu\text{A}$  requires 2-ms inactive time between cycles. The power-down state is initiated at the end of conversion. These devices wake up *immediately* at the next falling edge of  $\overline{CS}$  or the rising edge of FS.

**TLC2551, TLC2552, TLC2555**  
**5-V, LOW-POWER, 12-BIT, 175/360 KSPS,**  
**SERIAL ANALOG-TO-DIGITAL CONVERTERS WITH AUTOPOWER DOWN**

SLAS276D – MARCH 2000 – REVISED MAY 2003

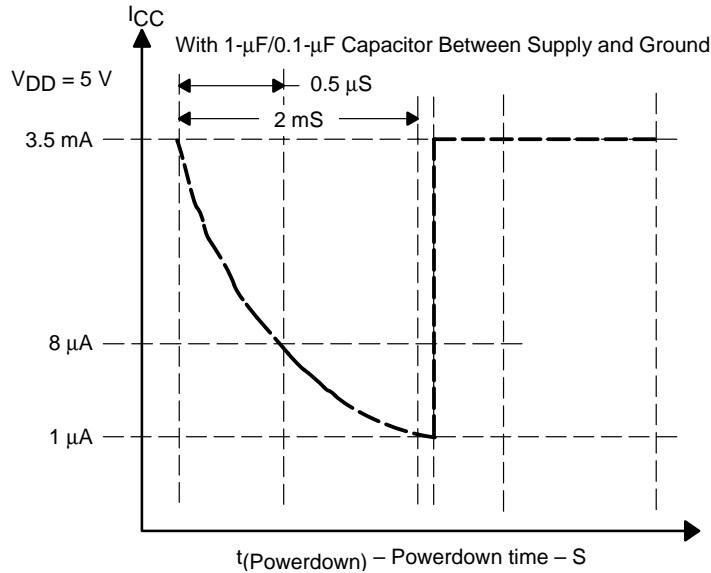

**Table 1. Modes of Operation and Data Throughput**

CONTROL PIN(s)/DEVICE	MAX SCLK (MHz) (50/50 duty cycle) V <sub>DD</sub> = 4.5 V	APPROXIMATE CONVERSION THROUGHPUT (ksp/s) V <sub>DD</sub> = 4.5 V
$\overline{\text{CS}}$ control only (TLC2551 only)		
For SPI†	15	333
DSP interface‡	8	175
$\overline{\text{CS}}$ and FS control (TLC2551 only)§		
DSP interface	20	400

† See Figure 21(a).  
 ‡ See Figure 21(b).  
 § See Figure 21(c).

**absolute maximum ratings over operating free-air temperature (unless otherwise noted)¶**

Supply voltage range, GND to V <sub>DD</sub>	-0.3 V to 6.5 V
Analog input voltage range	-0.3 V to V <sub>DD</sub> + 0.3 V
Reference input voltage	V <sub>DD</sub> + 0.3 V
Digital input voltage range	-0.3 V to V <sub>DD</sub> + 0.3 V
Operating virtual junction temperature range, T <sub>J</sub>	-40°C to 150°C
Operating free-air temperature range, T <sub>A</sub> : C	0°C to 70°C
I	-40°C to 85°C
Storage temperature range, T <sub>stg</sub>	-65°C to 150°C
Lead temperature 1,6 mm (1/16 inch) from case for 10 seconds	260°C

¶ Stresses beyond those listed under “absolute maximum ratings” may cause permanent damage to the device. These are stress ratings only, and functional operation of the device at these or any other conditions beyond those indicated under “recommended operating conditions” is not implied. Exposure to absolute-maximum-rated conditions for extended periods may affect device reliability.



**TLC2551, TLC2552, TLC2555**  
**5-V, LOW-POWER, 12-BIT, 175/360 KSPS,**  
**SERIAL ANALOG-TO-DIGITAL CONVERTERS WITH AUTOPOWER DOWN**

SLAS276D – MARCH 2000 – REVISED MAY 2003

**recommended operating conditions**

		MIN	NOM	MAX	UNIT
Supply voltage, $V_{DD}$		4.5	5	5.5	V
Positive external reference voltage input, $V_{REFP}$ (see Note 1)		2		$V_{DD}$	V
Analog input voltage (see Note 1)		0		$V_{DD}$	V
High level control input voltage, $V_{IH}$		2.1			V
Low-level control input voltage, $V_{IL}$				0.6	V
Setup time, $\overline{CS}$ falling edge before first SCLK falling edge, $t_{su}(CSL-SCLKL)$	$V_{DD} = REF = 4.5\text{ V}$	40			ns
Hold time, $\overline{CS}$ falling edge after SCLK falling edge, $t_h(SCLKL-CSL)$		5			ns
Delay time, delay from $\overline{CS}$ falling edge to FS rising edge $t_d(CSL-FSH)$ (TLC2551 only)		0.5		7	SCLKs
Setup time, FS rising edge before SCLK falling edge, $t_{su}(FSH-SCLKL)$ (TLC2551 only)		0.35			SCLKs
Hold time, FS hold high after SCLK falling edge, $t_h(SCLKL-FSL)$ (TLC2551 only)				0.65	SCLKs
Pulse width $\overline{CS}$ high time, $t_w(H\_CS)$		100			ns
Pulse width FS high time, $t_w(H\_FS)$ (TLC2551 only)		0.75			SCLKs
SCLK cycle time, $V_{DD} = 5.5\text{ V}$ to $4.5\text{ V}$ , $t_c(SCLK)$ (maximum tolerance of 40/60 duty cycle)		50		10000	ns
Pulse width low time, $t_w(L\_SCLK)$		0.4		0.6	SCLKs
Pulse width high time, $t_w(H\_SCLK)$		0.4		0.6	SCLKs
Hold time, hold from end of conversion to $\overline{CS}$ high, $t_h(EOC-CSH)$ (EOC is internal, indicates end of conversion time, $t_c$ )			0.05		$\mu\text{s}$
Active $\overline{CS}$ cycle time to reset internal MUX to AIN0, $t_{(Reset\ cycle)}$ (TLC2552 only)		4		7	SCLKs
Delay time, delay from $\overline{CS}$ falling edge to SDO valid, $t_d(CSL-SDOV)$	$V_{DD} = REF = 4.5\text{ V}$ , 25-pF load			40	ns
Delay time, delay from FS falling edge to SDO valid, $t_d(FSL-SDOV)$ (TLC2551 only)	$V_{DD} = REF = 4.5\text{ V}$ , 25-pF load			1	ns
Delay time, delay from SCLK rising edge to SDO valid, $t_d(SCLKH-SDOV)$	$V_{DD} = REF = 4.5\text{ V}$ , 25-pF load			11	ns
Delay time, delay from 17th SCLK rising edge to SDO 3-state, $t_d(SCLK17H-SDOZ)$	$V_{DD} = REF = 4.5\text{ V}$ , 25-pF load			30	ns
Conversion time, $t_c$			28		SCLKs
Sampling time, $t_{(sample)}$	See Note 2	300			ns
Operating free-air temperature, $T_A$	TLC2551/2/5C	0		70	°C
	TLC2551/2/5I	-40		85	

- NOTES: 1. Analog input voltages greater than that applied to  $V_{REF}$  convert as all ones (111111111111), while input voltages less than that applied to GND convert as all zeros(000000000000).
2. Minimal  $t_{(sample)}$  is given by  $0.9 \times 50\text{ pF} \times (R_S + 0.5\text{ k}\Omega)$ , where  $R_S$  is the source output impedance.



**TLC2551, TLC2552, TLC2555**  
**5-V, LOW-POWER, 12-BIT, 175/360 KSPS,**  
**SERIAL ANALOG-TO-DIGITAL CONVERTERS WITH AUTOPOWER DOWN**

SLAS276D – MARCH 2000 – REVISED MAY 2003

**electrical characteristics over recommended operating free-air temperature range,**  
 **$V_{DD} = V_{REF} = 4.5\text{ V to }5.5\text{ V}$ , (unless otherwise noted)**

PARAMETER		TEST CONDITIONS	MIN	TYP†	MAX	UNIT
$V_{OH}$	High-level output voltage	$V_{DD} = 5.5\text{ V}$ , $I_{OH} = -0.2\text{ mA}$ at 30-pF load	2.4			V
$V_{OL}$	Low-level output voltage	$V_{DD} = 5.5\text{ V}$ , $I_{OL} = 0.8\text{ mA}$ at 30-pF load			0.4	V
$I_{OZ}$	Off-state output current (high-impedance-state)	$V_O = V_{DD}$		1	2.5	$\mu\text{A}$
		$V_O = 0$		-1	-2.5	
$I_{IH}$	High-level input current	$V_I = V_{DD}$		0.005	2.5	$\mu\text{A}$
$I_{IL}$	Low-level input current	$V_I = 0\text{ V}$		-0.005	2.5	$\mu\text{A}$
$I_{CC}$	Operating supply current	$\overline{CS}$ at 0 V, $V_{DD} = 4.5\text{ V to }5.5\text{ V}$		3	3.5	mA
$I_{CC}(\text{AUTOPWDN})$	Autopower-down current $t(\text{powerdown}) \geq 0.5\ \mu\text{s}$	For all digital inputs, $0 \leq V_I \leq 0.3\text{ V}$ or $V_I \geq V_{DD} - 0.3\text{ V}$ , $SCLK = 0$ , $V_{DD} = 4.5\text{ V to }5.5\text{ V}$ , Ext ref			8	$\mu\text{A}$
	Deep autopower-down current $t(\text{powerdown}) \geq 2\text{ ms}$				1	
	Selected analog input channel leakage current	Selected channel at $V_{DD}$			1	$\mu\text{A}$
		Selected channel at 0 V			-1	
$C_i$	Input capacitance	Analog inputs	20	45	50	pF
		Control Inputs		5	25	
	Input on resistance	$V_{DD} = 5.5\text{ V}$			500	$\Omega$

† All typical values are at  $V_{DD} = 5\text{ V}$ ,  $T_A = 25^\circ\text{C}$ .



**TLC2551, TLC2552, TLC2555**  
**5-V, LOW-POWER, 12-BIT, 175/360 KSPS,**  
**SERIAL ANALOG-TO-DIGITAL CONVERTERS WITH AUTOPOWER DOWN**

SLAS276D – MARCH 2000 – REVISED MAY 2003

**ac specifications ( $f_i = 20$  kHz)**

PARAMETER		TEST CONDITIONS	MIN	TYP	MAX	UNIT
SINAD	Signal-to-noise ratio + distortion	400 KSPS, $V_{DD} = V_{REF} = 5$ V	70	72		dB
THD	Total harmonic distortion	400 KSPS, $V_{DD} = V_{REF} = 5$ V		-84	-80	dB
ENOB	Effective number of bits	400 KSPS, $V_{DD} = V_{REF} = 5$ V		11.8		bits
SFDR	Spurious free dynamic range	400 KSPS, $V_{DD} = V_{REF} = 5$ V		-84	-80	dB
<b>Analog Input</b>						
	Full-power bandwidth, -3 dB			1		MHz
	Full-power bandwidth, -1 dB			500		kHz

**external reference specifications**

PARAMETER	TEST CONDITIONS	MIN	TYP	MAX	UNIT
Reference input voltage	$V_{DD} = 4.5$ V to $5.5$ V	2		$V_{DD}$	V
Reference input impedance	$V_{DD} = 5.5$ V	$\overline{CS} = 1$ , SCLK = 0	100		M $\Omega$
		$\overline{CS} = 0$ , SCLK = 20 MHz	20	25	k $\Omega$
Reference current	$V_{DD} = V_{REF} = 5.5$ V		100	400	$\mu$ A
Reference input capacitance	$V_{DD} = V_{REF} = 5.5$ V	$\overline{CS} = 1$ , SCLK = 0	5	15	pF
		$\overline{CS} = 0$ , SCLK = 20 MHz	20	45	
$V_{REF}$	Reference voltage	$V_{DD} = 4.5$ V to $5.5$ V		$V_{DD}$	V

**dc specification,  $V_{DD} = V_{REF} = 4.5$  V to  $5.5$  V, SCLK frequency = 20 MHz (unless otherwise noted)**

PARAMETER	TEST CONDITIONS	MIN	TYP	MAX	UNIT
INL	Integral linearity error (see Note 4)		$\pm 0.6$	$\pm 1$	LSB
DNL	Differential linearity error	See Note 3	$\pm 0.5$	$\pm 1$	LSB
$E_O$	Offset error (see Note 5)	See Note 3	TLC2551/52	$\pm 1.5$	LSB
			TLC2555	$\pm 2.5$	
$E_G$	Gain error (see Note 5)	See Note 3	TLC2551/52	$\pm 2$	LSB
			TLC2555	$\pm 5$	
$E_t$	Total unadjusted error (see Note 6)	See Note 3	TLC2551/52	$\pm 2$	LSB
			TLC2555	$\pm 5$	

- NOTES: 3. Analog input voltages greater than that applied to  $V_{REF}$  convert as all ones (111111111111).  
4. Linear error is the maximum deviation from the best straight line through the A/D transfer characteristics.  
5. Zero error is the difference between 000000000000 and the converted output for zero input voltage; full-scale error is the difference between 111111111111 and the converted output for full-scale input voltage.  
6. Total unadjusted error comprises linearity, zero, and full-scale errors.



PARAMETER MEASUREMENT INFORMATION

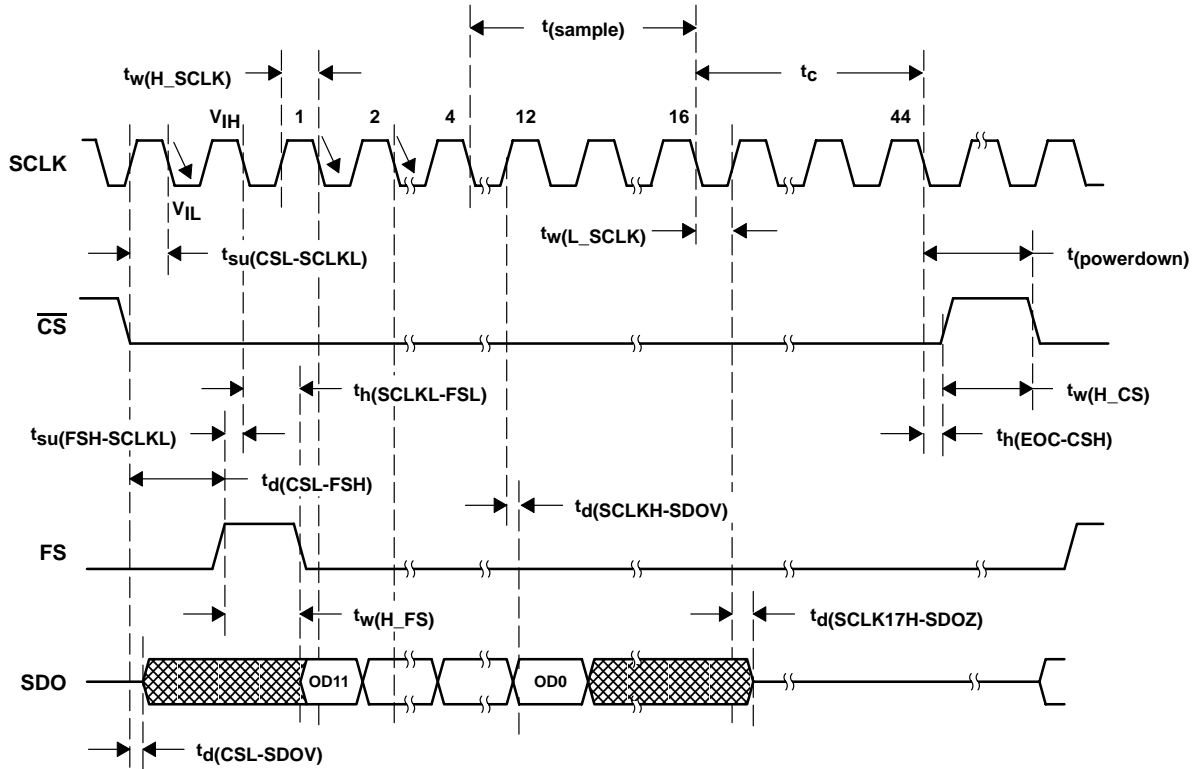

Figure 6. TLC2551 Critical Timing (Control via  $\overline{CS}$  and FS or FS only)

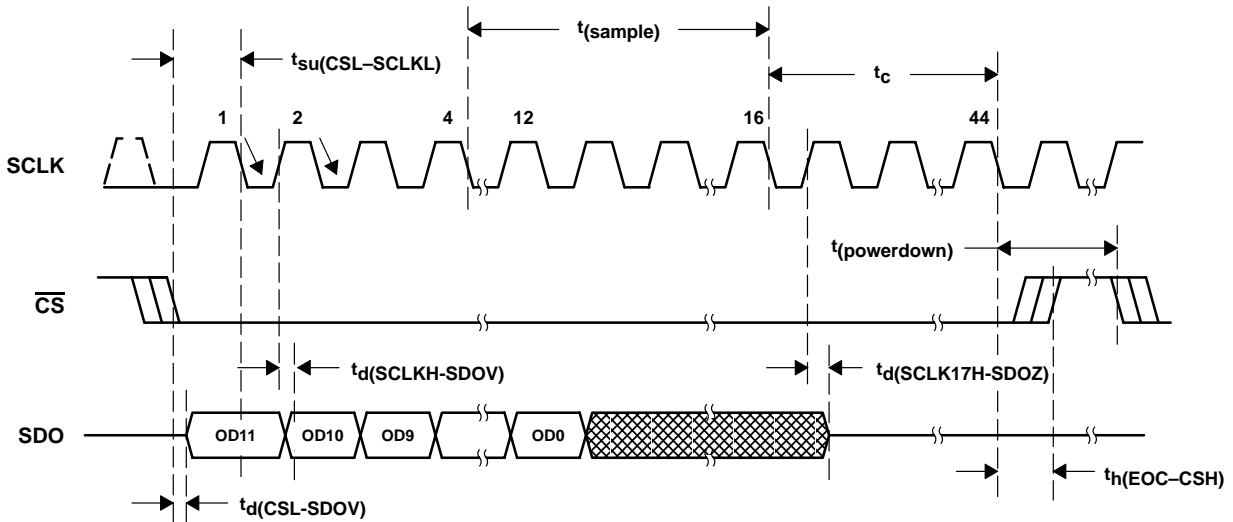
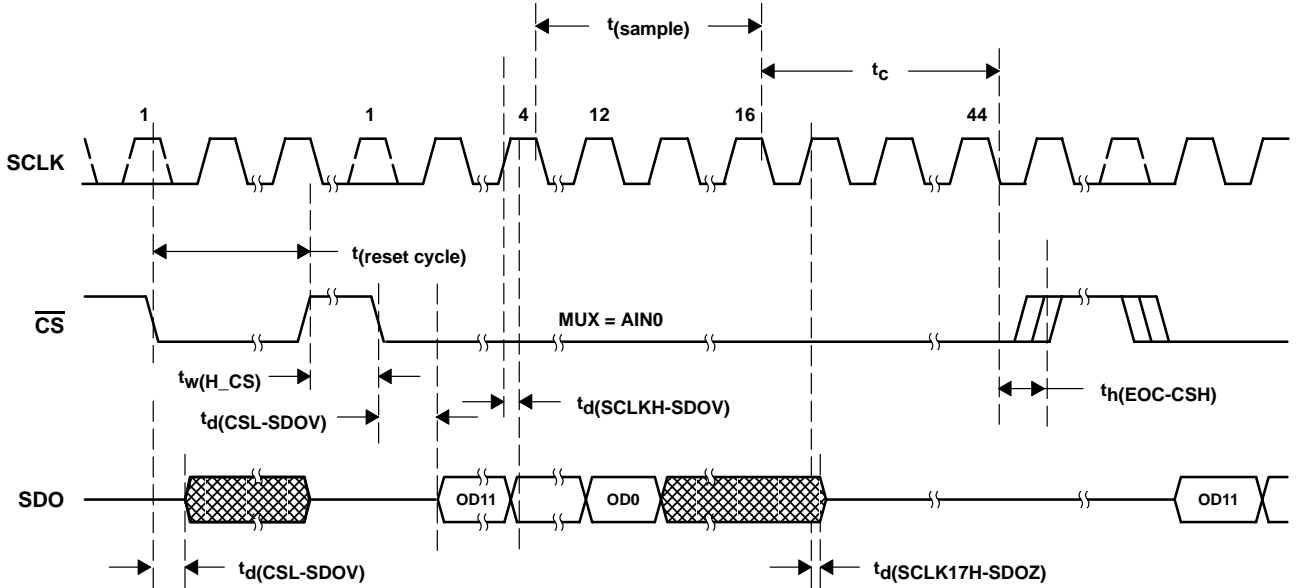
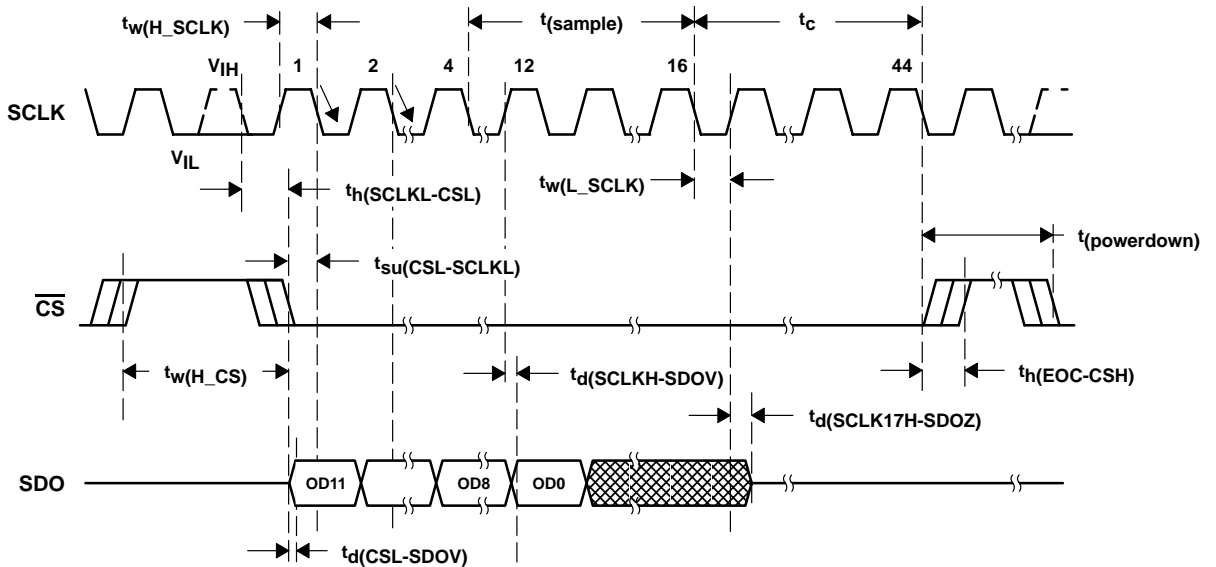

Figure 7. TLC2551 Critical Timing (Control via  $\overline{CS}$  only, FS = 1)

**PARAMETER MEASUREMENT INFORMATION**



**Figure 8. TLC2552 Reset Cycle Critical Timing**



**Figure 9. TLC2552 and TLC2555 Conversion Cycle Critical Timing**

TYPICAL CHARACTERISTICS

INTEGRAL NONLINEARITY  
 vs  
 FREE-AIR TEMPERATURE

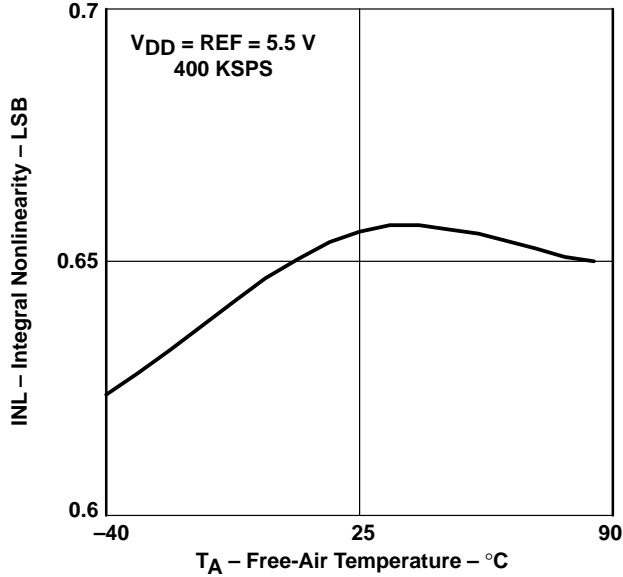

Figure 10

DIFFERENTIAL NONLINEARITY  
 vs  
 FREE-AIR TEMPERATURE

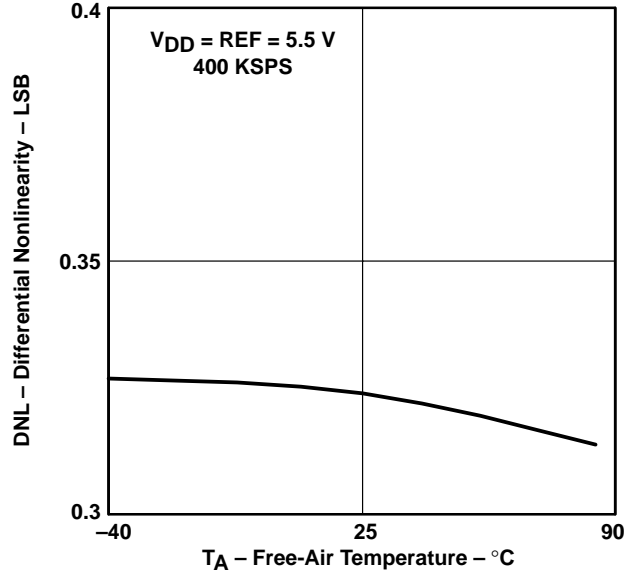

Figure 11

OFFSET ERROR  
 vs  
 FREE-AIR TEMPERATURE

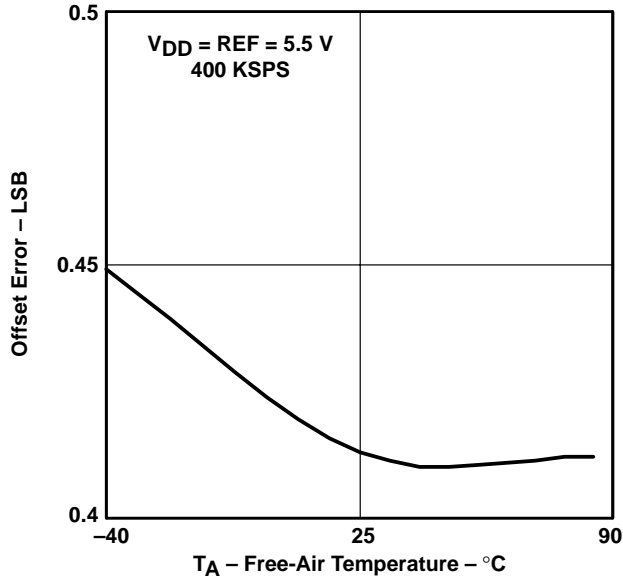

Figure 12

GAIN ERROR  
 vs  
 FREE-AIR TEMPERATURE

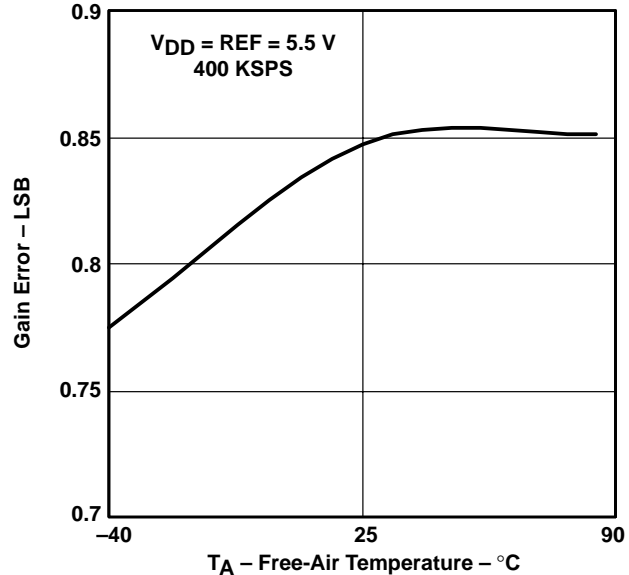

Figure 13

TYPICAL CHARACTERISTICS

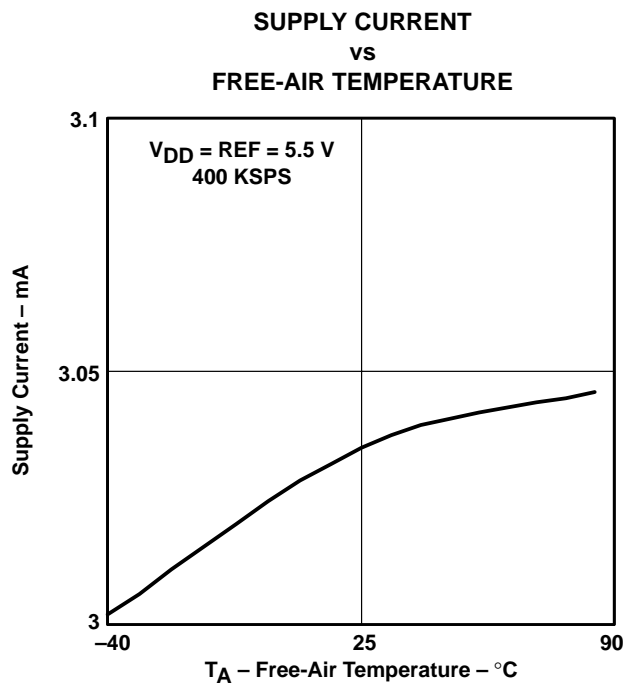

Figure 14

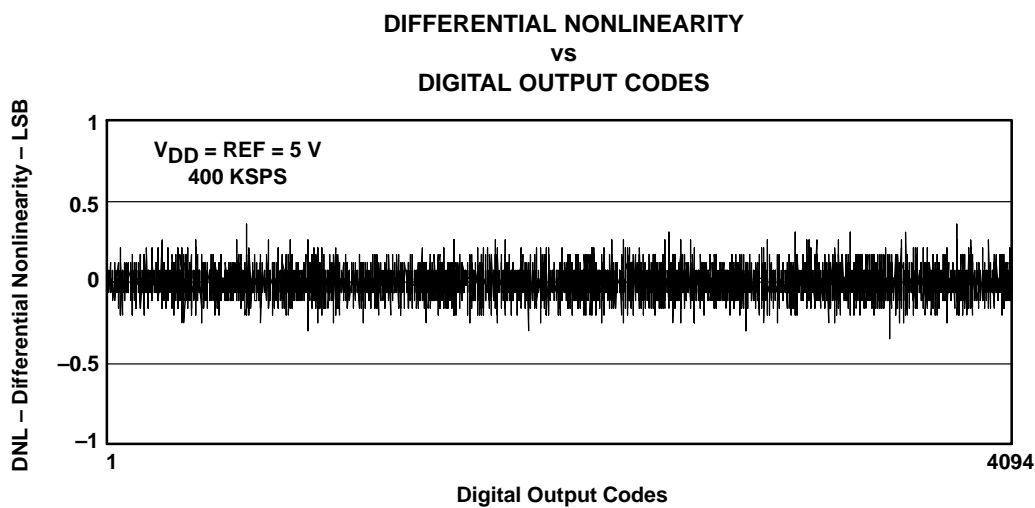

Figure 15

TYPICAL CHARACTERISTICS

INTEGRAL NONLINEARITY  
vs  
DIGITAL OUTPUT CODES

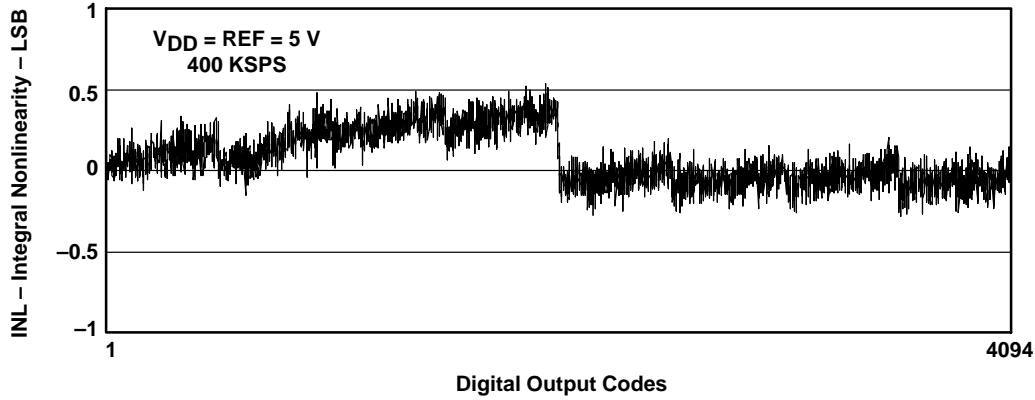

Figure 16

2048 POINTS FAST FOURIER TRANSFORM (FFT)

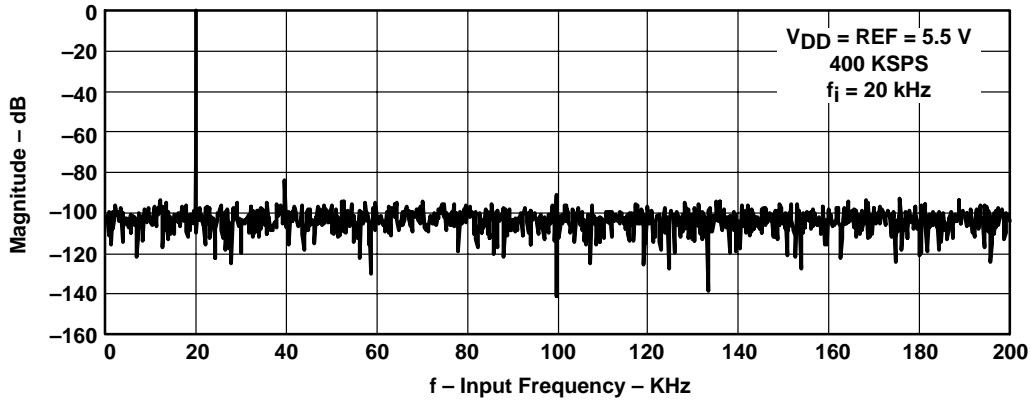
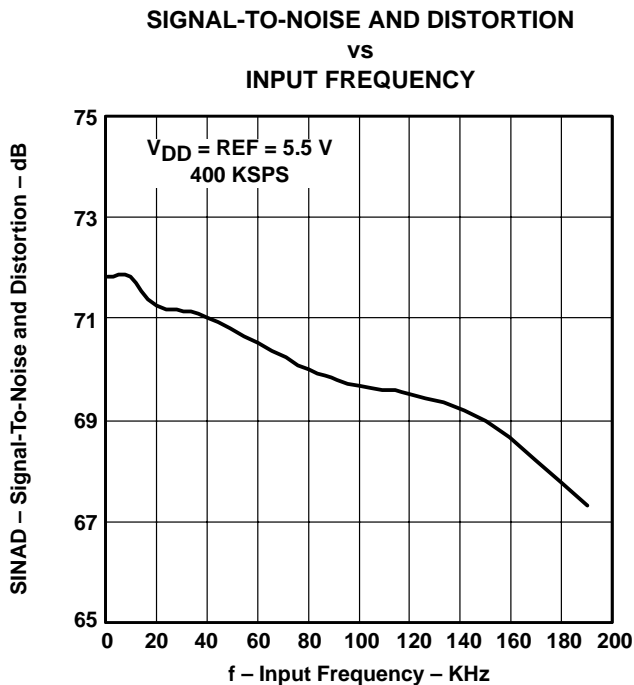
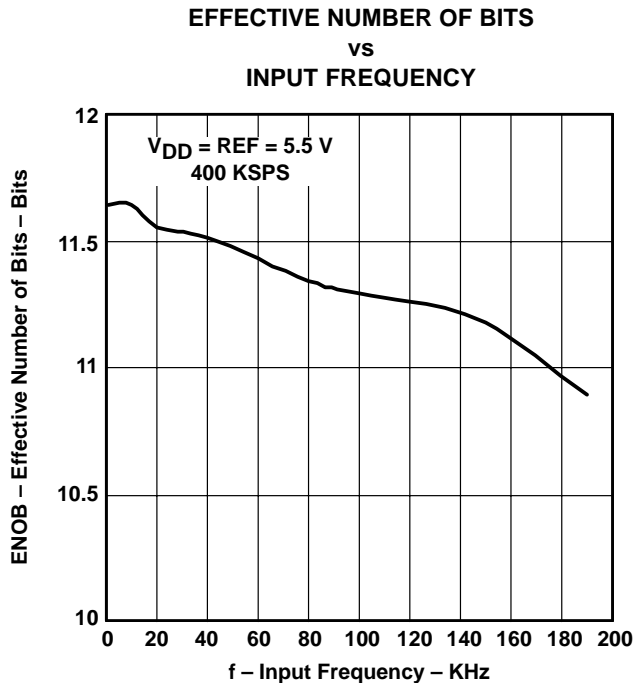

Figure 17

**TYPICAL CHARACTERISTICS**



**Figure 18**



**Figure 19**

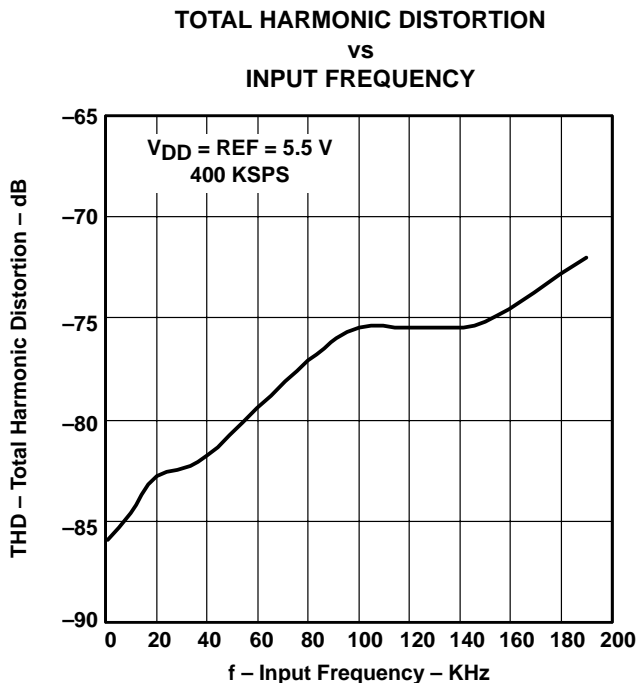

**Figure 20**

APPLICATION INFORMATION

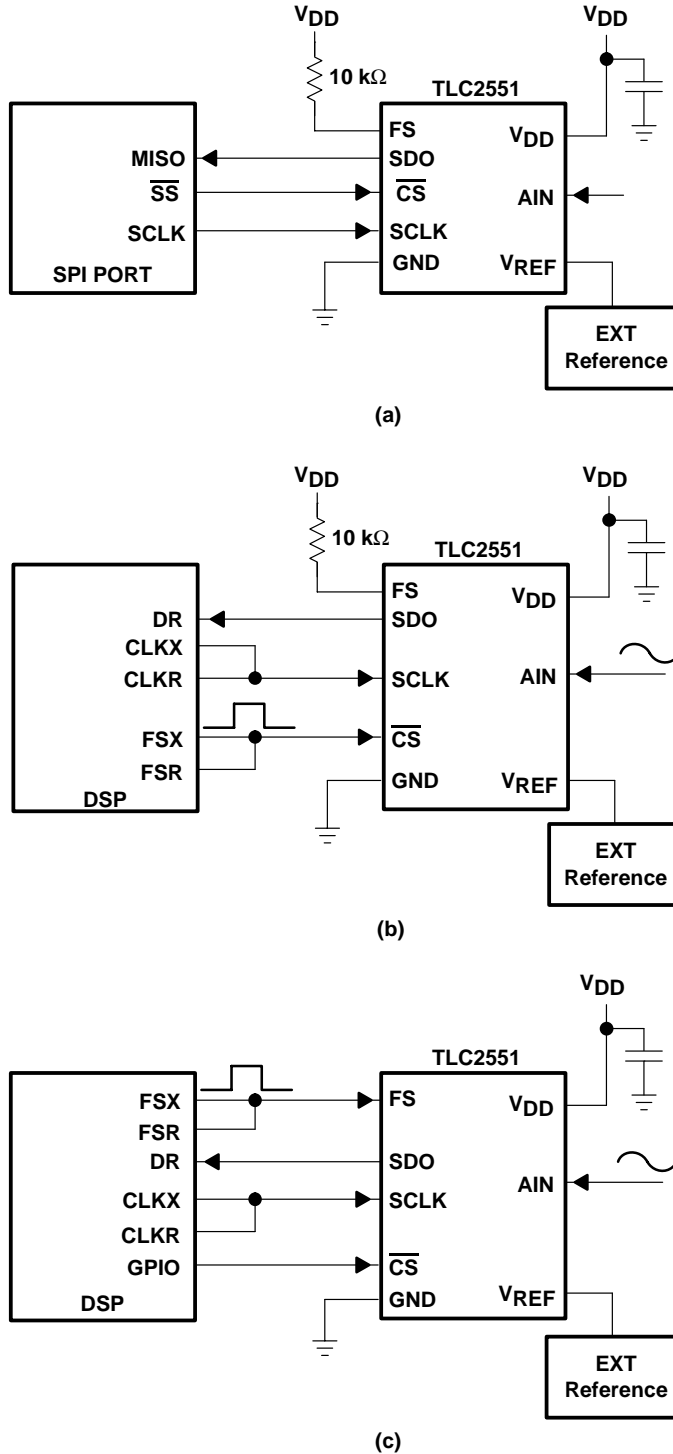

Figure 21. Typical TLC2551 Interface to a TMS320 DSP

APPLICATION INFORMATION

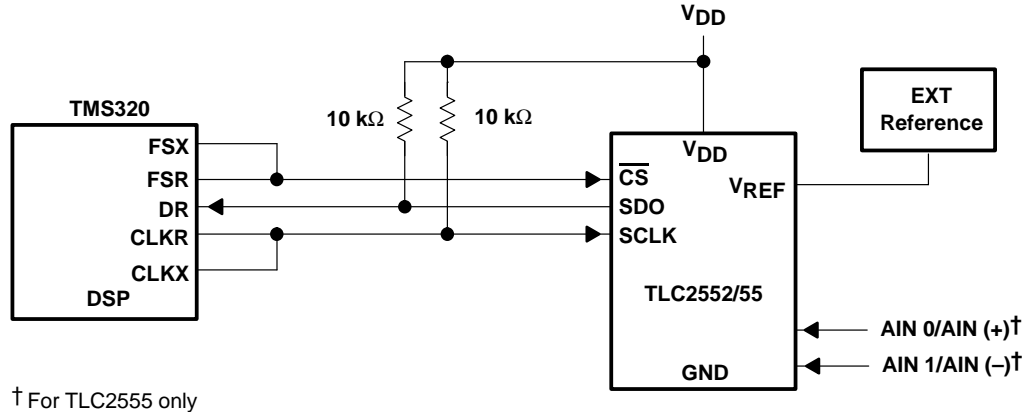

Figure 22. Typical TLC2552/55 Interface to a TMS320 DSP

**PACKAGING INFORMATION**

Orderable Device	Status (1)	Package Type	Package Drawing	Pins	Package Qty	Eco Plan (2)	Lead finish/ Ball material (6)	MSL Peak Temp (3)	Op Temp (°C)	Device Marking (4/5)	Samples
TLC2551CDGK	ACTIVE	VSSOP	DGK	8	80	RoHS & Green	NIPDAUAG	Level-1-260C-UNLIM	0 to 70	AHF	<a href="#">Samples</a>
TLC2551CDGKR	ACTIVE	VSSOP	DGK	8	2500	RoHS & Green	Call TI   NIPDAUAG	Level-1-260C-UNLIM	0 to 70	AHF	<a href="#">Samples</a>
TLC2551ID	ACTIVE	SOIC	D	8	75	RoHS & Green	NIPDAU	Level-1-260C-UNLIM	-40 to 85	2551I	<a href="#">Samples</a>
TLC2551IDGK	ACTIVE	VSSOP	DGK	8	80	RoHS & Green	NIPDAUAG	Level-1-260C-UNLIM	-40 to 85	AHG	<a href="#">Samples</a>
TLC2551IDR	ACTIVE	SOIC	D	8	2500	RoHS & Green	NIPDAU	Level-1-260C-UNLIM	-40 to 85	2551I	<a href="#">Samples</a>
TLC2552CDGK	ACTIVE	VSSOP	DGK	8	80	RoHS & Green	NIPDAUAG	Level-1-260C-UNLIM	0 to 70	AHH	<a href="#">Samples</a>
TLC2552ID	ACTIVE	SOIC	D	8	75	RoHS & Green	NIPDAU	Level-1-260C-UNLIM	-40 to 85	2552I	<a href="#">Samples</a>
TLC2552IDGK	ACTIVE	VSSOP	DGK	8	80	RoHS & Green	NIPDAUAG	Level-1-260C-UNLIM	-40 to 85	AHI	<a href="#">Samples</a>
TLC2555IDGK	ACTIVE	VSSOP	DGK	8	80	RoHS & Green	NIPDAUAG	Level-1-260C-UNLIM	-40 to 85	AHK	<a href="#">Samples</a>

(1) The marketing status values are defined as follows:

**ACTIVE:** Product device recommended for new designs.

**LIFEBUY:** TI has announced that the device will be discontinued, and a lifetime-buy period is in effect.

**NRND:** Not recommended for new designs. Device is in production to support existing customers, but TI does not recommend using this part in a new design.

**PREVIEW:** Device has been announced but is not in production. Samples may or may not be available.

**OBSOLETE:** TI has discontinued the production of the device.

(2) **RoHS:** TI defines "RoHS" to mean semiconductor products that are compliant with the current EU RoHS requirements for all 10 RoHS substances, including the requirement that RoHS substance do not exceed 0.1% by weight in homogeneous materials. Where designed to be soldered at high temperatures, "RoHS" products are suitable for use in specified lead-free processes. TI may reference these types of products as "Pb-Free".

**RoHS Exempt:** TI defines "RoHS Exempt" to mean products that contain lead but are compliant with EU RoHS pursuant to a specific EU RoHS exemption.

**Green:** TI defines "Green" to mean the content of Chlorine (Cl) and Bromine (Br) based flame retardants meet JS709B low halogen requirements of <=1000ppm threshold. Antimony trioxide based flame retardants must also meet the <=1000ppm threshold requirement.

(3) MSL, Peak Temp. - The Moisture Sensitivity Level rating according to the JEDEC industry standard classifications, and peak solder temperature.

(4) There may be additional marking, which relates to the logo, the lot trace code information, or the environmental category on the device.

<sup>(5)</sup> Multiple Device Markings will be inside parentheses. Only one Device Marking contained in parentheses and separated by a "~" will appear on a device. If a line is indented then it is a continuation of the previous line and the two combined represent the entire Device Marking for that device.

<sup>(6)</sup> Lead finish/Ball material - Orderable Devices may have multiple material finish options. Finish options are separated by a vertical ruled line. Lead finish/Ball material values may wrap to two lines if the finish value exceeds the maximum column width.

**Important Information and Disclaimer:**The information provided on this page represents TI's knowledge and belief as of the date that it is provided. TI bases its knowledge and belief on information provided by third parties, and makes no representation or warranty as to the accuracy of such information. Efforts are underway to better integrate information from third parties. TI has taken and continues to take reasonable steps to provide representative and accurate information but may not have conducted destructive testing or chemical analysis on incoming materials and chemicals. TI and TI suppliers consider certain information to be proprietary, and thus CAS numbers and other limited information may not be available for release.

In no event shall TI's liability arising out of such information exceed the total purchase price of the TI part(s) at issue in this document sold by TI to Customer on an annual basis.

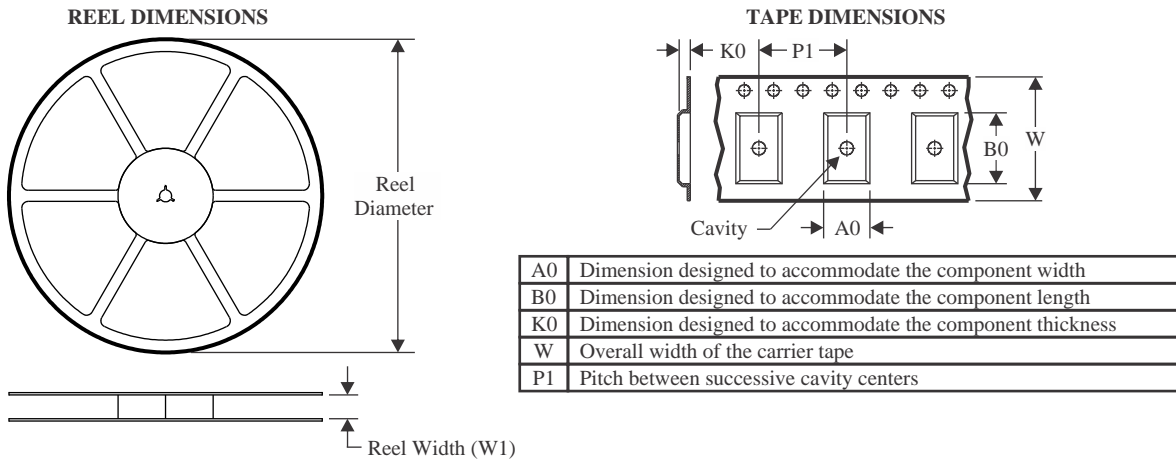
**TAPE AND REEL INFORMATION**

**QUADRANT ASSIGNMENTS FOR PIN 1 ORIENTATION IN TAPE**

\*All dimensions are nominal

Device	Package Type	Package Drawing	Pins	SPQ	Reel Diameter (mm)	Reel Width W1 (mm)	A0 (mm)	B0 (mm)	K0 (mm)	P1 (mm)	W (mm)	Pin1 Quadrant
TLC2551IDR	SOIC	D	8	2500	330.0	12.4	6.4	5.2	2.1	8.0	12.0	Q1

**TAPE AND REEL BOX DIMENSIONS**

\*All dimensions are nominal

Device	Package Type	Package Drawing	Pins	SPQ	Length (mm)	Width (mm)	Height (mm)
TLC2551IDR	SOIC	D	8	2500	350.0	350.0	43.0

**TUBE**

\*All dimensions are nominal

Device	Package Name	Package Type	Pins	SPQ	L (mm)	W (mm)	T (μm)	B (mm)
TLC2551CDGK	DGK	VSSOP	8	80	331.47	6.55	3000	2.88
TLC2551ID	D	SOIC	8	75	505.46	6.76	3810	4
TLC2551IDGK	DGK	VSSOP	8	80	331.47	6.55	3000	2.88
TLC2552CDGK	DGK	VSSOP	8	80	331.47	6.55	3000	2.88
TLC2552ID	D	SOIC	8	75	505.46	6.76	3810	4
TLC2552IDGK	DGK	VSSOP	8	80	331.47	6.55	3000	2.88
TLC2555IDGK	DGK	VSSOP	8	80	331.47	6.55	3000	2.88



D0008A

# PACKAGE OUTLINE

SOIC - 1.75 mm max height

SMALL OUTLINE INTEGRATED CIRCUIT



4214825/C 02/2019

### NOTES:

- Linear dimensions are in inches [millimeters]. Dimensions in parenthesis are for reference only. Controlling dimensions are in inches. Dimensioning and tolerancing per ASME Y14.5M.
- This drawing is subject to change without notice.
- This dimension does not include mold flash, protrusions, or gate burrs. Mold flash, protrusions, or gate burrs shall not exceed  $.006$  [0.15] per side.
- This dimension does not include interlead flash.
- Reference JEDEC registration MS-012, variation AA.

# EXAMPLE BOARD LAYOUT

D0008A

SOIC - 1.75 mm max height

SMALL OUTLINE INTEGRATED CIRCUIT



LAND PATTERN EXAMPLE  
 EXPOSED METAL SHOWN  
 SCALE:8X



SOLDER MASK DETAILS

4214825/C 02/2019

NOTES: (continued)

- 6. Publication IPC-7351 may have alternate designs.
- 7. Solder mask tolerances between and around signal pads can vary based on board fabrication site.

# EXAMPLE STENCIL DESIGN

D0008A

SOIC - 1.75 mm max height

SMALL OUTLINE INTEGRATED CIRCUIT



SOLDER PASTE EXAMPLE  
BASED ON .005 INCH [0.125 MM] THICK STENCIL  
SCALE:8X

4214825/C 02/2019

NOTES: (continued)

8. Laser cutting apertures with trapezoidal walls and rounded corners may offer better paste release. IPC-7525 may have alternate design recommendations.
9. Board assembly site may have different recommendations for stencil design.

# DGK0008A



# PACKAGE OUTLINE

VSSOP - 1.1 mm max height

SMALL OUTLINE PACKAGE



**NOTES:**

PowerPAD is a trademark of Texas Instruments.

1. All linear dimensions are in millimeters. Any dimensions in parenthesis are for reference only. Dimensioning and tolerancing per ASME Y14.5M.
2. This drawing is subject to change without notice.
3. This dimension does not include mold flash, protrusions, or gate burrs. Mold flash, protrusions, or gate burrs shall not exceed 0.15 mm per side.
4. This dimension does not include interlead flash. Interlead flash shall not exceed 0.25 mm per side.
5. Reference JEDEC registration MO-187.

# EXAMPLE BOARD LAYOUT

DGK0008A

™ VSSOP - 1.1 mm max height

SMALL OUTLINE PACKAGE



LAND PATTERN EXAMPLE  
EXPOSED METAL SHOWN  
SCALE: 15X

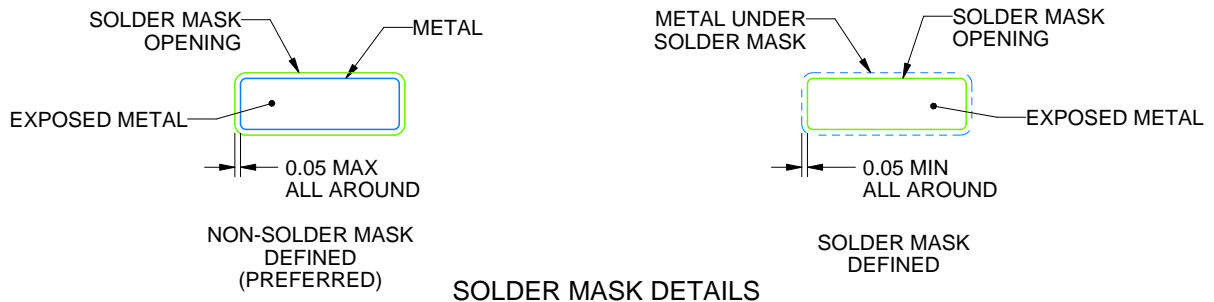

SOLDER MASK DETAILS

4214862/A 04/2023

NOTES: (continued)

6. Publication IPC-7351 may have alternate designs.
7. Solder mask tolerances between and around signal pads can vary based on board fabrication site.
8. Vias are optional depending on application, refer to device data sheet. If any vias are implemented, refer to their locations shown on this view. It is recommended that vias under paste be filled, plugged or tented.
9. Size of metal pad may vary due to creepage requirement.

# EXAMPLE STENCIL DESIGN

DGK0008A

<sup>TM</sup> VSSOP - 1.1 mm max height

SMALL OUTLINE PACKAGE



SOLDER PASTE EXAMPLE  
SCALE: 15X

4214862/A 04/2023

NOTES: (continued)

11. Laser cutting apertures with trapezoidal walls and rounded corners may offer better paste release. IPC-7525 may have alternate design recommendations.
12. Board assembly site may have different recommendations for stencil design.

## IMPORTANT NOTICE AND DISCLAIMER

TI PROVIDES TECHNICAL AND RELIABILITY DATA (INCLUDING DATA SHEETS), DESIGN RESOURCES (INCLUDING REFERENCE DESIGNS), APPLICATION OR OTHER DESIGN ADVICE, WEB TOOLS, SAFETY INFORMATION, AND OTHER RESOURCES "AS IS" AND WITH ALL FAULTS, AND DISCLAIMS ALL WARRANTIES, EXPRESS AND IMPLIED, INCLUDING WITHOUT LIMITATION ANY IMPLIED WARRANTIES OF MERCHANTABILITY, FITNESS FOR A PARTICULAR PURPOSE OR NON-INFRINGEMENT OF THIRD PARTY INTELLECTUAL PROPERTY RIGHTS.

These resources are intended for skilled developers designing with TI products. You are solely responsible for (1) selecting the appropriate TI products for your application, (2) designing, validating and testing your application, and (3) ensuring your application meets applicable standards, and any other safety, security, regulatory or other requirements.

These resources are subject to change without notice. TI grants you permission to use these resources only for development of an application that uses the TI products described in the resource. Other reproduction and display of these resources is prohibited. No license is granted to any other TI intellectual property right or to any third party intellectual property right. TI disclaims responsibility for, and you will fully indemnify TI and its representatives against, any claims, damages, costs, losses, and liabilities arising out of your use of these resources.

TI's products are provided subject to [TI's Terms of Sale](#) or other applicable terms available either on [ti.com](https://www.ti.com) or provided in conjunction with such TI products. TI's provision of these resources does not expand or otherwise alter TI's applicable warranties or warranty disclaimers for TI products.

TI objects to and rejects any additional or different terms you may have proposed.

Mailing Address: Texas Instruments, Post Office Box 655303, Dallas, Texas 75265  
Copyright © 2024, Texas Instruments Incorporated

## Looking for pricing, stock, or lifecycle information?

Click below to explore more details on WIN SOURCE:

 [View TLC2551IDR on WIN SOURCE](#)

 [Texas Instruments](#) Information

## Optimize Your Supply Chain with WIN SOURCE Solutions

-  Global Sourcing Solution
-  Obsolete Management
-  Cost Control Management
-  Shortage Management
-  Alternative Solution
-  Excess Inventory Management