



**THE DATASHEET OF  
TJA1081GTS/0Z**



# TJA1081G

## FlexRay node transceiver

Rev. 1 — 28 October 2016

Product data sheet

## 1. General description

---

The TJA1081G is a FlexRay transceiver that is fully compliant with FlexRay electrical physical layer specification ISO 17458-4:2013 (see [Ref. 1](#) and [Ref. 2](#)). It is intended for communication systems from 2.5 Mbit/s to 10 Mbit/s and provides an advanced interface between the protocol controller and the physical bus in a FlexRay network.

The TJA1081G features enhanced low-power modes, optimized for ECUs that are permanently connected to the battery.

The TJA1081G provides differential transmit capability to the network and differential receive capability to the FlexRay controller. It offers excellent EMC performance as well as effective ESD protection.

The TJA1081G actively monitors system performance using dedicated error and status information (that any microcontroller can read), along with internal voltage and temperature monitoring.

The TJA1081G supports mode control as used in the TJA1080A (see [Ref. 3](#)) and is fully functionally and pin compatible with the TJA1081B (see [Ref. 4](#)).

## 2. Features and benefits

---

### 2.1 Optimized for time triggered communication systems

- Compliant with ISO 17458-4:2013 (see [Ref. 2](#))
- Automotive product qualification in accordance with AEC-Q100
- Data transfer rates from 2.5 Mbit/s to 10 Mbit/s
- Very low ElectroMagnetic Emissions (EME) to support unshielded cable, meeting latest industry standards
- Differential receiver with wide common-mode range for high ElectroMagnetic Immunity (EMI), meeting latest industry standards
- Enhanced EMC performance compared with TJA1081B
- Auto I/O level adaptation to host controller supply voltage  $V_{IO}$
- Can be used in 14 V, 24 V and 48 V powered systems
- Instant transmitter shut-down interface (via BGE pin)
- Independent power supply ramp-up for  $V_{BAT}$ ,  $V_{CC}$  and  $V_{IO}$

### 2.2 Low-power management

- Low-power management including inhibit switch
- Very low current in Sleep and Standby modes



- $V_{BAT}$  operating range: 4.75 V to 60 V
- Gap-free specification
- Local and remote wake-up
- Supports remote wake-up via dedicated data frames
- Wake-up source recognition

### 2.3 Diagnosis (detection and signaling)

- Enhanced supply monitoring of  $V_{BAT}$ ,  $V_{CC}$  and  $V_{IO}$
- Overtemperature detection
- Short-circuit detection on bus lines
- $V_{BAT}$  power-on flag (first battery connection and cold start)
- Clamping diagnosis on pin TXEN
- BGE status feedback

### 2.4 Protection

- Bus pins protected against  $\pm 6$  kV ESD pulses according to IEC 61000-4-2 and HBM
- Pins  $V_{BAT}$  and WAKE protected against  $\pm 6$  kV ESD pulses according to IEC 61000-4-2
- Bus pins protected against transients in automotive environment (according to ISO 7637 class C)
- Bus pins short-circuit proof to battery voltage (14 V, 24 V and 48 V) and ground
- Fail-silent behavior in the event of an undervoltage on pins  $V_{BAT}$ ,  $V_{CC}$  or  $V_{IO}$
- Passive behavior of bus lines while the transceiver is not powered
- No reverse currents from the digital input pins to  $V_{IO}$  or  $V_{CC}$  when the transceiver is not powered

### 2.5 Functional classes according to FlexRay electrical physical layer specification (see [Ref. 2](#))

- Bus driver voltage regulator control
- Bus driver - bus guardian interface
- Bus driver logic level adaptation
- Bus driver remote wake-up

### 3. Quick reference data

Table 1. Quick reference data

Symbol	Parameter	Conditions	Min	Typ	Max	Unit
$V_{CC}$	supply voltage		4.75	-	5.25	V
$V_{uvd(VCC)}$	undervoltage detection voltage on pin $V_{CC}$		4.45	-	4.72	V
$I_{CC}$	supply current	Normal mode; $V_{BGE} = V_{IO}$ ; $V_{TXEN} = 0$ V	-	37	50	mA
$V_{BAT}$	battery supply voltage		4.75	-	60	V
$V_{uvd(VBAT)}$	undervoltage detection voltage on pin $V_{BAT}$		4.45	-	4.715	V
$I_{BAT}$	battery supply current	low-power modes; no load on pin INH	-	-	55	$\mu$ A
		normal-power modes	-	-	1	mA
$V_{IO}$	supply voltage on pin $V_{IO}$		2.8	-	5.25	V
$V_{uvd(VIO)}$	undervoltage detection voltage on pin $V_{IO}$		2.55	-	2.765	V
$I_{IO}$	supply current on pin $V_{IO}$	Normal and Receive-only modes; $V_{TXD} = V_{IO}$	-	-	1	mA
$V_{ESD}$	electrostatic discharge voltage	IEC 61000-4-2 on pins BP and BM to ground	-6	-	+6	kV

### 4. Ordering information

Table 2. Ordering information

Type number	Package		Version
	Name	Description	
TJA1081GTS	SSOP16	SSOP16: plastic shrink small outline package; 16 leads; body width 5.3 mm	SOT338-1

5. Block diagram

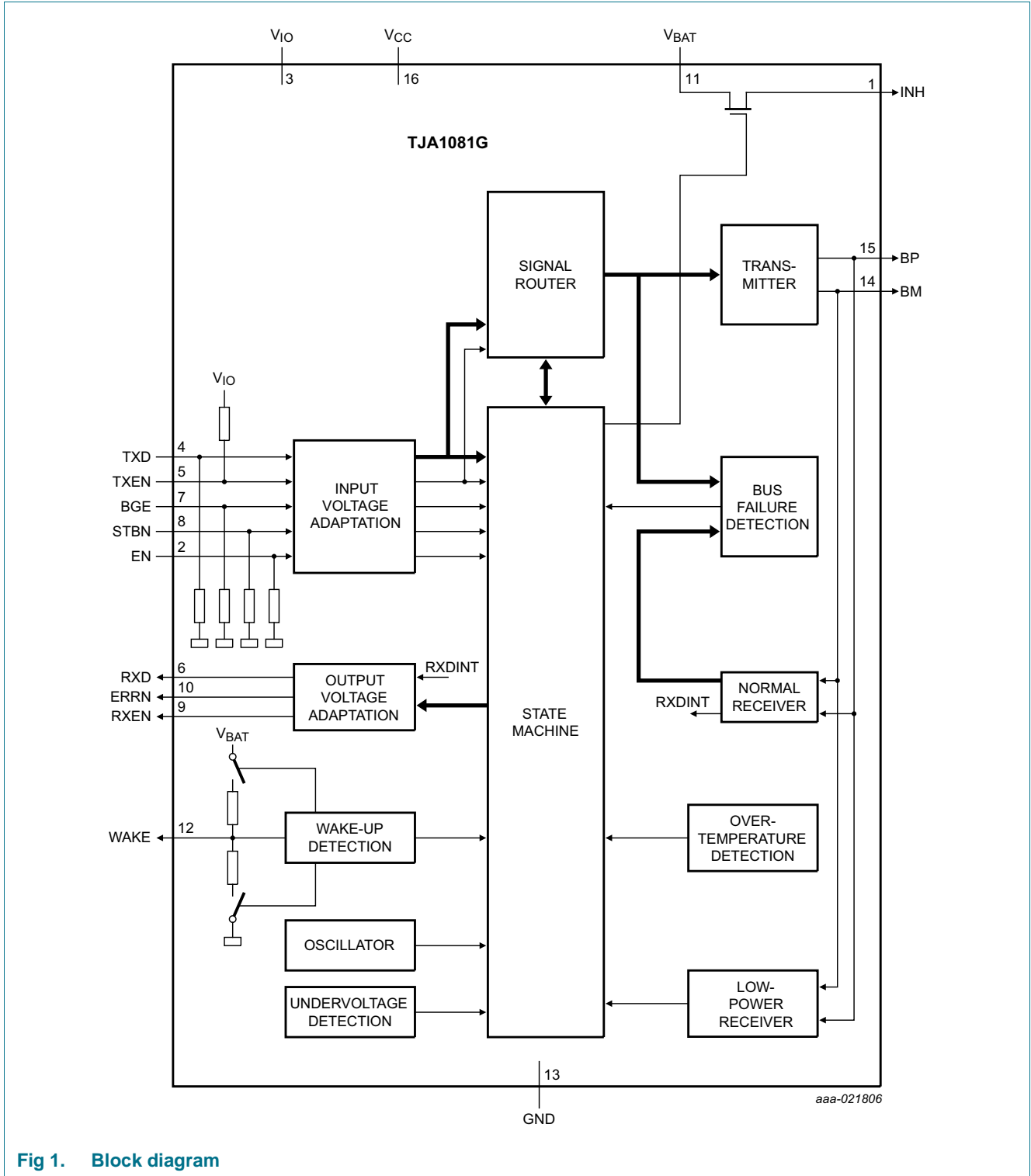

Fig 1. Block diagram

## 6. Pinning information

### 6.1 Pinning

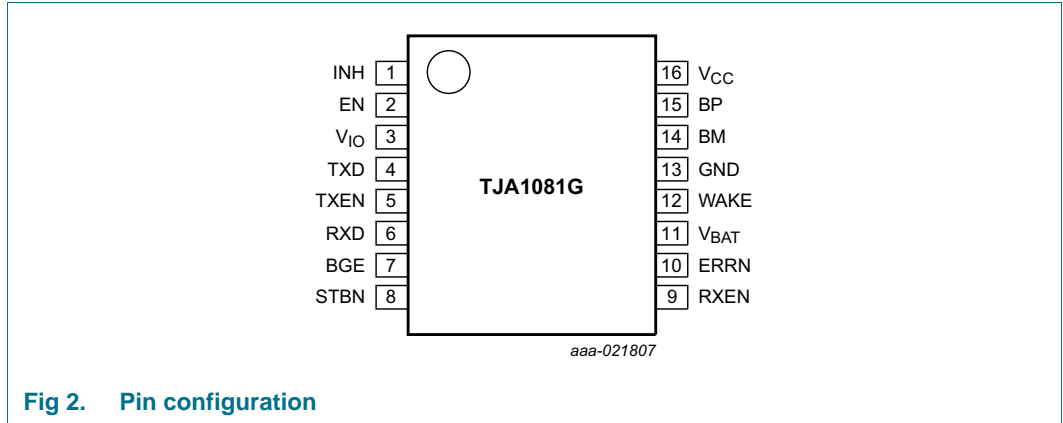

Fig 2. Pin configuration

### 6.2 Pin description

Table 3. Pin description

Symbol	Pin	Type <sup>[1]</sup>	Description
INH	1	AO	inhibit output for switching external voltage regulator
EN	2	I	enable input; enabled when HIGH; internal pull-down
V <sub>IO</sub>	3	P	supply voltage for V <sub>IO</sub> voltage level adaptation
TXD	4	I	transmit data input; internal pull-down
TXEN	5	I	transmitter enable input; when HIGH transmitter disabled; internal pull-up
RXD	6	O	receive data output
BGE	7	I	bus guardian enable input; when LOW transmitter disabled; internal pull-down
STBN	8	I	standby input; low-power mode when LOW; internal pull-down
RXEN	9	O	receive data enable output; when LOW bus activity detected
ERRN	10	O	error diagnoses output; when LOW error detected
V <sub>BAT</sub>	11	P	battery supply voltage
WAKE	12	AI	local wake-up input; internal pull-up or pull-down (depends on voltage at pin WAKE)
GND	13	G	ground
BM	14	AIO	bus line minus
BP	15	AIO	bus line plus
V <sub>CC</sub>	16	P	supply voltage (+5 V)

[1] AO: analog output; AI: analog input; I: digital input (V<sub>IO</sub> related); O: digital output (V<sub>IO</sub> related); I/O: digital input/output (V<sub>IO</sub> related); AIO: analog input/output; P: power supply; G: ground.

## 7. Functional description

The block diagram of the transceiver is shown in [Figure 1](#).

### 7.1 Operating modes

The TJA1081G supports the following operating modes:

- Normal (normal-power mode)
- Receive-only (normal-power mode)
- Standby (low-power mode)
- Go-to-sleep (low-power mode)
- Sleep (low-power mode)
- PowerOff

#### 7.1.1 Bus activity and idle detection

The following mechanisms for activity and idle detection are valid in normal power modes:

- If the absolute differential voltage on the bus lines is higher than  $|V_{i(dif)det(act)}|$  for  $t_{det(act)(bus)}$ , activity is detected on the bus lines. Pin RXEN is switched LOW, releasing pin RXD:
  - if, after activity has been detected on the bus, the differential voltage on the bus lines is lower than  $V_{IL(dif)}$ , pin RXD will go LOW
  - if, after activity has been detected on the bus, the differential voltage on the bus lines is higher than  $V_{IH(dif)}$ , pin RXD will go HIGH
- If the absolute differential voltage on the bus lines is lower than  $|V_{i(dif)det(act)}|$  for  $t_{det(idle)(bus)}$ , idle is detected on the bus lines. Pin RXEN is switched HIGH, blocking pin RXD (which is switched HIGH or remains HIGH)

### 7.1.2 Signaling on pin ERRN

Pin ERRN provides either error information or wake-up information. The behavior of ERRN is determined by the host (via pins STBN and EN) and not by the operating mode.

If STBN is LOW, pin ERRN is configured to signal a wake-up event. When STBN and EN are both HIGH, pin ERRN is configured to provide an error alert. Signaling on pin ERRN is described in [Table 4](#).

If pin ERRN goes LOW in Standby mode or Sleep mode to signal a wake-up event, the host can switch the TJA1081G to Receive only mode (STBN → H) to determine if the wake-up is local or remote. A LOW level on ERRN in Receive only mode (provided the transition to Receive only mode was not triggered by EN going LOW in Normal mode) indicates a remote wake-up was detected. A HIGH level on ERRN signals a local wake-up.

If EN had been forced HIGH after an earlier wake-up event (to switch the TJA1081G to Normal mode), ERRN will always indicate the error detection status (in both Normal and Receive only modes).

**Table 4. Signaling on pin ERRN**

STBN	EN	Conditions	ERRN
<b>Normal mode active</b>			
H	H	no error detected	HIGH
H	H	error detected	LOW
<b>Receive only mode active</b>			
H	L	a wake-up was detected (ERRN went LOW in Standby/Sleep mode; EN was LOW) before the TJA1081G was switched to Receive only mode	
		local wake-up detected	HIGH
		remote wake-up detected	LOW
H	L	EN was forced HIGH previously in response to an earlier wake-up event before the transition to Receive only mode	
		no error detected	HIGH
		error detected	LOW
<b>Standby or Sleep modes active</b>			
L	X	no local or remote wake-up detected	HIGH
L	X	local or remote wake-up detected	LOW

ERRN is in a high-impedance state in PowerOff mode.

### 7.1.3 Signaling on pins RXEN and RXD

The TJA1081G operating mode determines signaling on pins RXEN and RXD, as detailed in [Table 5](#).

**Table 5. RXEN and RXD signaling**

Operating mode	RXEN		RXD		Transmitter	INH
	LOW	HIGH	LOW	HIGH		
Normal	bus active	bus idle	DATA_0	DATA_1 or idle	enabled	HIGH
Receive-only					disabled	
Go-to-Sleep	local or remote wake-up detected <sup>[1]</sup>	no local or remote wake-up detected	local or remote wake-up detected <sup>[1]</sup>	no local or remote wake-up detected		
Standby						
Sleep						floating
PowerOff	high impedance		HIGH			

[1] Valid if V<sub>IO</sub> and (V<sub>CC</sub> or V<sub>BAT</sub>) are present.

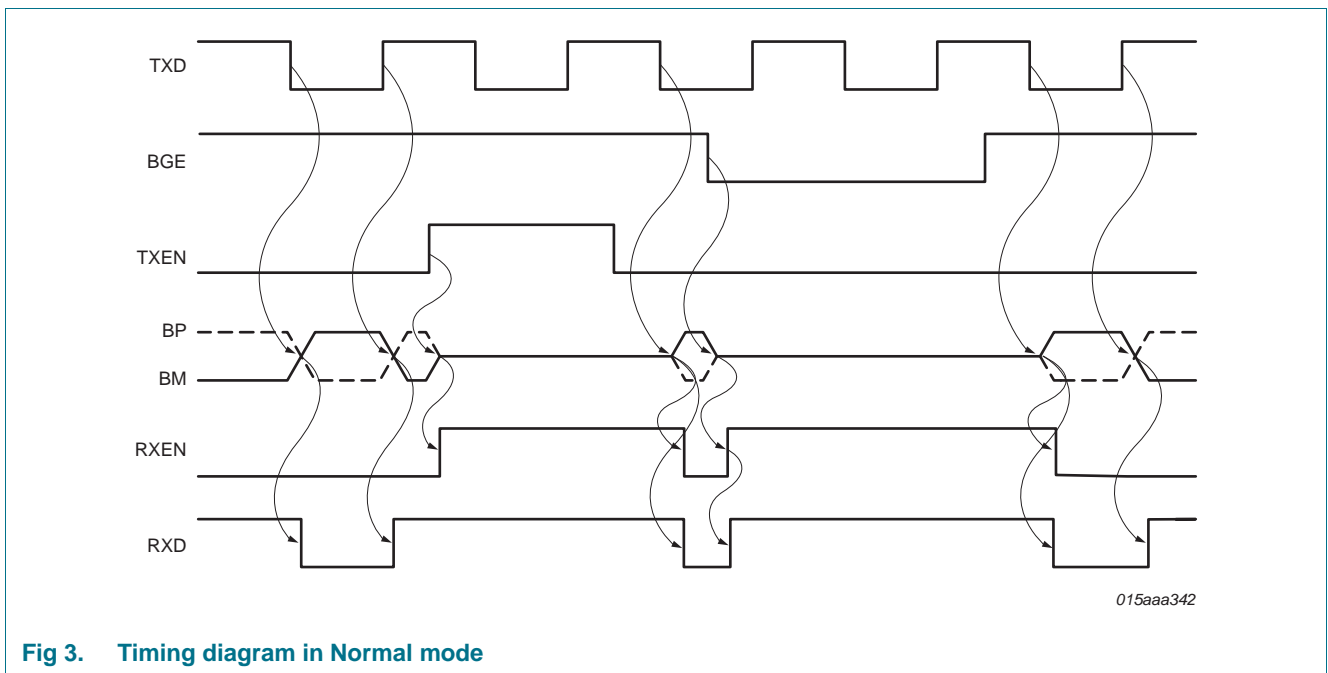

**Fig 3. Timing diagram in Normal mode**

7.1.4 Operating mode transitions

State transitions are summarized in the state transition diagram in Figure 4 and detailed in Table 6 to Table 9. Numbers are used to represent the state transitions. The numbers in the diagram correspond to the numbers in the third column in the tables.

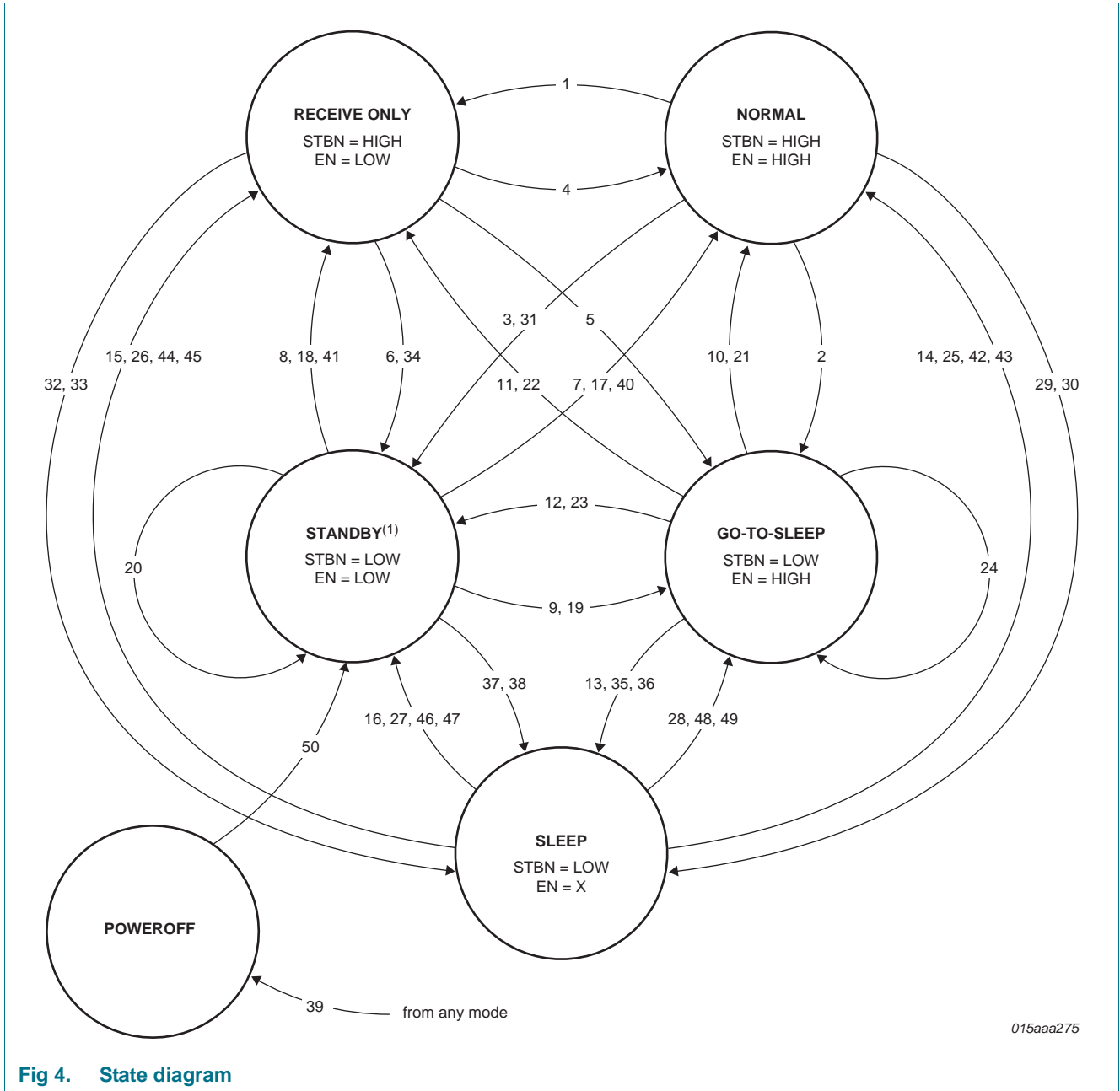

Fig 4. State diagram

**Table 6. State transitions forced by EN and STBN**

→ indicates the action that initiates a transaction; 1 → and 2 → indicated the consequences of a transaction.

Transition from mode	Direction to mode	Transition number	Pin		Flag			
			STBN	EN	UV_vio	UV_VBAT	UV_vcc	PWON
Normal	Receive-only	1	H	→ L	cleared	cleared	cleared	cleared
	Go-to-sleep	2	→ L	H	cleared	cleared	cleared	cleared
	Standby	3	→ L	→ L	cleared	cleared	cleared	cleared
Receive-only	Normal	4	H	→ H	cleared	cleared	cleared	X
	Go-to-sleep	5	→ L	→ H	cleared	cleared	cleared	X
	Standby	6	→ L	L	cleared	cleared	cleared	X
Standby	Normal	7	→ H	→ H	cleared	cleared	cleared	X
	Receive-only	8	→ H	L	cleared	cleared	cleared	X
	Go-to-sleep	9	L	→ H	cleared	cleared	X	X
Go-to-sleep	Normal	10	→ H	H	cleared	cleared	cleared	X
	Receive-only	11	→ H	→ L	cleared	cleared	cleared	X
	Standby	12	L	→ L	cleared	cleared	X	X
Sleep	Sleep	13	L	H	cleared	cleared	cleared	X
	Normal	14	→ H	H	cleared	cleared	cleared	X
	Receive-only	15	→ H	L	cleared	cleared	cleared	X
	Standby	16	→ H	X	cleared	cleared	X	X

[1] Hold time of go-to-sleep is less than  $t_{H(gotosleep)}$ .

[2] Hold time of go-to-sleep becomes greater than  $t_{H(gotosleep)}$ .

[3] Transition to a non-low-power mode is blocked when the voltage on pin V<sub>CC</sub> is below V<sub>uvd(VCC)</sub> for longer than t<sub>det(uv)(VCC)</sub>.

**Table 7. State transitions forced by a wake-up**

→ indicates the action that initiates a transaction; 1 → and 2 → indicated the consequences of a transaction.

Transition from mode	Direction to mode	Transition number	Pin		Flag			PWON
			STBN	EN	UV <sub>VI0</sub>	UV <sub>VBAT</sub>	UV <sub>VCC</sub>	
Standby	Normal	17	H	H	cleared	cleared	1 → cleared	X
	Receive-only	18	H	L	cleared	cleared	1 → cleared	X
	Go-to-sleep	19	L	H	cleared	cleared	1 → cleared	X
	Standby	20	L	L	cleared	cleared	1 → cleared	X
Go-to-sleep	Normal	21	H	H	cleared	cleared	1 → cleared	X
	Receive-only	22	H	L	cleared	cleared	1 → cleared	X
	Standby	23	L	L	cleared	cleared	1 → cleared	X
	Go-to-sleep	24	L	H	cleared	cleared	1 → cleared	X
Sleep	Normal	25	H	H	1 → cleared	1 → cleared	1 → cleared	X
	Receive-only	26	H	L	1 → cleared	1 → cleared	1 → cleared	X
	Standby	27	L	L	1 → cleared	1 → cleared	1 → cleared	X
	Go-to-sleep	28	L	H	1 → cleared	1 → cleared	1 → cleared	X

[1] Setting the wake flag clears the UV<sub>VI0</sub>, UV<sub>VBAT</sub> and UV<sub>VCC</sub> flags.

[2] Transition via Standby mode.

**Table 8. State transitions forced by an undervoltage condition**

→ indicates the action that initiates a transaction; 1 → and 2 → indicated the consequences of a transaction.

Transition from mode	Direction to mode	Transition number	Flag			
			UV <sub>VIO</sub>	UV <sub>VBAT</sub>	UV <sub>VCC</sub>	PWON
Normal	Sleep	29	→ set	cleared	cleared	cleared
	Sleep	30	cleared	→ set	cleared	cleared
	Standby	31	cleared	cleared	→ set	cleared
Receive-only	Sleep	32	→ set	cleared	cleared	X
	Sleep	33	cleared	→ set	cleared	X
	Standby	34	cleared	cleared	→ set	X
	Sleep	35	→ set	cleared	cleared	X
Go-to-sleep	Sleep	36	cleared	→ set	cleared	X
	Sleep	37	→ set	cleared	X	X
Standby	Sleep	38	cleared	→ set	X	X
	PowerOff	39	X	X	X	X

[1] UV<sub>VIO</sub>, UV<sub>VBAT</sub> or UV<sub>VCC</sub> detected clears the wake flag.

[2] Transition already completed when the voltage on pin V<sub>CC</sub> is below V<sub>uvd(VCC)</sub> for longer than t<sub>det(uv)(VCC)</sub>.

[3] UV<sub>VIO</sub> overrides UV<sub>VCC</sub>.

[4] UV<sub>VBAT</sub> overrides UV<sub>VCC</sub>.

[5] V<sub>BIG</sub> (the internal digital supply voltage to the state machine) < V<sub>th(det)POR</sub>.

**Table 9. State transitions forced by an undervoltage recovery**  
 → indicates the action that initiates a transaction; →1 and →2 are the consequences of a transaction.

Transition from mode	Direction to mode	Transition number	Pin		Flag			PWON	
			STBN	EN	UV <sub>VIO</sub>	UV <sub>VBAT</sub>	UV <sub>VCC</sub>		
Standby	Normal	40	H	H	cleared	cleared	cleared	→ cleared	X
	Receive-only	41	H	L	cleared	cleared	cleared	→ cleared	X
Sleep	Normal	42	H	H	cleared	→ cleared	cleared	cleared	X
	Normal	43	H	H	→ cleared	cleared	cleared	cleared	X
	Receive-only	44	H	L	cleared	→ cleared	cleared	cleared	X
	Receive-only	45	H	L	→ cleared	cleared	cleared	cleared	X
	Standby	46	L	L	cleared	→ cleared	cleared	cleared	X
	Standby	47	L	L	→ cleared	cleared	cleared	cleared	X
	Go-to-sleep	48	L	H	cleared	→ cleared	cleared	cleared	X
PowerOff	Go-to-sleep	49	L	H	→ cleared	cleared	cleared	cleared	X
	Standby	50	X	X	X	X	X	X	→ set

[1] Transition already completed when the voltage on pin V<sub>CC</sub> is above V<sub>uvr(VCC)</sub> for longer than t<sub>rec(uv)</sub>(VCC).

[2] The voltage on pin V<sub>BAT</sub> is above V<sub>uvr(VBAT)</sub> for longer than t<sub>rec(uv)</sub>(VBAT) AND V<sub>DIG</sub> (the internal digital supply voltage to the state machine) > V<sub>tr</sub>

### 7.1.5 Normal mode

In Normal mode, the transceiver is able to transmit and receive data via bus lines BP and BM. The output of the normal receiver is connected directly to pin RXD.

Transmitter behavior in Normal mode, with no TXEN timeout (see [Section 7.4.7](#)) and the temperature flag not set (TEMP HIGH = 0; see [Table 11](#)), is detailed in [Table 10](#).

In this mode, pin INH is set HIGH.

**Table 10. Transmitter function table**

BGE	TXEN	TXD	Transmitter
L	X	X	transmitter is disabled
X	H	X	transmitter is disabled
H	L	H	transmitter is enabled; the bus lines are actively driven; BP is driven HIGH and BM is driven LOW
H	L	L	transmitter is enabled; the bus lines are actively driven; BP is driven LOW and BM is driven HIGH

The first LOW level detected on pin TXD when pin BGE is HIGH and pin TXEN is LOW activates the transmitter.

### 7.1.6 Receive-only mode

In Receive-only mode, the transceiver can only receive data. The transmitter is disabled, regardless of the voltage levels on pins BGE and TXEN.

In this mode, pin INH is set HIGH.

### 7.1.7 Standby mode

Standby mode is a low-power mode featuring very low current consumption. In this mode, the transceiver cannot transmit or receive data. The low-power receiver is activated to monitor the bus for wake-up patterns.

A transition to Standby mode can be triggered by applying the appropriate levels on pins EN and STBN (see [Figure 4](#) and [Table 6](#)) or if an undervoltage is detected on pin V<sub>CC</sub> (see [Figure 4](#) and [Section 7.1.9](#)).

In this mode, pin INH is set HIGH.

If the wake flag is set, pins RXEN and RXD are driven LOW; otherwise pins RXEN and RXD are set HIGH (see [Section 7.2](#)).

### 7.1.8 Go-to-sleep mode

In this mode, the transceiver behaves as in Standby mode. If Go-to-sleep mode remains active longer than the go-to-sleep hold time ( $t_{h(\text{gotosleep})}$ ) and the wake flag has been cleared previously, the transceiver switches to Sleep mode regardless of the voltage on pin EN.

### 7.1.9 Sleep mode

Sleep mode is a low-power mode. The only difference between Sleep mode and Standby mode is that pin INH is set floating in Sleep mode. A transition to Sleep mode is triggered from all other modes when the UV<sub>VIO</sub> flag or the UV<sub>VBAT</sub> flag is set (see [Table 8](#)).

When the wake flag is set and  $V_{IO}$  is valid, the undervoltage flags are reset. The transceiver switches from Sleep mode to the mode indicated by the levels on pins EN and STBN (see [Table 8](#)).

## 7.2 Wake-up mechanism

From Sleep mode (pin INH floating), the transceiver enters Standby mode if the wake flag is set. Consequently, pin INH is switched on (HIGH).

If an undervoltage is not detected on pins  $V_{IO}$ ,  $V_{CC}$  or  $V_{BAT}$ , the transceiver switches immediately to the mode indicated by the levels on pins EN and STBN.

In Standby, Go-to-sleep and Sleep modes, pins RXD, RXEN and ERRN are driven LOW if the wake flag is set.

### 7.2.1 Remote wake-up

#### 7.2.1.1 Bus wake-up via wake-up pattern

A valid wake-up pattern on the bus triggers a remote wake-up. A valid remote wake-up pattern consists of a DATA\_0, DATA\_1 or idle, DATA\_0, DATA\_1 or idle sequence. The DATA\_0 phases must last at least  $t_{det(wake)DATA\_0}$  and the DATA\_1 or idle phases at least  $t_{det(wake)idle}$ . The entire sequence must be completed within  $t_{det(wake)tot}$ .

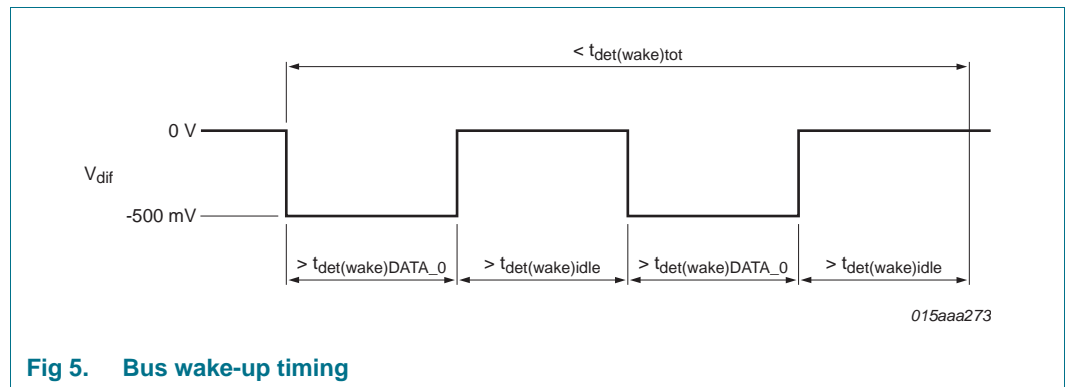

Fig 5. Bus wake-up timing

#### 7.2.1.2 Bus wake-up via dedicated FlexRay data frame

If the TJA1081G receives a dedicated data frame that emulates a valid wake-up pattern as detailed [Figure 6](#), the remote wake-up source flag is set.

Due to the Byte Start Sequence (BSS) preceding each byte, the DATA\_0 and DATA\_1 phases for the wake-up symbol are interrupted every 1  $\mu$ s. For 10 Mbit/s, the maximum interruption time is 130 ns. Such interruptions do not prevent the transceiver from recognizing the wake-up pattern in the payload of a data frame.

The remote wake-up source flag is not set if an invalid wake-up pattern is received.

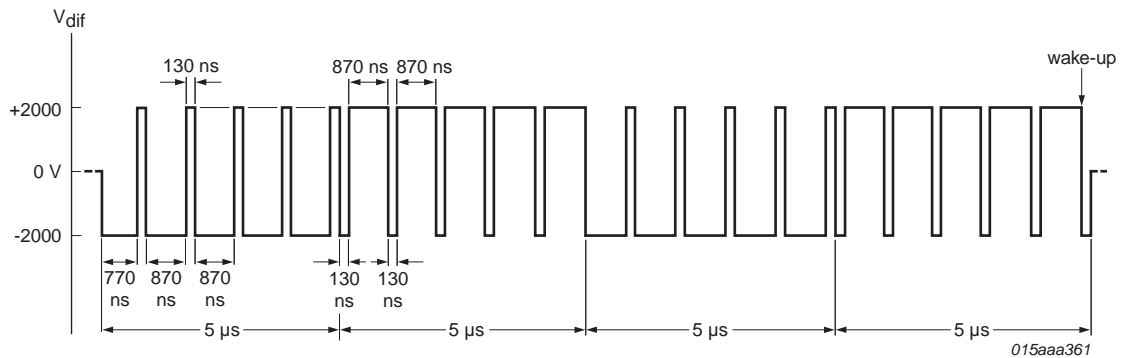

Each interruption is 130 ns.

The transition time from DATA\_0 to DATA\_1 and from DATA\_1 to DATA\_0 is about 20 ns.

The following pattern sets the TJA1081G remote wake-up source flag:

```
FFh, FFh, FFh, FFh, FFh, 00h, 00h, 00h, 00h, 00h,
FFh, FFh, FFh, FFh, FFh, 00h, 00h, 00h, 00h, 00h,
FFh, FFh, FFh, FFh, FFh, 00h, 00h, 00h, 00h, 00h,
FFh, FFh, FFh, FFh, FFh, FFh
```

Fig 6. Minimum bus pattern for bus wake-up

### 7.2.2 Local wake-up via pin WAKE

If the voltage on pin WAKE is lower than  $V_{th(det)(WAKE)}$  for longer than  $t_{ftr(WAKE)}$  (falling edge on pin WAKE), a local wake-up event on pin WAKE is detected. At the same time, the biasing of this pin is switched to pull-down.

If the voltage on pin WAKE is higher than  $V_{th(det)(WAKE)}$  for longer than  $t_{ftr(WAKE)}$ , the biasing of this pin is switched to pull up and a local wake-up is not detected.

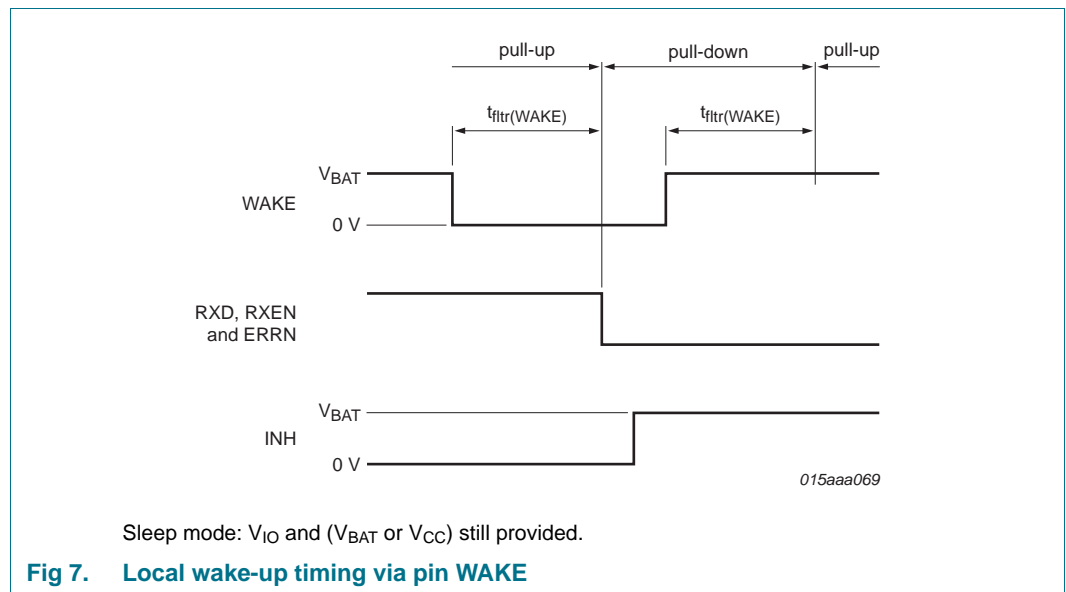

Fig 7. Local wake-up timing via pin WAKE

### 7.3 Fail-silent behavior

To ensure fail-silent behavior, a reset mechanism for the digital state machine has been implemented along with undervoltage detection.

If an undervoltage is detected on pins  $V_{CC}$ ,  $V_{IO}$  and/or  $V_{BAT}$ , the transceiver switches to a low-power mode. This action ensures that the transmitter and receiver are passive when an undervoltage is detected and that their behavior is defined.

The digital state machine is supplied by  $V_{CC}$ ,  $V_{IO}$  or  $V_{BAT}$ . Therefore, the digital state machine is properly supplied as long as the voltage on pin  $V_{CC}$ ,  $V_{IO}$  or  $V_{BAT}$  remains above 4.5 V.

If the voltage on all pins (i.e.  $V_{CC}$ ,  $V_{IO}$  and  $V_{BAT}$ ) breaks down, a reset signal is transmitted to the digital state machine. The reset signal is transmitted as soon as the internal supply voltage to the digital state machine is no longer high enough to guarantee proper operation. This precaution ensures that the digital state machine is passive, and its behavior defined, when an undervoltage is detected.

#### 7.3.1 $V_{BAT}$ undervoltage

If the  $UV_{V_{BAT}}$  flag is set, the transceiver enters Sleep mode (pin INH is switched off) regardless of the voltage levels on pins EN and STBN. If the undervoltage recovers, the transceiver switches to the mode determined by the voltages on pins EN and STBN.

#### 7.3.2 $V_{CC}$ undervoltage

If the  $UV_{V_{CC}}$  flag is set, the transceiver switches to Standby mode regardless of the voltage levels on pins EN and STBN. If the undervoltage recovers or the wake flag is set, mode switching via pins EN and STBN is again enabled.

#### 7.3.3 $V_{IO}$ undervoltage

If the voltage on pin  $V_{IO}$  is lower than  $V_{uvd(V_{IO})}$  for longer than  $t_{det(uv)(V_{IO})}$  (even if the  $UV_{V_{IO}}$  flag is reset) pins EN, STBN, TXD and BGE are set LOW (internally) and pin TXEN is set HIGH (internally). If the  $UV_{V_{IO}}$  flag is set, the transceiver enters Sleep mode (pin INH is switched off). If the undervoltage recovers or the wake flag is set, mode switching via pins EN and STBN is again enabled.

### 7.4 Flags

#### 7.4.1 Local wake-up source flag

The local wake-up source flag can only be set in a low-power mode. When a wake-up event is detected on pin WAKE (see [Section 7.2.2](#)), the local wake-up source flag is set. The local wake-up source flag is reset by entering a low-power mode.

#### 7.4.2 Remote wake-up source flag

The remote wake-up source flag can only be set in a low-power mode if pin  $V_{BAT}$  is within its operating range. When a remote wake-up event is detected on the bus lines (see [Section 7.2.1](#)), the remote wake-up source flag is set. The remote wake-up source flag is reset by entering a low-power mode.

### 7.4.3 Wake flag

The wake flag is set if the local or remote wake-up source flag is set. The wake flag is reset by entering a low-power mode or by setting one of the undervoltage flags.

### 7.4.4 Power-on flag

If the internal supply voltage to the digital section rises above the minimum operating level, the PWON power-on flag is set. The PWON flag is reset when the TJA1081G enters Normal mode.

### 7.4.5 Temperature medium flag

If the junction temperature exceeds  $T_{j(\text{warn})(\text{medium})}$  in a normal-power mode, the temperature medium flag is set. The temperature medium flag is reset when the junction temperature drops below  $T_{j(\text{warn})(\text{medium})}$  (in a normal-power mode or after the status register has been read in a low-power mode). No action is taken when this flag is set.

### 7.4.6 Temperature high flag

If the junction temperature exceeds  $T_{j(\text{dis})(\text{high})}$  in a normal-power mode, the temperature high flag is set. If a negative edge is applied to pin TXEN while the junction temperature is below  $T_{j(\text{dis})(\text{high})}$  in a normal-power mode, the temperature high flag is reset.

The transmitter is disabled when the temperature high flag is set.

### 7.4.7 TXEN clamped flag

If pin TXEN is LOW for longer than  $t_{\text{detCL}}(\text{TXEN})$ , the TXEN clamped flag is set. If pin TXEN is HIGH, the TXEN clamped flag is reset. The transmitter is disabled when the TXEN clamped flag is set.

### 7.4.8 Bus error flag

The bus error flag is set if pin TXEN is LOW, pin BGE is HIGH and the data received on the bus lines (pins BP and BM) is different to that received on pin TXD. The transmission of any valid communication element, including a wake-up pattern, is not detected as a bus error.

The bus error flag is reset if the data on the bus lines (pins BP and BM) is the same as on pin TXD or if the transmitter is disabled. No action is taken when the bus error flag is set.

### 7.4.9 UV<sub>V<sub>BAT</sub></sub> flag

If the voltage on pin V<sub>BAT</sub> is lower than  $V_{\text{uvd}}(\text{VBAT})$  for longer than  $t_{\text{det}(\text{uv})}(\text{VBAT})$ , the UV<sub>V<sub>BAT</sub></sub> flag is set. The UV<sub>V<sub>BAT</sub></sub> flag is reset if the voltage is higher than  $V_{\text{uvr}}(\text{VBAT})$  for longer than  $t_{\text{to}(\text{uvr})}(\text{VBAT})$  or by setting the wake flag; see [Section 7.3.1](#).

### 7.4.10 UV<sub>V<sub>CC</sub></sub> flag

In a non-low-power mode, the UV<sub>V<sub>CC</sub></sub> flag is set if the voltage on pin V<sub>CC</sub> is lower than  $V_{\text{uvd}}(\text{VCC})$  for longer than  $t_{\text{det}(\text{uv})}(\text{VCC})$ . In a low-power mode, the UV<sub>V<sub>CC</sub></sub> flag is set if the voltage on pin V<sub>CC</sub> is lower than  $V_{\text{uvd}}(\text{VCC})$  for longer than  $t_{\text{to}(\text{uvd})}(\text{VCC})$ . The UV<sub>V<sub>CC</sub></sub> flag is reset if the voltage on pin V<sub>CC</sub> is higher than  $V_{\text{uvr}}(\text{VCC})$  for longer than  $t_{\text{to}(\text{uvr})}(\text{VCC})$  or the wake flag is set; see [Section 7.3.2](#).

### 7.4.11 UV<sub>VIO</sub> flag

If the voltage on pin V<sub>IO</sub> is lower than V<sub>uvd(VIO)</sub> for longer than t<sub>to(ugd)(VIO)</sub>, the UV<sub>VIO</sub> flag is set. The UV<sub>VIO</sub> flag is reset if the voltage on pin V<sub>IO</sub> is higher than V<sub>uvr(VIO)</sub> for longer than t<sub>to(uvr)(VIO)</sub> or the wake flag is set; see [Section 7.3.3](#).

## 7.5 Status register

Pin ERRN goes LOW when one or more of status bits S4 to S10 is set. The contents of the status register ([Table 11](#)) can be read out on pin ERRN using the input signal on pin EN as a clock. The timing diagram is shown in [Figure 8](#).

The status register is accessible if:

- UV<sub>VIO</sub> flag is not set and the voltage on pin V<sub>IO</sub> is between 4.75 V and 5.25 V
- UV<sub>VCC</sub> flag is not set and the voltage on pin V<sub>IO</sub> is between 2.8 V and 4.75 V

If an edge is not detected on pin EN for t<sub>det(EN)</sub> after reading the status register, status bits S4 to S10 are cleared provided the corresponding flags have been reset.

**Table 11. Status bits**

Bit number	Status bit	Description
S0	LOCAL WAKEUP	local wake-up source flag is redirected to this bit
S1	REMOTE WAKEUP	remote wake-up source flag is redirected to this bit
S2	-	not used; always set
S3	PWON	status bit set means that PWON flag has been set previously
S4	BUS ERROR	status bit set means that bus error flag has been set previously
S5	TEMP HIGH	status bit set means temperature high flag has been set previously
S6	TEMP MEDIUM	status bit set means that temperature medium flag has been set previously
S7	TXEN CLAMPED	status bit set means that TXEN clamped flag has been set previously
S8	UVVBAT	status bit set means UV <sub>VBAT</sub> flag has been set previously
S9	UVVCC	status bit set means UV <sub>VCC</sub> flag has been set previously
S10	UVVIO	status bit set means UV <sub>VIO</sub> flag has been set previously
S11	BGE FEEDBACK	BGE feedback (status bit reset if pin BGE LOW; status bit set if pin BGE HIGH)
S12	-	not used; always reset

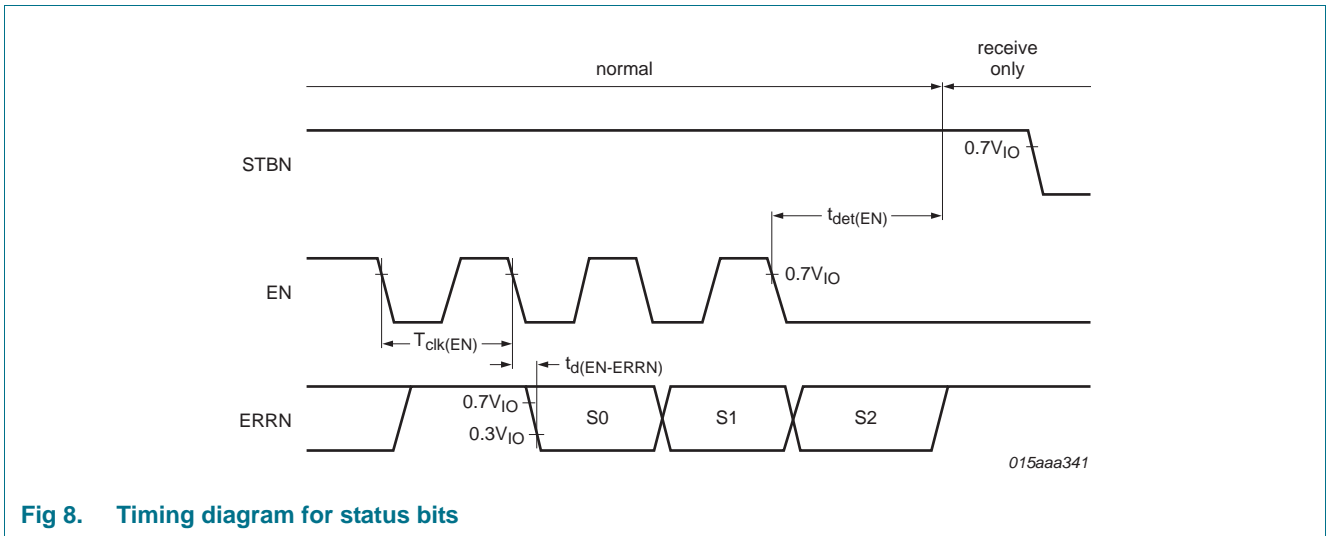

Fig 8. Timing diagram for status bits

## 8. Limiting values

**Table 12. Limiting values**

In accordance with the Absolute Maximum Rating System (IEC 60134). All voltages are referenced to ground.

Symbol	Parameter	Conditions	Min	Max	Unit
V <sub>x</sub>	voltage on pin x	on pin V <sub>BAT</sub> [1]	-0.3	+60	V
		on pins V <sub>CC</sub> , V <sub>IO</sub> , BGE, TXEN, TXD, EN and STBN [1]	-0.3	+5.5	V
		on pins INH, WAKE [1]	-0.3	V <sub>BAT</sub> + 0.3	V
		on pins ERRN, RXD and RXEN [1]	-0.3	V <sub>IO</sub> + 0.3	V
		on pins BP and BM with respect to pins V <sub>BAT</sub> , WAKE, INH, GND and each other [1]	-60	+60	V
I <sub>O(INH)</sub>	output current on pin INH		-1	-	mA
I <sub>O(WAKE)</sub>	output current on pin WAKE	pin GND not connected	-15	-	mA
V <sub>trt</sub>	transient voltage	on pins BM and BP [2]			
		pulse 1	-100	-	V
		pulse 2a	-	75	V
		pulse 3a	-150	-	V
		pulse 3b	-	100	V
T <sub>stg</sub>	storage temperature		-55	+150	°C
T <sub>vj</sub>	virtual junction temperature	[3]	-40	+150	°C
T <sub>amb</sub>	ambient temperature		-40	+125	°C
V <sub>ESD</sub>	electrostatic discharge voltage	IEC 61000-4-2 (150 pF, 330 Ω) [4]			
		on pins BP and BM to ground	-6.0	+6.0	kV
		on pin V <sub>BAT</sub> to ground [5]	-6.0	+6.0	kV
		on pin WAKE to ground [6]	-6.0	+6.0	kV
		Human Body Model (HBM); 100 pF, 1.5 kΩ [7]			
		on pins BP and BM to ground	-6.0	+6.0	kV
		on pins V <sub>BAT</sub> and WAKE to ground	-4.0	+4.0	kV
		on any other pin	-2.0	+2.0	kV
		Machine Model (MM); 200 pF, 0.75 μH, 10 Ω; any pin [8]	-100	+100	V
		Charged Device Model (CDM); field induced charge; 4 pF [9]			
		on corner pins	-750	+750	V
on any other pin	-500	+500	V		

- [1] The device can sustain voltages up to the specified values over the product lifetime, provided applied voltages (including transients) never exceed these values.
- [2] According to TS 62228 (2007), Section 4.2.4; parameters for standard pulses defined in ISO 7637-2:2004-09-15.
- [3] In accordance with IEC 60747-1. An alternative definition of T<sub>vj</sub> is: T<sub>vj</sub> = T<sub>amb</sub> + P × R<sub>th(j-a)</sub>, where R<sub>th(j-a)</sub> is a fixed value to be used for the calculation of T<sub>vj</sub>. The rating for T<sub>vj</sub> limits the allowable combinations of power dissipation (P) and ambient temperature (T<sub>amb</sub>).
- [4] According to TS 62228 (2007), Section 4.3; DIN EN IEC 61000-4-2.
- [5] With 100 nF from V<sub>BAT</sub> to GND.
- [6] With 3.3 kΩ in series.
- [7] According to AEC-Q100-002.
- [8] According to AEC-Q100-003.
- [9] According to AEC-Q100-011 Rev-C1. The classification level is C4B.

## 9. Thermal characteristics

Table 13. Thermal characteristics

Symbol	Parameter	Conditions	Typ	Unit
R <sub>th(j-a)</sub>	thermal resistance from junction to ambient	dual-layer board	[1] 96	K/W
		four-layer board	[2] 72	K/W

- [1] According to JEDEC JESD51-2, JESD51-3 and JESD51-5 at natural convection on 1s board with thermal via array under the exposed pad connected to the second copper layer.
- [2] According to JEDEC JESD51-2, JESD51-5 and JESD51-7 at natural convection on 2s2p board. Board with two inner copper layers (thickness: 35 μm) and thermal via array under the exposed pad connected to the first inner copper layer.

## 10. Static characteristics

Table 14. Static characteristics

All parameters are guaranteed for  $V_{BAT} = 4.45\text{ V to }60\text{ V}$ ;  $V_{CC} = 4.45\text{ V to }5.25\text{ V}$ ;  $V_{IO} = 2.55\text{ V to }5.25\text{ V}$ ;  $T_{vj} = -40\text{ °C to }+150\text{ °C}$ ;  $C_{bus} = 100\text{ pF}$ ;  $R_{bus} = 40\text{ }\Omega\text{ to }55\text{ }\Omega$  unless otherwise specified. All voltages are defined with respect to ground; positive currents flow into the IC.

Symbol	Parameter	Conditions	Min	Typ	Max	Unit
<b>Pin V<sub>BAT</sub></b>						
V <sub>BAT</sub>	battery supply voltage		4.75	-	60	V
I <sub>BAT</sub>	battery supply current	low-power modes; no load on pin INH	-	-	55	μA
		normal-power modes	-	-	1	mA
V <sub>uvd(VBAT)</sub>	undervoltage detection voltage on pin V <sub>BAT</sub>		4.45	-	4.715	V
V <sub>uvr(VBAT)</sub>	undervoltage recovery voltage on pin V <sub>BAT</sub>		4.475	-	4.74	V
V <sub>uvhys(VBAT)</sub>	undervoltage hysteresis voltage on pin V <sub>BAT</sub>		25	-	290	mV
<b>Pin V<sub>CC</sub></b>						
V <sub>CC</sub>	supply voltage		4.75	-	5.25	V
I <sub>CC</sub>	supply current	low-power modes	-1	+2	+10	μA
		Normal mode; V <sub>BGE</sub> = 0 V; V <sub>TXEN</sub> = V <sub>IO</sub> ; Receive-only mode	-	13	21	mA
		Normal mode; V <sub>BGE</sub> = V <sub>IO</sub> ; V <sub>TXEN</sub> = 0 V	-	37	50	mA
		Normal mode; V <sub>BGE</sub> = V <sub>IO</sub> ; V <sub>TXEN</sub> = 0 V; R <sub>bus</sub> = ∞ Ω	-	14	22	mA
V <sub>uvd(VCC)</sub>	undervoltage detection voltage on pin V <sub>CC</sub>		4.45	-	4.72	V
V <sub>uvr(VCC)</sub>	undervoltage recovery voltage on pin V <sub>CC</sub>		4.47	-	4.74	V
V <sub>uvhys(VCC)</sub>	undervoltage hysteresis voltage on pin V <sub>CC</sub>		20	-	290	mV
<b>Pin V<sub>IO</sub></b>						
V <sub>IO</sub>	supply voltage on pin V <sub>IO</sub>		2.8	-	5.25	V

**Table 14. Static characteristics ...continued**

All parameters are guaranteed for  $V_{BAT} = 4.45\text{ V to }60\text{ V}$ ;  $V_{CC} = 4.45\text{ V to }5.25\text{ V}$ ;  $V_{IO} = 2.55\text{ V to }5.25\text{ V}$ ;  $T_{vj} = -40\text{ °C to }+150\text{ °C}$ ;  $C_{bus} = 100\text{ pF}$ ;  $R_{bus} = 40\text{ }\Omega\text{ to }55\text{ }\Omega$  unless otherwise specified. All voltages are defined with respect to ground; positive currents flow into the IC.

Symbol	Parameter	Conditions	Min	Typ	Max	Unit
$I_{IO}$	supply current on pin $V_{IO}$	low-power modes; $V_{TXEN} = V_{IO}$	-1	+2	+10	$\mu\text{A}$
		Normal and Receive-only modes; $V_{TXD} = V_{IO}$	-	-	1	$\text{mA}$
$I_{R(VIO)}$	reverse current on pin $V_{IO}$	from digital input pins; PowerOff mode; $V_{TXEN} = 5.25\text{ V}$ ; $V_{TXD} = 5.25\text{ V}$ ; $V_{BGE} = 5.25\text{ V}$ ; $V_{EN} = 5.25\text{ V}$ ; $V_{STBN} = 5.25\text{ V}$ ; $V_{CC} = V_{IO} = 0\text{ V}$	-5	-	+5	$\mu\text{A}$
$V_{uvd(VIO)}$	undervoltage detection voltage on pin $V_{IO}$		2.55	-	2.765	V
$V_{uvr(VIO)}$	undervoltage recovery voltage on pin $V_{IO}$		2.575	-	2.79	V
$V_{uvhys(VIO)}$	undervoltage hysteresis voltage on pin $V_{IO}$		25	-	240	$\text{mV}$
<b>Pin EN</b>						
$V_{IH}$	HIGH-level input voltage		$0.7V_{IO}$	-	5.5	V
$V_{IL}$	LOW-level input voltage		-0.3	-	$0.3V_{IO}$	V
$I_{IH}$	HIGH-level input current	$V_{EN} = 0.7V_{IO}$	3	-	15	$\mu\text{A}$
$I_{IL}$	LOW-level input current	$V_{EN} = 0\text{ V}$	-1	0	+1	$\mu\text{A}$
<b>Pin STBN</b>						
$V_{IH}$	HIGH-level input voltage		$0.7V_{IO}$	-	5.5	V
$V_{IL}$	LOW-level input voltage		-0.3	-	$0.3V_{IO}$	V
$I_{IH}$	HIGH-level input current	$V_{STBN} = 0.7V_{IO}$	3	-	15	$\mu\text{A}$
$I_{IL}$	LOW-level input current	$V_{STBN} = 0\text{ V}$	-1	0	+1	$\mu\text{A}$
<b>Pin TXEN</b>						
$V_{IH}$	HIGH-level input voltage		$0.7V_{IO}$	-	5.5	V
$V_{IL}$	LOW-level input voltage		-0.3	-	$0.3V_{IO}$	V
$I_{IH}$	HIGH-level input current	$V_{TXEN} = V_{IO}$	-1	0	+1	$\mu\text{A}$
$I_{IL}$	LOW-level input current	$V_{TXEN} = 0.3V_{IO}$	-300	-	-50	$\mu\text{A}$
$I_L$	leakage current	$V_{TXEN} = 5.25\text{ V}$ ; $V_{IO} = 0\text{ V}$	-1	0	+1	$\mu\text{A}$
<b>Pin BGE</b>						
$V_{IH}$	HIGH-level input voltage		$0.7V_{IO}$	-	5.5	V
$V_{IL}$	LOW-level input voltage		-0.3	-	$0.3V_{IO}$	V
$I_{IH}$	HIGH-level input current	$V_{BGE} = 0.7V_{IO}$	3	-	15	$\mu\text{A}$
$I_{IL}$	LOW-level input current	$V_{BGE} = 0\text{ V}$	-1	0	+1	$\mu\text{A}$
<b>Pin TXD</b>						
$V_{IH}$	HIGH-level input voltage	normal-power modes	$0.6V_{IO}$	-	$V_{IO} + 0.3$	V
$V_{IL}$	LOW-level input voltage	normal-power modes	-0.3	-	$0.4V_{IO}$	V
$I_{IH}$	HIGH-level input current	$V_{TXD} = V_{IO}$	3	-	15	$\mu\text{A}$

**Table 14. Static characteristics ...continued**

All parameters are guaranteed for  $V_{BAT} = 4.45\text{ V to }60\text{ V}$ ;  $V_{CC} = 4.45\text{ V to }5.25\text{ V}$ ;  $V_{IO} = 2.55\text{ V to }5.25\text{ V}$ ;  $T_{vj} = -40\text{ }^{\circ}\text{C to }+150\text{ }^{\circ}\text{C}$ ;  $C_{bus} = 100\text{ pF}$ ;  $R_{bus} = 40\text{ }\Omega\text{ to }55\text{ }\Omega$  unless otherwise specified. All voltages are defined with respect to ground; positive currents flow into the IC.

Symbol	Parameter	Conditions	Min	Typ	Max	Unit
$I_{IL}$	LOW-level input current	normal-power modes; $V_{TXD} = 0\text{ V}$	-5	0	+5	$\mu\text{A}$
		low-power modes	-1	0	+1	$\mu\text{A}$
$I_{LI}$	input leakage current	$V_{TXD} = 5.25\text{ V}$ ; $V_{IO} = 0\text{ V}$	-1	0	+1	$\mu\text{A}$
$C_i$	input capacitance	not tested; with respect to all other pins at ground; $V_{TXD} = 100\text{ mV}$ ; $f = 5\text{ MHz}$	[1] -	5	10	pF
<b>Pin RXD</b>						
$I_{OH}$	HIGH-level output current	$V_{RXD} = V_{IO} - 0.4\text{ V}$ ; $V_{IO} = V_{CC}$	-20	-	-1	mA
$I_{OL}$	LOW-level output current	$V_{RXD} = 0.4\text{ V}$	1	-	20	mA
$V_{OH}$	HIGH-level output voltage	$I_{OH(RXD)} = -1\text{ mA}$	[1] $V_{IO} - 0.4$	-	$V_{IO}$	V
$V_{OL}$	LOW-level output voltage	$I_{OL(RXD)} = 1\text{ mA}$	[1] -	-	0.4	V
$V_O$	output voltage	when undervoltage on $V_{IO}$ ; $V_{CC} \geq 4.75\text{ V}$ ; $R_L = 100\text{ k}\Omega$ to ground	-	-	0.5	V
		$R_L = 100\text{ k}\Omega$ to $V_{IO}$ ; power off	$V_{IO} - 0.5$	-	$V_{IO}$	V
<b>Pin ERRN</b>						
$I_{OH}$	HIGH-level output current	$V_{ERRN} = V_{IO} - 0.4\text{ V}$ ; $V_{IO} = V_{CC}$	-8	-3	-0.5	mA
$I_{OL}$	LOW-level output current	$V_{ERRN} = 0.4\text{ V}$	0.5	2	8	mA
$V_{OH}$	HIGH-level output voltage	$I_{OH(ERRN)} = -0.5\text{ mA}$	[1] $V_{IO} - 0.4$	-	$V_{IO}$	V
$V_{OL}$	LOW-level output voltage	$I_{OL(ERRN)} = 0.5\text{ mA}$	[1] -	-	0.4	V
$I_L$	leakage current	$0\text{ V} \leq V_{ERRN} \leq V_{IO}$ ; power off	-5	0	+5	$\mu\text{A}$
$V_O$	output voltage	when undervoltage on $V_{IO}$ ; $V_{CC} > 4.75\text{ V}$ ; $R_L = 100\text{ k}\Omega$ to ground	-	-	0.5	V
		$R_L = 100\text{ k}\Omega$ to ground; power off	-	-	0.5	V
<b>Pin RXEN</b>						
$I_{OH}$	HIGH-level output current	$V_{RXEN} = V_{IO} - 0.4\text{ V}$ ; $V_{IO} = V_{CC}$	-8	-3	-0.5	mA
$I_{OL}$	LOW-level output current	$V_{RXEN} = 0.4\text{ V}$	0.5	2	8	mA
$V_{OH}$	HIGH-level output voltage	$I_{OH(RXEN)} = -0.5\text{ mA}$	[1] $V_{IO} - 0.4$	-	$V_{IO}$	V
$V_{OL}$	LOW-level output voltage	$I_{OL(RXEN)} = 0.5\text{ mA}$	[1] -	-	0.4	V
$I_L$	leakage current	$0\text{ V} \leq V_{RXEN} \leq V_{IO}$ ; power off	-5	0	+5	$\mu\text{A}$

**Table 14. Static characteristics ...continued**

All parameters are guaranteed for  $V_{BAT} = 4.45\text{ V to }60\text{ V}$ ;  $V_{CC} = 4.45\text{ V to }5.25\text{ V}$ ;  $V_{IO} = 2.55\text{ V to }5.25\text{ V}$ ;  $T_{vj} = -40\text{ °C to }+150\text{ °C}$ ;  $C_{bus} = 100\text{ pF}$ ;  $R_{bus} = 40\text{ }\Omega\text{ to }55\text{ }\Omega$  unless otherwise specified. All voltages are defined with respect to ground; positive currents flow into the IC.

Symbol	Parameter	Conditions	Min	Typ	Max	Unit
$V_O$	output voltage	when undervoltage on $V_{IO}$ ; $V_{CC} > 4.75\text{ V}$ ; $R_L = 100\text{ k}\Omega$ to ground	-	-	0.5	V
		$R_L = 100\text{ k}\Omega$ to $V_{IO}$ ; power off	$V_{IO} - 0.5$	-	$V_{IO}$	V
<b>Pins BP and BM</b>						
$V_{o(idle)(BP)}$	idle output voltage on pin BP	Normal or Receive-only mode; $V_{TXEN} = V_{IO}$ ; $4.5\text{ V} \leq V_{CC} \leq 5.25\text{ V}$	$0.4V_{CC}$	$0.5V_{CC}$	$0.6V_{CC}$	V
		Standby, Go-to-sleep or Sleep mode	-0.1	0	+0.1	V
$V_{o(idle)(BM)}$	idle output voltage on pin BM	Normal or Receive-only mode; $V_{TXEN} = V_{IO}$ ; $4.5\text{ V} \leq V_{CC} \leq 5.25\text{ V}$	$0.4V_{CC}$	$0.5V_{CC}$	$0.6V_{CC}$	V
		Standby, Go-to-sleep or Sleep mode	-0.1	0	+0.1	V
$I_{o(idle)BP}$	idle output current on pin BP	$-60\text{ V} \leq V_{BP} \leq +60\text{ V}$ ; with respect to ground and $V_{BAT}$	-7.5	-	+7.5	mA
$I_{o(idle)BM}$	idle output current on pin BM	$-60\text{ V} \leq V_{BM} \leq +60\text{ V}$ ; with respect to ground and $V_{BAT}$	-7.5	-	+7.5	mA
$V_{o(idle)(dif)}$	differential idle output voltage		[2] -25	0	+25	mV
$V_{OH(dif)}$	differential HIGH-level output voltage	$4.75\text{ V} \leq V_{CC} \leq 5.25\text{ V}$	[2] 600	-	2000	mV
		$4.45\text{ V} \leq V_{CC} \leq 5.25\text{ V}$	[2] 530	-	2000	mV
$V_{OL(dif)}$	differential LOW-level output voltage	$4.75\text{ V} \leq V_{CC} \leq 5.25\text{ V}$	[2] -2000	-	-600	mV
		$4.45\text{ V} \leq V_{CC} \leq 5.25\text{ V}$	[2] -2000	-	-530	mV
$V_{IH(dif)}$	differential HIGH-level input voltage	normal-power modes; $-10\text{ V} \leq V_{cm} \leq +15\text{ V}$ ; see <a href="#">Figure 10</a>	[3] [4] 150	210	300	mV
		normal-power modes; $-10\text{ V} \leq V_{cm} \leq +15\text{ V}$ ; see <a href="#">Figure 10</a>	[3] [4] -300	-210	-150	mV
$V_{IL(dif)}$	differential LOW-level input voltage	normal-power modes; $-10\text{ V} \leq V_{cm} \leq +15\text{ V}$ ; see <a href="#">Figure 10</a>	[3] [4] -300	-210	-150	mV
		low-power modes; see <a href="#">Figure 10</a>	[4] -400	-300	-100	mV
$ \Delta V_{i(dif)(H-L)} $	differential input volt. diff. betw. HIGH- and LOW-levels (abs. value)	normal-power modes; $V_{cm} = 2.5\text{ V}$	[4] -30	-	+30	mV
$ V_{i(dif)det(act)} $	activity detection differential input voltage (absolute value)	normal-power modes	150	210	300	mV

**Table 14. Static characteristics ...continued**

All parameters are guaranteed for  $V_{BAT} = 4.45\text{ V to }60\text{ V}$ ;  $V_{CC} = 4.45\text{ V to }5.25\text{ V}$ ;  $V_{IO} = 2.55\text{ V to }5.25\text{ V}$ ;  $T_{vj} = -40\text{ }^{\circ}\text{C to }+150\text{ }^{\circ}\text{C}$ ;  $C_{bus} = 100\text{ pF}$ ;  $R_{bus} = 40\text{ }\Omega\text{ to }55\text{ }\Omega$  unless otherwise specified. All voltages are defined with respect to ground; positive currents flow into the IC.

Symbol	Parameter	Conditions	Min	Typ	Max	Unit	
$I_{O(sc)}$	short-circuit output current (absolute value)	on pin BP; $-5\text{ V} \leq V_{BP} \leq +60\text{ V}$ $R_{sc} \leq 1\text{ }\Omega$ ; $t_{sc} \geq 1500\text{ }\mu\text{s}$	[5] [6]	-	-	60	mA
		on pin BM; $-5\text{ V} \leq V_{BM} \leq +60\text{ V}$ $R_{sc} \leq 1\text{ }\Omega$ ; $t_{sc} \geq 1500\text{ }\mu\text{s}$	[5] [6]	-	-	60	mA
		on pins BP and BM; $R_{sc} \leq 1\text{ }\Omega$ ; $t_{sc} \geq 1500\text{ }\mu\text{s}$ ; $V_{BP} = V_{BM}$	[5] [6]	-	-	60	mA
$R_{i(BP)}$	input resistance on pin BP	idle level; $R_{bus} = \infty\text{ }\Omega$	10	18	40	k $\Omega$	
$R_{i(BM)}$	input resistance on pin BM	idle level; $R_{bus} = \infty\text{ }\Omega$	10	18	40	k $\Omega$	
$R_{i(dif)(BP-BM)}$	differential input resistance between pin BP and pin BM	idle level; $R_{bus} = \infty\text{ }\Omega$	20	36	80	k $\Omega$	
$I_{L(BP)}$	input leakage current on pin BP	power off; $V_{BP} = V_{BM} = 5\text{ V}$ ; all other pins connected to GND; GND connected to 0 V		-5	0	+5	$\mu\text{A}$
		loss of ground; $V_{BP} = V_{BM} = 0\text{ V}$ ; all other pins connected to 16 V via 0 $\Omega$	[1]	-1600		+1600	$\mu\text{A}$
$I_{L(BM)}$	input leakage current on pin BM	power off; $V_{BP} = V_{BM} = 5\text{ V}$ ; all other pins connected to GND; GND connected to 0 V		-5	0	+5	$\mu\text{A}$
		loss of ground; $V_{BP} = V_{BM} = 0\text{ V}$ ; all other pins connected to 16 V via 0 $\Omega$	[1]	-1600		+1600	$\mu\text{A}$
$V_{cm(bus)(DATA_0)}$	DATA_0 bus common-mode voltage		$0.4V_{CC}$	$0.5V_{CC}$	$0.6V_{CC}$	V	
$V_{cm(bus)(DATA_1)}$	DATA_1 bus common-mode voltage		$0.4V_{CC}$	$0.5V_{CC}$	$0.6V_{CC}$	V	
$\Delta V_{cm(bus)}$	bus common-mode voltage difference		-30	0	+30	mV	
$C_{i(BP)}$	input capacitance on pin BP	with respect to all other pins at ground; $V_{BP} = 100\text{ mV}$ ; $f = 5\text{ MHz}$	[1]	-	8	15	pF
$C_{i(BM)}$	input capacitance on pin BM	with respect to all other pins at ground; $V_{BM} = 100\text{ mV}$ ; $f = 5\text{ MHz}$	[1]	-	8	15	pF
$C_{i(dif)(BP-BM)}$	differential input capacitance between pin BP and pin BM	with respect to all other pins at ground; $V_{(BM-BP)} = 100\text{ mV}$ ; $f = 5\text{ MHz}$	[1]	-	2	5	pF
$Z_{o(eq)TX}$	transmitter equivalent output impedance	Normal mode; $R_{bus} = 40\text{ }\Omega\text{ or }100\text{ }\Omega$ ; $C_{bus} = 100\text{ pF}$	[1] [7]	35	-	100	$\Omega$

**Table 14. Static characteristics ...continued**

All parameters are guaranteed for  $V_{BAT} = 4.45\text{ V to }60\text{ V}$ ;  $V_{CC} = 4.45\text{ V to }5.25\text{ V}$ ;  $V_{IO} = 2.55\text{ V to }5.25\text{ V}$ ;  $T_{vj} = -40\text{ °C to }+150\text{ °C}$ ;  $C_{bus} = 100\text{ pF}$ ;  $R_{bus} = 40\text{ }\Omega\text{ to }55\text{ }\Omega$  unless otherwise specified. All voltages are defined with respect to ground; positive currents flow into the IC.

Symbol	Parameter	Conditions	Min	Typ	Max	Unit
<b>Pin INH</b>						
$V_{OH(INH)}$	HIGH-level output voltage on pin INH	$I_{INH} = -0.2\text{ mA}$	$V_{BAT} - 0.8$	$V_{BAT} - 0.3$	$V_{BAT}$	V
		$I_{INH} = -1\text{ mA}$ ; $V_{BAT} \geq 5.5\text{ V}$	$V_{BAT} - 4$	-	$V_{BAT}$	V
$I_{L(INH)}$	leakage current on pin INH	Sleep mode	-5	0	+5	$\mu\text{A}$
$I_{OL(INH)}$	LOW-level output current on pin INH	$V_{INH} = 0\text{ V}$	-7	-4	-1	mA
<b>Pin WAKE</b>						
$V_{th(det)(WAKE)}$	detection threshold voltage on pin WAKE	low-power mode	2	-	3.75	V
$V_{hys}$	hysteresis voltage		0.3	-	1.2	V
$I_{IL}$	LOW-level input current	$V_{WAKE} = 2\text{ V}$ for $t > t_{ftr(WAKE)}$	3	-	11	$\mu\text{A}$
		$V_{WAKE} = 0\text{ V}$	-2	-	-0.3	$\mu\text{A}$
$I_{IH}$	HIGH-level input current	$V_{WAKE} = 3.75\text{ V}$ for $t > t_{ftr(WAKE)}$ ; $4.75\text{ V} \leq V_{BAT} \leq 60\text{ V}$	-11	-	-3	$\mu\text{A}$
		$V_{WAKE} = V_{BAT}$	0.2	-	2	$\mu\text{A}$
<b>Temperature protection</b>						
$T_{j(warn)(medium)}$	medium warning junction temperature	$V_{BAT} > 5.5\text{ V}$	155	165	175	$^{\circ}\text{C}$
$T_{j(dis)(high)}$	high disable junction temperature	$V_{BAT} > 5.5\text{ V}$	180	190	200	$^{\circ}\text{C}$
<b>Power-on reset</b>						
$V_{th(det)POR}$	power-on reset detection threshold voltage	of internal digital circuitry	3.0	-	3.4	V
$V_{th(rec)POR}$	power-on reset recovery threshold voltage	of internal digital circuitry	3.1	-	3.5	V
$V_{hys(POR)}$	power-on reset hysteresis voltage	of internal digital circuitry	100	-	500	mV

- [1] Not tested in production; guaranteed by design.
- [2] Values also guaranteed when the signal on TXD is constant for between 100 ns and 4400 ns before the first edge.
- [3] Activity detected previously.
- [4]  $V_{cm}$  is the BP/BM common mode voltage.
- [5]  $R_{sc}$  is the short-circuit resistance; voltage difference between bus pins BP and BM is 60 V max.
- [6]  $t_{sc}$  is the minimum duration of the short circuit.
- [7]  $Z_{o(eq)TX} = 50\text{ }\Omega \times (V_{bus(100)} - V_{bus(40)}) / (2.5 \times V_{bus(40)} - V_{bus(100)})$  where:
  - $V_{bus(100)}$  is the differential output voltage on a load of 100  $\Omega$  and 100 pF in parallel
  - $V_{bus(40)}$  is the differential output voltage on a load of 40  $\Omega$  and 100 pF in parallel when driving a DATA\_1.

## 11. Dynamic characteristics

**Table 15. Dynamic characteristics**

All parameters are guaranteed for  $V_{BAT} = 4.45\text{ V to }60\text{ V}$ ;  $V_{CC} = 4.45\text{ V to }5.25\text{ V}$ ;  $V_{IO} = 2.55\text{ V to }5.25\text{ V}$ ;  $T_{vj} = -40\text{ }^{\circ}\text{C to }+150\text{ }^{\circ}\text{C}$ ;  $C_{bus} = 100\text{ pF}$ ;  $R_{bus} = 40\text{ }\Omega\text{ to }55\text{ }\Omega$  unless otherwise specified. All voltages are defined with respect to ground; positive currents flow into the IC.

Symbol	Parameter	Conditions	Min	Typ	Max	Unit	
<b>Pins BP and BM</b>							
$t_{d(\text{TXD-bus})}$	delay time from TXD to bus	Normal mode; see <a href="#">Figure 9</a>	[1] [2]				
		DATA_0		-	-	60	ns
		DATA_1		-	-	60	ns
$\Delta t_{d(\text{TXD-bus})}$	delay time difference from TXD to bus	Normal mode; between DATA_0 and DATA_1; see <a href="#">Figure 10</a>	[1] [2] [3]	-4	-	+4	ns
$t_{d(\text{bus-RXD})}$	delay time from bus to RXD	Normal mode; $V_{cm} = 2.5\text{ V}$ ; $C_{RXD} = 25\text{ pF}$ ; see <a href="#">Figure 10</a>	[3]				
		DATA_0		-	-	75	ns
		DATA_1		-	-	75	ns
$\Delta t_{d(\text{bus-RXD})}$	delay time difference from bus to RXD	Normal mode; $V_{cm} = 2.5\text{ V}$ ; $C_{RXD} = 25\text{ pF}$ ; between DATA_0 and DATA_1; see <a href="#">Figure 10</a>	[3]	-5	-	+5	ns
$t_{d(\text{TXEN-busidle})}$	delay time from TXEN to bus idle	Normal mode; see <a href="#">Figure 9</a>		-	50	75	ns
$t_{d(\text{TXEN-busact})}$	delay time from TXEN to bus active	Normal mode; see <a href="#">Figure 9</a>		-	51	75	ns
$\Delta t_{d(\text{TXEN-bus})}$	delay time difference from TXEN to bus	Normal mode; between TXEN-to-bus active and TXEN-to-bus idle; TXD LOW; see <a href="#">Figure 9</a>		-50	-	+50	ns
$t_{d(\text{BGE-busidle})}$	delay time from BGE to bus idle	Normal mode; see <a href="#">Figure 9</a>		-	50	75	ns
$t_{d(\text{BGE-busact})}$	delay time from BGE to bus active	Normal mode; see <a href="#">Figure 9</a>		-	53	75	ns
$t_{d(\text{TXENH-RXDH})}$	delay time from TXEN HIGH to RXD HIGH	Normal mode; TXD LOW		-	-	325	ns
<b>Bus slope</b>							
$t_{r(\text{dif})(\text{bus})}$	bus differential rise time	20 % to 80 %	[1]	6	-	18.75	ns
		DATA_0 to idle; -300 mV to -30 mV; Normal mode		-	-	30	ns
$t_{f(\text{dif})(\text{bus})}$	bus differential fall time	80 % to 20 %	[1]	6	-	18.75	ns
		idle to DATA_0; -30 mV to -300 mV; Normal mode		-	-	30	ns
		DATA_1 to idle; 300 mV to 30 mV; Normal mode		-	-	30	ns
$\Delta t_{(r-f)(\text{dif})}$	difference between differential rise and fall time	80 % to 20 %		-3	-	+3	ns

**Table 15. Dynamic characteristics ...continued**

All parameters are guaranteed for  $V_{BAT} = 4.45\text{ V to }60\text{ V}$ ;  $V_{CC} = 4.45\text{ V to }5.25\text{ V}$ ;  $V_{IO} = 2.55\text{ V to }5.25\text{ V}$ ;  $T_{vj} = -40\text{ }^{\circ}\text{C to }+150\text{ }^{\circ}\text{C}$ ;  $C_{bus} = 100\text{ pF}$ ;  $R_{bus} = 40\text{ }\Omega\text{ to }55\text{ }\Omega$  unless otherwise specified. All voltages are defined with respect to ground; positive currents flow into the IC.

Symbol	Parameter	Conditions	Min	Typ	Max	Unit
<b>Pin RXD</b>						
$t_r$	rise time	$C_{RXD} = 15\text{ pF}$ ; 20 % to 80 %	-	-	9	ns
		$C_{RXD} = 25\text{ pF}$ ; 20 % to 80 %	-	-	10.75	
$t_f$	fall time	$C_{RXD} = 15\text{ pF}$ ; 80 % to 20 %	-	-	9	ns
		$C_{RXD} = 25\text{ pF}$ ; 80 % to 20 %	-	-	10.75	
$t_{(r+f)}$	sum of rise and fall time	$C_{RXD} = 15\text{ pF}$ ; 20 % to 80 % and 80 % to 20 %	-	-	13	ns
		$C_{RXD} = 25\text{ pF}$ ; 20 % to 80 % and 80 % to 20 %	-	-	16.5	ns
		$C_{RXD} = 10\text{ pF}$ load at end of $50\text{ }\Omega$ $\mu$ strip with 1 ns delay; 20 % to 80 % and 80 % to 20 %; simulation only	-	-	16.5	ns
$\Delta t_{(r-f)}$	difference between rise and fall time	$C_{RXD} = 15\text{ pF}$ ; 20 % to 80 %	-5	-	+5	ns
		$C_{RXD} = 25\text{ pF}$ ; 20 % to 80 %	-5	-	+5	ns
		$C_{RXD} = 10\text{ pF}$ load at end of $50\text{ }\Omega$ $\mu$ strip with 1 ns delay; 20 % to 80 % and 80 % to 20 %; simulation only	-5	-	+5	ns
<b>WAKE symbol detection</b>						
$t_{det(wake)DATA\_0}$	DATA_0 wake-up detection time	Standby or Sleep mode; $-10\text{ V} \leq V_{cm} \leq +15\text{ V}$	1	-	4	$\mu$ s
$t_{det(wake)idle}$	idle wake-up detection time		1	-	4	$\mu$ s
$t_{det(wake)tot}$	total wake-up detection time		50	-	115	$\mu$ s
$t_{sup(int)wake}$	wake-up interruption suppression time		[4]	130	-	1000
<b>Reaction time</b>						
$t_{d(wakedet-INHH)}$	delay time from wake-up detection to INH HIGH	low-power mode; $R_{L(INH-GND)} = 100\text{ k}\Omega$ ; $V_{INH} = 2\text{ V}$	-	-	35	$\mu$ s
$t_{d(event-ERRNL)}$	delay time from event detection to ERRN LOW	low-power mode	-	-	10	$\mu$ s
$t_{d(wakedet-RXDL)}$	delay time from wake-up detection to RXD LOW	low-power mode	-	-	10	$\mu$ s
$t_{d(STBNX-moch)}$	delay time from STBN changing to mode change		-	-	100	$\mu$ s
$t_{d(ENX-moch)}$	delay time from EN changing to mode change		-	-	100	$\mu$ s
<b>Undervoltage detection</b>						
$t_{det(uv)(VCC)}$	undervoltage detection time on pin $V_{CC}$	$V_{CC} = 4.35\text{ V}$	5	-	100	$\mu$ s
$t_{to(uvd)(VCC)}$	undervoltage detection time-out time on pin $V_{CC}$		100	-	670	ms
$t_{rec(uv)(VCC)}$	undervoltage recovery time on pin $V_{CC}$	$V_{CC} = 4.85\text{ V}$	5	-	100	$\mu$ s
$t_{to(uvr)(VCC)}$	undervoltage recovery time-out time on pin $V_{CC}$		1	-	5.2	ms

**Table 15. Dynamic characteristics ...continued**

All parameters are guaranteed for  $V_{BAT} = 4.45\text{ V to }60\text{ V}$ ;  $V_{CC} = 4.45\text{ V to }5.25\text{ V}$ ;  $V_{IO} = 2.55\text{ V to }5.25\text{ V}$ ;  $T_{vj} = -40\text{ °C to }+150\text{ °C}$ ;  $C_{bus} = 100\text{ pF}$ ;  $R_{bus} = 40\text{ }\Omega\text{ to }55\text{ }\Omega$  unless otherwise specified. All voltages are defined with respect to ground; positive currents flow into the IC.

Symbol	Parameter	Conditions	Min	Typ	Max	Unit
$t_{det(uv)(VIO)}$	undervoltage detection time on pin $V_{IO}$	$V_{IO} = 2.45\text{ V}$	5	-	100	$\mu\text{s}$
$t_{to(ugd)(VIO)}$	undervoltage detection time-out time on pin $V_{IO}$		100	-	670	ms
$t_{rec(uv)(VIO)}$	undervoltage recovery time on pin $V_{IO}$	$V_{IO} = 2.9\text{ V}$	5	-	100	$\mu\text{s}$
$t_{to(uvr)(VIO)}$	undervoltage recovery time-out time on pin $V_{IO}$		1	-	5.2	ms
$t_{det(uv)(VBAT)}$	undervoltage detection time on pin $V_{BAT}$	$V_{BAT} = 4.35\text{ V}$	5	-	100	$\mu\text{s}$
$t_{rec(uv)(VBAT)}$	undervoltage recovery time on pin $V_{BAT}$	$V_{BAT} = 4.85\text{ V}$	5	-	100	$\mu\text{s}$
$t_{to(uvr)(VBAT)}$	undervoltage recovery time-out time on pin $V_{BAT}$		1	-	5.2	ms
<b>Activity detection</b>						
$t_{det(act)(bus)}$	activity detection time on bus pins	$V_{dif}: 0\text{ mV} \rightarrow 400\text{ mV}$ ; $V_{cm} = 2.5\text{ V}$ ;	100	-	200	ns
$t_{det(idle)(bus)}$	idle detection time on bus pins	$V_{dif}: 400\text{ mV} \rightarrow 0\text{ mV}$ ; $V_{cm} = 2.5\text{ V}$ ;	50	-	200	ns
$\Delta t_{det(act-idle)}$	difference between active and idle detection time	$V_{cm} = 2.5\text{ V}$	-75	-	+75	ns
<b>Mode control pins</b>						
$t_d(STBN-RXD)$	STBN to RXD delay time	STBN HIGH to RXD HIGH; remote or local wake-up source flag set	3	-	12	$\mu\text{s}$
$t_{ftr}(STBN)$	filter time on pin STBN	rising and falling edges	3	-	10	$\mu\text{s}$
$t_d(STBN-stb)$	delay time from STBN to standby mode	STBN LOW to Standby mode; Receive-only mode	<a href="#">5</a>	-	10	$\mu\text{s}$
$t_h(gotosleep)$	go-to-sleep hold time		20	35	50	$\mu\text{s}$
<b>Status register</b>						
$t_{det}(EN)$	detection time on pin EN	for mode control	5	-	20	$\mu\text{s}$
$T_{clk}(EN)$	clock period on pin EN	EN signal used as clock for reading status bits; see <a href="#">Figure 8</a>	1	-	5	$\mu\text{s}$
$t_d(EN-ERRN)$	delay time from EN to ERRN	when reading status bits; see <a href="#">Figure 8</a>	-	-	0.5	$\mu\text{s}$
<b>Pin WAKE</b>						
$t_{ftr}(WAKE)$	filter time on pin WAKE	low-power modes; falling edge on pin WAKE; $5.5\text{ V} \leq V_{BAT} \leq 27\text{ V}$	2.9	-	100	$\mu\text{s}$
		low-power modes; falling edge on pin WAKE; $27\text{ V} \leq V_{BAT} \leq 60\text{ V}$	2.9	-	175	$\mu\text{s}$

**Table 15. Dynamic characteristics ...continued**

All parameters are guaranteed for  $V_{BAT} = 4.45\text{ V to }60\text{ V}$ ;  $V_{CC} = 4.45\text{ V to }5.25\text{ V}$ ;  $V_{IO} = 2.55\text{ V to }5.25\text{ V}$ ;  $T_{vj} = -40\text{ }^{\circ}\text{C to }+150\text{ }^{\circ}\text{C}$ ;  $C_{bus} = 100\text{ pF}$ ;  $R_{bus} = 40\text{ }\Omega\text{ to }55\text{ }\Omega$  unless otherwise specified. All voltages are defined with respect to ground; positive currents flow into the IC.

Symbol	Parameter	Conditions	Min	Typ	Max	Unit
<b>Miscellaneous</b>						
$t_{detCL}(TXEN)$	TXEN clamp detection time		650	-	2600	$\mu\text{s}$
$t_{d(busact-RXDL)}$	delay time from bus active to RXD LOW	Normal mode; $V_{cm} = 2.5\text{ V}$ ; $C_{RXD} = 25\text{ pF}$ ; see <a href="#">Figure 9</a>	[6] [7]	100	-	275 ns
$t_{d(busidle-RXDH)}$	delay time from bus idle to RXD HIGH	Normal mode; $V_{cm} = 2.5\text{ V}$ ; $C_{RXD} = 25\text{ pF}$ ; see <a href="#">Figure 9</a>	[6] [8]	100	-	275 ns

- [1] Values also guaranteed when the signal on TXD is constant for between 100 ns and 4400 ns before the first edge.
- [2] Sum of rise and fall times on TXD (20 % to 80 % on  $V_{IO}$ ) is 9 ns (max).
- [3] Guaranteed for  $V_{bus(dif)} = \pm 300\text{ mV}$  and  $V_{bus(dif)} = \pm 150\text{ mV}$ ;  $V_{bus(dif)}$  is the differential bus voltage  $V_{BP} - V_{BM}$ .
- [4] The minimum value is guaranteed when the phase that was interrupted was present continuously for at least 870 ns.
- [5] The same parameter is guaranteed by design for the transition from Normal to Go-to-sleep mode.
- [6] Not tested in production; guaranteed by design.
- [7]  $t_{d(busact-RXDL)} = t_{d(bus-RXD)} + t_{det(act)(bus)}$ .
- [8]  $t_{d(busidle-RXDH)} = t_{d(bus-RXD)} + t_{det(idle)(bus)}$ .

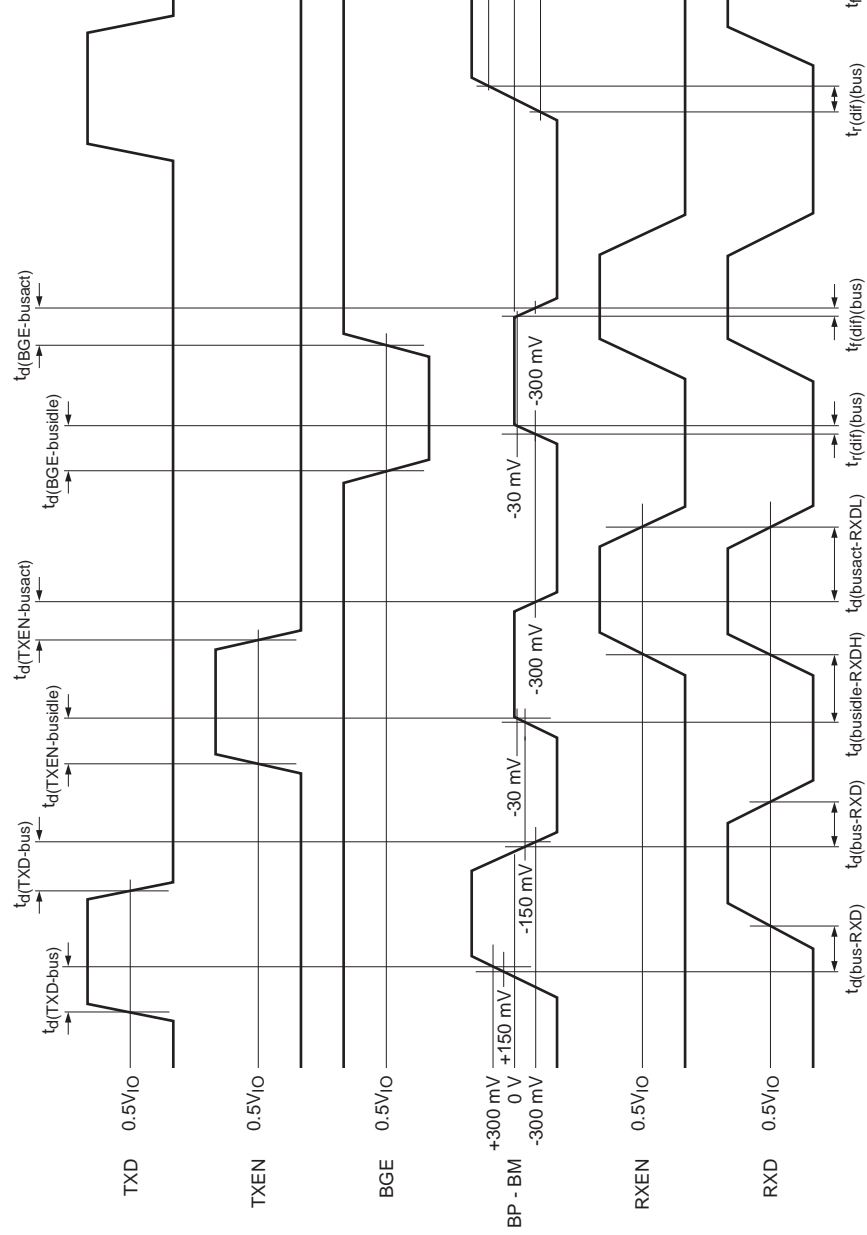
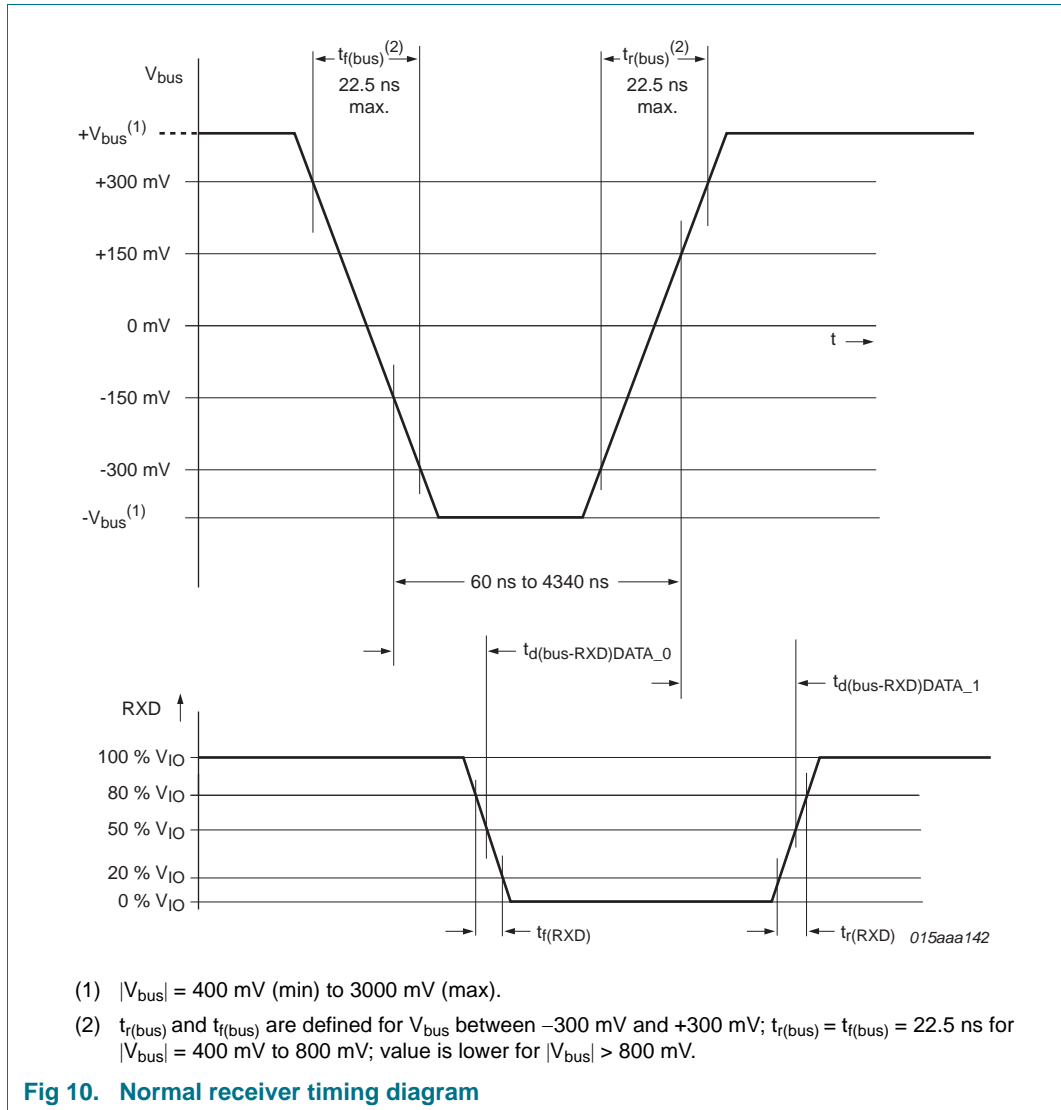

Fig 9. Detailed timing diagram



## 12. Application information

Further information on the application of the TJA1081G can be found in NXP application hints *AH102 TJA1081B/TJA1081G FlexRay node transceiver* ([Ref. 5](#)).

### 13. Test information

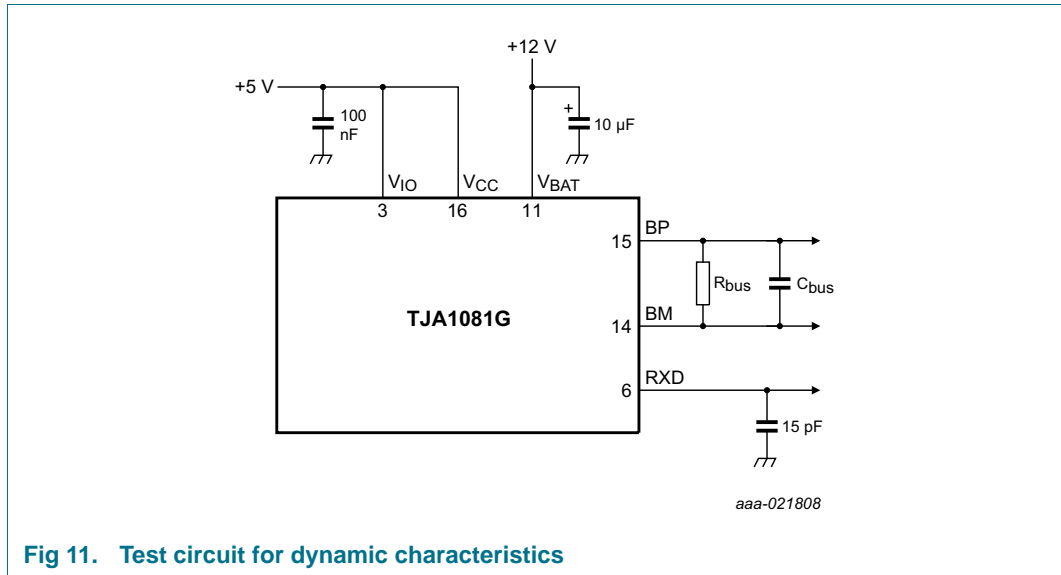

Fig 11. Test circuit for dynamic characteristics

#### 13.1 Quality information

This product has been qualified in accordance with the Automotive Electronics Council (AEC) standard Q100 Rev-G - *Failure mechanism based stress test qualification for integrated circuits*, and is suitable for use in automotive applications.

14. Package outline

SSOP16: plastic shrink small outline package; 16 leads; body width 5.3 mm

SOT338-1

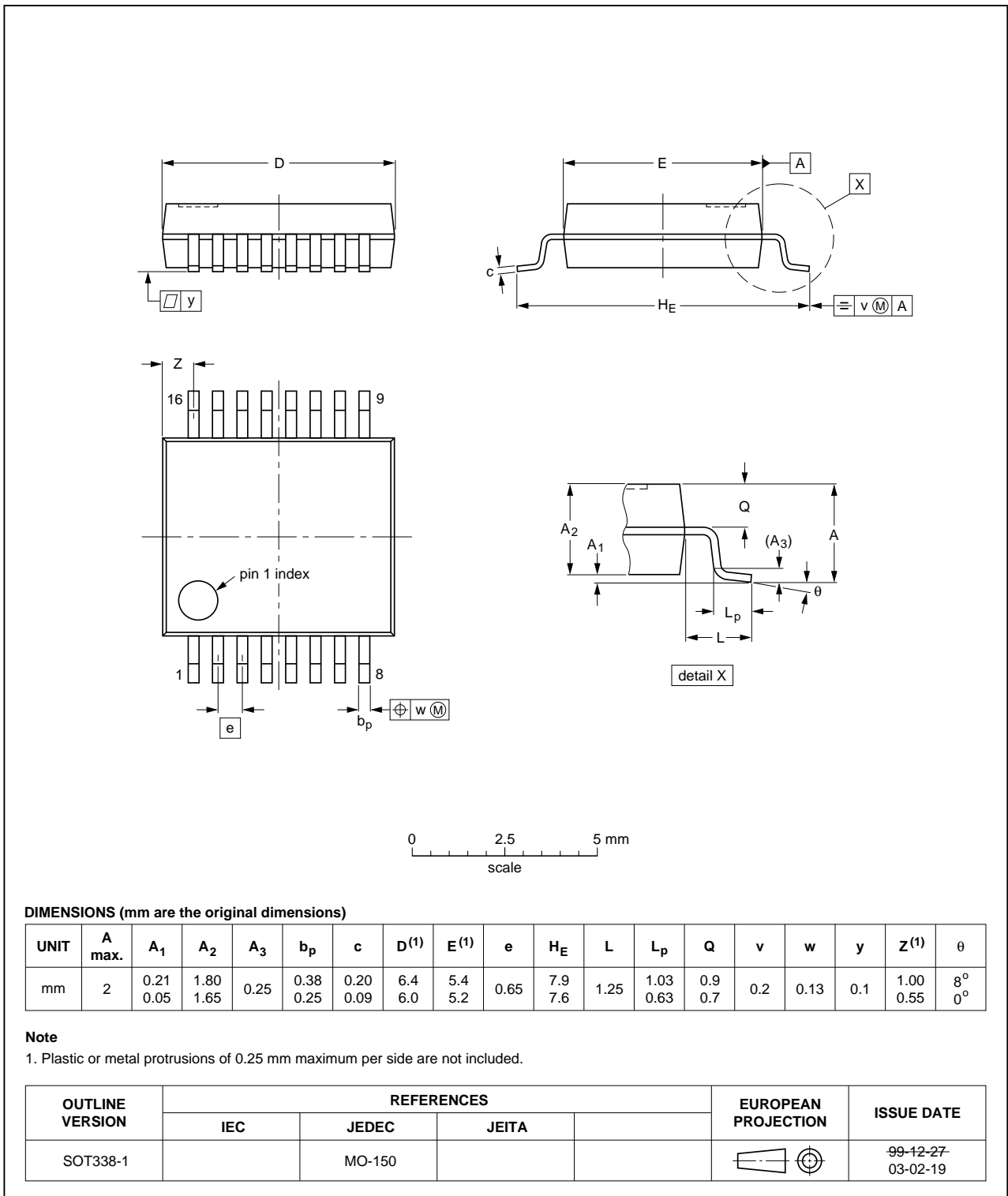

Fig 12. Package outline SOT338-1 (SSOP16)

## 15. Soldering of SMD packages

This text provides a very brief insight into a complex technology. A more in-depth account of soldering ICs can be found in Application Note *AN10365 "Surface mount reflow soldering description"*.

### 15.1 Introduction to soldering

Soldering is one of the most common methods through which packages are attached to Printed Circuit Boards (PCBs), to form electrical circuits. The soldered joint provides both the mechanical and the electrical connection. There is no single soldering method that is ideal for all IC packages. Wave soldering is often preferred when through-hole and Surface Mount Devices (SMDs) are mixed on one printed wiring board; however, it is not suitable for fine pitch SMDs. Reflow soldering is ideal for the small pitches and high densities that come with increased miniaturization.

### 15.2 Wave and reflow soldering

Wave soldering is a joining technology in which the joints are made by solder coming from a standing wave of liquid solder. The wave soldering process is suitable for the following:

- Through-hole components
- Leaded or leadless SMDs, which are glued to the surface of the printed circuit board

Not all SMDs can be wave soldered. Packages with solder balls, and some leadless packages which have solder lands underneath the body, cannot be wave soldered. Also, leaded SMDs with leads having a pitch smaller than ~0.6 mm cannot be wave soldered, due to an increased probability of bridging.

The reflow soldering process involves applying solder paste to a board, followed by component placement and exposure to a temperature profile. Leaded packages, packages with solder balls, and leadless packages are all reflow solderable.

Key characteristics in both wave and reflow soldering are:

- Board specifications, including the board finish, solder masks and vias
- Package footprints, including solder thieves and orientation
- The moisture sensitivity level of the packages
- Package placement
- Inspection and repair
- Lead-free soldering versus SnPb soldering

### 15.3 Wave soldering

Key characteristics in wave soldering are:

- Process issues, such as application of adhesive and flux, clinching of leads, board transport, the solder wave parameters, and the time during which components are exposed to the wave
- Solder bath specifications, including temperature and impurities

### 15.4 Reflow soldering

Key characteristics in reflow soldering are:

- Lead-free versus SnPb soldering; note that a lead-free reflow process usually leads to higher minimum peak temperatures (see [Figure 13](#)) than a SnPb process, thus reducing the process window
- Solder paste printing issues including smearing, release, and adjusting the process window for a mix of large and small components on one board
- Reflow temperature profile; this profile includes preheat, reflow (in which the board is heated to the peak temperature) and cooling down. It is imperative that the peak temperature is high enough for the solder to make reliable solder joints (a solder paste characteristic). In addition, the peak temperature must be low enough that the packages and/or boards are not damaged. The peak temperature of the package depends on package thickness and volume and is classified in accordance with [Table 16](#) and [17](#)

**Table 16. SnPb eutectic process (from J-STD-020D)**

Package thickness (mm)	Package reflow temperature (°C)	
	Volume (mm <sup>3</sup> )	
	< 350	≥ 350
< 2.5	235	220
≥ 2.5	220	220

**Table 17. Lead-free process (from J-STD-020D)**

Package thickness (mm)	Package reflow temperature (°C)		
	Volume (mm <sup>3</sup> )		
	< 350	350 to 2000	> 2000
< 1.6	260	260	260
1.6 to 2.5	260	250	245
> 2.5	250	245	245

Moisture sensitivity precautions, as indicated on the packing, must be respected at all times.

Studies have shown that small packages reach higher temperatures during reflow soldering, see [Figure 13](#).

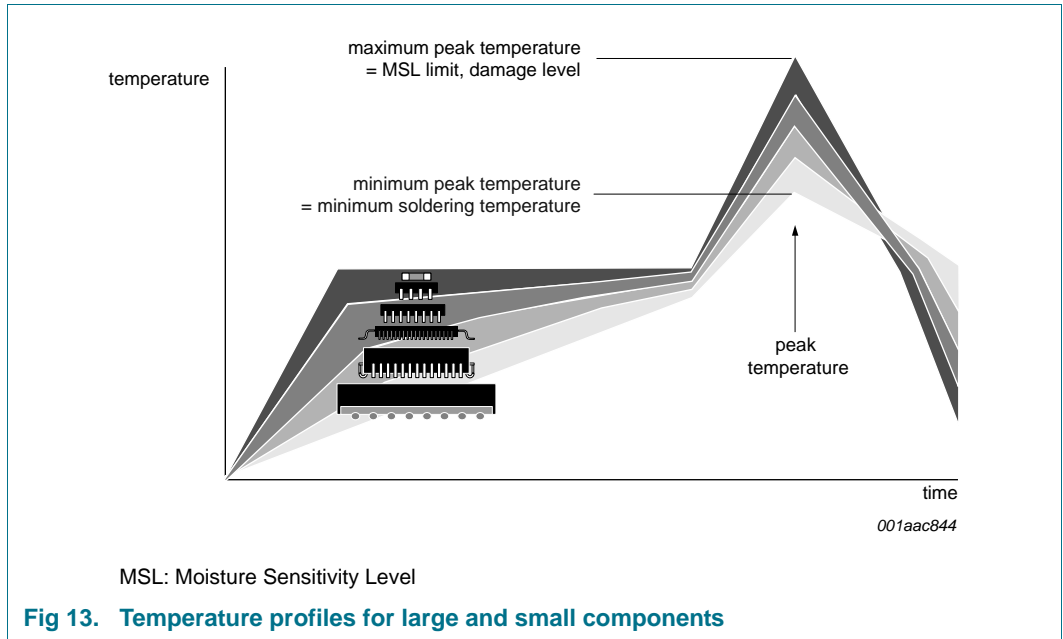

For further information on temperature profiles, refer to Application Note AN10365 “Surface mount reflow soldering description”.

## 16. Appendix: EPL 3.0.1 to TJA1081G parameter conversion

**Table 18. EPL 3.0.1 to TJA1081G conversion**

This table maps the EPL 3.0.1 parameters names to those in the TJA1081G. Values are provided for reference only (see the characteristics tables for comprehensive listings of guaranteed parameter values).

EPL 3.0.1				TJA1081G			
Symbol	Min	Max	Unit	Symbol	Min	Max	Unit
dBDRxAsym	-	5	ns	$\Delta t_{d(\text{bus-RXD})}$	-	5	ns
dBDRx10	-	75	ns	$t_{d(\text{bus-RXD})}$	-	75	ns
dBDRx01	-	75	ns	$t_{d(\text{bus-RXD})}$	-	75	ns
dBDRxai	50	275	ns	$t_{d(\text{busidle-RXDH})}$	100	275	ns
dBDRxia	100	325	ns	$t_{d(\text{busact-RXDL})}$	100	275	ns
dBDRxAsym	-	4	ns	$\Delta t_{d(\text{TXD-bus})}$	-	4	ns
dBDRx10	-	75	ns	$t_{d(\text{TXD-bus})}$	-	60	ns
dBDRx01	-	75	ns	$t_{d(\text{TXD-bus})}$	-	60	ns
dBDRxai	-	75	ns	$t_{d(\text{TXEN-busidle})}$	-	75	ns
dBDRxia	-	75	ns	$t_{d(\text{TXEN-busact})}$	-	75	ns
dBusTxai	-	30	ns	$t_{r(\text{dif})(\text{bus})(\text{DATA}_0\text{-idle})}$	-	30	ns
dBusTxia	-	30	ns	$t_{f(\text{dif})(\text{bus})(\text{idle-DATA}_0)}$	-	30	ns
dBusTx01	6	18.75	ns	$t_{r(\text{dif})(\text{bus})}$	6	18.75	ns
dBusTx10	6	18.75	ns	$t_{f(\text{dif})(\text{bus})}$	6	18.75	ns
uBDT <sub>xactive</sub>	600	2000	mV	$V_{OH(\text{dif})}$	600	2000	mV
uBDT <sub>xidle</sub>	0	30	mV	$V_{O(\text{idle})(\text{dif})}$	-25	+25	mV
uVDIG-OUT-HIGH	80	100	%	$V_{OH(\text{RXD})}$	$V_{IO} - 0.4$	$V_{IO}$	V
uVDIG-OUT-LOW	-	20	%	$V_{OL(\text{RXD})}$	-	0.4	V
uVDIG-IN-HIGH	-	70	%	$V_{IH(\text{TXEN})}$	$0.7V_{IO}$	5.5	V
				$V_{IH(\text{EN})}$	$0.7V_{IO}$	5.5	V
				$V_{IH(\text{STBN})}$	$0.7V_{IO}$	5.5	V
				$V_{IH(\text{BGE})}$	$0.7V_{IO}$	5.5	V
uVDIG-IN-LOW	30	-	%	$V_{IL(\text{TXEN})}$	-0.3	$0.3V_{IO}$	V
				$V_{IL(\text{EN})}$	-0.3	$0.3V_{IO}$	V
				$V_{IL(\text{STBN})}$	-0.3	$0.3V_{IO}$	V
				$V_{IL(\text{BGE})}$	-0.3	$0.3V_{IO}$	V
uData0	-300	-150	mV	$V_{IL(\text{dif})}$	-300	-150	mV
uData1	150	300	mV	$V_{IH(\text{dif})}$	150	300	mV
uData1- uData0	-30	+30	mV	$\Delta V_{i(\text{dif})(\text{H-L})}$	-30	+30	mV
dBDAActivityDetection	100	250	ns	$t_{\text{det}(\text{act})(\text{bus})}$	100	200	ns
dBDDIdleDetection	50	200	ns	$t_{\text{det}(\text{idle})(\text{bus})}$	50	200	ns
R <sub>CM1</sub> , R <sub>CM2</sub>	10	40	k $\Omega$	$R_{i(\text{BP})}$ , $R_{i(\text{BM})}$	10	40	k $\Omega$
uCM	-10	+15	V	$V_{\text{cm}}$ <sup>[1]</sup>	-10	+15	V
iBM <sub>GNDShortMax</sub>	-	60	mA	$ I_{O(\text{sc})(\text{BM})} $	-	60	mA
iBP <sub>GNDShortMax</sub>	-	60	mA	$ I_{O(\text{sc})(\text{BP})} $	-	60	mA
iBM <sub>BAT48ShortMax</sub>	-	72	mA	$ I_{O(\text{sc})(\text{BM})} $	-	60	mA

**Table 18. EPL 3.0.1 to TJA1081G conversion ...continued**

This table maps the EPL 3.0.1 parameters names to those in the TJA1081G. Values are provided for reference only (see the characteristics tables for comprehensive listings of guaranteed parameter values).

EPL 3.0.1				TJA1081G			
Symbol	Min	Max	Unit	Symbol	Min	Max	Unit
iBP <sub>BAT48ShortMax</sub>	-	72	mA	I <sub>O(sc)</sub> (BP)	-	60	mA
iBM <sub>BAT27ShortMax</sub>	-	60	mA	I <sub>O(sc)</sub> (BM)	-	60	mA
iBP <sub>BAT27ShortMax</sub>	-	60	mA	I <sub>O(sc)</sub> (BP)	-	60	mA
uBias - Non-Low-Power	1800	3200	mV	V <sub>o(idle)</sub> (BP), V <sub>o(idle)</sub> (BM) <sup>[2]</sup>	1800	3150	mV
uBias - Low-Power	-200	+200	mV	V <sub>o(idle)</sub> (BP), V <sub>o(idle)</sub> (BM) <sup>[3]</sup>	-0.1	+0.1	V
dBDWakePulseFilter	1	500	μs	t <sub>fttr</sub> (WAKE)	2.9	100	μs
dWU <sub>0Detect</sub>	1	4	μs	t <sub>det</sub> (wake)DATA_0	1	4	μs
dWU <sub>IdleDetect</sub>	1	4	μs	t <sub>det</sub> (wake)idle	1	4	μs
dWU <sub>Timeout</sub>	48	140	μs	t <sub>det</sub> (wake)tot	50	115	μs
uV <sub>BAT-WAKE</sub> (V <sub>CC</sub> implemented)	-	7	V	V <sub>BAT</sub>	4.75	60	V
uBDUVV <sub>BAT</sub>	4	5.5	V	V <sub>uvd</sub> (VBAT)	4.45	4.715	V
uBDUVV <sub>VCC</sub>	4	-	V	V <sub>uvd</sub> (VCC)	4.45	4.72	V
dBDUVV <sub>VCC</sub>	-	1000	ms	t <sub>det</sub> (uv)(VCC)	5	100	μs
				t <sub>to</sub> (uvd)(VCC)	100	670	ms
iBP <sub>Leak</sub>	-	25	μA	I <sub>LI</sub> (BP)	-5	+5	μA
iBM <sub>Leak</sub>	-	25	μA	I <sub>LI</sub> (BM)	-5	+5	μA
Functional class: BD voltage regulator control				implemented; see <a href="#">Section 2.5</a>			
Functional class: Bus Driver logic level adaptation				implemented; see <a href="#">Section 2.5</a>			
Functional class: Bus Driver - Bus guardian interface				implemented; see <a href="#">Section 2.5</a>			
Device qualification according to AEC-Q100 (Rev. F)				see <a href="#">Section 2.1</a>			
T <sub>AMB_Class1</sub>	-40	+125	°C	T <sub>amb</sub>	-40	+125	°C
dBDTxD <sub>M</sub>	-50	+50	ns	Δt <sub>d</sub> (TXEN-bus)	-50	+50	μs
iBM <sub>-5VshortMax</sub>	-	60	mA	I <sub>O(sc)</sub> (BM)	-	60	mA
iBP <sub>-5VshortMax</sub>	-	60	mA	I <sub>O(sc)</sub> (BP)	-	60	mA
iBM <sub>BPSshortMax</sub>	-	60	mA	I <sub>O(sc)</sub> (BP-BM)	-	60	mA
iBP <sub>BMSshortMax</sub>	-	60	mA	I <sub>O(sc)</sub> (BM-BP)	-	60	mA
iBM <sub>BAT60ShortMax</sub>	-	90	mA	I <sub>O(sc)</sub> (BM)	-	60	mA
iBP <sub>BAT60ShortMax</sub>	-	90	mA	I <sub>O(sc)</sub> (BP)	-	60	mA
dBDUVV <sub>BAT</sub>	-	1000	ms	t <sub>det</sub> (uv)(VBAT)	5	100	μs
uUV <sub>IO</sub>	2	-	V	V <sub>uvd</sub> (VIO)	2.55	2.765	V
dBDUVV <sub>IO</sub>	-	1000	ms	t <sub>det</sub> (uv)(VIO)	5	100	μs
				t <sub>to</sub> (uvd)(VIO)	100	670	ms
dBDWakeupReaction <sub>local</sub>	-	100	μs	t <sub>d</sub> (wakedet-INHH)	-	35	μs
				t <sub>d</sub> (event-ERRNL)	-	10	μs
				t <sub>d</sub> (wakedet-RXDL)	-	10	μs
dBDWakeupReaction <sub>remote</sub>	-	100	μs	t <sub>d</sub> (wakedet-INHH)	-	35	μs
				t <sub>d</sub> (event-ERRNL)	-	10	μs
				t <sub>d</sub> (wakedet-RXDL)	-	10	μs

**Table 18. EPL 3.0.1 to TJA1081G conversion ...continued**

This table maps the EPL 3.0.1 parameters names to those in the TJA1081G. Values are provided for reference only (see the characteristics tables for comprehensive listings of guaranteed parameter values).

EPL 3.0.1				TJA1081G						
Symbol	Min	Max	Unit	Symbol	Min	Max	Unit			
dBDTxActiveMax	650	2600	μs	t <sub>detCL</sub> (TXEN)	650	2600	μs			
dBDModeChange	-	100	μs	t <sub>d</sub> (STBNX-moch)	-	100	μs			
				t <sub>d</sub> (ENX-moch)				-	100	μs
dReactionTime <sub>ERRN</sub>	-	100	μs	t <sub>d</sub> (event-ERRNL)	-	10	μs			
uINH1 <sub>Not_Sleep</sub>	uVBAT - 1 V	-	V	V <sub>OH</sub> (INH)	V <sub>BAT</sub> - 0.8	V <sub>BAT</sub>	V			
iINH1 <sub>Leak</sub>	-	10	μA	I <sub>L</sub> (INH)	-5	+5	μA			
uData0_LP	-400	-100	mV	V <sub>IL</sub> (dif) (pins BP and BM)	-400	-100	mV			
dWU <sub>Interrupt</sub>	0.13	1	μs	t <sub>sup</sub> (int)wake	130	1000	ns			
uBDLogic_1	-	60	%	V <sub>IH</sub> (TXD)	0.6V <sub>IO</sub>	V <sub>IO</sub> + 0.3 V	V			
uBDLogic_0	40	-	%	V <sub>IL</sub> (TXD)	-0.3	0.4V <sub>IO</sub>	V			
dBDRV <sub>CC</sub>	-	10	ms	t <sub>rec</sub> (uv)(VCC)	5	100	μs			
				t <sub>to</sub> (uvr)(VCC)				1	5.2	ms
dBDRV <sub>BAT</sub>	-	10	ms	t <sub>rec</sub> (uv)(VBAT)	5	100	μs			
				t <sub>to</sub> (uvr)(VBAT)				1	5.2	ms
dBDRV <sub>IO</sub>	-	10	ms	t <sub>rec</sub> (uv)(VIO)	5	100	μs			
				t <sub>to</sub> (uvr)(VIO)				1	5.2	ms
iBP <sub>LeakGND</sub>	-	1600	μA	I <sub>LI</sub> (BP)	-1600	+1600	μA			
iBM <sub>LeakGND</sub>	-	1600	μA	I <sub>LI</sub> (BM)	-1600	+1600	μA			
Functional class: Bus Driver Remote Wakeup				implemented; see <a href="#">Section 2.5</a>						
Functional class: Increased Voltage Amplitude Transmitter				implemented; see <a href="#">Section 2.5</a>						
uESD <sub>EXT</sub>	6	-	kV	V <sub>ESD</sub>  : HBM on pins BP and BM to GND	6	-	kV			
				V <sub>ESD</sub>  : HBM on pins V <sub>BAT</sub> and WAKE to GND				4	-	kV
uESD <sub>INT</sub>	2	-	kV	V <sub>ESD</sub>   (HBM on any other pin)	2	-	kV			
uESD	6	-	kV	IEC 61000-4-2 on pins BP, BM, V <sub>BAT</sub> and WAKE	6	-	kV			
dBDRxD <sub>R15</sub> + dBDRxD <sub>F15</sub>	-	13	ns	t <sub>(r+f)</sub> (pin RXD; 15 pF load)	-	13	ns			
dBDRxD <sub>R15</sub> - dBDRxD <sub>F15</sub>	-	5	ns	Δt <sub>(r-f)</sub>   (pin RXD)	-	5	ns			
C <sub>BDTxD</sub>	-	10	pF	C <sub>I</sub> (pin TXD)	-	10	pF			
dBDTxRxai	-	325	ns	t <sub>d</sub> (TXENH-RXDH)	-	325	ns			
uVDIG-OUT-UV	-	500	mV	V <sub>O</sub> (ERRN); with V <sub>IO</sub> < V <sub>uvd</sub> (VIO)	-	500	mV			
				V <sub>O</sub> (RXD); with V <sub>IO</sub> < V <sub>uvd</sub> (VIO)				-	500	mV
				V <sub>O</sub> (RXEN); with V <sub>IO</sub> < V <sub>uvd</sub> (VIO)				-	500	mV
valid operating modes when V <sub>BAT</sub> ≥ 5.5 V; V <sub>CC</sub> = nominal (if implemented)				Normal, Receive only, Standby, Sleep						
valid operating modes when V <sub>BAT</sub> ≥ 7 V; V <sub>CC</sub> = nominal				Normal, Receive only, Standby, Sleep						

**Table 18. EPL 3.0.1 to TJA1081G conversion ...continued**

This table maps the EPL 3.0.1 parameters names to those in the TJA1081G. Values are provided for reference only (see the characteristics tables for comprehensive listings of guaranteed parameter values).

EPL 3.0.1				TJA1081G			
Symbol	Min	Max	Unit	Symbol	Min	Max	Unit
uV <sub>DIG-OUT-OFF</sub>	product specific			V <sub>O(ERRN)</sub> <sup>[4]</sup>	-	0.5	V
				V <sub>O(RXD)</sub> <sup>[4]</sup>	V <sub>IO</sub> - 0.5	V <sub>IO</sub>	V
				V <sub>O(RXEN)</sub> <sup>[4]</sup>	V <sub>IO</sub> - 0.5	V <sub>IO</sub>	V
R <sub>BDTransmitter</sub>	product-specific			Z <sub>o(eq)TX</sub>	35	100	Ω
RxD signal sum of rise and fall time at TP4_CC	-	16.5	ns	t <sub>(r+f)(RXD)</sub> (10 pF load on 50 Ω μstrip; simulated)	-	16.5	ns
uV <sub>BAT-WAKE</sub> (no V <sub>CC</sub> )	-	5.5	V	V <sub>BAT</sub> (operating range)	4.75	60	V
dBDRxD <sub>R25</sub> + dBDRxD <sub>F25</sub>	-	16.5	ns	t <sub>(r+f)(RXD)</sub> (25 pF load)	-	16.5	ns
dBDRxD <sub>R25</sub> - dBDRxD <sub>F25</sub>	-	5	ns	Δt <sub>(r-f)(RXD)</sub>	-5	+5	ns
dBusTxDif	-	3	ns	Δt <sub>(r-f)(dif)</sub> (on bus)	-3	+3	ns
RxD signal difference of rise and fall time at TP4_CC	-	5	ns	Δt <sub>(r-f)(RXD)</sub>   (10 pF load on 50 Ω μstrip; simulated)	-	5	ns

- [1] V<sub>cm</sub> is the BP/BM common mode voltage (V<sub>BP</sub> + V<sub>BM</sub>/2) and is specified in conditions column for V<sub>IH(dif)</sub> and V<sub>IH(dif)</sub> for pins BP and BM; see Table 14. V<sub>cm</sub> is tested on a receiving bus driver with a transmitting bus driver that has a ground offset voltage in the range -12.5 V to +12.5 V and that transmits a 50/50 pattern.
- [2] Min: V<sub>o(idle)(BP)</sub> = V<sub>o(idle)(BM)</sub> = 0.4V<sub>CC</sub> = 0.4 × 4.5 V = 1800 mV; max value: V<sub>o(idle)(BP)</sub> = V<sub>o(idle)(BM)</sub> = 0.6V<sub>CC</sub> = 0.6 × 5.25 V = 3150 mV; the nominal voltage is 2500 mV.
- [3] The nominal voltage is 0 mV.
- [4] Power off.

## 17. Abbreviations

Table 19. Abbreviations

Abbreviation	Description
BSS	Byte Start Sequence
CDM	Charged Device Model
ECU	Electronic Control Unit
EMC	ElectroMagnetic Compatibility
EME	ElectroMagnetic Emission
EMI	ElectroMagnetic Immunity
ESD	ElectroStatic Discharge
HBM	Human Body Model
MM	Machine Model
TSS	Transmission Start Sequence

## 18. References

- [1] **EPL** — FlexRay Communications System Electrical Physical Layer Specification Version 3.0.1, FlexRay Consortium
- [2] **ISO 17458-4:2013** — Road vehicles - FlexRay Communications System part 4: Electrical physical layer specification
- [3] **TJA1080A** — FlexRay transceiver data sheet, [www.nxp.com](http://www.nxp.com)
- [4] **TJA1081B** — FlexRay transceiver data sheet, [www.nxp.com](http://www.nxp.com)
- [5] **AH1102** — TJA1081B/TJA1081G FlexRay node transceiver application hints, available from NXP Semiconductors

## 19. Revision history

Table 20. Revision history

Document ID	Release date	Data sheet status	Change notice	Supersedes
TJA1081G v.1	20161028	Product data sheet	-	-

## 20. Legal information

### 20.1 Data sheet status

Document status <sup>[1][2]</sup>	Product status <sup>[3]</sup>	Definition
Objective [short] data sheet	Development	This document contains data from the objective specification for product development.
Preliminary [short] data sheet	Qualification	This document contains data from the preliminary specification.
Product [short] data sheet	Production	This document contains the product specification.

[1] Please consult the most recently issued document before initiating or completing a design.

[2] The term 'short data sheet' is explained in section "Definitions".

[3] The product status of device(s) described in this document may have changed since this document was published and may differ in case of multiple devices. The latest product status information is available on the Internet at URL <http://www.nxp.com>.

### 20.2 Definitions

**Draft** — The document is a draft version only. The content is still under internal review and subject to formal approval, which may result in modifications or additions. NXP Semiconductors does not give any representations or warranties as to the accuracy or completeness of information included herein and shall have no liability for the consequences of use of such information.

**Short data sheet** — A short data sheet is an extract from a full data sheet with the same product type number(s) and title. A short data sheet is intended for quick reference only and should not be relied upon to contain detailed and full information. For detailed and full information see the relevant full data sheet, which is available on request via the local NXP Semiconductors sales office. In case of any inconsistency or conflict with the short data sheet, the full data sheet shall prevail.

**Product specification** — The information and data provided in a Product data sheet shall define the specification of the product as agreed between NXP Semiconductors and its customer, unless NXP Semiconductors and customer have explicitly agreed otherwise in writing. In no event however, shall an agreement be valid in which the NXP Semiconductors product is deemed to offer functions and qualities beyond those described in the Product data sheet.

### 20.3 Disclaimers

**Limited warranty and liability** — Information in this document is believed to be accurate and reliable. However, NXP Semiconductors does not give any representations or warranties, expressed or implied, as to the accuracy or completeness of such information and shall have no liability for the consequences of use of such information. NXP Semiconductors takes no responsibility for the content in this document if provided by an information source outside of NXP Semiconductors.

In no event shall NXP Semiconductors be liable for any indirect, incidental, punitive, special or consequential damages (including - without limitation - lost profits, lost savings, business interruption, costs related to the removal or replacement of any products or rework charges) whether or not such damages are based on tort (including negligence), warranty, breach of contract or any other legal theory.

Notwithstanding any damages that customer might incur for any reason whatsoever, NXP Semiconductors' aggregate and cumulative liability towards customer for the products described herein shall be limited in accordance with the *Terms and conditions of commercial sale* of NXP Semiconductors.

**Right to make changes** — NXP Semiconductors reserves the right to make changes to information published in this document, including without limitation specifications and product descriptions, at any time and without notice. This document supersedes and replaces all information supplied prior to the publication hereof.

**Suitability for use in automotive applications** — This NXP Semiconductors product has been qualified for use in automotive applications. Unless otherwise agreed in writing, the product is not designed, authorized or warranted to be suitable for use in life support, life-critical or safety-critical systems or equipment, nor in applications where failure or malfunction of an NXP Semiconductors product can reasonably be expected to result in personal injury, death or severe property or environmental damage. NXP Semiconductors accepts no liability for inclusion and/or use of NXP Semiconductors products in such equipment or applications and therefore such inclusion and/or use is at the customer's own risk.

**Applications** — Applications that are described herein for any of these products are for illustrative purposes only. NXP Semiconductors makes no representation or warranty that such applications will be suitable for the specified use without further testing or modification.

Customers are responsible for the design and operation of their applications and products using NXP Semiconductors products, and NXP Semiconductors accepts no liability for any assistance with applications or customer product design. It is customer's sole responsibility to determine whether the NXP Semiconductors product is suitable and fit for the customer's applications and products planned, as well as for the planned application and use of customer's third party customer(s). Customers should provide appropriate design and operating safeguards to minimize the risks associated with their applications and products.

NXP Semiconductors does not accept any liability related to any default, damage, costs or problem which is based on any weakness or default in the customer's applications or products, or the application or use by customer's third party customer(s). Customer is responsible for doing all necessary testing for the customer's applications and products using NXP Semiconductors products in order to avoid a default of the applications and the products or of the application or use by customer's third party customer(s). NXP does not accept any liability in this respect.

**Limiting values** — Stress above one or more limiting values (as defined in the Absolute Maximum Ratings System of IEC 60134) will cause permanent damage to the device. Limiting values are stress ratings only and (proper) operation of the device at these or any other conditions above those given in the Recommended operating conditions section (if present) or the Characteristics sections of this document is not warranted. Constant or repeated exposure to limiting values will permanently and irreversibly affect the quality and reliability of the device.

**Terms and conditions of commercial sale** — NXP Semiconductors products are sold subject to the general terms and conditions of commercial sale, as published at <http://www.nxp.com/profile/terms>, unless otherwise agreed in a valid written individual agreement. In case an individual agreement is concluded only the terms and conditions of the respective agreement shall apply. NXP Semiconductors hereby expressly objects to applying the customer's general terms and conditions with regard to the purchase of NXP Semiconductors products by customer.

**No offer to sell or license** — Nothing in this document may be interpreted or construed as an offer to sell products that is open for acceptance or the grant, conveyance or implication of any license under any copyrights, patents or other industrial or intellectual property rights.

**Export control** — This document as well as the item(s) described herein may be subject to export control regulations. Export might require a prior authorization from competent authorities.

**Quick reference data** — The Quick reference data is an extract of the product data given in the Limiting values and Characteristics sections of this document, and as such is not complete, exhaustive or legally binding.

**Translations** — A non-English (translated) version of a document is for reference only. The English version shall prevail in case of any discrepancy between the translated and English versions.

## 20.4 Licenses

### NXP ICs with FlexRay functionality

This NXP product contains functionality that is compliant with the FlexRay specifications.

These specifications and the material contained in them, as released by the FlexRay Consortium, are for the purpose of information only. The FlexRay Consortium and the companies that have contributed to the specifications shall not be liable for any use of the specifications.

The material contained in these specifications is protected by copyright and other types of Intellectual Property Rights. The commercial exploitation of the material contained in the specifications requires a license to such Intellectual Property Rights.

These specifications may be utilized or reproduced without any modification, in any form or by any means, for informational purposes only. For any other purpose, no part of the specifications may be utilized or reproduced, in any form or by any means, without permission in writing from the publisher.

The FlexRay specifications have been developed for automotive applications only. They have neither been developed nor tested for non-automotive applications.

The word FlexRay and the FlexRay logo are registered trademarks.

## 20.5 Trademarks

Notice: All referenced brands, product names, service names and trademarks are the property of their respective owners.

## 21. Contact information

For more information, please visit: <http://www.nxp.com>

For sales office addresses, please send an email to: [salesaddresses@nxp.com](mailto:salesaddresses@nxp.com)

## 22. Contents

<b>1</b>	<b>General description</b> . . . . .	<b>1</b>	7.4.10	UV <sub>VCC</sub> flag . . . . .	18
<b>2</b>	<b>Features and benefits</b> . . . . .	<b>1</b>	7.4.11	UV <sub>VIO</sub> flag . . . . .	19
2.1	Optimized for time triggered communication systems . . . . .	1	7.5	Status register . . . . .	19
2.2	Low-power management . . . . .	1	<b>8</b>	<b>Limiting values</b> . . . . .	<b>21</b>
2.3	Diagnosis (detection and signaling) . . . . .	2	<b>9</b>	<b>Thermal characteristics</b> . . . . .	<b>22</b>
2.4	Protection . . . . .	2	<b>10</b>	<b>Static characteristics</b> . . . . .	<b>22</b>
2.5	Functional classes according to FlexRay electrical physical layer specification (see <a href="#">Ref. 2</a> ) . . . . .	2	<b>11</b>	<b>Dynamic characteristics</b> . . . . .	<b>28</b>
<b>3</b>	<b>Quick reference data</b> . . . . .	<b>3</b>	<b>12</b>	<b>Application information</b> . . . . .	<b>33</b>
<b>4</b>	<b>Ordering information</b> . . . . .	<b>3</b>	<b>13</b>	<b>Test information</b> . . . . .	<b>34</b>
<b>5</b>	<b>Block diagram</b> . . . . .	<b>4</b>	13.1	Quality information . . . . .	34
<b>6</b>	<b>Pinning information</b> . . . . .	<b>5</b>	<b>14</b>	<b>Package outline</b> . . . . .	<b>35</b>
6.1	Pinning . . . . .	5	<b>15</b>	<b>Soldering of SMD packages</b> . . . . .	<b>36</b>
6.2	Pin description . . . . .	5	15.1	Introduction to soldering . . . . .	36
<b>7</b>	<b>Functional description</b> . . . . .	<b>6</b>	15.2	Wave and reflow soldering . . . . .	36
7.1	Operating modes . . . . .	6	15.3	Wave soldering . . . . .	36
7.1.1	Bus activity and idle detection . . . . .	6	15.4	Reflow soldering . . . . .	37
7.1.2	Signaling on pin ERRN . . . . .	7	<b>16</b>	<b>Appendix: EPL 3.0.1 to TJA1081G parameter conversion</b> . . . . .	<b>39</b>
7.1.3	Signaling on pins RXEN and RXD . . . . .	8	<b>17</b>	<b>Abbreviations</b> . . . . .	<b>43</b>
7.1.4	Operating mode transitions . . . . .	9	<b>18</b>	<b>References</b> . . . . .	<b>43</b>
7.1.5	Normal mode . . . . .	14	<b>19</b>	<b>Revision history</b> . . . . .	<b>43</b>
7.1.6	Receive-only mode . . . . .	14	<b>20</b>	<b>Legal information</b> . . . . .	<b>44</b>
7.1.7	Standby mode . . . . .	14	20.1	Data sheet status . . . . .	44
7.1.8	Go-to-sleep mode . . . . .	14	20.2	Definitions . . . . .	44
7.1.9	Sleep mode . . . . .	14	20.3	Disclaimers . . . . .	44
7.2	Wake-up mechanism . . . . .	15	20.4	Licenses . . . . .	45
7.2.1	Remote wake-up . . . . .	15	20.5	Trademarks . . . . .	45
7.2.1.1	Bus wake-up via wake-up pattern . . . . .	15	<b>21</b>	<b>Contact information</b> . . . . .	<b>45</b>
7.2.1.2	Bus wake-up via dedicated FlexRay data frame . . . . .	15	<b>22</b>	<b>Contents</b> . . . . .	<b>46</b>
7.2.2	Local wake-up via pin WAKE . . . . .	16			
7.3	Fail-silent behavior . . . . .	17			
7.3.1	V <sub>BAT</sub> undervoltage . . . . .	17			
7.3.2	V <sub>CC</sub> undervoltage . . . . .	17			
7.3.3	V <sub>IO</sub> undervoltage . . . . .	17			
7.4	Flags . . . . .	17			
7.4.1	Local wake-up source flag . . . . .	17			
7.4.2	Remote wake-up source flag . . . . .	17			
7.4.3	Wake flag . . . . .	18			
7.4.4	Power-on flag . . . . .	18			
7.4.5	Temperature medium flag . . . . .	18			
7.4.6	Temperature high flag . . . . .	18			
7.4.7	TXEN clamped flag . . . . .	18			
7.4.8	Bus error flag . . . . .	18			
7.4.9	UV <sub>VBAT</sub> flag . . . . .	18			

Please be aware that important notices concerning this document and the product(s) described herein, have been included in section 'Legal information'.

© NXP Semiconductors N.V. 2016.

All rights reserved.

For more information, please visit: <http://www.nxp.com>

For sales office addresses, please send an email to: [salesaddresses@nxp.com](mailto:salesaddresses@nxp.com)

Date of release: 28 October 2016

Document identifier: TJA1081G

## Looking for pricing, stock, or lifecycle information?

Click below to explore more details on WIN SOURCE:

- ⊖ [View TJA1081GTS/0Z on WIN SOURCE](#)
- ⊖ [NXP / Nexperia Information](#)

## Optimize Your Supply Chain with WIN SOURCE Solutions

- ✓ Global Sourcing Solution
- ✓ Obsolete Management
- ✓ Cost Control Management
- ✓ Shortage Management
- ✓ Alternative Solution
- ✓ Excess Inventory Management