



**THE DATASHEET OF
THS4151IDGK**



HIGH-SPEED DIFFERENTIAL I/O AMPLIFIERS

FEATURES

- **High Performance**
 - 150 MHz –3 dB Bandwidth ($V_{CC} = \pm 5\text{ V}$)
 - 650 V/ μs Slew Rate ($V_{CC} = \pm 15\text{ V}$)
 - –89 dB Third Harmonic Distortion at 1 MHz
 - –83 dB Total Harmonic Distortion at 1 MHz
 - 7.6 nV/ $\sqrt{\text{Hz}}$ Input-Referred Noise
- **Differential Input/Differential Output**
 - Balanced Outputs Reject Common-Mode Noise
 - Differential Reduced Second Harmonic Distortion
- **Wide Power-Supply Range**
 - $V_{CC} = 5\text{ V}$ Single-Supply to $\pm 15\text{ V}$ Dual Supply
- $I_{CC(SD)} = 1\text{ mA}$ ($V_{CC} = \pm 5$) in Shutdown Mode (THS4150)

KEY APPLICATIONS

- Single-Ended to Differential Conversion
- Differential ADC Driver
- Differential Antialiasing
- Differential Transmitter and Receiver
- Output Level Shifter

DESCRIPTION

The THS415x is one in a family of fully differential input/differential output devices fabricated using Texas Instruments' state-of-the-art BiComl complementary bipolar process.

The THS415x is made of a true fully-differential signal path from input to output. This design leads to an excellent common-mode noise rejection and improved total harmonic distortion.

RELATED DEVICES

DEVICE	DESCRIPTION
THS412x	100 MHz, 43 V/ μs , 3.7 nV/ $\sqrt{\text{Hz}}$
THS413x	150 MHz, 51 V/ μs , 1.3 nV/ $\sqrt{\text{Hz}}$
THS414x	160 MHz, 450 V/ μs , 6.5 nV/ $\sqrt{\text{Hz}}$

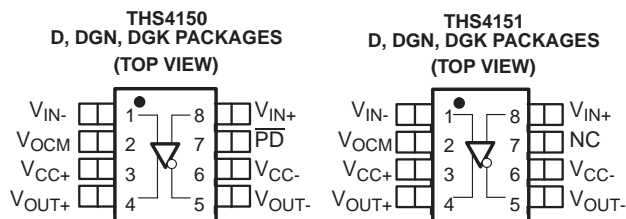

HIGH-SPEED DIFFERENTIAL I/O FAMILY

DEVICE	NUMBER OF CHANNELS	SHUTDOWN
THS4150	1	X
THS4151	1	-

Typical A/D Application Circuit

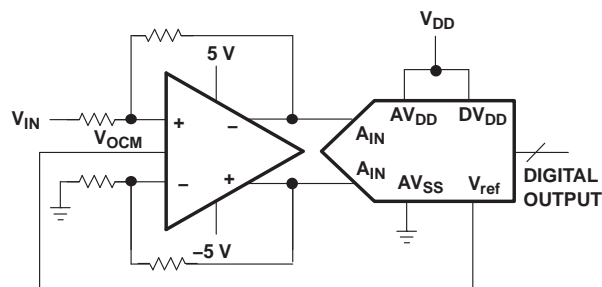

THS4151
TOTAL HARMONIC DISTORTION
vs
FREQUENCY

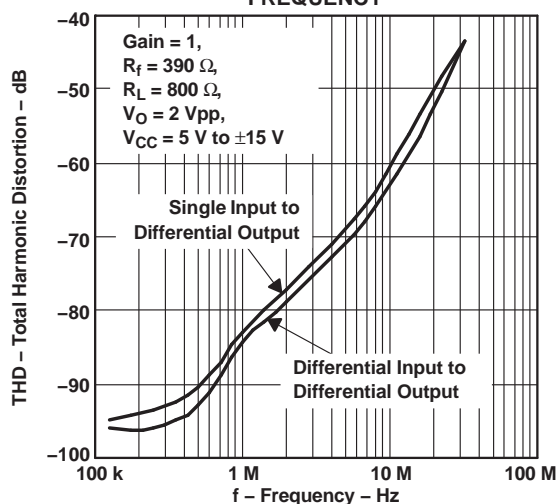

Please be aware that an important notice concerning availability, standard warranty, and use in critical applications of Texas Instruments semiconductor products and disclaimers thereto appears at the end of this data sheet.

PowerPAD is a trademark of Texas Instruments.
All other trademarks are the property of their respective owners.



These devices have limited built-in ESD protection. The leads should be shorted together or the device placed in conductive foam during storage or handling to prevent electrostatic damage to the MOS gates.

AVAILABLE OPTIONS⁽¹⁾

T _A	PACKAGED DEVICES					EVALUATION MODULES
	SMALL OUTLINE(D)	MSOP PowerPAD™		MSOP		
		(DGN)	SYMBOL	(DGK)	SYMBOL	
0°C to 70°C	THS4150CD	THS4150CDGN	AQB	THS4150CDGK	ATT	THS4150EVM
	THS4151CD	THS4151CDGN	AQD	THS4151CDGK	ATU	THS4151EVM
–40°C to 85°C	THS4150ID	THS4150IDGN	AQC	THS4150IDGK	AST	–
	THS4151ID	THS4151IDGN	AQE	THS4151IDGK	ASU	–

(1) For the most current package and ordering information, see the Package Option Addendum at the end of this document, or see the TI web site at www.ti.com.

ABSOLUTE MAXIMUM RATINGS⁽¹⁾

Over operating free-air temperature range (unless otherwise noted).

		UNIT	
V _{CC-} to V _{CC+}	Supply voltage	±16.5 V	
V _I	Input voltage	±V _{CC}	
I _O	Output current ⁽²⁾	150 mA	
V _{ID}	Differential input voltage	±6 V	
Continuous total power dissipation		See Dissipation Rating Table	
T _J	Maximum junction temperature ⁽³⁾	150°C	
	Maximum junction temperature, continuous operation, long term reliability ⁽⁴⁾	125°C	
T _A	Operating free-air temperature	C suffix	0°C to 70°C
		I suffix	–40°C to 85°C
T _{stg}	Storage temperature	–65°C to 150°C	
	Lead temperature ⁽⁵⁾		
ESD ratings	HBM	2500 V	
	CDM	1500 V	
	MM	200 V	

- (1) Stresses beyond those listed under absolute maximum ratings may cause permanent damage to the device. These are stress ratings only, and functional operation of the device at these or any other conditions beyond those indicated under recommended operating conditions is not implied. Exposure to absolute-maximum-rated conditions for extended periods may affect device reliability.
- (2) The THS415x may incorporate a PowerPad™ on the underside of the chip. This acts as a heatsink and must be connected to a thermally dissipative plane for proper power dissipation. Failure to do so may result in exceeding the maximum junction temperature which could permanently damage the device. See TI technical briefs [SLMA002](#) and [SLMA004](#) for more information about utilizing the PowerPad™ thermally enhanced package.
- (3) The absolute maximum temperature under any condition is limited by the constraints of the silicon process.
- (4) The maximum junction temperature for continuous operation is limited by package constraints. Operation above this temperature may result in reduced reliability and/or lifetime of the device.
- (5) See the MSL/Reflow Rating information provided with the material, or see TI's web site at www.ti.com for the latest information.

DISSIPATION RATING TABLE

PACKAGE	$\theta_{JA}^{(1)}$ (°C/W)	θ_{JC} (°C/W)	POWER RATING ⁽²⁾	
			T _A = 25°C	T _A = 85°C
D	97.5	38.3	1.02 W	410 mW
DGN	58.4	4.7	1.71 W	685 mW
DGK	260	54.2	385 mW	154 mW

- (1) This data was taken using the JEDEC standard High-K test PCB.
(2) Power rating is determined with a junction temperature of 125°C. This is the point where distortion starts to substantially increase. Thermal management of the final PCB should strive to keep the junction temperature at or below 125°C for best performance and long term reliability.

RECOMMENDED OPERATING CONDITIONS

			MIN	TYP	MAX	UNIT
V _{CC+} to V _{CC-}	Supply voltage	Dual supply	±2.5		±15	V
		Single supply	5		30	
T _A	Operating free-air temperature	C suffix	0		70	°C
		I suffix	–40		85	

ELECTRICAL CHARACTERISTICS

At V_{CC} = 15 V, R_L = 800 Ω, T_A = 25°C (unless otherwise noted).

PARAMETER		TEST CONDITIONS		MIN	TYP	MAX	UNIT
DYNAMIC PERFORMANCE							
BW	Small-signal bandwidth (–3 dB)	V _{CC} = 5	Gain = 1, R _f = 390 Ω		150		MHz
		V _{CC} = ±5			150		
		V _{CC} = ±15			150		
BW	Small-signal bandwidth (–3 dB)	V _{CC} = 5	Gain = 2, R _f = 750 Ω		80		MHz
		V _{CC} = ±5			81		
		V _{CC} = ±15			81		
SR	Slew rate ⁽¹⁾	V _{CC} = ±15,	Gain = 1		650		V/μs
t _s	Settling time to 0.1%	Differential step voltage = 2 V _{PP} , Gain = 1			53		ns
	Settling time to 0.01%				247		
DISTORTION PERFORMANCE							
THD	Total harmonic distortion Differential input, differential output Gain = 1, R _f = 390 Ω, R _L = 800 Ω, V _O = 2 V _{PP}	V _{CC} = 5	f = 1 MHz		–85		dB
			f = 8 MHz		–66		
		V _{CC} = ±5	f = 1 MHz		–83		
			f = 8 MHz		–65		
		V _{CC} = ±15	f = 1 MHz		–84		
			f = 8 MHz		–65		
Spurious free dynamic range (SFDR)		V _O = 2 V _{PP} ,	f = 1 MHz		–87		dB
Third intermodulation distortion		V _O = 0.14 V _{RMS} , Gain = 1, f = 20 MHz			–95		dBc
NOISE PERFORMANCE							
V _n	Input voltage noise	f > 10 kHz			7.6		nV/√Hz
I _n	Input current noise	f > 10 kHz			1.78		pA/√Hz

- (1) Slew rate is measured from an output level range of 25% to 75%.

ELECTRICAL CHARACTERISTICS (continued)

At $V_{CC} = 15\text{ V}$, $R_L = 800\ \Omega$, $T_A = 25^\circ\text{C}$ (unless otherwise noted).

PARAMETER		TEST CONDITIONS	MIN	TYP	MAX	UNIT
DC PERFORMANCE						
Open loop gain		$T_A = 25^\circ\text{C}$	63	67		dB
		$T_A = \text{full range}^{(2)}$	60			
V_{OS}	Input offset voltage	$T_A = 25^\circ\text{C}$		1.1	7	mV
		$T_A = \text{full range}$			8.5	
	Input offset voltage, referred to V_{OCM}	$T_A = 25^\circ\text{C}$		0.6	8	
	Offset drift	$T_A = \text{full range}$		7		$\mu\text{V}/^\circ\text{C}$
I_{IB}	Input bias current	$T_A = \text{full range}$		4.3	15	μA
I_{OS}	Input offset current			250	1200	nA
	Offset drift	$T_A = \text{full range}$		0.7		$\text{nA}/^\circ\text{C}$
	Shutdown delay to output	$T_A = \text{full range}$		1.1		μs
INPUT CHARACTERISTICS						
CMRR	Common-mode rejection ratio	$T_A = \text{full range}$	-75	-83		dB
V_{ICR}	Common-mode input voltage range			$V_{S-} +1.5\text{V}$ to $V_{S+} -1.5\text{V}$		V
r_i	Input resistance	Measured into each input terminal		14.4		M Ω
C_i	Input capacitance, closed loop			3.9		pF
r_o	Output resistance	Open loop/single ended		0.4		Ω
$r_{o(SD)}$	Output resistance	Shutdown		636		Ω
OUTPUT CHARACTERISTICS						
Output voltage swing		$V_{CC} = 5\text{ V}$	$T_A = 25^\circ\text{C}$	1.2 to 3.8	0.9 to 4.1	V
			$T_A = \text{full range}$	1.2 to 3.8		
		$V_{CC} = \pm 5\text{ V}$	$T_A = 25^\circ\text{C}$	± 3.7	± 3.9	
			$T_A = \text{full range}$	± 3.6		
$V_{CC} = \pm 15\text{ V}$	$T_A = 25^\circ\text{C}$	± 11.6	± 12.7			
	$T_A = \text{full range}$	± 11				
I_O Output current, $R_L = 70\ \Omega$		$V_{CC} = 5\text{ V}$	$T_A = 25^\circ\text{C}$	30	45	mA
			$T_A = \text{full range}$	25		
		$V_{CC} = \pm 5\text{ V}$	$T_A = 25^\circ\text{C}$	45	60	
			$T_A = \text{full range}$	35		
		$V_{CC} = \pm 15\text{ V}$	$T_A = 25^\circ\text{C}$	65	85	
			$T_A = \text{full range}$	50		
POWER-SUPPLY						
V_{CC}	Supply voltage range	Single supply	4	30	33	V
		Split supply	± 2	± 15	± 16.5	
I_{CC}	Quiescent current (per amplifier)	$V_{CC} = \pm 5\text{ V}$	$T_A = 25^\circ\text{C}$	15.8	18.5	mA
			$T_A = \text{full range}$		21	
		$V_{CC} = \pm 15\text{ V}$	$T_A = 25^\circ\text{C}$	17.5	21	
			$T_A = \text{full range}$		23	
$I_{CC(SD)}$	Quiescent current (shutdown) (THS4150) ⁽³⁾	$T_A = 25^\circ\text{C}$		1	1.3	mA
		$T_A = \text{full range}$			1.5	
PSRR	Power-supply rejection ratio (dc)	$T_A = 25^\circ\text{C}$	70	90		dB
		$T_A = \text{full range}$	65			

(2) The full range temperature is 0°C to 70°C for the C suffix, and -40°C to 85°C for the I suffix.

(3) For detailed information on the behavior of the power-down circuit, see the [Power-down mode](#) description in the [Principles of Operation](#) section of this data sheet.

TYPICAL CHARACTERISTICS

Table of Graphs

			FIGURE
	Small-signal frequency response		1, 2
	Large-signal frequency response		3
	Settling time		4
SR	Slew rate	vs Temperature	5
	Total harmonic distortion	vs Frequency	6
		vs Output voltage	7
	Harmonic distortion	vs Frequency	8–13
		vs Output voltage	14–17
	Third intermodulation distortion	vs Output voltage	18
V_n	Voltage noise	vs Frequency	19
I_n	Current noise	vs Frequency	20
V_O	Output voltage	vs Single-ended load resistance	21
	Power supply current shutdown	vs Supply voltage	22
	Output current range	vs Supply voltage	23
V_{OS}	Single-ended output offset voltage	vs Common-mode output voltage	24
CMRR	Common-mode rejection ratio	vs Frequency	25
z	Impedance of the V_{OCM} terminal	vs Frequency	26
z_o	Output impedance (powered up)	vs Frequency	27
z_o	Output impedance (shutdown)	vs Frequency	28
PSRR	Power-supply rejection ratio	vs Frequency	29

TYPICAL CHARACTERISTICS

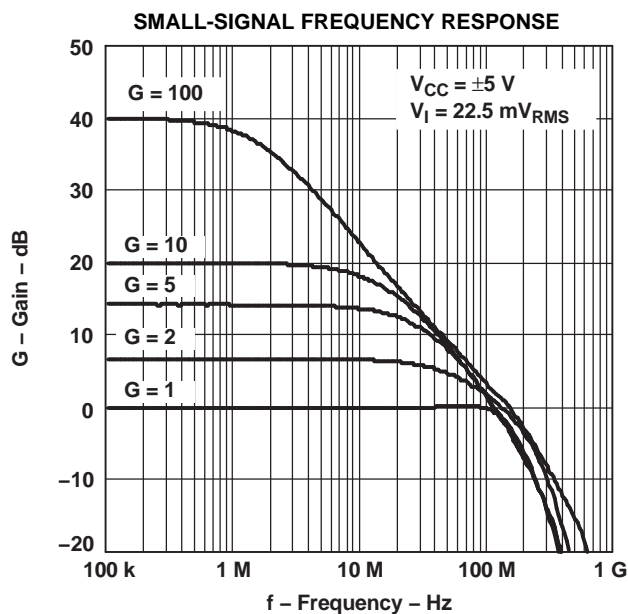

Figure 1.

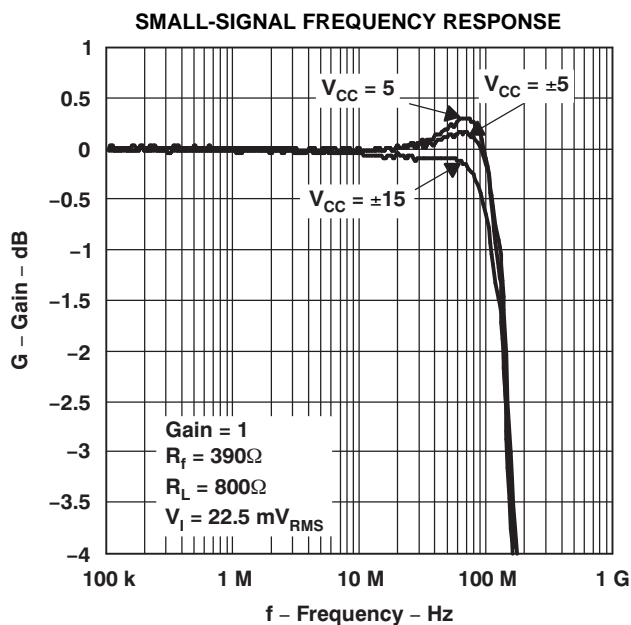

Figure 2.

TYPICAL CHARACTERISTICS (continued)

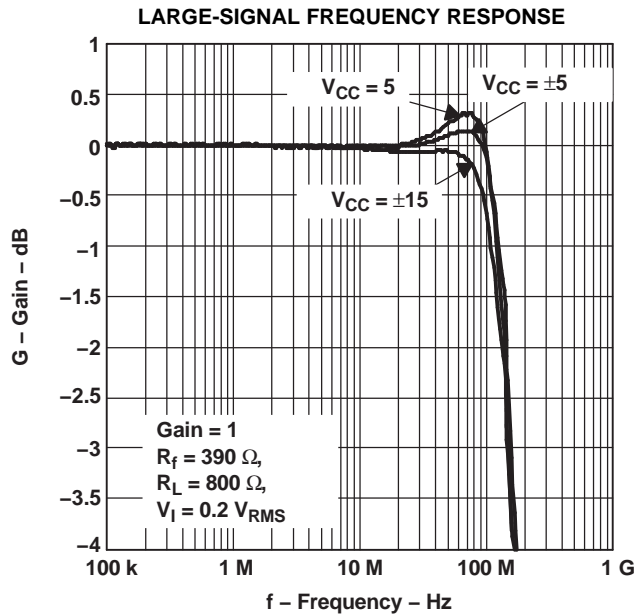

Figure 3.

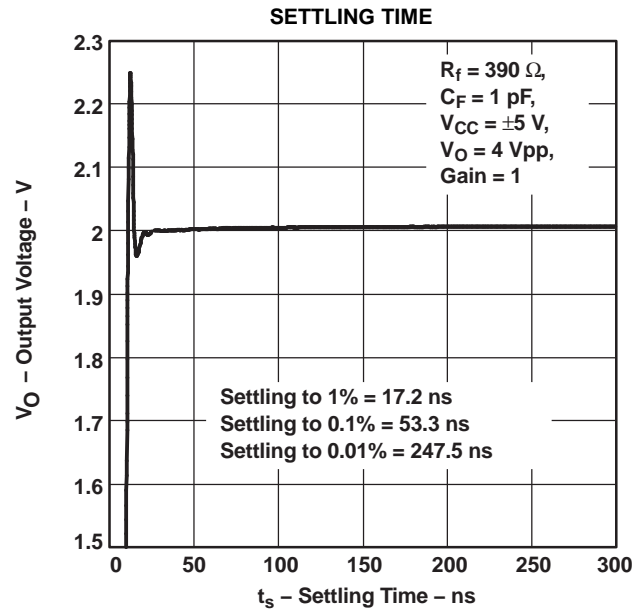

Figure 4.

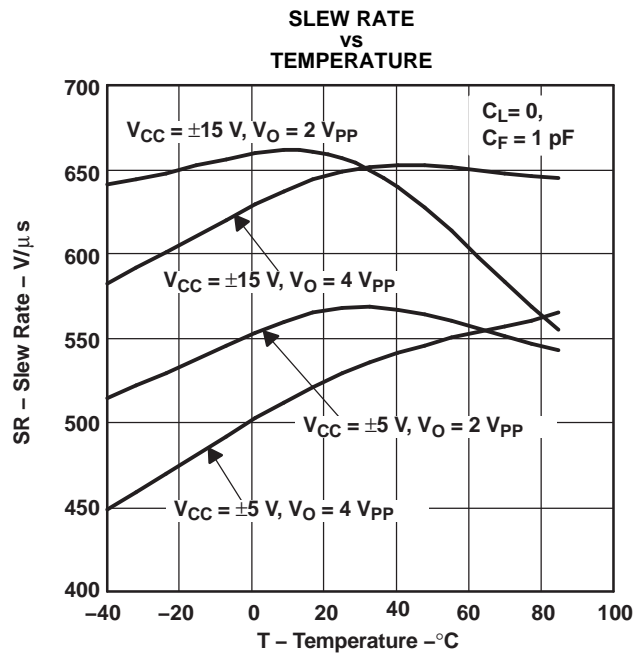

Figure 5.

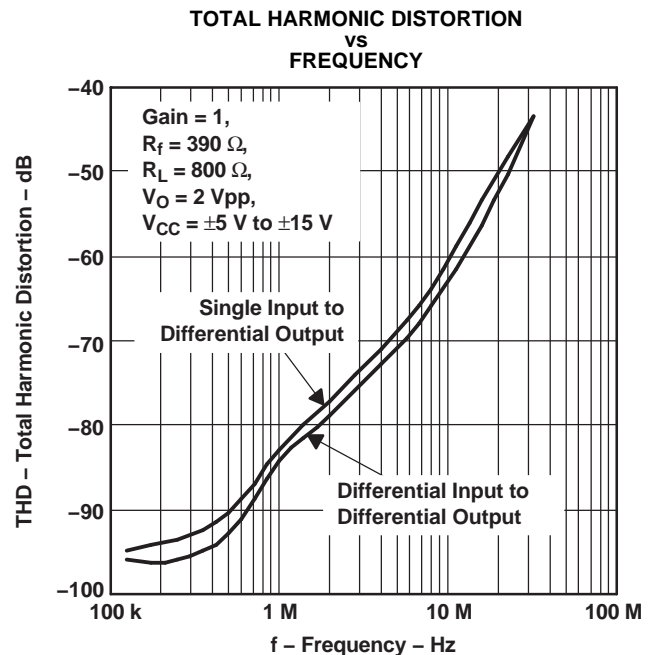
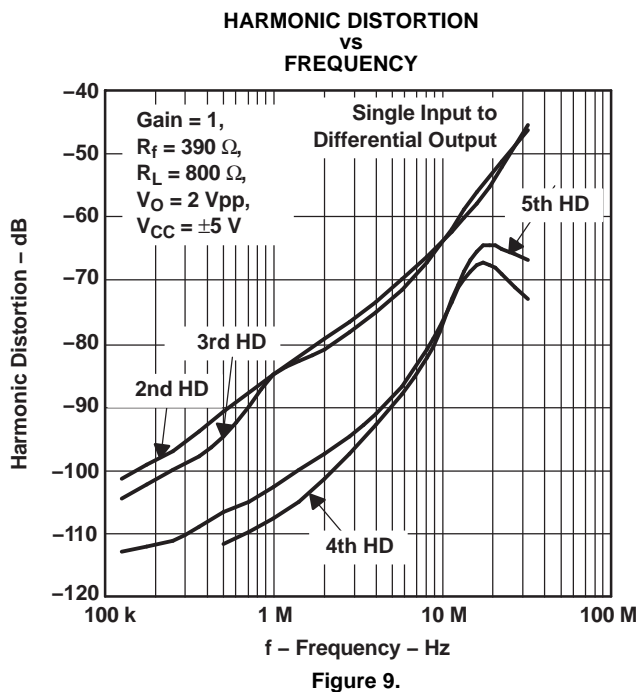
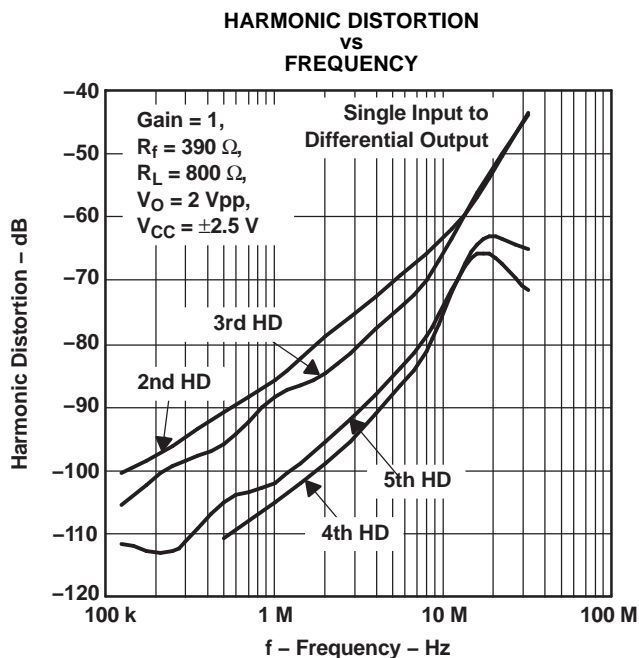
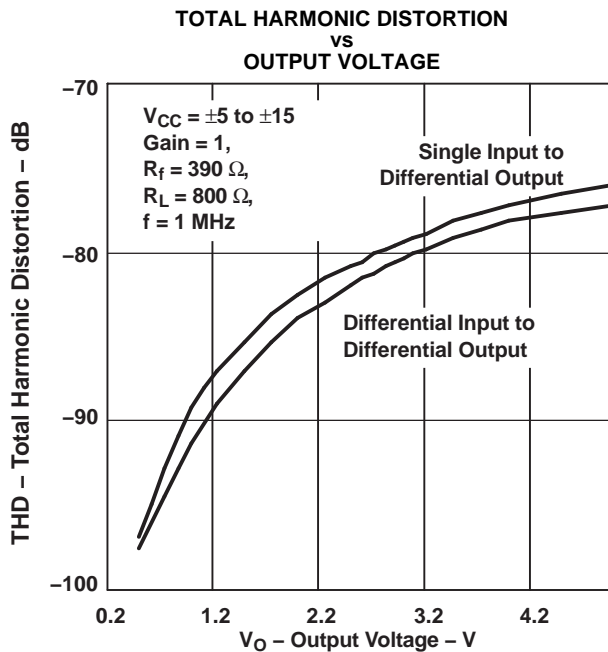

Figure 6.

TYPICAL CHARACTERISTICS (continued)



TYPICAL CHARACTERISTICS (continued)

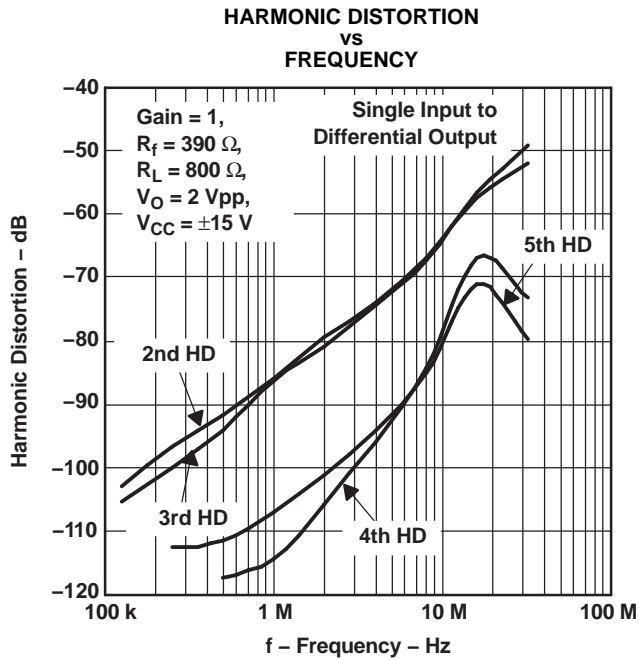

Figure 10.

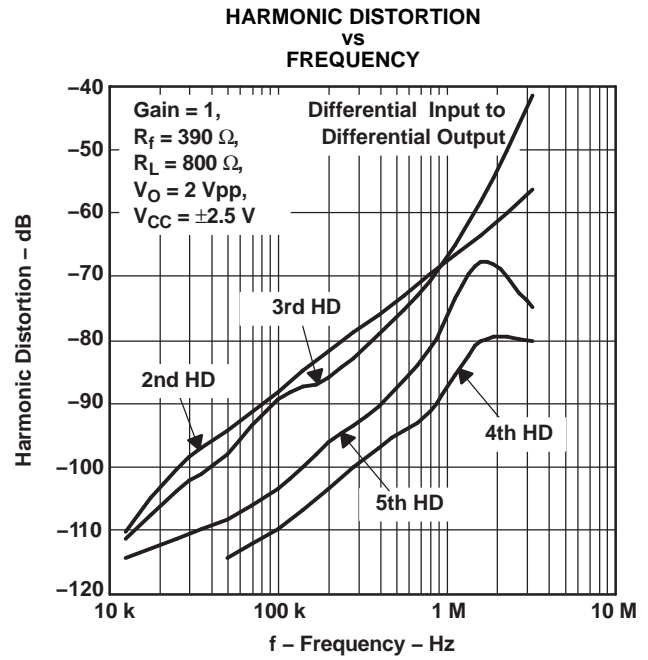

Figure 11.

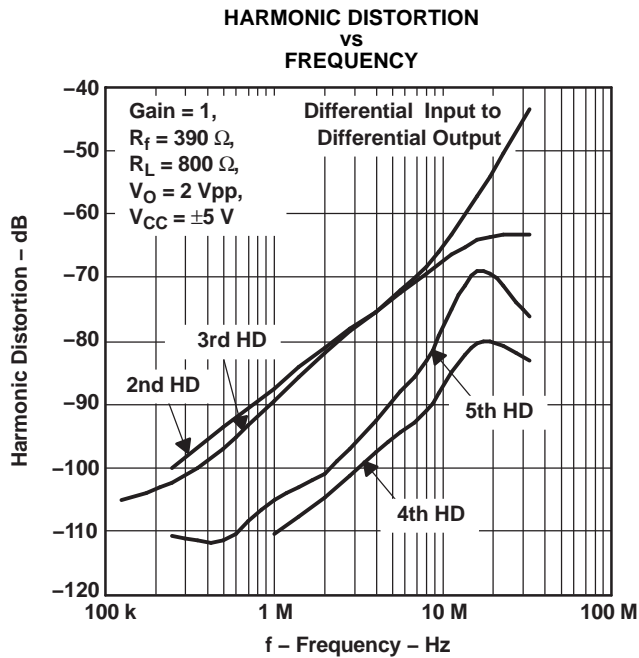

Figure 12.

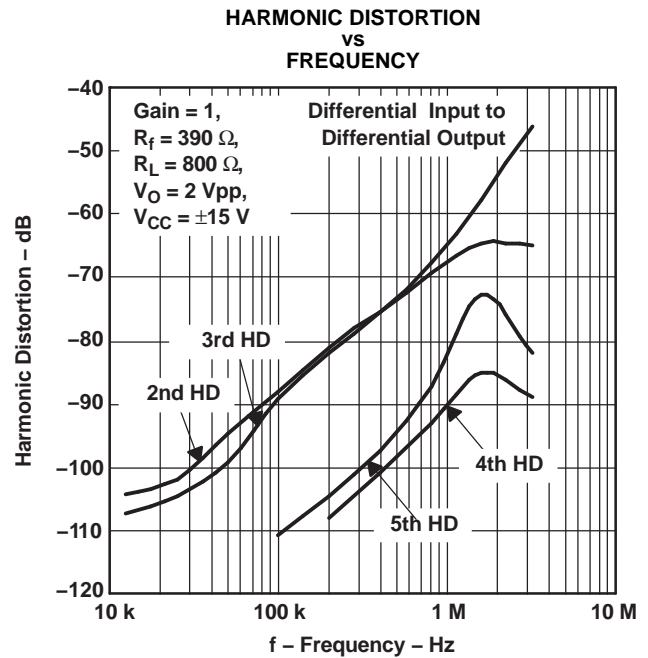

Figure 13.

TYPICAL CHARACTERISTICS (continued)

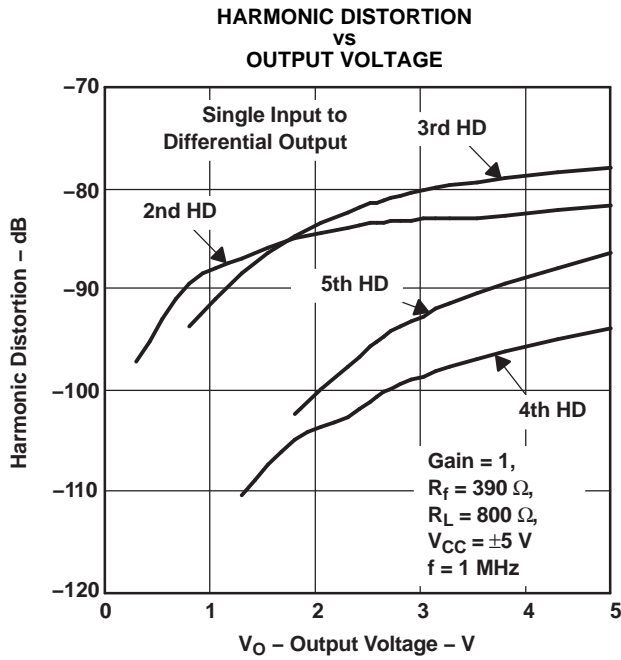

Figure 14.

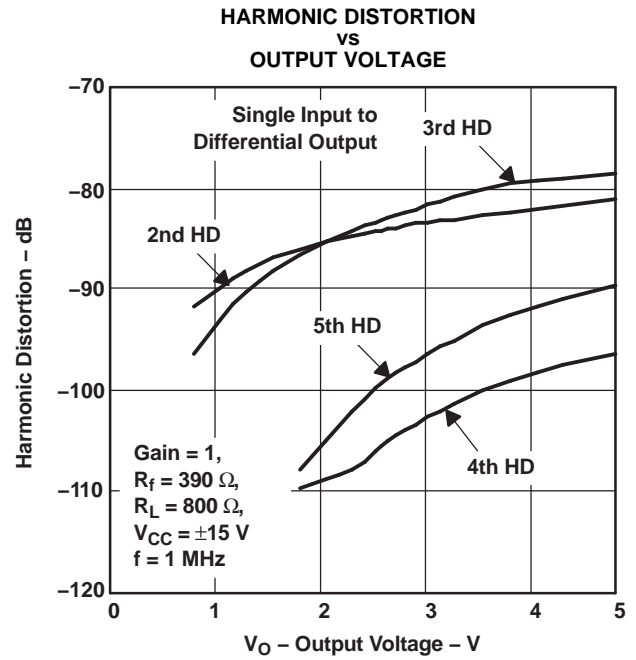

Figure 15.

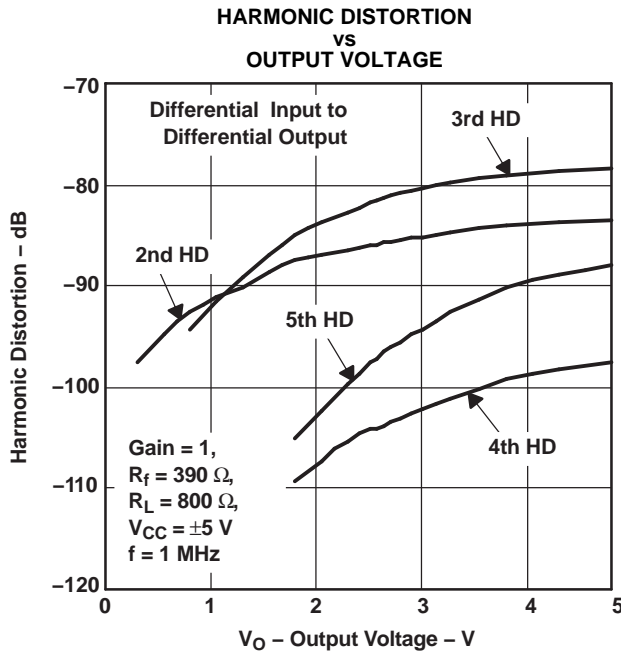

Figure 16.

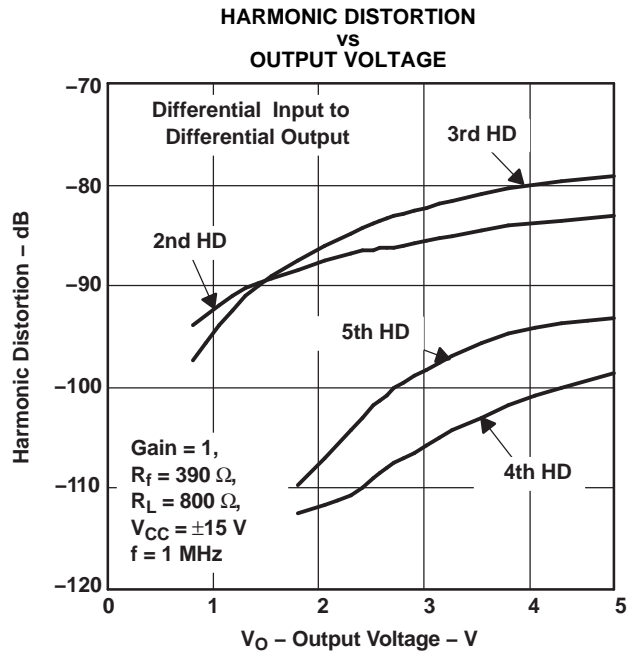

Figure 17.

TYPICAL CHARACTERISTICS (continued)

THIRD INTERMODULATION DISTORTION
vs
OUTPUT VOLTAGE

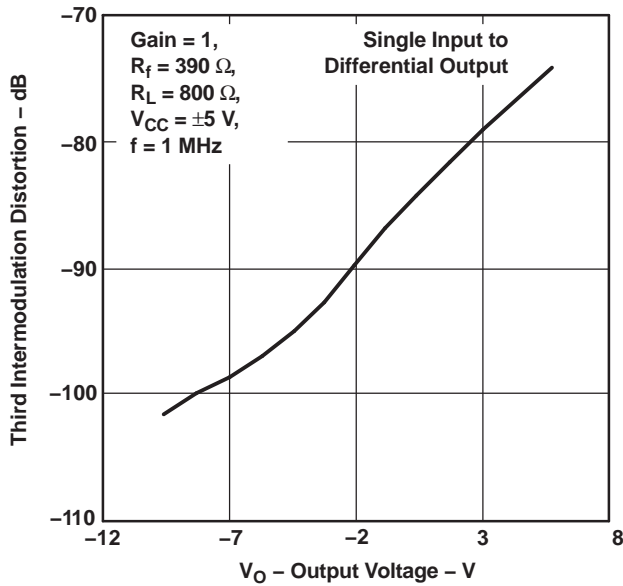

Figure 18.

VOLTAGE NOISE
vs
FREQUENCY

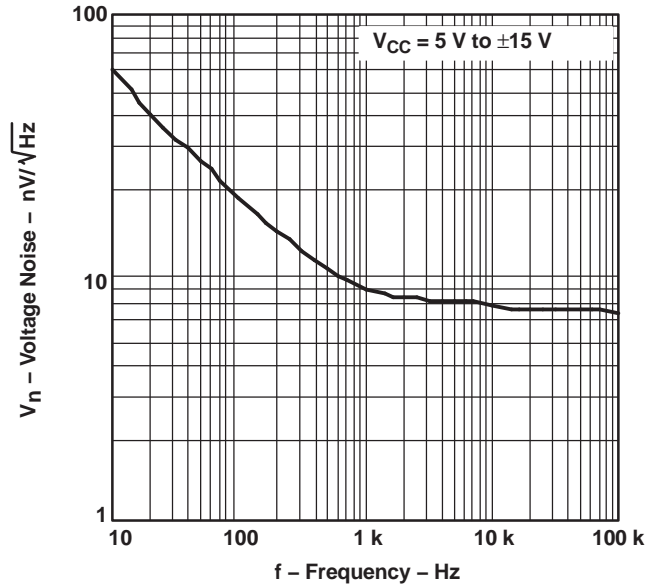

Figure 19.

CURRENT NOISE
vs
FREQUENCY

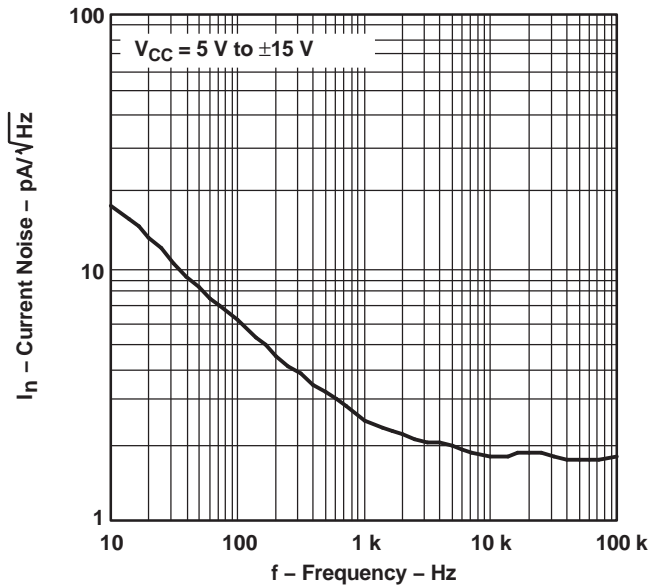

Figure 20.

OUTPUT VOLTAGE
vs
SINGLE-ENDED LOAD RESISTANCE

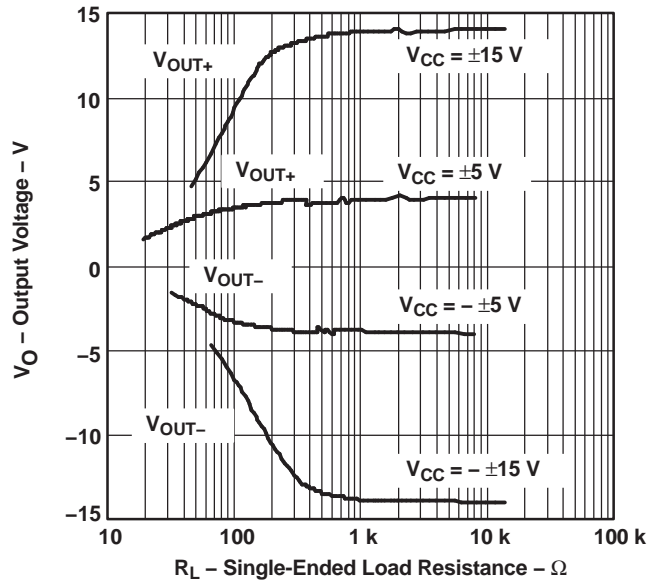

Figure 21.

TYPICAL CHARACTERISTICS (continued)

POWER-SUPPLY CURRENT SHUTDOWN
vs
SUPPLY VOLTAGE

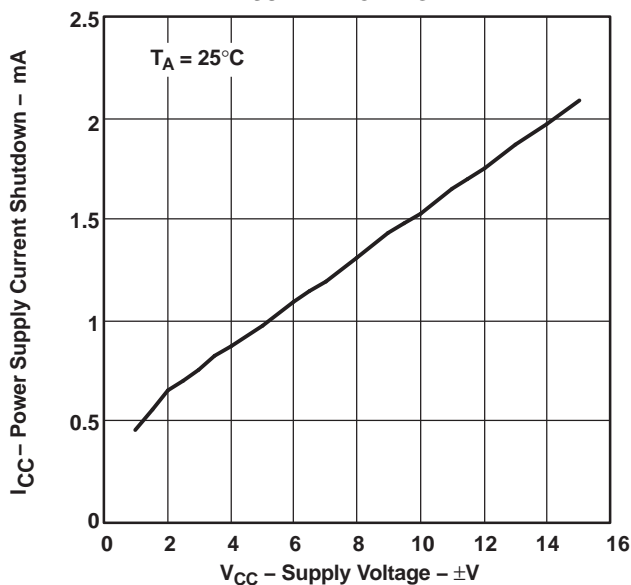

Figure 22.

OUTPUT CURRENT RANGE
vs
SUPPLY VOLTAGE

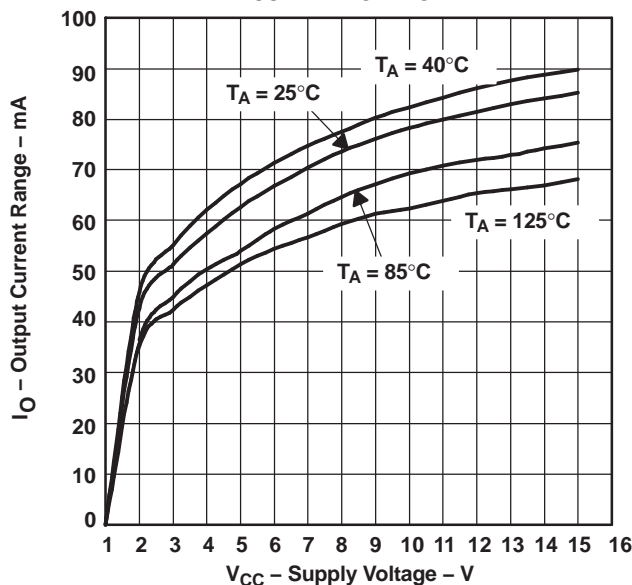

Figure 23.

SINGLE-ENDED OUTPUT OFFSET VOLTAGE
vs
COMMON-MODE OUTPUT VOLTAGE

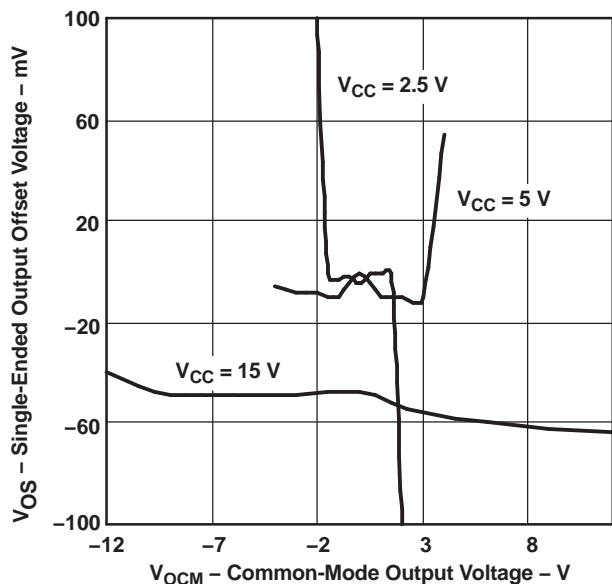

Figure 24.

COMMON-MODE REJECTION RATIO
vs
FREQUENCY

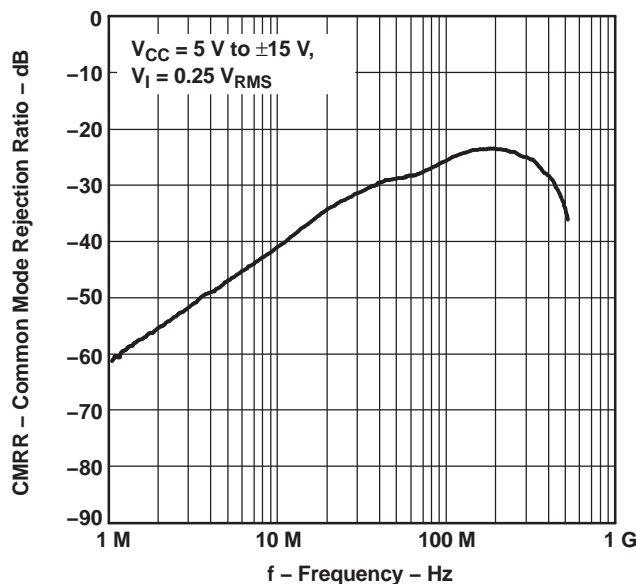

Figure 25.

TYPICAL CHARACTERISTICS (continued)

IMPEDANCE OF THE V_{OCM} TERMINAL
VS
FREQUENCY

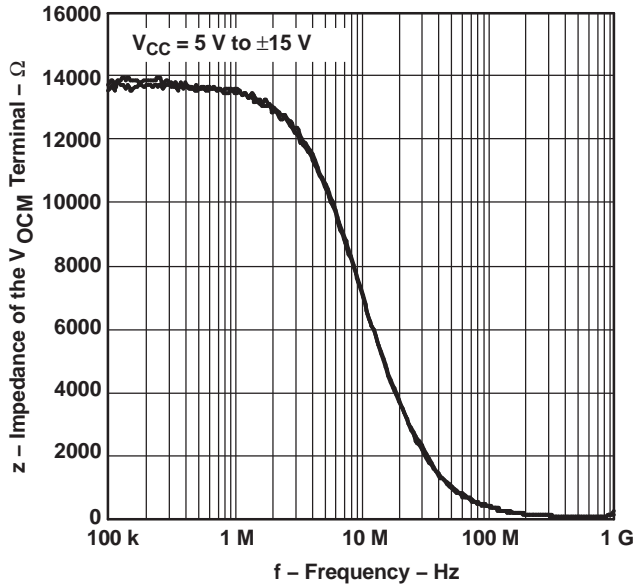

Figure 26.

OUTPUT IMPEDANCE (POWERED UP)
VS
FREQUENCY

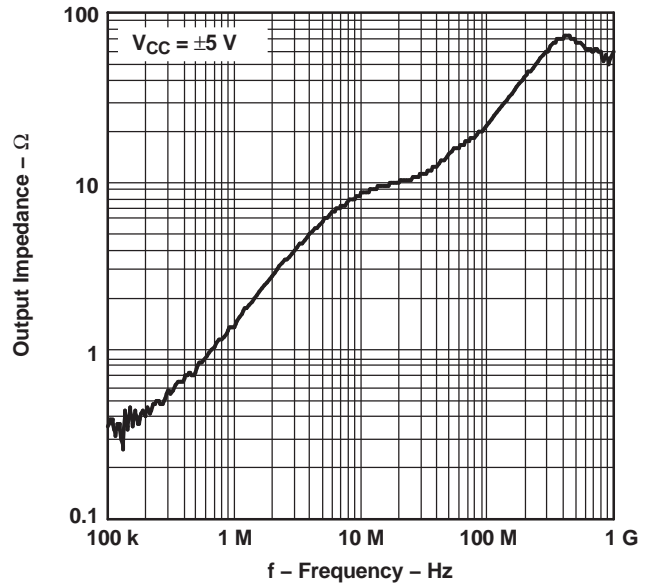

Figure 27.

OUTPUT IMPEDANCE (SHUTDOWN)
VS
FREQUENCY

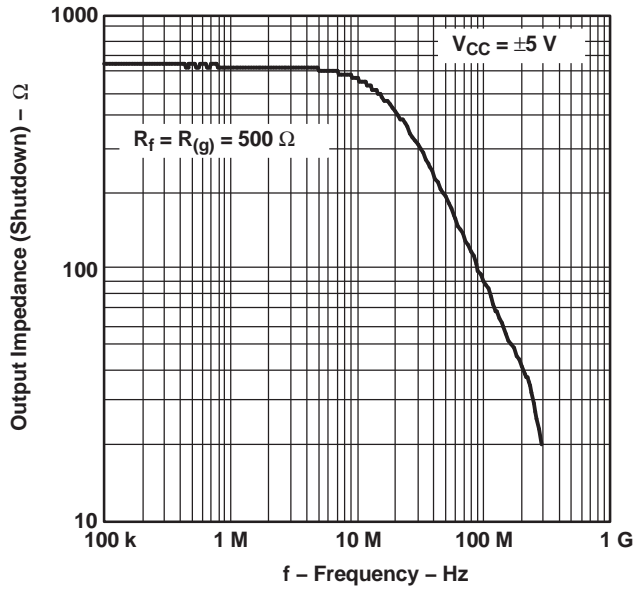

Figure 28.

POWER-SUPPLY REJECTION RATIO
VS
FREQUENCY

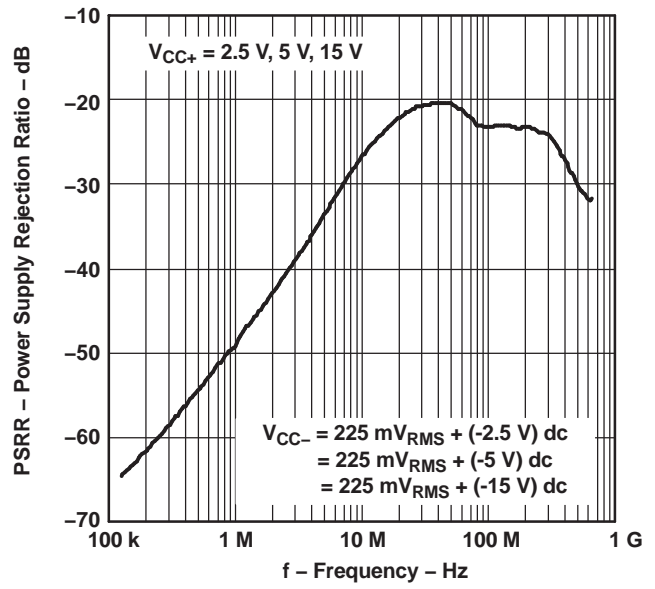

Figure 29.

APPLICATION INFORMATION

RESISTOR MATCHING

Resistor matching is important in fully differential amplifiers. The balance of the output on the reference voltage depends on matched ratios of the resistors. CMRR, PSRR, and cancellation of the second harmonic distortion will diminish if resistor mismatch occurs. Therefore, it is recommended to use 1% tolerance resistors or better to keep the performance optimized.

V_{OCM} sets the dc level of the output signals. If no voltage is applied to the V_{OCM} pin, it will be set to the midrail voltage internally defined as:

$$\frac{(V_{CC+}) + (V_{CC-})}{2}$$

In the differential mode, the V_{OCM} on the two outputs cancel each other. Therefore, the output in the differential mode is the same as the input when gain is 1. V_{OCM} has a high bandwidth capability up to the typical operating range of the amplifier. For the prevention of noise going through the device, use a 0.1- μ F capacitor on the V_{OCM} pin as a bypass capacitor. Figure 30 shows the simplified diagram of the THS415x.

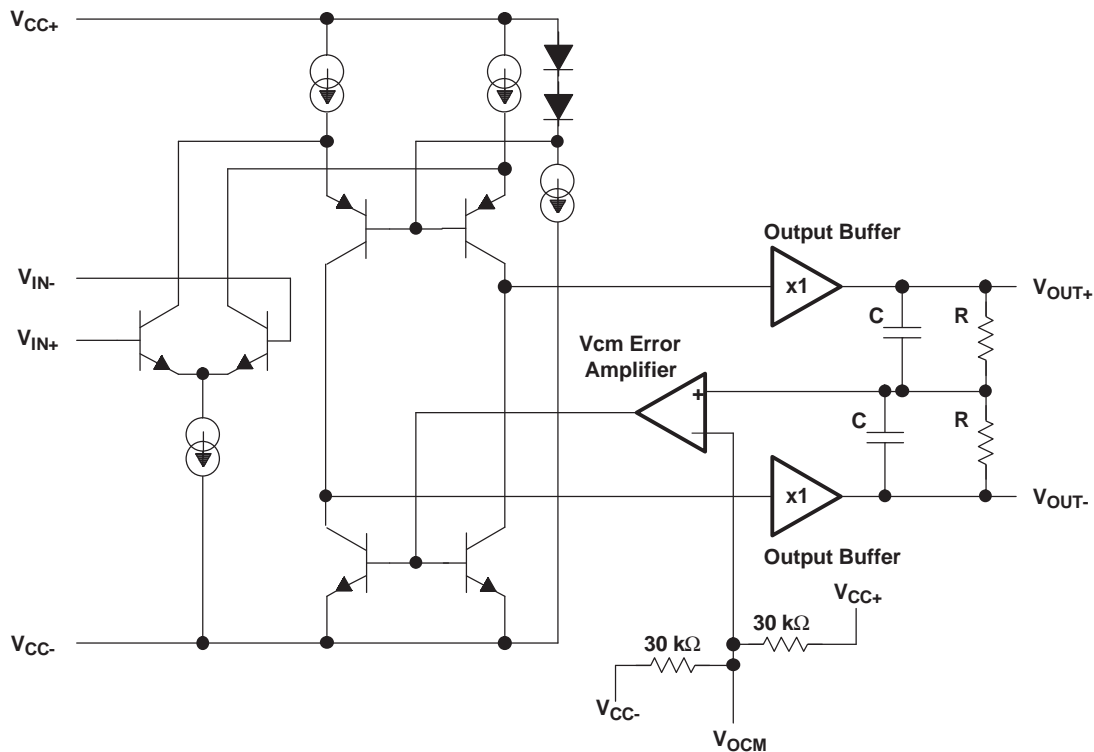

Figure 30. THS415x Simplified Diagram

DATA CONVERTERS

Data converters are one of the most popular applications for the fully differential amplifiers. The following schematic shows a typical configuration of a fully differential amplifier attached to a differential ADC.

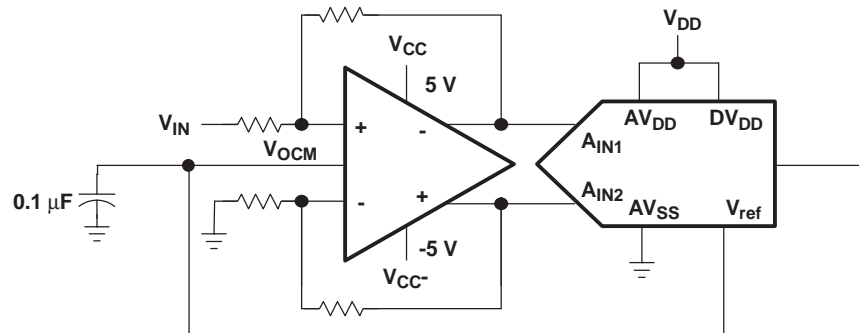

Figure 31. Fully Differential Amplifier Attached to a Differential ADC

Fully differential amplifiers can operate with a single supply. V_{OCM} defaults to the midrail voltage, $V_{CC}/2$. The differential output may be fed into a data converter. This method eliminates the use of a transformer in the circuit. If the ADC has a reference voltage output (V_{ref}), then it is recommended to connect it directly to the V_{OCM} of the amplifier using a bypass capacitor for stability. For proper operation, the input common-mode voltage to the input terminal of the amplifier should not exceed the common-mode input voltage range.

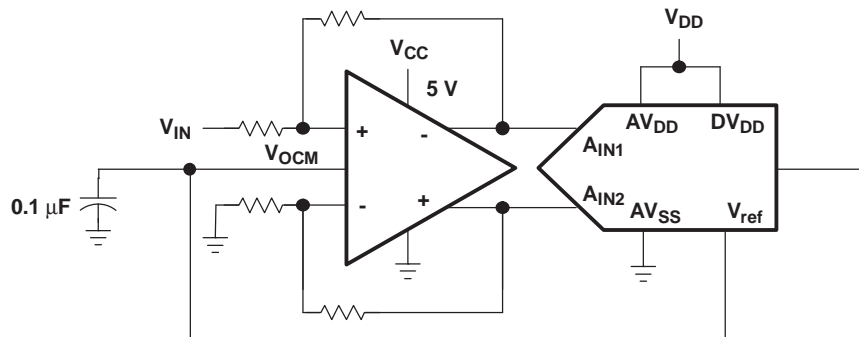

Figure 32. Fully Differential Amplifier Using a Single-Supply

Some single-supply applications may require the input voltage to exceed the common-mode input voltage range. In such cases, the following circuit configuration is suggested to bring the common-mode input voltage within the specifications of the amplifier.

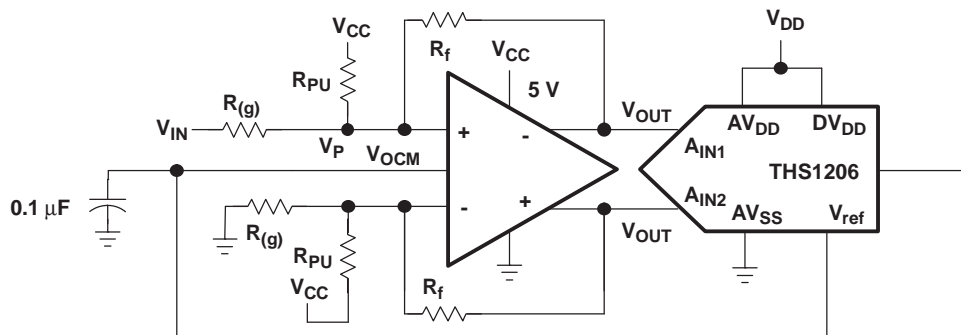

Figure 33. Circuit With Improved Common-Mode Input Voltage

The following equation is used to calculate R_{PU} :

$$R_{PU} = \frac{V_P - V_{CC}}{\left(V_{IN} - V_P\right) \frac{1}{R_G} + \left(V_{OUT} - V_P\right) \frac{1}{R_F}}$$

DRIVING A CAPACITIVE LOAD

Driving capacitive loads with high-performance amplifiers is not a problem as long as certain precautions are taken. The first is to realize that the THS415x has been internally compensated to maximize its bandwidth and slew rate performance. When the amplifier is compensated in this manner, capacitive loading directly on the output will decrease the device's phase margin leading to high-frequency ringing or oscillations. Therefore, for capacitive loads of greater than 10 pF, it is recommended that a resistor be placed in series with the output of the amplifier, as shown in Figure 34. A minimum value of 20 Ω should work well for most applications. For example, in 50-Ω transmission systems, setting the series resistor value to 20 Ω both isolates any capacitance loading and provides the proper line impedance matching at the source end.

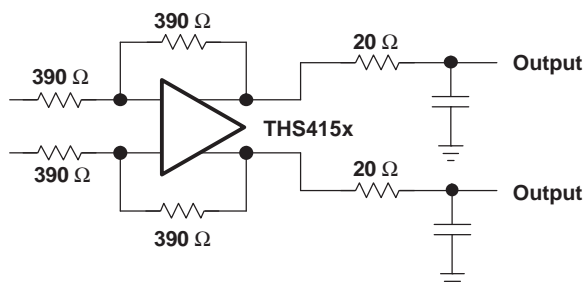

Figure 34. Driving a Capacitive Load

ACTIVE ANTIALIAS FILTERING

For signal conditioning in ADC applications, it is important to limit the input frequency to the ADC. Low-pass filters can prevent the aliasing of the high frequency noise with the frequency of operation. Figure 35 presents a method by which the noise may be filtered in the THS415x.

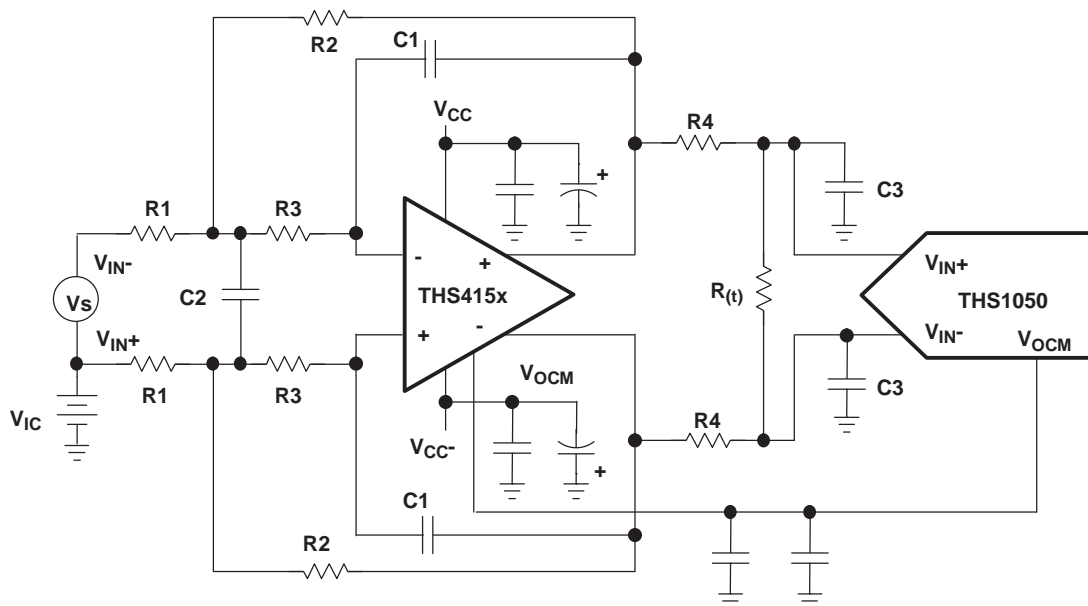

Figure 35. Antialias Filtering

The transfer function for this filter circuit is:

$$H_d(f) = \left[\frac{K}{-\left(\frac{f}{FSF \times f_c}\right)^2 + \frac{1}{Q} \frac{jf}{FSF \times f_c} + 1} \right] \times \left[\frac{\frac{R_t}{2R_4 + R_t}}{1 + \frac{j2\pi f R_4 R_t C_3}{2R_4 + R_t}} \right] \quad \text{Where } K = \frac{R_2}{R_1}$$

$$FSF \times f_c = \frac{1}{2\pi\sqrt{2 \times R_2 R_3 C_1 C_2}} \quad \text{and } Q = \frac{\sqrt{2 \times R_2 R_3 C_1 C_2}}{R_3 C_1 + R_2 C_1 + K R_3 C_1}$$

K sets the pass band gain, f_c is the cutoff frequency for the filter, FSF is a frequency-scaling factor, and Q is the quality factor.

$$FSF = \sqrt{\text{Re}^2 + |\text{Im}|^2} \quad \text{and } Q = \frac{\sqrt{\text{Re}^2 + |\text{Im}|^2}}{2\text{Re}}$$

where Re is the real part, and Im is the imaginary part of the complex pole pair. Setting $R_2 = R$, $R_3 = mR$, $C_1 = C$, and $C_2 = nC$ results in:

$$FSF \times f_c = \frac{1}{2\pi RC \sqrt{2 \times mn}} \quad \text{and } Q = \frac{\sqrt{2 \times mn}}{1 + m(1 + K)}$$

Start by determining the ratios, m and n, required for the gain and Q of the filter type being designed, then select C and calculate R for the desired f_c .

PRINCIPLES OF OPERATION

THEORY OF OPERATION

The THS415x is a fully differential amplifier. Differential amplifiers are typically *differential in/single out*, whereas fully differential amplifiers are *differential in/differential out*.

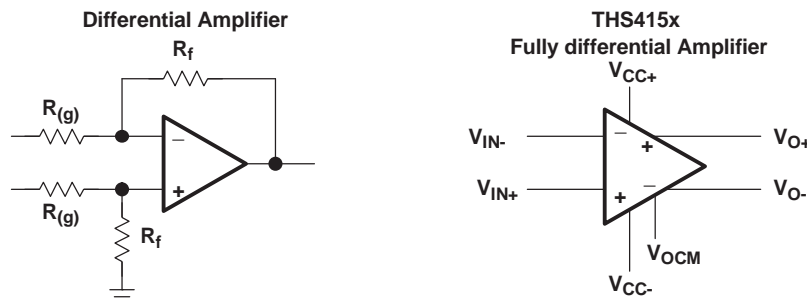

Figure 36. Differential Amplifier Versus a Fully Differential Amplifier

To understand the THS415x fully differential amplifiers, the definition for the pinouts of the amplifier are provided.

Input voltage definition $V_{ID} = (V_{I+}) - (V_{I-})$ $V_{IC} = \frac{(V_{I+}) + (V_{I-})}{2}$

Output voltage definition $V_{OD} = (V_{O+}) - (V_{O-})$ $V_{OC} = \frac{(V_{O+}) + (V_{O-})}{2}$

Transfer function $V_{OD} = V_{ID} \times A_{(f)}$

Output common mode voltage $V_{OC} = V_{OCM}$

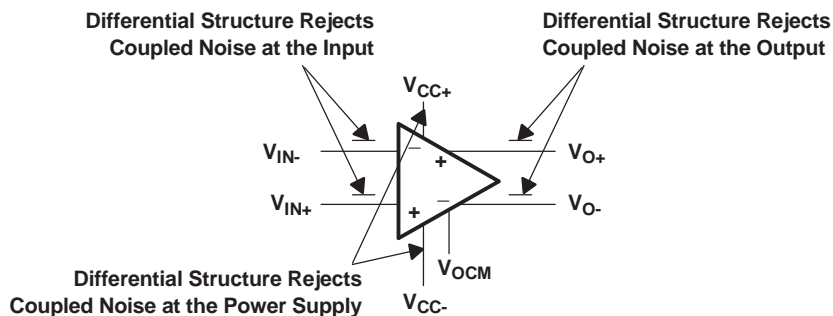
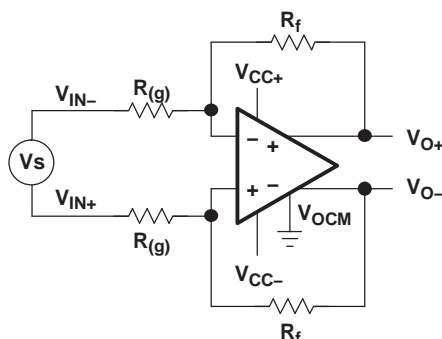

Figure 37. Definition of the Fully Differential Amplifier

The following schematics depict the differences between the operation of the THS415x, a fully differential amplifier, in two different modes. Fully differential amplifiers can work with differential input or can be implemented as single in/differential out.



Note: For proper operation, maintain symmetry by setting $R_{f1} = R_{f2} = R_f$ and $R_{(g)1} = R_{(g)2} = R_{(g)} \Rightarrow A = R_f/R_{(g)}$

Figure 38. Amplifying Differential Signals

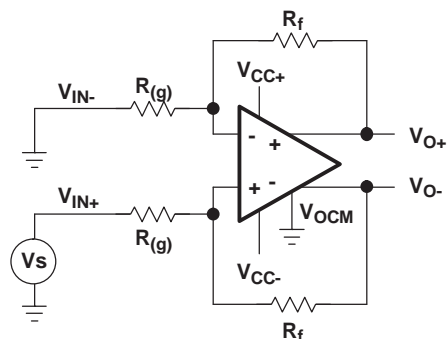

RECOMMENDED RESISTOR VALUES

GAIN	$R_{(g)}$ Ω	R_f Ω
1	390	390
2	374	750
5	402	2010
10	402	4020

Figure 39. Single In With Differential Out

If each output is measured independently, each output is one-half of the input signal when the gain is 1. The following equations express the transfer function for each output:

$$V_{O+} = \frac{V_{I+}}{2} + V_{OCM}$$

The second output is equal and opposite in sign:

$$V_{O-} = \frac{-V_{I+}}{2} + V_{OCM}$$

V_{OCM} will be set to midrails if it is not derived by any external power source.

Fully differential amplifiers may be viewed as two inverting amplifiers. In this case, the equation of an inverting amplifier holds true for gain calculations. One advantage of fully differential amplifiers is that they offer twice as much dynamic range compared to single-ended amplifiers. For example, a $1-V_{PP}$ ADC can only support an input signal of $1 V_{PP}$. If the output of the amplifier is $2 V_{PP}$, then it will not be practical to feed a $2-V_{PP}$ signal into the targeted ADC. Using a fully differential amplifier enables the user to break down the output into two $1-V_{PP}$ signals with opposite signs and feed them into the differential input nodes of the ADC. In practice, the designer has been able to feed a $2-V$ peak-to-peak signal into a $1-V$ differential ADC with the help of a fully differential amplifier. The final result indicates twice as much dynamic range.

Figure 40 illustrates the increase in dynamic range. The gain factor should be considered in this scenario. The THS415x fully differential amplifier offers an improved CMRR and PSRR due to its symmetrical input and output. Furthermore, second harmonic distortion is improved. Second harmonics tend to cancel because of the symmetrical output.

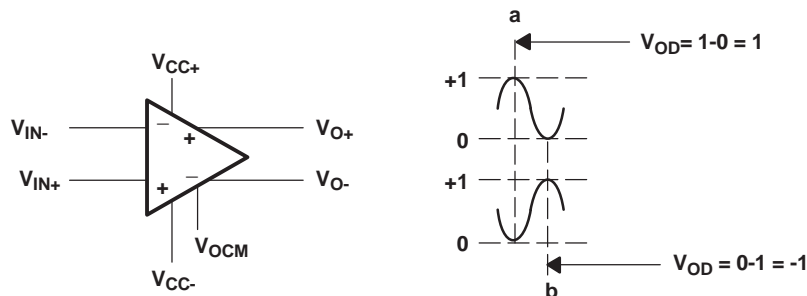

Figure 40. Fully Differential Amplifier With Two $1-V_{PP}$ Signals

Similar to the standard inverting amplifier configuration, input impedance of a fully differential amplifier is selected by the input resistor, $R_{(g)}$. If input impedance is a constraint in design, the designer may choose to implement the differential amplifier as an instrumentation amplifier. This configuration improves the input impedance of the fully differential amplifier. The following schematic depicts the general format of instrumentation amplifiers.

The general transfer function for this circuit is:

$$\frac{V_{OD}}{V_{IN1} - V_{IN2}} = \frac{R_f}{R_{(g)}} \left(1 + \frac{2R_2}{R_1} \right)$$

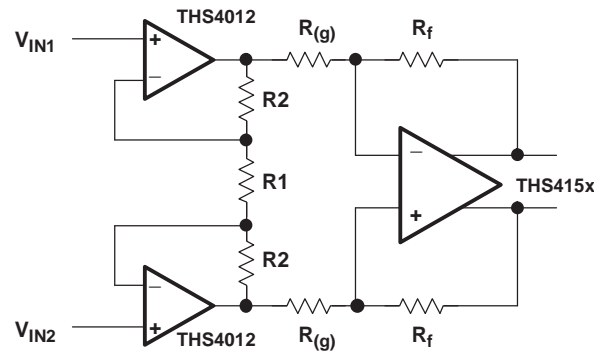

Figure 41. Fully Differential Instrumentation Amplifier

CIRCUIT LAYOUT CONSIDERATIONS

To achieve the levels of high frequency performance of the THS415x, follow proper printed-circuit board high frequency design techniques. A general set of guidelines is given below. In addition, a THS415x evaluation board is available to use as a guide for layout or for evaluating the device performance.

- **Ground planes**—It is highly recommended that a ground plane be used on the board to provide all components with a low inductive ground connection. However, in the areas of the amplifier inputs and output, the ground plane can be removed to minimize the stray capacitance.
- **Proper power supply decoupling**—Use a 6.8- μ F tantalum capacitor in parallel with a 0.1- μ F ceramic capacitor on each supply terminal. It may be possible to share the tantalum among several amplifiers depending on the application, but a 0.1- μ F ceramic capacitor should always be used on the supply terminal of every amplifier. In addition, the 0.1- μ F capacitor should be placed as close as possible to the supply terminal. As this distance increases, the inductance in the connecting trace makes the capacitor less effective. The designer should strive for distances of less than 0.1 inches between the device power terminals and the ceramic capacitors.
- **Sockets**—Sockets are not recommended for high-speed operational amplifiers. The additional lead inductance in the socket pins will often lead to stability problems. Surface-mount packages soldered directly to the printed-circuit board is the best implementation.
- **Short trace runs/compact part placements**—Optimum high frequency performance is achieved when stray series inductance has been minimized. To realize this, the circuit layout should be made as compact as possible, thereby minimizing the length of all trace runs. Particular attention should be paid to the inverting input of the amplifier. Its length should be kept as short as possible. This will help to minimize stray capacitance at the input of the amplifier.
- **Surface-mount passive components**—Using surface-mount passive components is recommended for high frequency amplifier circuits for several reasons. First, because of the extremely low lead inductance of surface-mount components, the problem with stray series inductance is greatly reduced. Second, the small size of surface-mount components naturally leads to a more compact layout, thereby minimizing both stray inductance and capacitance. If leaded components are used, it is recommended that the lead lengths be kept as short as possible.

POWER-DOWN MODE

The power-down mode is used when power saving is required. The power-down terminal ($\overline{\text{PD}}$) found on the THS415x is an active low terminal. If it is left as a no-connect terminal, the device will always stay on due to an internal 50 k Ω resistor to V_{CC} . The threshold voltage for this terminal is approximately 1.4 V above $V_{\text{CC-}}$. This means that if the PD terminal is 1.4 V above $V_{\text{CC-}}$, the device is active. If the PD terminal is less than 1.4 V above $V_{\text{CC-}}$, the device is off. For example, if $V_{\text{CC-}} = -5$ V, then the device is on when PD reaches 3.6 V, (-5 V + 1.4 V = -3.6 V). By the same calculation, the device is off below -3.6 V. It is recommended to pull the terminal to $V_{\text{CC-}}$ in order to turn the device off. Figure 42 shows the simplified version of the power-down circuit. While in the power-down state, the amplifier goes into a high-impedance state. The amplifier output impedance is typically greater than 1 M Ω in the power-down state.

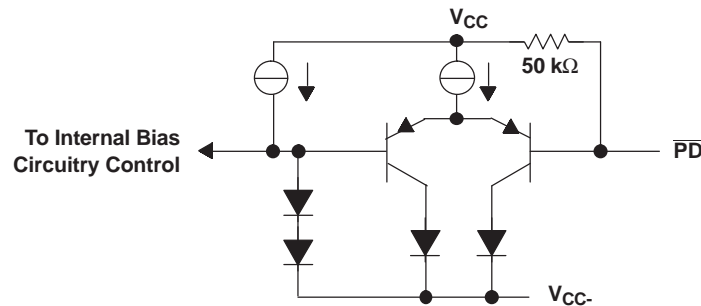

Figure 42. Simplified Power-Down Circuit

Due to the similarity of the standard inverting amplifier configuration, the output impedance appears to be very low while in the power-down state. This is because the feedback resistor (R_f) and the gain resistor ($R_{(g)}$) are still connected to the circuit. Therefore, a current path is allowed between the input of the amplifier and the output of the amplifier. An example of the closed-loop output impedance is shown in Figure 43.

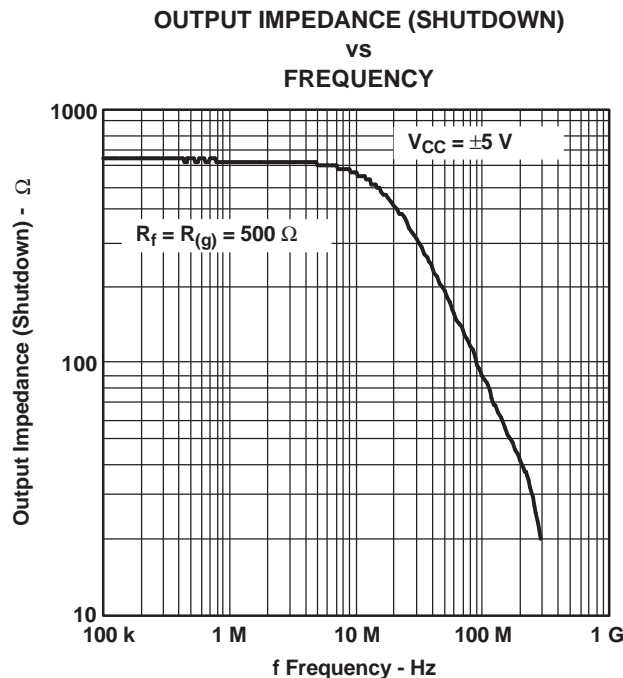

Figure 43.

GENERAL PowerPAD DESIGN

The THS415x is available packaged in a thermally-enhanced DGN package, which is a member of the PowerPAD family of packages. This package is constructed using a downset leadframe upon which the die is mounted [see Figure 44(a) and Figure 44(b)]. This arrangement results in the lead frame being exposed as a thermal pad on the underside of the package [see Figure 44(c)]. Because this thermal pad has direct thermal contact with the die, excellent thermal performance can be achieved by providing a good thermal path away from the thermal pad.

The PowerPAD package allows for both assembly and thermal management in one manufacturing operation. During the surface-mount solder operation (when the leads are being soldered), the thermal pad can also be soldered to a copper area underneath the package. Through the use of thermal paths within this copper area, heat can be conducted away from the package into either a ground plane or other heat dissipating device.

The PowerPAD package represents a breakthrough in combining the small area and ease of assembly of the surface mount with the, heretofore, awkward mechanical methods of heatsinking.

More complete details of the PowerPAD™ installation process and thermal management techniques can be found in the Texas Instruments Technical Brief, [PowerPAD Thermally Enhanced Package \(SLMA002\)](#). This document can be found at the TI web site (www.ti.com) by searching on the key word **PowerPAD**. The document can also be ordered through your local TI sales office. Refer to literature number SLMA002 when ordering.

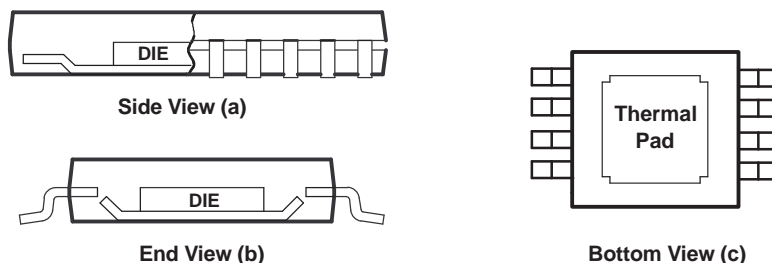

- A. The thermal pad is electrically isolated from all terminals in the package.

Figure 44. Views of Thermally Enhanced DGN Package

Revision History

NOTE: Page numbers for previous revisions may differ from page numbers in the current version.

Changes from Revision F (November, 2006) to Revision G	Page
• Corrected x-axis values in Figure 2	5

PACKAGING INFORMATION

Orderable Device	Status (1)	Package Type	Package Drawing	Pins	Package Qty	Eco Plan (2)	Lead finish/ Ball material (6)	MSL Peak Temp (3)	Op Temp (°C)	Device Marking (4/5)	Samples
THS4150CD	ACTIVE	SOIC	D	8	75	RoHS & Green	NIPDAU	Level-1-260C-UNLIM	0 to 70	4150C	Samples
THS4150CDGN	ACTIVE	HVSSOP	DGN	8	80	RoHS & Green	NIPDAU	Level-1-260C-UNLIM	0 to 70	AQB	Samples
THS4150CDGNR	ACTIVE	HVSSOP	DGN	8	2500	RoHS & Green	NIPDAU	Level-1-260C-UNLIM	0 to 70	AQB	Samples
THS4150CDR	ACTIVE	SOIC	D	8	2500	RoHS & Green	NIPDAU	Level-1-260C-UNLIM	0 to 70	4150C	Samples
THS4150ID	ACTIVE	SOIC	D	8	75	RoHS & Green	NIPDAU	Level-1-260C-UNLIM	-40 to 85	4150I	Samples
THS4150IDGN	ACTIVE	HVSSOP	DGN	8	80	RoHS & Green	NIPDAU	Level-1-260C-UNLIM	-40 to 85	AQC	Samples
THS4150IDGNR	ACTIVE	HVSSOP	DGN	8	2500	RoHS & Green	NIPDAU	Level-1-260C-UNLIM	-40 to 85	AQC	Samples
THS4151CD	ACTIVE	SOIC	D	8	75	RoHS & Green	NIPDAU	Level-1-260C-UNLIM	0 to 70	4151C	Samples
THS4151CDGK	ACTIVE	VSSOP	DGK	8	80	RoHS & Green	NIPDAU	Level-1-260C-UNLIM	0 to 70	ATU	Samples
THS4151CDGN	ACTIVE	HVSSOP	DGN	8	80	RoHS & Green	NIPDAU	Level-1-260C-UNLIM	0 to 70	AQD	Samples
THS4151ID	ACTIVE	SOIC	D	8	75	RoHS & Green	NIPDAU	Level-1-260C-UNLIM	-40 to 85	4151I	Samples
THS4151IDGK	ACTIVE	VSSOP	DGK	8	80	RoHS & Green	NIPDAU	Level-1-260C-UNLIM	-40 to 85	ASU	Samples
THS4151IDGN	ACTIVE	HVSSOP	DGN	8	80	RoHS & Green	NIPDAU	Level-1-260C-UNLIM	-40 to 85	AQE	Samples
THS4151IDGNG4	ACTIVE	HVSSOP	DGN	8	80	TBD	Call TI	Call TI	-40 to 85		Samples
THS4151IDGNR	ACTIVE	HVSSOP	DGN	8	2500	RoHS & Green	NIPDAU	Level-1-260C-UNLIM	-40 to 85	AQE	Samples

(1) The marketing status values are defined as follows:

ACTIVE: Product device recommended for new designs.

LIFEBUY: TI has announced that the device will be discontinued, and a lifetime-buy period is in effect.

NRND: Not recommended for new designs. Device is in production to support existing customers, but TI does not recommend using this part in a new design.

PREVIEW: Device has been announced but is not in production. Samples may or may not be available.

OBSOLETE: TI has discontinued the production of the device.

(2) **RoHS:** TI defines "RoHS" to mean semiconductor products that are compliant with the current EU RoHS requirements for all 10 RoHS substances, including the requirement that RoHS substance do not exceed 0.1% by weight in homogeneous materials. Where designed to be soldered at high temperatures, "RoHS" products are suitable for use in specified lead-free processes. TI may reference these types of products as "Pb-Free".

RoHS Exempt: TI defines "RoHS Exempt" to mean products that contain lead but are compliant with EU RoHS pursuant to a specific EU RoHS exemption.

Green: TI defines "Green" to mean the content of Chlorine (Cl) and Bromine (Br) based flame retardants meet JS709B low halogen requirements of ≤ 1000 ppm threshold. Antimony trioxide based flame retardants must also meet the ≤ 1000 ppm threshold requirement.

(3) MSL, Peak Temp. - The Moisture Sensitivity Level rating according to the JEDEC industry standard classifications, and peak solder temperature.

(4) There may be additional marking, which relates to the logo, the lot trace code information, or the environmental category on the device.

(5) Multiple Device Markings will be inside parentheses. Only one Device Marking contained in parentheses and separated by a "~" will appear on a device. If a line is indented then it is a continuation of the previous line and the two combined represent the entire Device Marking for that device.

(6) Lead finish/Ball material - Orderable Devices may have multiple material finish options. Finish options are separated by a vertical ruled line. Lead finish/Ball material values may wrap to two lines if the finish value exceeds the maximum column width.

Important Information and Disclaimer: The information provided on this page represents TI's knowledge and belief as of the date that it is provided. TI bases its knowledge and belief on information provided by third parties, and makes no representation or warranty as to the accuracy of such information. Efforts are underway to better integrate information from third parties. TI has taken and continues to take reasonable steps to provide representative and accurate information but may not have conducted destructive testing or chemical analysis on incoming materials and chemicals. TI and TI suppliers consider certain information to be proprietary, and thus CAS numbers and other limited information may not be available for release.

In no event shall TI's liability arising out of such information exceed the total purchase price of the TI part(s) at issue in this document sold by TI to Customer on an annual basis.

TAPE AND REEL INFORMATION

QUADRANT ASSIGNMENTS FOR PIN 1 ORIENTATION IN TAPE

*All dimensions are nominal

Device	Package Type	Package Drawing	Pins	SPQ	Reel Diameter (mm)	Reel Width W1 (mm)	A0 (mm)	B0 (mm)	K0 (mm)	P1 (mm)	W (mm)	Pin1 Quadrant
THS4150CDGNR	HVSSOP	DGN	8	2500	330.0	12.4	5.3	3.4	1.4	8.0	12.0	Q1
THS4150CDR	SOIC	D	8	2500	330.0	12.4	6.4	5.2	2.1	8.0	12.0	Q1
THS4150IDGNR	HVSSOP	DGN	8	2500	330.0	12.4	5.3	3.4	1.4	8.0	12.0	Q1
THS4151IDGNR	HVSSOP	DGN	8	2500	330.0	12.4	5.3	3.4	1.4	8.0	12.0	Q1

TAPE AND REEL BOX DIMENSIONS

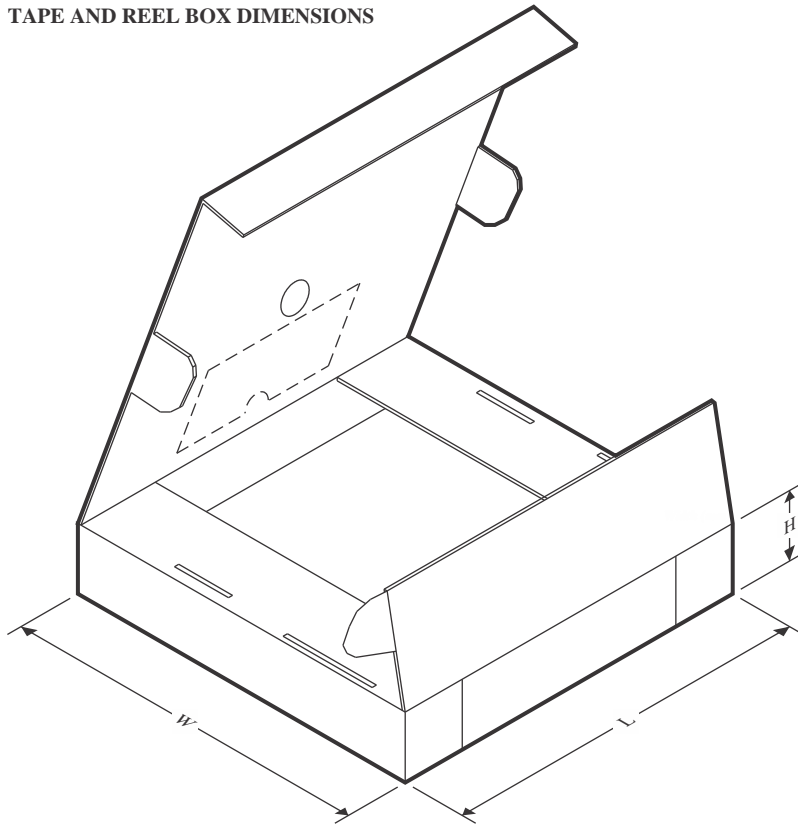

*All dimensions are nominal

Device	Package Type	Package Drawing	Pins	SPQ	Length (mm)	Width (mm)	Height (mm)
THS4150CDGNR	HVSSOP	DGN	8	2500	358.0	335.0	35.0
THS4150CDR	SOIC	D	8	2500	350.0	350.0	43.0
THS4150IDGNR	HVSSOP	DGN	8	2500	358.0	335.0	35.0
THS4151IDGNR	HVSSOP	DGN	8	2500	358.0	335.0	35.0

TUBE

*All dimensions are nominal

Device	Package Name	Package Type	Pins	SPQ	L (mm)	W (mm)	T (μm)	B (mm)
THS4150CD	D	SOIC	8	75	505.46	6.76	3810	4
THS4150ID	D	SOIC	8	75	505.46	6.76	3810	4
THS4151CD	D	SOIC	8	75	505.46	6.76	3810	4
THS4151ID	D	SOIC	8	75	505.46	6.76	3810	4

GENERIC PACKAGE VIEW

DGN 8

PowerPAD VSSOP - 1.1 mm max height

3 x 3, 0.65 mm pitch

SMALL OUTLINE PACKAGE

This image is a representation of the package family, actual package may vary.
Refer to the product data sheet for package details.

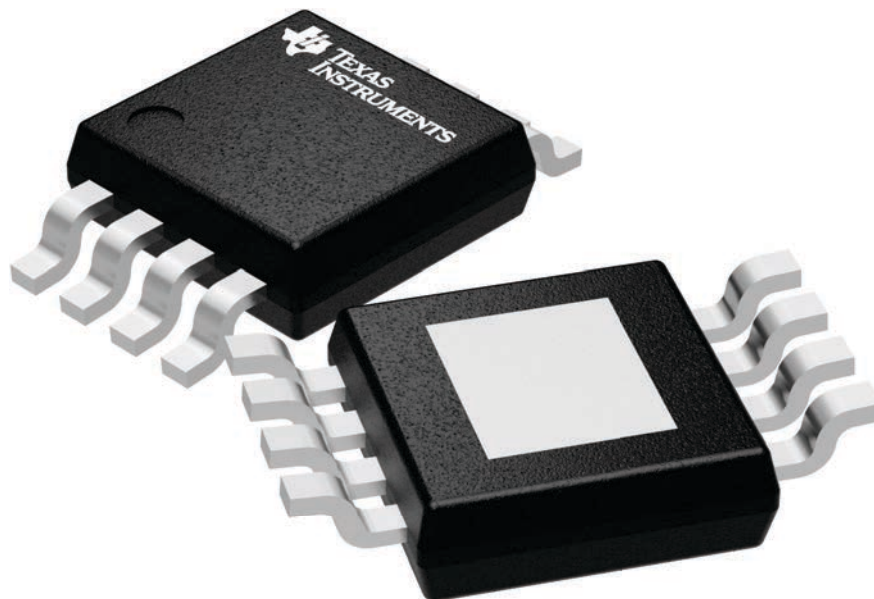

4225482/A



4225481/A 11/2019

PowerPAD is a trademark of Texas Instruments.

NOTES:

1. All linear dimensions are in millimeters. Any dimensions in parenthesis are for reference only. Dimensioning and tolerancing per ASME Y14.5M.
2. This drawing is subject to change without notice.
3. This dimension does not include mold flash, protrusions, or gate burrs. Mold flash, protrusions, or gate burrs shall not exceed 0.15 mm per side.
4. This dimension does not include interlead flash. Interlead flash shall not exceed 0.25 mm per side.
5. Reference JEDEC registration MO-187.

EXAMPLE BOARD LAYOUT

DGN0008D

PowerPAD™ VSSOP - 1.1 mm max height

SMALL OUTLINE PACKAGE



LAND PATTERN EXAMPLE
EXPOSED METAL SHOWN
SCALE: 15X

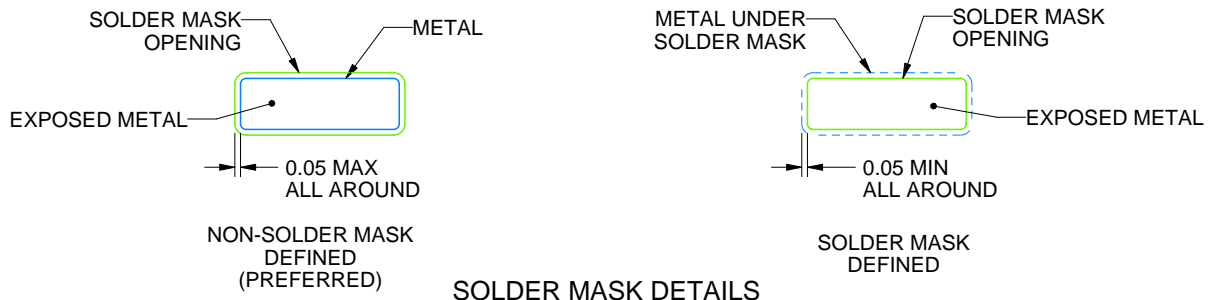

SOLDER MASK DETAILS

4225481/A 11/2019

NOTES: (continued)

6. Publication IPC-7351 may have alternate designs.
7. Solder mask tolerances between and around signal pads can vary based on board fabrication site.
8. Vias are optional depending on application, refer to device data sheet. If any vias are implemented, refer to their locations shown on this view. It is recommended that vias under paste be filled, plugged or tented.
9. Size of metal pad may vary due to creepage requirement.

EXAMPLE STENCIL DESIGN

DGN0008D

PowerPAD™ VSSOP - 1.1 mm max height

SMALL OUTLINE PACKAGE

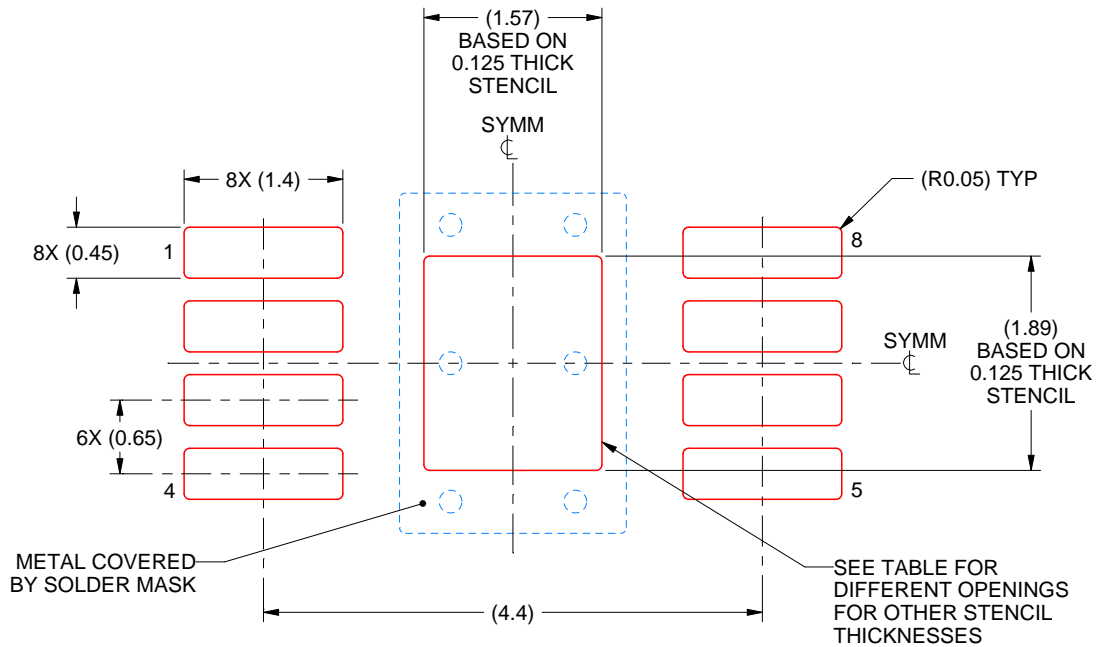

SOLDER PASTE EXAMPLE
EXPOSED PAD 9:
100% PRINTED SOLDER COVERAGE BY AREA
SCALE: 15X

STENCIL THICKNESS	SOLDER STENCIL OPENING
0.1	1.76 X 2.11
0.125	1.57 X 1.89 (SHOWN)
0.15	1.43 X 1.73
0.175	1.33 X 1.60

4225481/A 11/2019

NOTES: (continued)

10. Laser cutting apertures with trapezoidal walls and rounded corners may offer better paste release. IPC-7525 may have alternate design recommendations.
11. Board assembly site may have different recommendations for stencil design.



D0008A

PACKAGE OUTLINE

SOIC - 1.75 mm max height

SMALL OUTLINE INTEGRATED CIRCUIT



4214825/C 02/2019

NOTES:

- Linear dimensions are in inches [millimeters]. Dimensions in parenthesis are for reference only. Controlling dimensions are in inches. Dimensioning and tolerancing per ASME Y14.5M.
- This drawing is subject to change without notice.
- This dimension does not include mold flash, protrusions, or gate burrs. Mold flash, protrusions, or gate burrs shall not exceed $.006$ [0.15] per side.
- This dimension does not include interlead flash.
- Reference JEDEC registration MS-012, variation AA.

EXAMPLE BOARD LAYOUT

D0008A

SOIC - 1.75 mm max height

SMALL OUTLINE INTEGRATED CIRCUIT



LAND PATTERN EXAMPLE
EXPOSED METAL SHOWN
SCALE:8X



SOLDER MASK DETAILS

4214825/C 02/2019

NOTES: (continued)

6. Publication IPC-7351 may have alternate designs.

7. Solder mask tolerances between and around signal pads can vary based on board fabrication site.

EXAMPLE STENCIL DESIGN

D0008A

SOIC - 1.75 mm max height

SMALL OUTLINE INTEGRATED CIRCUIT



SOLDER PASTE EXAMPLE
BASED ON .005 INCH [0.125 MM] THICK STENCIL
SCALE:8X

4214825/C 02/2019

NOTES: (continued)

8. Laser cutting apertures with trapezoidal walls and rounded corners may offer better paste release. IPC-7525 may have alternate design recommendations.
9. Board assembly site may have different recommendations for stencil design.

DGK0008A



PACKAGE OUTLINE

VSSOP - 1.1 mm max height

SMALL OUTLINE PACKAGE



4214862/A 04/2023

NOTES:

PowerPAD is a trademark of Texas Instruments.

1. All linear dimensions are in millimeters. Any dimensions in parenthesis are for reference only. Dimensioning and tolerancing per ASME Y14.5M.
2. This drawing is subject to change without notice.
3. This dimension does not include mold flash, protrusions, or gate burrs. Mold flash, protrusions, or gate burrs shall not exceed 0.15 mm per side.
4. This dimension does not include interlead flash. Interlead flash shall not exceed 0.25 mm per side.
5. Reference JEDEC registration MO-187.

EXAMPLE BOARD LAYOUT

DGK0008A

™ VSSOP - 1.1 mm max height

SMALL OUTLINE PACKAGE



LAND PATTERN EXAMPLE
EXPOSED METAL SHOWN
SCALE: 15X



SOLDER MASK DETAILS

4214862/A 04/2023

NOTES: (continued)

6. Publication IPC-7351 may have alternate designs.
7. Solder mask tolerances between and around signal pads can vary based on board fabrication site.
8. Vias are optional depending on application, refer to device data sheet. If any vias are implemented, refer to their locations shown on this view. It is recommended that vias under paste be filled, plugged or tented.
9. Size of metal pad may vary due to creepage requirement.

EXAMPLE STENCIL DESIGN

DGK0008A

™ VSSOP - 1.1 mm max height

SMALL OUTLINE PACKAGE



SOLDER PASTE EXAMPLE
SCALE: 15X

4214862/A 04/2023

NOTES: (continued)

11. Laser cutting apertures with trapezoidal walls and rounded corners may offer better paste release. IPC-7525 may have alternate design recommendations.
12. Board assembly site may have different recommendations for stencil design.

IMPORTANT NOTICE AND DISCLAIMER

TI PROVIDES TECHNICAL AND RELIABILITY DATA (INCLUDING DATA SHEETS), DESIGN RESOURCES (INCLUDING REFERENCE DESIGNS), APPLICATION OR OTHER DESIGN ADVICE, WEB TOOLS, SAFETY INFORMATION, AND OTHER RESOURCES "AS IS" AND WITH ALL FAULTS, AND DISCLAIMS ALL WARRANTIES, EXPRESS AND IMPLIED, INCLUDING WITHOUT LIMITATION ANY IMPLIED WARRANTIES OF MERCHANTABILITY, FITNESS FOR A PARTICULAR PURPOSE OR NON-INFRINGEMENT OF THIRD PARTY INTELLECTUAL PROPERTY RIGHTS.

These resources are intended for skilled developers designing with TI products. You are solely responsible for (1) selecting the appropriate TI products for your application, (2) designing, validating and testing your application, and (3) ensuring your application meets applicable standards, and any other safety, security, regulatory or other requirements.

These resources are subject to change without notice. TI grants you permission to use these resources only for development of an application that uses the TI products described in the resource. Other reproduction and display of these resources is prohibited. No license is granted to any other TI intellectual property right or to any third party intellectual property right. TI disclaims responsibility for, and you will fully indemnify TI and its representatives against, any claims, damages, costs, losses, and liabilities arising out of your use of these resources.

TI's products are provided subject to [TI's Terms of Sale](#) or other applicable terms available either on [ti.com](https://www.ti.com) or provided in conjunction with such TI products. TI's provision of these resources does not expand or otherwise alter TI's applicable warranties or warranty disclaimers for TI products.

TI objects to and rejects any additional or different terms you may have proposed.

Mailing Address: Texas Instruments, Post Office Box 655303, Dallas, Texas 75265
Copyright © 2024, Texas Instruments Incorporated

Looking for pricing, stock, or lifecycle information?

Click below to explore more details on WIN SOURCE:

 [View THS4151IDGK on WIN SOURCE](#)

 [Texas Instruments](#) Information

Optimize Your Supply Chain with WIN SOURCE Solutions

-  Global Sourcing Solution
-  Obsolete Management
-  Cost Control Management
-  Shortage Management
-  Alternative Solution
-  Excess Inventory Management