



THE DATASHEET OF SX28AC/SS





SX20AC/SX28AC

Configurable Communications Controllers with EE/Flash Program Memory, In-System Programming Capability and On-Chip Debug

1.0 PRODUCT OVERVIEW

1.1 Introduction

The Ubicom SX family of configurable communications controllers are fabricated in an advanced CMOS process technology. The advanced process, combined with a RISC-based architecture, allows high-speed computation, flexible I/O control, and efficient data manipulation. Throughput is enhanced by operating the device at frequencies up to 75 MHz and by optimizing the instruction set to include mostly single-cycle instructions. In addition, the SX architecture is deterministic and totally reprogrammable. The unique combination of these characteristics

enables the device to implement hard real-time functions as software modules (Virtual Peripheral™) to replace traditional hardware functions.

On-chip functions include a general-purpose 8-bit timer with prescaler, an analog comparator, a brown-out detector, a watchdog timer, a power-save mode with multi-source wakeup capability, an internal R/C oscillator, user-selectable clock modes, and high-current outputs.

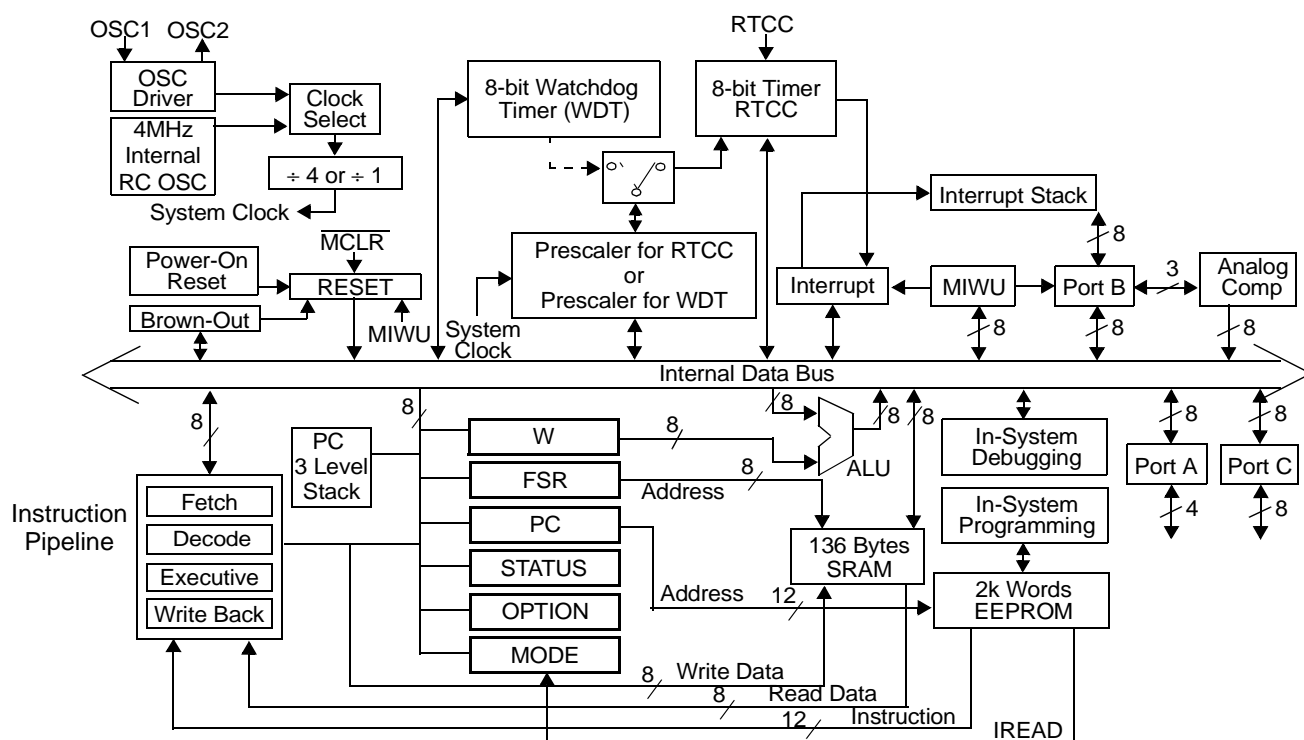

Figure 1-1. Block Diagram

Table of Contents

1.0	Product Overview	1	10.0	Real Time Clock (RTCC)/Watchdog Timer	23
1.1	Introduction	1	10.1	RTCC	23
1.2	Key Features	3	10.2	Watchdog Timer	23
1.3	Architecture	4	10.3	The Prescaler	24
1.3.1	The Virtual Peripheral Concept	4	11.0	Comparator	25
1.3.2	The Communications Controller	4	12.0	Reset	27
1.4	Programming and Debugging Support	4	13.0	Brown-Out Detector	28
1.5	Applications	4	14.0	Register States Upon Different reset operations	29
2.0	Connection Diagrams	5	15.0	Instruction Set	30
2.1	Pin Assignments	5	15.1	Instruction Set Features	30
2.2	Pin Descriptions	5	15.2	Instruction Execution	30
2.3	Part Numbering	6	15.3	Addressing Modes	30
3.0	Port Descriptions	7	15.4	RAM Addressing	31
3.1	Reading and Writing the Ports	7	15.5	The Bank Instruction	31
3.1.1	Read-Modify-Write Considerations	9	15.6	Bit Manipulation	31
3.2	Port Configuration	9	15.7	Input/Output Operation	31
3.2.1	MODE Register	9	15.8	Increment/Decrement	31
3.2.2	Port Configuration Registers	9	15.9	Loop Counting and Data Pointing Testing	31
3.2.3	Port Configuration Upon Reset	10	15.10	Branch and Loop Call Instructions	31
4.0	Special-Function Registers	11	15.10.1	Jump Operation	31
4.1	PC Register (02h)	11	15.10.2	Page Jump Operation	32
4.2	STATUS Register (03h)	11	15.10.3	Call Operation	32
4.3	OPTION Register	12	15.10.4	Page Call Operation	32
5.0	Device Configuration Registers	13	15.11	Return Instructions	32
5.1	FUSE Word (Read/Program at FFFh in main memory map)	13	15.12	Subroutine Operation	33
5.2	FUSEX Word (Read/Program via Programming Command)	14	15.12.1	Push Operation	33
5.3	DEVICE Word (Hard-Wired Read-Only)	14	15.12.2	Pop Operation	33
6.0	Memory Organization	15	15.13	Comparison and Conditional Branch Instructions	34
6.1	Program Memory	15	15.14	Logical Instruction	34
6.1.1	Program Counter	15	15.15	Shift and Rotate Instructions	34
6.1.2	Subroutine Stack	15	15.16	Complement and SWAP	34
6.2	Data Memory	15	15.17	Key to Abbreviations and Symbols	34
6.2.1	File Select Register (04h)	15	16.0	Instruction Set Summary Table	35
7.0	Power Down Mode	17	16.1	Equivalent Assembler Mnemonics	38
7.1	Multi-Input Wakeup	17	17.0	Electrical Characteristics	39
7.2	Port B MIWU/Interrupt Configuration	18	17.1	Absolute Maximum Ratings	39
8.0	Interrupt Support	19	17.2	DC Characteristics	40
9.0	Oscillator Circuits	21	17.3	AC Characteristics	41
9.1	XT, LP or HS modes	21	17.4	Comparator DC and AC Specifications	41
9.2	External RC Mode	23	17.5	Typical Performance Characteristics	42
9.3	Internal RC Mode	23	18.0	Package Dimensions	45

1.2 Key Features

50 MIPS Performance

- SX20AC/SX28AC: DC - 75 MHz
- SX20AC/SX28AC: 13.3 ns instruction cycle, 39.9 ns internal interrupt response
- 1 instruction per clock (branches 3)

EE/FLASH Program Memory and SRAM Data Memory

- Access time of < 13.3 ns provides single cycle access
- EE/Flash rated for > 10,000 rewrite cycles
- 2048 Words EE/Flash program memory
- 136x8 bits SRAM data memory

CPU Features

- Compact instruction set
- All instructions are single cycle except branch
- Eight-level push/pop hardware stack for subroutine linkage
- Fast table lookup capability through run-time readable code (IREAD instruction)
- Totally predictable program execution flow for hard real-time applications

Fast and Deterministic Interrupt

- Jitter-free 3-cycle internal interrupt response
- Hardware context save/restore of key resources such as PC, W, STATUS, and FSR within the 3-cycle interrupt response time
- External wakeup/interrupt capability on Port B (8 pins)

Flexible I/O

- All pins individually programmable as I/O
- Inputs are TTL or CMOS level selectable
- All pins have selectable internal pull-ups
- Selectable Schmitt Trigger inputs on Ports B, and C
- All outputs capable of sourcing/sinking 30 mA
- Port A outputs have symmetrical drive
- Analog comparator support on Port B (RB0 OUT, RB1 IN-, RB2 IN+)
- Selectable I/O operation synchronous to the oscillator clock

Hardware Peripheral Features

- One 8-bit Real Time Clock/Counter (RTCC) with programmable 8-bit prescaler
- Watchdog Timer (shares the RTCC prescaler)
- Analog comparator
- Brown-out detector
- Multi-Input Wakeup logic on 8 pins
- Internal RC oscillator with configurable rate from 31.25 kHz to 4 MHz
- Power-On-Reset

Packages

- 20-pin SSOP, 28-pin DIP/SSOP

Programming and Debugging Support

- On-chip in-system programming support with serial and parallel interfaces
- In-system serial programming via oscillator pins
- On-chip in-System debugging support logic
- Real-time emulation, full program debug, and integrated development environment offered by third party tool vendors

1.3 Architecture

The SX devices use a modified Harvard architecture. This architecture uses two separate memories with separate address buses, one for the program and one for data, while allowing transfer of data from program memory to SRAM. This ability allows accessing data tables from program memory. The advantage of this architecture is that instruction fetch and memory transfers can be overlapped with a multi-stage pipeline, which means the next instruction can be fetched from program memory while the current instruction is being executed using data from the data memory.

Ubicom has developed a revolutionary RISC-based architecture and memory design techniques that is 20 times faster than conventional MCUs, deterministic, jitter free, and totally reprogrammable.

The SX family implements a four-stage pipeline (fetch, decode, execute, and write back), which results in execution of one instruction per clock cycle. For example, at the maximum operating frequency of 75 MHz, instructions are executed at the rate of one per 13.3ns clock cycle.

1.3.1 The Virtual Peripheral Concept

Virtual Peripheral concept enables the “software system on a chip” approach. Virtual Peripheral, a software module that replaces a traditional hardware peripheral, takes advantage of the Ubicom architecture’s high performance and deterministic nature to produce same results as the hardware peripheral with much greater flexibility.

The speed and flexibility of the Ubicom architecture complemented with the availability of the Virtual Peripheral library, simultaneously address a wide range of engineering and product development concerns. They decrease the product development cycle dramatically, shortening time to production to as little as a few days.

Ubicom’s time-saving Virtual Peripheral library gives the system designers a choice of ready-made solutions, or a head start on developing their own peripherals. So, with Virtual Peripheral modules handling established functions, design engineers can concentrate on adding value to other areas of the application.

The concept of Virtual Peripheral combined with in-system re-programmability provides a power development platform ideal for the communications industry because of the numerous and rapidly evolving standards and protocols.

Overall, the concept of Virtual Peripheral provides benefits such as using a more simple device, reduced component count, fast time to market, increased flexibility in design, customization to your application, and ultimately overall system cost reduction.

Some examples of Virtual Peripheral modules are:

- Communication interfaces such as I²C™, Microwire™ (μ-Wire), SPI, IrDA Stack, UART, and Modem functions
- Frequency generation and measurement
- PPM/PWM output

- Delta/Sigma ADC
- DTMF generation/detection
- PSK/FSK generation/detection
- FFT/DFT based algorithms

1.3.2 The Communications Controller

The combination of the Ubicom hardware architecture and the Virtual Peripheral concept create a powerful, creative platform for the communications design communities: SX communications controller. Its high processing power, reconfigurability, cost-effectiveness, and overall design freedom give the designer the power to build products for the future with the confidence of knowing that they can keep up with innovation in standards and other areas.

1.4 Programming and Debugging Support

The SX devices are currently supported by third party tool vendors. On-chip in-system debug capabilities have been added, allowing tools to provide an integrated development environment including editor, macro assembler, debugger, and programmer. Un-obtrusive in-system programming is provided through the OSC pins. There is no need for a bon-out chip, so the user does not have to worry about the potential variations in electrical characteristics of a bond-out chip and the actual chip used in the target applications. The user can test and revise the fully debugged code in the actual SX, in the actual application, and get to production much faster.

1.5 Applications

Emerging applications and advances in existing ones require higher performance while maintaining low cost and fast time-to-production.

The device provides solutions for many familiar applications such as process controllers, electronic appliances/tools, security/monitoring systems, consumer automotive, sound generation, motor control, and personal communication devices. In addition, the device is suitable for applications that require DSP-like capabilities, such as closed-loop servo control (digital filters), digital answering machines, voice notation, interactive toys, and magnetic-stripe readers.

Furthermore, the growing Virtual Peripheral library features new components, such as the Internet Protocol stack, and communication interfaces, that allow design engineers to embed Internet connectivity into all of their products at extremely low cost and very little effort.

2.0 CONNECTION DIAGRAMS

2.1 Pin Assignments

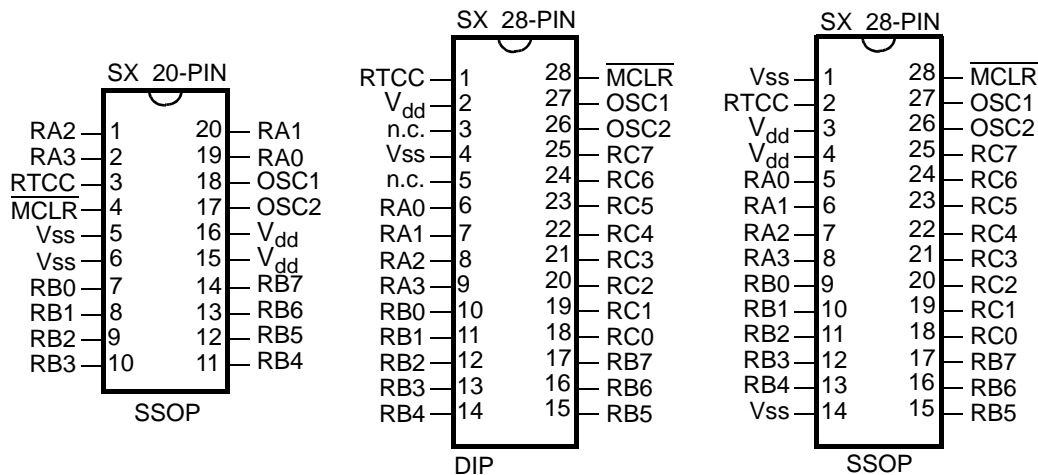

2.2 Pin Descriptions

Name	Pin Type	Input Levels	Description
RA0	I/O	TTL/CMOS	Bidirectional I/O Pin; symmetrical source / sink capability
RA1	I/O	TTL/CMOS	Bidirectional I/O Pin; symmetrical source / sink capability
RA2	I/O	TTL/CMOS	Bidirectional I/O Pin; symmetrical source / sink capability
RA3	I/O	TTL/CMOS	Bidirectional I/O Pin; symmetrical source / sink capability
RB0	I/O	TTL/CMOS/ST	Bidirectional I/O Pin; comparator output; MIWU/Interrupt input
RB1	I/O	TTL/CMOS/ST	Bidirectional I/O Pin; comparator negative input; MIWU/Interrupt input
RB2	I/O	TTL/CMOS/ST	Bidirectional I/O Pin; comparator positive input; MIWU/Interrupt input
RB3	I/O	TTL/CMOS/ST	Bidirectional I/O Pin; MIWU/Interrupt input
RB4	I/O	TTL/CMOS/ST	Bidirectional I/O Pin; MIWU/Interrupt input
RB5	I/O	TTL/CMOS/ST	Bidirectional I/O Pin; MIWU/Interrupt input
RB6	I/O	TTL/CMOS/ST	Bidirectional I/O Pin; MIWU/Interrupt input
RB7	I/O	TTL/CMOS/ST	Bidirectional I/O Pin; MIWU/Interrupt input
RC0	I/O	TTL/CMOS/ST	Bidirectional I/O pin
RC1	I/O	TTL/CMOS/ST	Bidirectional I/O pin
RC2	I/O	TTL/CMOS/ST	Bidirectional I/O pin
RC3	I/O	TTL/CMOS/ST	Bidirectional I/O pin
RC4	I/O	TTL/CMOS/ST	Bidirectional I/O pin
RC5	I/O	TTL/CMOS/ST	Bidirectional I/O pin
RC6	I/O	TTL/CMOS/ST	Bidirectional I/O pin
RC7	I/O	TTL/CMOS/ST	Bidirectional I/O pin
RTCC	I	ST	Input to Real-Time Clock/Counter
MCLR	I	ST	Master Clear reset input – active low
OSC1/In/V _{pp}	I	ST	Crystal oscillator input – external clock source input
OSC2/Out	O	CMOS	Crystal oscillator output – in R/C mode, internally pulled to V _{dd} through weak pull-up
V _{dd}	P	–	Positive supply pin
V _{ss}	P	–	Ground pin

Note: I = input, O = output, I/O = Input/Output, P = Power, TTL = TTL input, CMOS = CMOS input, ST = Schmitt Trigger input, MIWU = Multi-Input Wakeup input

2.3 Part Numbering

Table 2-1. Ordering Information

Device	Pins	I/O	Operating Frequency (MHz)	EE/Flash (Words)	RAM (Bytes)	Operating Temp. (°C)
SX20AC/SS	20	12	50	2K	136	-40°C to +85°C
SX20AC/SS	20	12	75	2K	136	0°C to +70°C
SX28AC/DP	28	20	50	2K	136	-40°C to +85°C
SX28AC/DP	28	20	75	2K	136	0°C to +70°C
SX28AC/SS	28	20	50	2K	136	-40°C to +85°C
SX28AC/SS	28	20	75	2K	136	0°C to +70°C

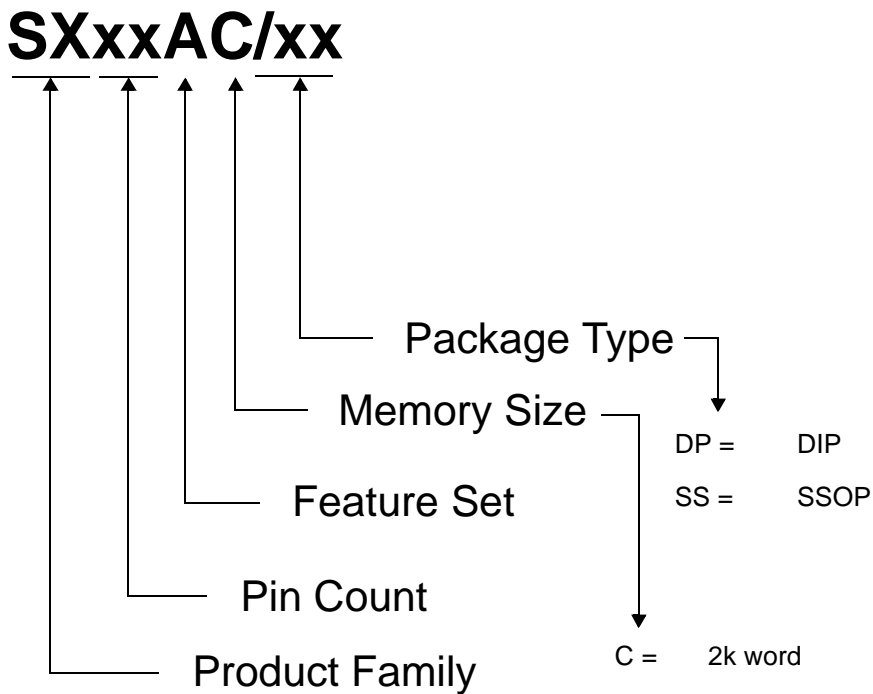

Figure 2-1. Part Number Reference Guide

3.0 PORT DESCRIPTIONS

The device contains a 4-bit I/O port (Port A) and two 8-bit I/O ports (Port B, Port C). Port A provides symmetrical drive capability. Each port has three associated 8-bit registers (Direction, Data, TTL/CMOS Select, and Pull-Up Enable) to configure each port pin as Hi-Z input or output, to select TTL or CMOS voltage levels, and to enable/disable the weak pull-up resistor. The upper four bits of the registers associated with Port A are not used. The least significant bit of the registers corresponds to the least significant port pin. To access these registers, an appropriate value must be written into the MODE register.

Upon power-up, all bits in these registers are initialized to "1".

The associated registers allow for each port bit to be individually configured under software control as shown below:

Table 3-1. Port Configuration

Data Direction Registers: RA, RB, RC		TTL/CMOS Select Registers: LVL_A, LVL_B, LVL_C		Pullup Enable Registers: PLP_A, PLP_B, PLP_C	
0	1	0	1	0	1
Output	Hi-Z Input	CMOS	TTL	Enable	Disable

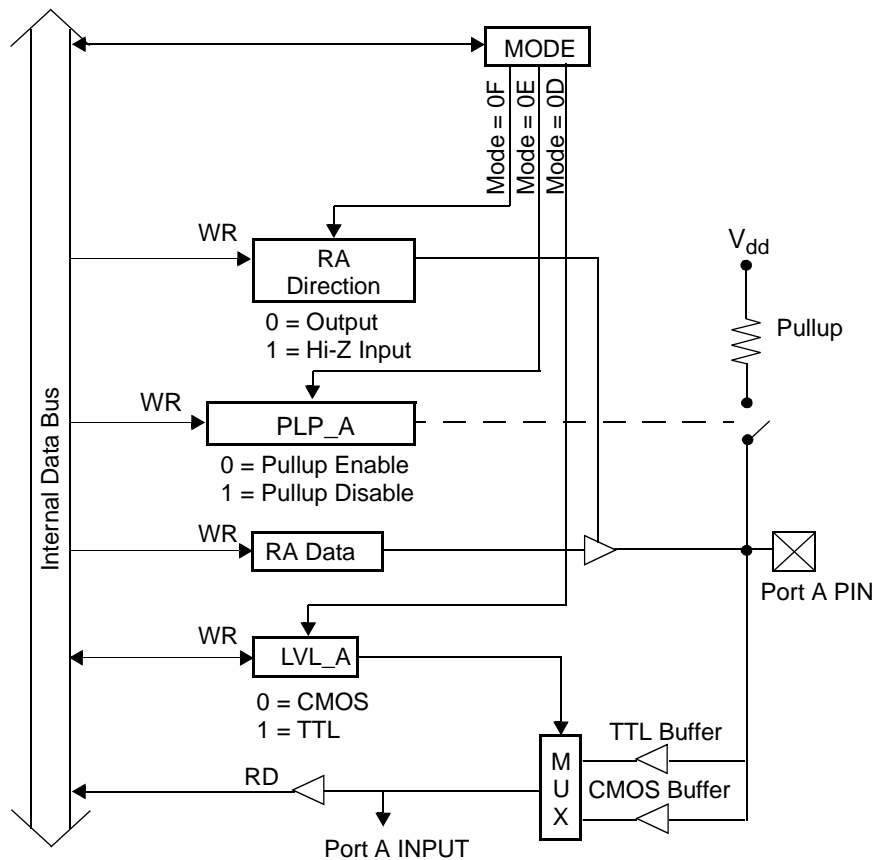

Figure 3-1. Port A Configuration

3.1 Reading and Writing the Ports

The three ports are memory-mapped into the data memory address space. To the CPU, the three ports are available as the RA, RB, and RC file registers at data memory addresses 05h, 06h, and 07h, respectively.

Writing to a port data register sets the voltage levels of the corresponding port pins that have been configured to operate as outputs. Reading from a register reads the voltage levels of the corresponding port pins that have been configured as inputs.

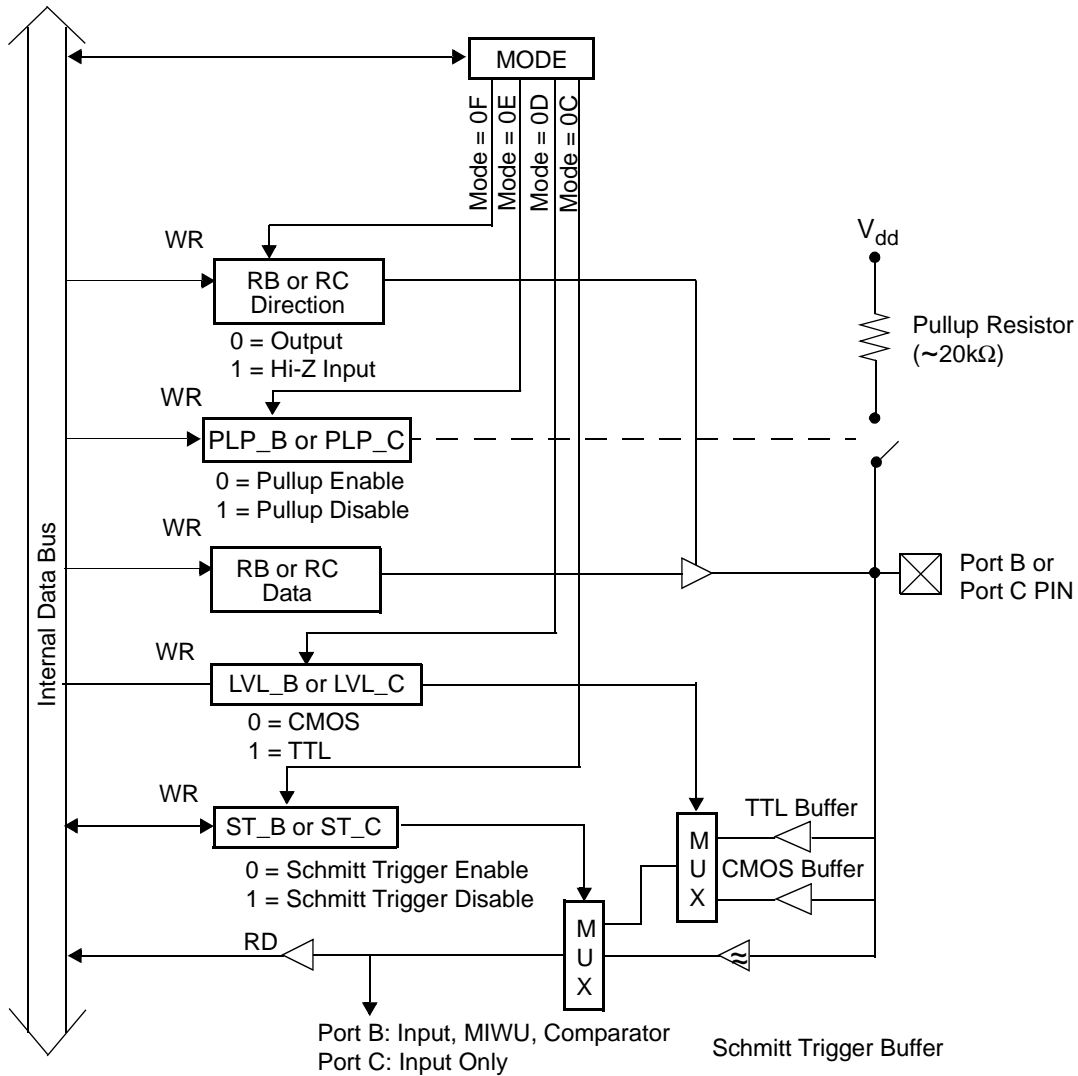

Figure 3-2. Port B, Port C Configuration

For example, suppose all four Port A pins are configured as outputs and with RA0 and RA1 to be high, and RA2 and RA3 to be low:

```

mov  W,#$03    ;load W with the value 03h
                ;(bits 0 and 1 high)
mov  $05,W     ;write 03h to Port A data
                ;register
    
```

The second “mov” instruction in this example writes the Port A data register (RA), which controls the output levels of the four Port A pins, RA0 through RA3. Because Port A has only four I/O pins, only the four least significant bits of this register are used. The four high-order register bits are “don’t care” bits. Port B and Port C are both eight bits wide, so the full widths of the RB and RC registers are used.

When a write is performed to a bit position for a port that has been configured as an input, a write to the port data register is still performed, but it has no immediate effect on the pin. If later that pin is configured to operate as an output, it will reflect the value that has been written to the data register.

When a read is performed from a bit position for a port, the operation is actually reading the voltage level on the pin itself, not necessarily the bit value stored in the port data register. This is true whether the pin is configured to operate as an input or an output. Therefore, with the pin configured to operate as an input, the data register contents have no effect on the value that you read. With the pin configured to operate as an output, what is read generally matches what has been written to the register.

3.1.1 Read-Modify-Write Considerations

Caution must be exercised when performing two successive read-modify-write instructions (SETB or CLR B operations) on I/O port pin. Input data used for an instruction must be valid *during* the time the instruction is executed, and the output result from an instruction is valid only *after* that instruction completes its operation. Unexpected results from successive read-modify-write operations on I/O pins can occur when the device is running at high speeds. Although the device has an internal write-back section to prevent such conditions, it is still recommended that the user program include a NOP instruction as a buffer between successive read-modify-write instructions performed on I/O pins of the same port.

Also note that reading an I/O port is actually reading the pins, not the output data latches. That is, if the pin output driver is enabled and driven high while the pin is held low externally, the port pin will read low.

3.2 Port Configuration

Each port pin offers the following configuration options:

- data direction
- input voltage levels (TTL or CMOS)
- pullup type (pullup resistor enable or disable)
- Schmitt trigger input (for Port B and Port C only)

Port B offers the additional option to use the port pins for the Multi-Input Wakeup/Interrupt function and/or the analog comparator function.

Port configuration is performed by writing to a set of control registers associated with the port. A special-purpose instruction is used to write these control registers:

- `mov !RA,W` (move W to Port A control register)
- `mov !RB,W` (move W to Port B control register)
- `mov !RC,W` (move W to Port C control register)

Each one of these instructions writes a port control register for Port A, Port B, or Port C. There are multiple control registers for each port. To specify which one you want to access, you use another register called the MODE register.

3.2.1 MODE Register

The MODE register controls access to the port configuration registers. Because the MODE register is not memory-mapped, it is accessed by the following special-purpose instructions:

- `mov M, #lit` (move literal to MODE register)
- `mov M,W` (move W to MODE register)
- `mov W,M` (move MODE register to W)

The value contained in the MODE register determines which port control register is accessed by the “`mov !rx,W`” instruction as indicated in Table 3-3. MODE register values not listed in the table are reserved for future expansion and should not be used. Therefore, the MODE register should always contain a value from 08h to 0Fh. Upon reset, the MODE register is initialized to 0Fh, which enables access to the port direction registers.

After a value is written to the MODE register, that setting remains in effect until it is changed by writing to the MODE register again. For example, you can write the value 0Eh to the MODE register just once, and then write to each of the three pullup configuration registers using the three “`mov !rx,W`” instructions.

Table 3-3. MODE Register and Port Control Register Access

MODE Reg.	<code>mov !RA,W</code>	<code>mov !RB,W</code>	<code>mov !RC,W</code>
08h	not used	CMP_B	not used
09h	not used	WKPND_B	not used
0Ah	not used	WKED_B	not used
0Bh	not used	WKEN_B	not used
0Ch	not used	ST_B	ST_C
0Dh	LVL_A	LVL_B	LVL_C
0Eh	PLP_A	PLP_B	PLP_C
0Fh	RA Direction	RB Direction	RC Direction

The following code example shows how to program the pullup control registers.

```

mov M, #0Eh ;MODE=0Eh to access port pullup
              ;registers

mov W, #03h ;W = 0000 0011
mov !RA,W   ;disable pullups for A0 and A1

mov W, #FFh ;W = 1111 1111
mov !RB,W   ;disable all pullups for B0-B7

mov W, #00h ;W = 0000 0000
mov !RC,W   ;enable all pullups for C0-C7

```

First the MODE register is loaded with 0Eh to select access to the pullup control registers (PLP_A, PLP_B, and PLP_C). Then the MOV !rx,W instructions are used to specify which port pins are to be connected to the internal pullup resistors. Setting a bit to 1 disconnects the corresponding pullup resistor, and clearing a bit to 0 connects the corresponding pullup resistor.

3.2.2 Port Configuration Registers

The port configuration registers that you control with the MOV !rx,W instruction operate as described below.

RA, RB, and RC Data Direction Registers (MODE=0Fh)

Each register bit sets the data direction for one port pin. Set the bit to 1 to make the pin operate as a high-impedance input. Clear the bit to 0 to make the pin operate as an output.

PLP_A, PLP_B, and PLP_C: Pullup Enable Registers (MODE=0Eh)

Each register bit determines whether an internal pullup resistor is connected to the pin. Set the bit to 1 to disconnect the pullup resistor or clear the bit to 0 to connect the pullup resistor.

LVL_A, LVL_B, and LVL_C: Input Level Registers (MODE=0Dh)

Each register bit determines the voltage levels sensed on the input port, either TTL or CMOS, when the Schmitt trigger option is disabled. Program each bit according to the type of device that is driving the port input pin. Set the bit to 1 for TTL or clear the bit to 0 for CMOS.

ST_B and ST_C: Schmitt Trigger Enable Registers (MODE=0Ch)

Each register bit determines whether the port input pin operates with a Schmitt trigger. Set the bit to 1 to disable Schmitt trigger operation and sense either TTL or CMOS voltage levels; or clear the bit to 0 to enable Schmitt trigger operation.

WKEN_B: Wakeup Enable Register (MODE=0Bh)

Each register bit enables or disables the Multi-Input Wakeup/Interrupt (MIWU) function for the corresponding Port B input pin. Clear the bit to 0 to enable MIWU operation or set the bit to 1 to disable MIWU operation. For more information on using the Multi-Input Wakeup/Interrupt function, see Section 7.0.

WKED_B: Wakeup Edge Register (MODE=0Ah)

Each register bit selects the edge sensitivity of the Port B input pin for MIWU operation. Clear the bit to 0 to sense rising (low-to-high) edges. Set the bit to 1 to sense falling (high-to-low) edges.

WKPND_B: Wakeup Pending Bit Register (MODE=09h)

When you access the WKPND_B register using MOV !RB,W, the CPU does an exchange between the contents of W and WKPND_B. This feature lets you read the WKPND_B register contents. Each bit indicates the status of the corresponding MIWU pin. A bit set to 1 indicates that a valid edge has occurred on the corresponding MIWU pin, triggering a wakeup or interrupt. A bit set to 0 indicates that no valid edge has occurred on the MIWU pin.

CMP_B: Comparator Register (MODE=08h)

When you access the CMP_B register using MOV !RB,W, the CPU does an exchange between the contents of W and CMP_B. This feature lets you read the CMP_B register contents. Clear bit 7 to enable operation of the comparator. Clear bit 6 to place the comparator result on the RB0 pin. Bit 0 is a result bit that is set to 1 when the voltage on RB2 is greater than RB1, or cleared to 0 otherwise. (For more information using the comparator, see Section 11.0.)

3.2.3 Port Configuration Upon Reset

Upon reset, all the port control registers are initialized to FFh. Thus, each pin is configured to operate as a high-impedance input that senses TTL voltage levels, with no internal pullup resistor connected. The MODE register is initialized to 0Fh, which allows immediate access to the data direction registers using the "MOV !rx,W" instruction.

4.0 SPECIAL-FUNCTION REGISTERS

The CPU uses a set of special-function registers to control the operation of the device.

The CPU registers include an 8-bit working register (W), which serves as a pseudo accumulator. It holds the second operand of an instruction, receives the literal in immediate type instructions, and also can be program-selected as the destination register.

A set of 31 file registers serves as the primary accumulator. One of these registers holds the first operand of an instruction and another can be program-selected as the destination register. The first eight file registers include the Real-Time Clock/Counter register (RTCC), the lower eight bits of the 11-bit Program Counter (PC), the 8-bit STATUS register, three port control registers for Port A, Port B, Port C, the 8-bit File Select Register (FSR), and INDF used for indirect addressing.

The five low-order bits of the FSR register select one of the 31 file registers in the indirect addressing mode. Calling for the file register located at address 00h (INDF) in any of the file-oriented instructions selects indirect addressing, which uses the FSR register. It should be noted that the file register at address 00h is not a physically implemented register. The CPU also contains an 8-level, 11-bit hardware push/pop stack for subroutine linkage.

Table 4-1. Special-Function Registers

Addr	Name	Function
00h	INDF	Used for indirect addressing
01h	RTCC	Real Time Clock/Counter
02h	PC	Program Counter (low byte)
03h	STATUS	Holds Status bits of ALU
04h	FSR	File Select Register
05h	RA	Port RA Control register
06h	RB	Port RB Control register
07h	RC*	Port RC Control register

*In the SX18 package, Port C is not used, and address 07h is available as a general-purpose RAM location.

4.1 PC Register (02h)

The PC register holds the lower eight bits of the program counter. It is accessible at run time to perform branch operations.

4.2 STATUS Register (03h)

The STATUS register holds the arithmetic status of the ALU, the page select bits, and the reset state. The STATUS register is accessible during run time, except that bits PD and TO are read-only. It is recommended that only SETB and CLR B instructions be used on this register. Care should be exercised when writing to the STATUS register as the ALU status bits are updated upon completion of the write operation, possibly leaving

the STATUS register with a result that is different than intended.

PA2	PA1	PA0	TO	PD	Z	DC	C
Bit 7				Bit 0			

Bit 7-5: Page select bits PA2:PA0

000 = Page 0 (000h – 01FFh)

001 = Page 1 (200h – 03FFh)

010 = Page 2 (400h – 05FFh)

011 = Page 3 (600h – 07FFh)

Bit 4: Time Out bit, TO

1 = Set to 1 after power up and upon execution of CLRWDT or SLEEP instructions

0 = A watchdog time-out occurred

Bit 3: Power Down bit, PD

1 = Set to a 1 after power up and upon execution of the CLRWDT instruction

0 = Cleared to a '0' upon execution of SLEEP instruction

Bit 2: Zero bit, Z

1 = Result of math operation is zero

0 = Result of math operation is non-zero

Bit 1: Digit Carry bit, DC

After Addition:

1 = A carry from bit 3 occurred

0 = No carry from bit 3 occurred

After Subtraction:

1 = No borrow from bit 3 occurred

0 = A borrow from bit 3 occurred

Bit 0: Carry bit, C

After Addition:

1 = A carry from bit 7 of the result occurred

0 = No carry from bit 7 of the result occurred

After Subtraction:

1 = No borrow from bit 7 of the result occurred

0 = A borrow from bit 7 of the result occurred

Rotate (RR or RL) Instructions:

The carry bit is loaded with the low or high order bit, respectively. When CF bit is cleared, Carry bit works as input for ADD and SUB instructions.

4.3 OPTION Register

RTW	RTE _IE	RTS	RTE _ES	PSA	PS2	PS1	PS0
Bit 7			Bit 0				

When the OPTIONX bit in the FUSE word is cleared, bits 7 and 6 of the OPTION register function as described below.

When the OPTIONX bit is set, bits 7 and 6 of the OPTION register read as '1's.

- RTW RTCC/W register selection:
0 = Register 01h addresses W
1 = Register 01h addresses RTCC
- RTE_IE RTCC edge interrupt enable:
0 = RTCC roll-over interrupt is enabled
1 = RTCC roll-over interrupt is disabled
- RTS RTCC increment select:
0 = RTCC increments on internal instruction cycle
1 = RTCC increments upon transition on RTCC pin
- RTE_ES RTCC edge select:
0 = RTCC increments on low-to-high transitions
1 = RTCC increments on high-to-low transitions
- PSA Prescaler Assignment:
0 = Prescaler is assigned to RTCC, with divide rate determined by PS0-PS2 bits
1 = Prescaler is assigned to WDT, and divide rate on RTCC is 1:1
- PS2-PS0 Prescaler divider (see Table 4-2)

Table 4-2. Prescaler Divider Ratios

PS2, PS1, PS0	RTCC Divide Rate	Watchdog Timer Divide Rate
000	1:2	1:1
001	1:4	1:2
010	1:8	1:4
011	1:16	1:8
100	1:32	1:16
101	1:64	1:32
110	1:128	1:64
111	1:256	1:128

Upon reset, all bits in the OPTION register are set to 1.

5.0 DEVICE CONFIGURATION REGISTERS

The SX device has three registers (FUSE, FUSEX, DEVICE) that control functions such as operating the device in Turbo mode, extended (8-level deep) stack operation, and speed selection for the internal RC oscillator. These registers are not programmable “on the fly”

during normal device operation. Instead, the FUSE and FUSEX registers can only be accessed when the SX device is being programmed. The DEVICE register is a read-only, hard-wired register, programmed during the manufacturing process.

5.1 FUSE Word (Read/Program at FFFh in main memory map)

$\overline{\text{TURBO}}$	$\overline{\text{SYNC}}$	Reserved	Reserved	$\overline{\text{IRC}}$	$\overline{\text{DIV1/IFBD}}$	$\overline{\text{DIV0/FOSC2}}$	Re-served	$\overline{\text{CP}}$	WDTE	FOSC1	FOSC0
---------------------------	--------------------------	----------	----------	-------------------------	-------------------------------	--------------------------------	-----------	------------------------	------	-------	-------

Bit 11

Bit 0

$\overline{\text{TURBO}}$	Turbo mode enable: 0 = turbo (instruction clock = osc/1) 1 = instr clock = osc/4
$\overline{\text{SYNC}}$	Synchronous input enable (for turbo mode): This bit synchronizes the signal presented at the input pin to the internal clock through two internal flip-flops. 0 = enabled 1 = disabled
$\overline{\text{IRC}}$	Internal RC oscillator enable: 0 = enabled - OSC1 pulled low by weak pullup, OSC2 pulled high by weak pullup 1 = disabled - OSC1 and OSC2 behave according to FOSC2: FOSC0
DIV1: DIV0	Internal RC oscillator divider: 00b = 4 MHz 01b = 1 MHz 10 = 128 KHz 11b = 32 KHz
$\overline{\text{IFBD}}$	Internal crystal/resonator oscillator feedback resistor (1 M Ω): 0= disabled Internal feedback resistor disable (external feedback required) 1= enabled Internal feedback resistor enabled (valid when $\overline{\text{IRC}} = 1$)
$\overline{\text{CP}}$	Code protect enable: 0 = enabled (FUSE, code, and ID memories read back as garbled data) 1 = disabled (FUSE, code, and ID memories can be read normally)
WDTE	Watchdog timer enable: 0 = disabled 1 = enabled
FOSC2: FOSC0	External oscillator configuration (valid when $\overline{\text{IRC}} = 1$): 000b = LP1 – low power crystal (32KHz) 001b = LP2 – low power crystal/resonator (32 KHz to 1 MHz) 010b = XT1 – normal crystal/resonator (32 KHz to 10 MHz) 011b = XT2 – normal crystal/resonator (1MHz to 24 MHz) 100b = HS1 – high speed crystal/resonator/external crystal oscillator (1MHz to 50 MHz) 101b = HS2 – high speed crystal/resonator/external crystal oscillator (1 MHz to 50 MHz) 110b = HS3 – high speed crystal/resonator/external crystal oscillator (1 MHz to 75 MHz) 111b = RC network - OSC2 is pulled high with a weak pullup (no CLKOUT output) Note: The frequencies are target values.

5.2 FUSEX Word (Read/Program via Programming Command)

IRCTRIM2	PINS	IRCTRIM1	IRCTRIM0	OPTIONX/ STACKX	CF	BOR1	BOR0	BORTRIM1	BORTRIM0	BP1	BP0
----------	------	----------	----------	--------------------	----	------	------	----------	----------	-----	-----

Bit 11

Bit 0

- IRCTRIM2: Internal RC oscillator trim bits. This 3-bit field adjusts the operation of the internal RC oscillator to make it operate within the target frequency range 4 MHz plus or minus 8%. Parts are shipped from the factory untrimmed. The device relies on the programming toll to provide the trimming function.
- IRCTRIM0
- 000b = minimum frequency
 - 111b = maximum frequency
 - each step about 3%
- PINS Selects the number of pins.
- 0 = 18/20 pins
 - 1 = 28 pins
- OPTIONX/
STACKX OPTION Register Extension and Stack Extension. Set to 1 to disable the programmability of bit 6 and bit 7 in the OPTION register, the RTW and RTE_IE bits (in other words, to force these two bits to 1) and to limit the program stack size to two locations. Clear to 0 to enable programming of the RTW and RTE_IE bits in the OPTION register, and to extend the stack size to eight locations.
- CF active low – makes carry bit input to ADD and SUB instructions.
- BOR1: BOR0 Brown-Out Reset; These bits enable or disable the brown-out reset function and set the brown-out threshold voltage as follows:
- 00b = 4.2V
 - 01b = 2.6V
 - 10b = 2.2V
 - 11b = Brown-Out disabled
- BORTRIM1: Brown-Out trim bits (parts are shipped out of factory untrimmed).
- BORTRIM0
- BP1:BP0 Configure Memory Size:
- 00b = 1 page, 1 bank
 - 01b = 2 pages, 1 bank
 - 10b = 4 pages, 4 banks
 - 11b = 4 pages, 8 banks (default configuration)

5.3 DEVICE Word (Hard-Wired Read-Only)

1	1	1	1	1	1	0	0	1	1	1	0
---	---	---	---	---	---	---	---	---	---	---	---

Bit 11

Bit 0

6.0 MEMORY ORGANIZATION

6.1 Program Memory

The program memory is organized as 2K, 12-bit wide words. The program memory words are addressed sequentially by a binary program counter. The program counter starts at zero. If there is no branch operation, it will increment to the maximum value possible for the device and roll over and begin again.

Internally, the program memory has a semi-transparent page structure. A page is composed of 512 contiguous program memory words. The lower nine bits of the program counter are zeros at the first address of a page and ones at the last address of a page. This page structure has no effect on the program counter. The program counter will freely increment through the page boundaries.

6.1.1 Program Counter

The program counter contains the 11-bit address of the instruction to be executed. The lower eight bits of the program counter are contained in the PC register (02h) while the upper bits come from the upper three bits of the STATUS register (PA0, PA1, PA2). This is necessary to cause jumps and subroutine calls *across* program memory page boundaries. Prior to the execution of a branch operation, the user program must initialize the upper bits of the STATUS register to cause a branch to the desired page. An alternative method is to use the PAGE instruction, which automatically causes branch to the desired page, based on the value specified in the operand field. Upon reset, the program counter is initialized with 07FFh.

6.1.2 Subroutine Stack

The subroutine stack consists of eight 11-bit save registers. A physical transfer of register contents from the program counter to the stack or vice versa, and within the stack, occurs on all operations affecting the stack, primarily calls and returns. The stack is physically and logically separate from data RAM. The program cannot read or write the stack.

6.2 Data Memory

The data memory consists of 136 bytes of RAM, organized as eight banks of 16 registers plus eight registers which are not banked. Both banked and non-banked memory locations can be addressed directly or indirectly using the FSR (File Select Register). The special-function registers are mapped into the data memory.

6.2.1 File Select Register (04h)

Instructions that specify a register as the operand can only express five bits of register address. This means that only registers 00h to 1Fh can be accessed. The File Select Register (FSR) provides the ability to access registers beyond 1Fh.

Figure 6-1 shows how FSR can be used to address RAM locations. The three high-order bits of FSR select one of eight SRAM banks to be accessed. The five low-order bits select one of 32 SRAM locations within the selected bank. For the lower 16 addresses, Bank 0 is always accessed, irrespective of the three high-order bits. Thus, RAM register addresses 00h through 0Fh are "global" in that they can always be accessed, regardless of the contents of the FSR.

The entire data memory (including the dedicated-function registers) consists of the lower 16 bytes of Bank 0 and the upper 16 bytes of Bank 0 through Bank 7, for a total of $(1+8)*16 = 144$ bytes. Eight of these bytes are for the function registers, leaving 136 general-purpose memory locations. In the 18-pin SX packages, register RC is not used, which makes address 07h available as an additional general-purpose memory location.

Below is an example of how to write to register 10h in Bank 4:

```

mov    FSR, #90      ;Select Bank 4 by
                    ;setting FSR<7:5>
mov    $10, #64     ;load register 10h with
                    ;the literal 64h

```

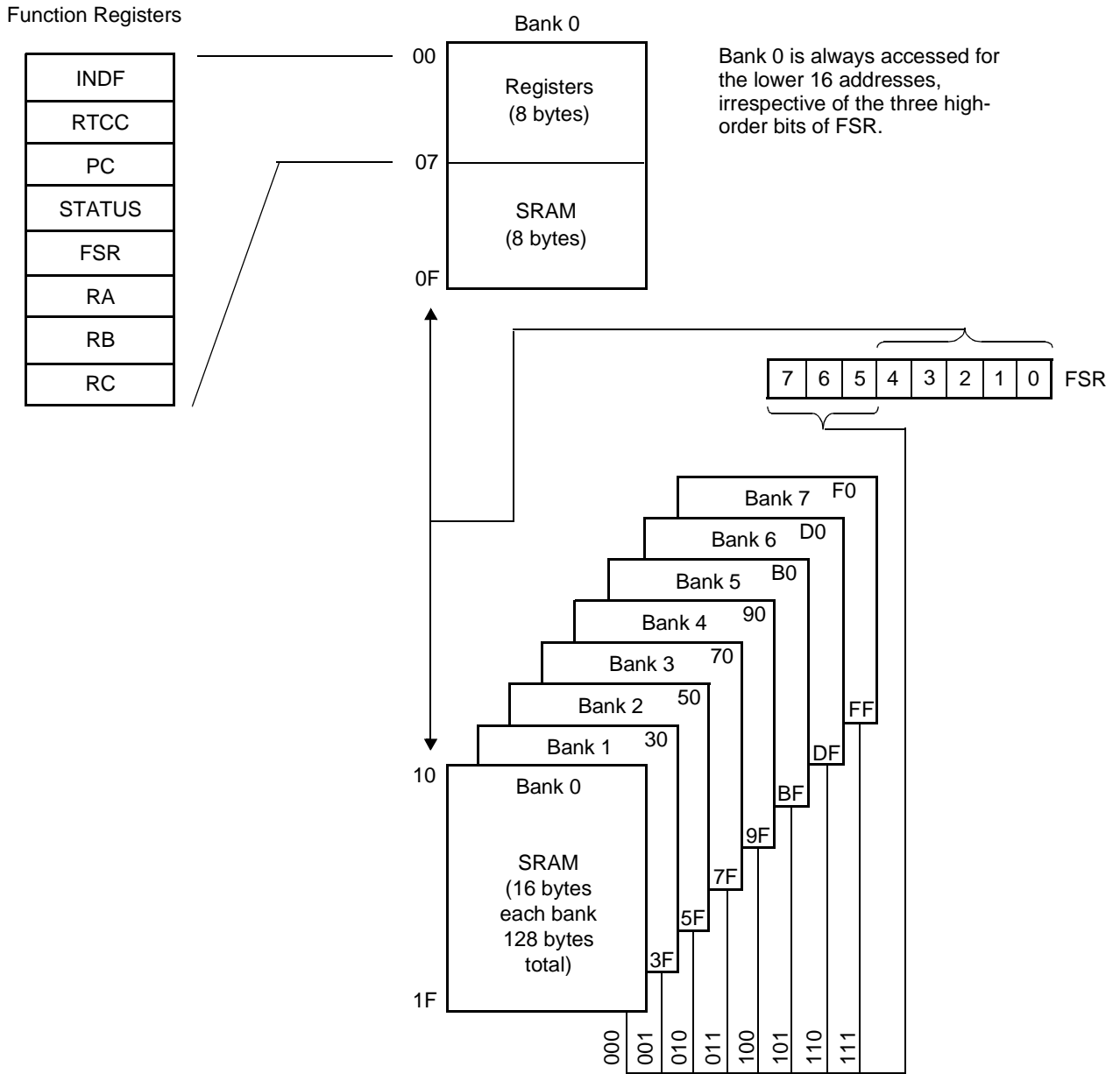

Figure 6-1. Data Memory Organization

7.0 POWER DOWN MODE

The power down mode is entered by executing the SLEEP instruction.

In power down mode, only the Watchdog Timer (WDT) is active. If the Watchdog Timer is enabled, upon execution of the SLEEP instruction, the Watchdog Timer is cleared, the TO (time out) bit is set in the STATUS register, and the PD (power down) bit is cleared in the STATUS register.

There are three different ways to exit from the power down mode: a timer overflow signal from the Watchdog Timer (WDT), a valid transition on any of the Multi-Input Wakeup pins (Port B pins), or through an external reset input on the MCLR pin.

To achieve the lowest possible power consumption, the Watchdog Timer should be disabled and the device should exit the power down mode through the Multi-Input Wakeup (MIWU) pins or an external reset.

7.1 Multi-Input Wakeup

Multi-Input Wakeup is one way of causing the device to exit the power down mode. Port B is used to support this

feature. The WKEN_B register (Wakeup Enable Register) allows any Port B pin or combination of pins to cause the wakeup. Clearing a bit in the WKEN_B register enables the wakeup on the corresponding Port B pin. If multi-input wakeup is selected to cause a wakeup, the trigger condition on the selected pin can be either rising edge (low to high) or falling edge (high to low). The WKED_B register (Wakeup Edge Select) selects the desired transition edge. Setting a bit in the WKED_B register selects the falling edge on the corresponding Port B. Clearing the bit selects the rising edge. The WKEN_B and WKED_B registers are set to FFh upon reset.

Once a valid transition occurs on the selected pin, the WKPND_B register (Wakeup Pending Register) latches the transition in the corresponding bit position. A logic '1' indicates the occurrence of the selected trigger edge on the corresponding Port B pin.

Upon exiting the power down mode, the Multi-Input Wakeup logic causes program counter to branch to the maximum program memory address (same as reset).

Figure 7-1 shows the Multi-Input Wakeup block diagram.

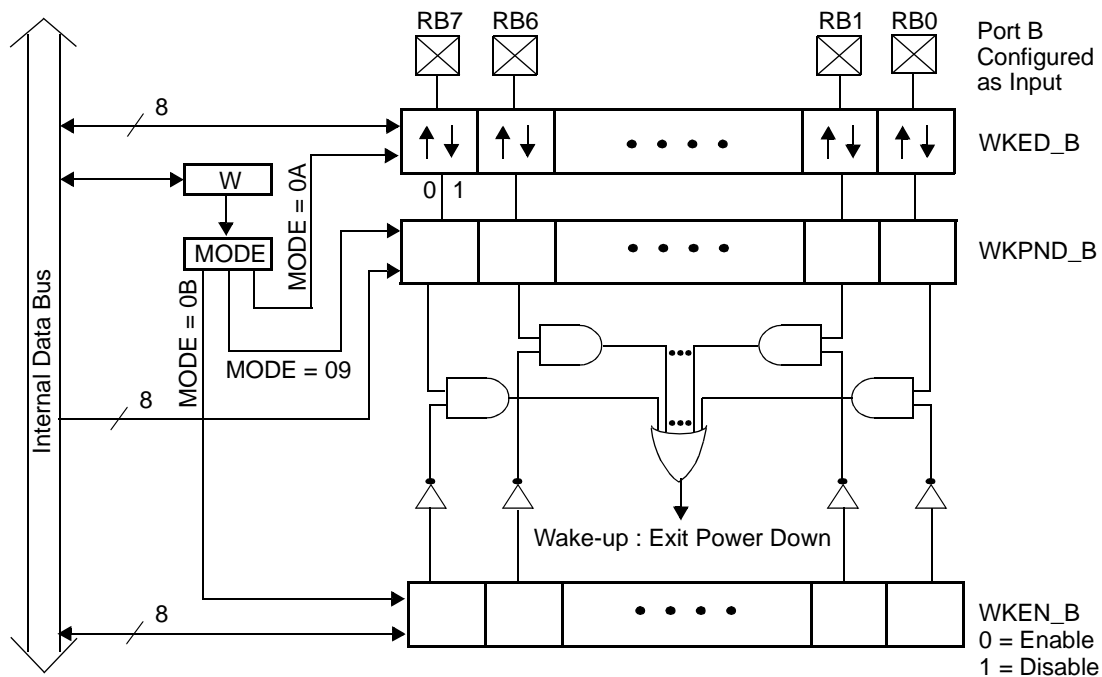

Figure 7-1. Multi-Input Wakeup Block Diagram

7.2 Port B MIWU/Interrupt Configuration

The WKPND_B register comes up with a random value upon reset. The user program must clear the register prior to enabling the wake-up condition or interrupts. The proper initialization sequence is:

1. Select the desired edge (through WKED_B register).
2. Clear the WKPND_B register.
3. Enable the Wakeup condition (through WKEN_B register).

Below is an example of how to read the WKPND_B register to determine which Port B pin caused the wakeup or interrupt, and to clear the WKPND_B register:

```
mov  M,#$09
clr  W
mov  !RB,W    ;W contains WKPND_B
                ;contents of W exchanged
                ;with contents of WKPND_B
```

The final “mov” instruction in this example performs an exchange of data between the working register (W) and the WKPND_B register. This exchange occurs only with Port B accesses. Otherwise, the “mov” instruction does not perform an exchange, but only moves data from the source to the destination.

Here is an example of a program segment that configures the RB0, RB1, and RB2 pins to operate as Multi-Input Wakeup/Interrupt pins, sensitive to falling edges:

```
mov  M,$0F    ;prepare to write port data
                ;direction registers
mov  W,$07    ;load W with the value 07h
mov  !RB,W    ;configure RB0-RB2 to be inputs

mov  M,$0A    ;prepare to write WKED_B
                ;(edge) register
                ;W contains the value 07h
mov  !RB,W    ;configure RB0-RB2 to sense
                ;falling edges
mov  M,$09    ;prepare to access WKPND_B
                ;(pending) register
mov  W,$00    ;clear W
mov  !RB,W    ;clear all wakeup pending bits

mov  M,$0B    ;prepare to write WKEN_B (enable)
                ;register
mov  W,$F8h   ;load W with the value F8h
mov  !RB,W    ;enable RB0-RB2 to operate as
                ;wakeup inputs
```

To prevent false interrupts, the enabling step (clearing bits in WKEN_B) should be done as the last step in a sequence of Port B configuration steps. After this program segment is executed, the device can receive interrupts on the RB0, RB1, and RB2 pins. If the device is put into the power down mode (by executing the SLEEP instruction), the device can then receive wakeup signals on those same pins.

All interrupts are global in nature; that is, no interrupt has priority over another. Interrupts are handled sequentially. Figure 8-2 shows the interrupt processing sequence. Once an interrupt is acknowledged, all subsequent global interrupts are disabled until return from servicing the current interrupt. The PC is pushed onto the single level interrupt stack, and the contents of the FSR, STATUS, and W registers are saved in their corresponding shadow registers. The status bits PA0, PA1, and PA2 bits are cleared after the STATUS register has been saved in its shadow register. The interrupt logic has its own single-level stack and is not part of the CALL subroutine stack. The vector for the interrupt service routine is address 0.

Once in the interrupt service routine, the user program must check all external interrupt pending bits (contained in the WKPND_B register) to determine the source of the interrupt. The interrupt service routine should clear the corresponding interrupt pending bit. If both internal and external interrupts are enabled, the user program may also need to read the contents of RTCC to determine any recent RTCC rollover. This is needed since there is no interrupt pending bit associated with the RTCC rollover.

Normally it is a requirement for the user program to process every interrupt without missing any. To ensure this, the longest path through the interrupt routine must take less time than the shortest possible delay between interrupts.

If an external interrupt occurs during the interrupt routine, the pending register will be updated but the trigger will be ignored unless interrupts are disabled at the beginning of the interrupt routine and enabled again at the end. This also requires that the new interrupt does not occur before interrupts are disabled in the interrupt routine. If there is a possibility of additional interrupts occurring before they can be disabled, the device will miss those interrupt triggers. In other words, using more than one interrupt, such as multiple external interrupts or both RTCC and external interrupts, can result in missed or, at best, jittery interrupt handling should one occur during the processing of another. When handling external interrupts, the interrupt routine should clear at least one pending register bit. The bit that is cleared should represent the interrupt being handled in order for the next interrupt to trigger.

Upon return from the interrupt service routine, the contents of PC, FSR, STATUS, and W registers are restored from their corresponding shadow registers. The interrupt service routine should end with instructions such as RETI and RETIW. RETI pops the interrupt stack and the special shadow registers used for storing W, STATUS, and FSR (preserved during interrupt handling). RETIW behaves like RETI but also adds W to RTCC. The interrupt return instruction enables the global interrupts.

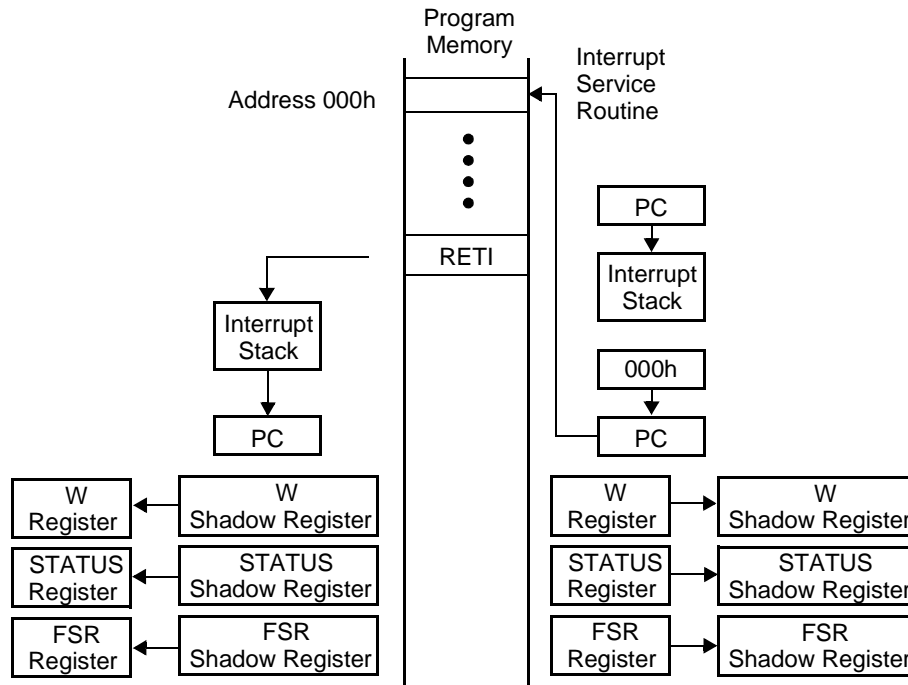

Note: The interrupt logic has its own single-level stack and is not part of the CALL subroutine stack.

Figure 8-2. Interrupt Processing

9.0 OSCILLATOR CIRCUITS

The device supports several user-selectable oscillator modes. The oscillator modes are selected by programming the appropriate values into the FUSE Word register. These are the different oscillator modes offered:

- LP: Low Power Crystal
- XT: Crystal/Resonator
- HS: High Speed Crystal/Resonator
- RC: External Resistor/Capacitor
Internal Resistor/Capacitor

9.1 XT, LP or HS modes

In XT, LP or HS, modes, you can use either an external resonator network or an external clock signal as the device clock.

To use an external resonator network, you connect a crystal or ceramic resonator to the OSC1/CLKIN and OSC2/CLKOUT pins according to the circuit configuration shown in Figure 9-1. A parallel resonant crystal type is recommended. Use of a series resonant crystal may result in a frequency that is outside the crystal manufacturer specifications. Table 9-1 shows the recommended external components associated with a crystal-based oscillator. Table 9-2 shows the recommended external component values for a resonator-based oscillator.

Bits 0, 1 and 5 of the FUSE register (FOSC1:FOSC2) are used to configure the different external resonator/crystal oscillator modes. These bits allow the selection of the appropriate gain setting for the internal driver to match the desired operating frequency. If the XT, LP, or HS mode is selected, the OSC1/CLKIN pin can be driven by an external clock source rather than a resonator network, as long as the clock signal meets the specified duty cycle, rise and fall times, and input levels (Figure 9-2). In this case, the OSC2/CLKOUT pin should be left open.

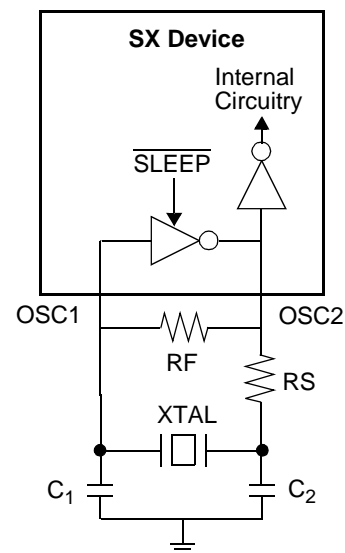

Figure 9-1. Crystal Operation (or Ceramic Resonator) (HS, XT or LP OSC Configuration)

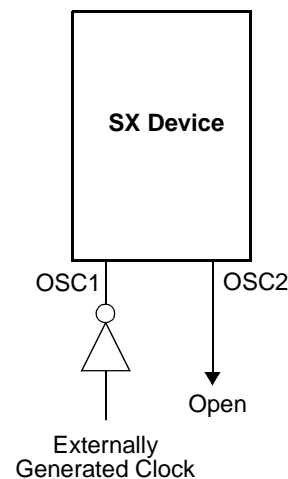

Figure 9-2. External Clock Input Operation (HS, XT or LP OSC Configuration)

Table 9-1. External Component Selection for Crystal Oscillator (Vdd=5.0V), $R_s = 0 \Omega$

FOSC2:FOSC0	Crystal Frequency	C1	C2	R_F
010	4 MHz	15 pF	22 pF	1 M Ω
011	8 MHz	56 pF	33 pF	1 M Ω
011	20 MHz	33 pF	22 pF	1 M Ω
011	32 MHz	15 pF	22 pF	1 M Ω
100	50* MHz	15 pF	15 pF	1 M Ω

* 50 MHz fundamental crystal

Table 9-2. External Component Selection for Murata Ceramic Resonators (Vdd=5.0V)

FOSC2:FOSC0	Resonator Frequency	Resonator Part Number	C1	C2	R _F	R _S
011	4 MHz	CSA4.00MG	30 pF	30 pF	1MΩ	0 Ω
011	4 MHz	CST4.00MGW	Internal (30 pF)	Internal (30 pF)	1 MΩ	0 Ω
011	4 MHz	CSTCC4.00G0H6	Internal (47 pF)	Internal (47 pF)	1 MΩ	0 Ω
011	8 MHz	CSA8.00MTZ	30 pF	30 pF	1 MΩ	0 Ω
011	8 MHz	CST8.00MTW	Internal (30 pF)	Internal (30 pF)	1 MΩ	0 Ω
011	8 MHz	CSTCC8.00MG0H6	Internal (47 pF)	Internal (47 pF)	1 MΩ	0 Ω
011	20 MHz	CSA20.00MXZ040	5 pF	5 pF	1 MΩ	0 Ω
011	20 MHz	CST20.00MXW0H1	Internal (5 pF)	Internal (5 pF)	1 MΩ	0 Ω
011	20 MHz	CSACV20.00MXJ040	5 pF	5 pF	22 kΩ	0 Ω
011	20 MHz	CSTCV20.00MXJ0H1	Internal (5 pF)	Internal (5 pF)	22 kΩ	0 Ω
100	33 MHz	CSA33.00MXJ040	5 pF	5 pF	1 MΩ	0 Ω
100	33 MHz	CST33.00MXW040	Internal (5 pF)	Internal (5 pF)	1 MΩ	0 Ω
100	33 MHz	CSACV33.00MXJ040	5 pF	5 pF	1 MΩ	0 Ω
100	33 MHz	CSTCV33.00MXJ040	Internal (5 pF)	Internal (5 pF)	1 MΩ	0 Ω
101	50 MHz	CSA50.00MXZ040	15 pF	15 pF	10 kΩ	0 Ω
101	50 MHz	CST50.00MXW0H3	Internal (15 pF)	Internal (15 pF)	10 kΩ	0Ω
101	50 MHz	CSACV50.00MXJ040	15 pF	15 pF	10 kΩ	0 Ω
101	50 MHz	CSTCV50.00MXJ0H3	Internal (15 pF)	Internal (15 pF)	10 kΩ	0 Ω

9.2 External RC Mode

The external RC oscillator mode provides a cost-effective approach for applications that do not require a precise operating frequency. In this mode, the RC oscillator frequency is a function of the supply voltage, the resistor (R) and capacitor (C) values, and the operating temperature. In addition, the oscillator frequency will vary from unit to unit due to normal manufacturing process variations. Furthermore, the difference in lead frame capacitance between package types also affects the oscillation frequency, especially for low C values. The external R and C component tolerances contribute to oscillator frequency variation as well.

Figure 9-3 shows the external RC connection diagram. The recommended R value is from 3k Ω to 100k Ω . For R values below 2.2k Ω , the oscillator may become unstable, or may stop completely. For very high R values (such as 1 M Ω), the oscillator becomes sensitive to noise, humidity, and leakage.

Although the oscillator will operate with no external capacitor (C = 0pF), it is recommended that you use values above 20 pF for noise immunity and stability. With no or small external capacitance, the oscillation frequency can vary significantly due to variation in PCB trace or package lead frame capacitances.

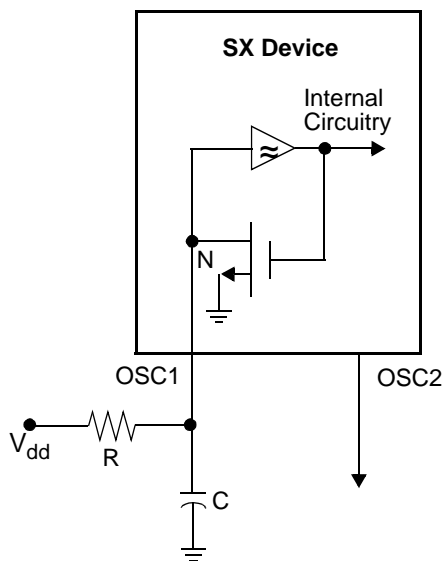

Figure 9-3. RC Oscillator Mode

9.3 Internal RC Mode

The internal RC mode uses an internal oscillator, so the device does not need any external components. At 4 MHz, the internal oscillator provides typically $\pm 8\%$ accuracy over the allowed temperature range. The internal clock frequency can be divided down to provide one of eight lower-frequency choices by selecting the desired value in the FUSE Word register. The frequency range is from 31.25 KHz to 4 MHz. The default operating frequency of the internal RC oscillator may not be 4 MHz. This is due to the fact that the SX device requires trimming to obtain 4 MHz operation. The parts shipped out of the factory are not trimmed. The device relies on the programming tool provided by the third party vendors to support trimming.

10.0 REAL TIME CLOCK (RTCC)/WATCHDOG TIMER

The device contains an 8-bit Real Time Clock/Counter (RTCC) and an 8-bit Watchdog Timer (WDT). An 8-bit programmable prescaler extends the RTCC to 16 bits. If the prescaler is not used for the RTCC, it can serve as a postscaler for the Watchdog Timer. Figure 10-1 shows the RTCC and WDT block diagram.

10.1 RTCC

RTCC is an 8-bit real-time timer that is incremented once each instruction cycle or from a transition on the RTCC pin. The on-board prescaler can be used to extend the RTCC counter to 16 bits.

The RTCC counter can be clocked by the internal instruction cycle clock or by an external clock source presented at the RTCC pin.

To select the internal clock source, bit 5 of the OPTION register should be cleared. In this mode, RTCC is incremented at each instruction cycle unless the prescaler is selected to increment the counter.

To select the external clock source, bit 5 of the OPTION register must be set. In this mode, the RTCC counter is incremented with each valid signal transition at the RTCC pin. By using bit 4 of the OPTION register, the transition can be programmed to be either a falling edge or rising edge. Setting the control bit selects the falling edge to increment the counter. Clearing the bit selects the rising edge.

The RTCC generates an interrupt as a result of an RTCC rollover from 0FF to 000. There is no interrupt pending bit to indicate the overflow occurrence. The RTCC register must be sampled by the program to determine any overflow occurrence.

10.2 Watchdog Timer

The watchdog logic consists of a Watchdog Timer which shares the same 8-bit programmable prescaler with the RTCC. The prescaler actually serves as a postscaler if used in conjunction with the WDT, in contrast to its use as a prescaler with the RTCC.

10.3 The Prescaler

The 8-bit prescaler may be assigned to either the RTCC or the WDT through the PSA bit (bit 3 of the OPTION register). Setting the PSA bit assigns the prescaler to the WDT. If assigned to the WDT, the WDT clocks the prescaler and the prescaler divide rate is selected by the PS0, PS1, and PS2 bits located in the OPTION register. Clearing the PSA bit assigns the prescaler to the RTCC. Once assigned to the RTCC, the prescaler clocks the RTCC and the divide rate is selected by the PS0, PS1, and PS2 bits in the OPTION register. The prescaler is not mapped into the data memory, so run-time access is not possible.

The prescaler cannot be assigned to both the RTCC and WDT simultaneously.

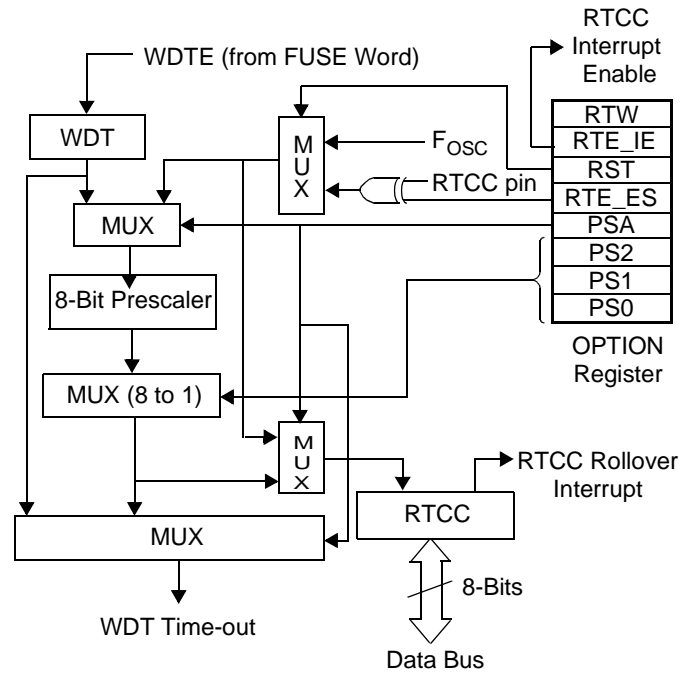

Figure 10-1. RTCC and WDT Block Diagram

11.0 COMPARATOR

The device contains an on-chip differential comparator. Ports RB0-RB2 support the comparator. Ports RB1 and RB2 are the comparator negative and positive inputs, respectively, while Port RB0 serves as the comparator output pin. To use these pins in conjunction with the comparator, the user program must configure Ports RB1 and RB2 as inputs and Port RB0 as an output. The CMP_B register is used to enable the comparator, to read the output of the comparator internally, and to enable the output of the comparator to the comparator output pin.

The comparator enable bits are set to “1” upon reset, thus disabling the comparator. To avoid drawing additional current during the power down mode, the comparator should be disabled before entering the power down mode. Here is an example of how to setup the comparator and read the CMP_B register.

```

mov M,#$08 ;set MODE register to access
           ;CMP_B

mov W,#$00 ;clear W

mov !RB,W  ;enable comparator and its
           ;output

...       ;delay after enabling
           ;comparator for response

mov M,#$08 ;set MODE register to access
           ;CMP_B

mov W,#$00 ;clear W

mov !RB,W  ;enable comparator and its
           ;output and also read CMP_B
           ;(exchange W and CMB_B)

and W,#$01 ;set/clear Z bit based on
           ;comparator result

snb $03.2  ;test Z bit in STATUS reg
           ;(0 => RB2<RB1)

jmp rb2_hi ;jump only if RB2>RB1

...

```

The final “mov” instruction in this example performs an exchange of data between the working register (W) and the CMP_B register. This exchange occurs only with Port B accesses. Otherwise, the “mov” instruction does not perform an exchange, but only moves data from the source to the destination.

Figure 11-1 shows the comparator block diagram.

CMP_B - Comparator Enable/Status Register

$\overline{\text{CMP_EN}}$	$\overline{\text{CMP_OE}}$	Reserved	CMP_RES
Bit 7	Bit 6	Bits 5–1	Bit 0

CMP_RES	Comparator result: 1 for RB2>RB1 or 0 for RB2<RB1. Comparator must be enabled (CMP_EN = 0) to read the result. The result can be read whether or not the CMP_OE bit is cleared.
$\overline{\text{CMP_OE}}$	When cleared to 0, enables the comparator output to the RB0 pin.
$\overline{\text{CMP_EN}}$	When cleared to 0, enables the comparator.

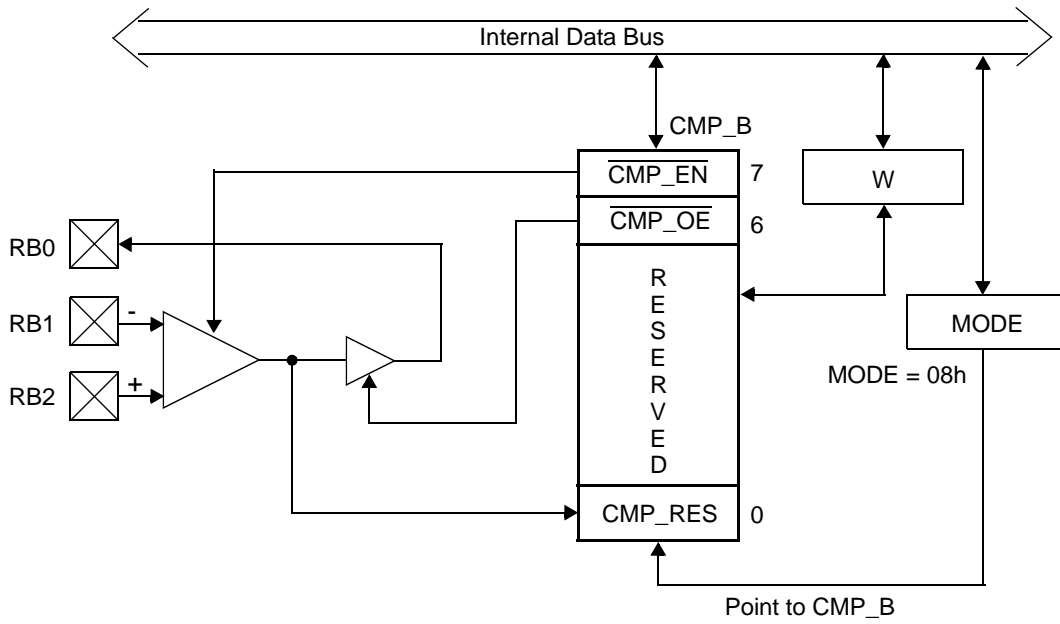
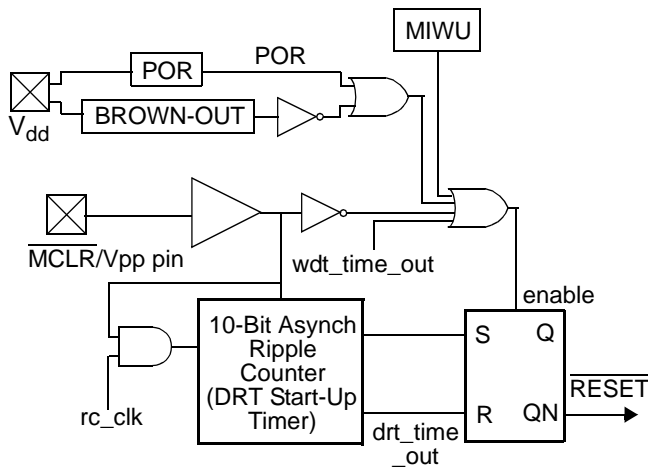

Figure 11-1. Comparator Block Diagram

12.0 RESET

Power-On-Reset, Brown-Out reset, watchdog reset, or external reset initializes the device. Each one of these reset conditions causes the program counter to branch to the top of the program memory. For example, on the device with 2048K words of program memory, the program counter is initialized to 07FF.

The device incorporates an on-chip Power-On Reset (POR) circuit that generates an internal reset as V_{dd} rises during power-up. Figure 12-1 is a block diagram of the circuit. The circuit contains an 10-bit Delay Reset Timer (DRT) and a reset latch. The DRT controls the reset time-out delay. The reset latch controls the internal reset signal. Upon power-up, the reset latch is set (device held in reset), and the DRT starts counting once it detects a valid logic high signal at the MCLR pin. Once DRT reaches the end of the timeout period (typically 72 msec), the reset latch is cleared, releasing the device from reset state.



Note: Ripple counter is 10 bits for Power on Reset (POR) only.

Figure 12-1. Block Diagram of On-Chip Reset Circuit

Figure 12-2 shows a power-up sequence where $\overline{\text{MCLR}}$ is not tied to the V_{dd} pin and V_{dd} signal is allowed to rise and stabilize before MCLR pin is brought high. The device will actually come out of reset T_{drt} msec after MCLR goes high.

The brown-out circuitry resets the chip when device power (V_{dd}) dips below its minimum allowed value, but not to zero, and then recovers to the normal value.

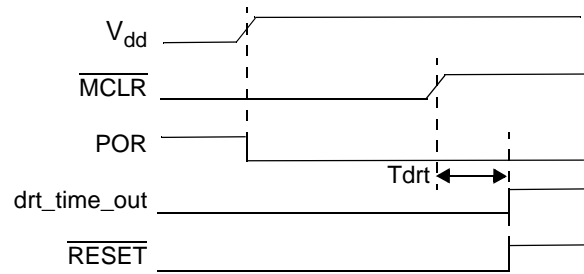

Figure 12-2. Time-Out Sequence on Power-Up (MCLR not tied to V_{dd})

Figure 12-3 shows the on-chip Power-On Reset sequence where the $\overline{\text{MCLR}}$ and V_{dd} pins are tied together. The V_{dd} signal is stable before the DRT time-out period expires. In this case, the device will receive a proper reset. However, Figure 12-4 depicts a situation where V_{dd} rises too slowly. In this scenario, the DRT will time-out prior to V_{dd} reaching a valid operating voltage level ($V_{\text{dd min}}$). This means the device will come out of reset and start operating with the supply voltage not at a valid level. In this situation, it is recommended that you use the external RC circuit shown in Figure 12-5. The RC delay should exceed the time period it takes V_{dd} to reach a valid operating voltage

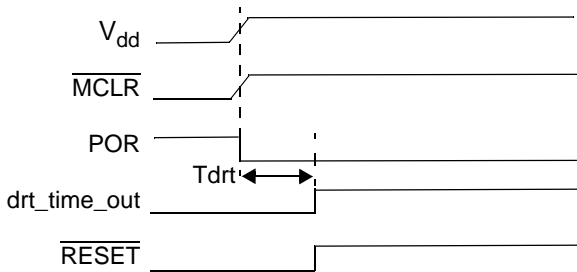

Figure 12-3. Time-out Sequence on Power-up ($\overline{\text{MCLR}}$ tied to V_{dd}): Fast V_{dd} Rise Time

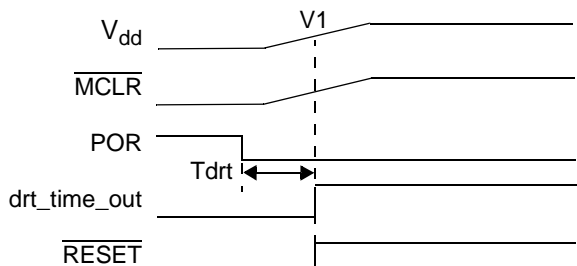

Figure 12-4. Time-out Sequence on Power-up ($\overline{\text{MCLR}}$ tied to V_{dd}): Slow Rise Time

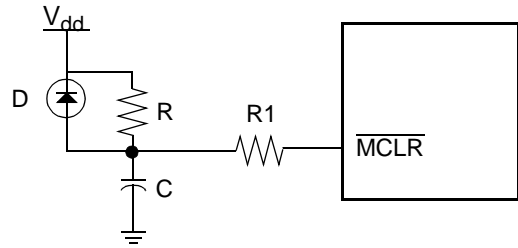

Figure 12-5. External Power-On Reset Circuit (For Slow V_{dd} Power-up)

Note 1: The external Power-On Reset circuit is required only if V_{dd} power-up is too slow. The diode D helps discharge the capacitor quickly when V_{dd} powers down.

Note 2: $R < 40 \text{ k}\Omega$ is recommended to make sure that voltage drop across R does not violate the device electrical specifications.

Note 3: $R1 = 100\Omega$ to $1\text{k}\Omega$ will limit any current flowing into $\overline{\text{MCLR}}$ from external capacitor C. This helps prevent $\overline{\text{MCLR}}$ pin breakdown due to Electrostatic Discharge (ESD) or Electrical Overstress (EOS).

13.0 BROWN-OUT DETECTOR

The on-chip brown-out detection circuitry resets the device when V_{dd} dips below the specified brown-out voltage. The device is held in reset as long as V_{dd} stays below the brown-out voltage. The device will come out of reset when V_{dd} rises above the brown-out voltage. The brown-out level is preset to approximately 4.2V at the factory. The brown-out circuit can be disabled through BOR0 and BOR1 bits contained in the FUSEX Word register.

14.0 REGISTER STATES UPON DIFFERENT RESET OPERATIONS

The effect of different reset operation on a register depends on the register and the type of reset operation. Some registers are initialized to specific values, some are left unchanged, some are undefined, and some are initialized to an unknown value.

A register that starts with an unknown value should be initialized by the software to a known value; you cannot simply test the initial state and rely on it starting in that state consistently.

Table 14-1 lists the SX registers and shows the state of each register upon different reset.

Table 14-1. Register States Upon Different Resets

Register	Power-On	Wakeup	Brown-out	Watchdog Timeout	MCLR
W	Undefined	Unchanged	Undefined	Unchanged	Unchanged
OPTION	FFh	FFh	FFh	FFh	FFh
MODE	0Fh	0Fh	0Fh	0Fh	0Fh
RTCC (01h)	Undefined	Unchanged	Undefined	Unchanged	Unchanged
PC (02h)	FFh	FFh	FFh	FFh	FFh
STATUS (03h)	Bits 0-2: Undefined Bits 3-4: 11 Bits 5-7: 000	Bits 0-2: Unchanged. Bits 3-4: Unch. Bits 5-7: 000	Bits 0-4: Undefined Bits 5-7: 000	Bits 0-2: Unchanged Bits 3-4: (Note 1) Bits 5-7: 000	Bits 0-2: Unchanged Bits 3-4: (Note 2) Bits 5-7: 000
FSR (04h)	Undefined	Bits 0-6: Unchanged Bit 7: 1	Bits 0-6: Undefined Bit 7: 1	Bits 0-6: Unchanged Bit 7: 1	Bits 0-6: Unchanged Bit 7: 1
RA/RB/RC Direction	FFh	FFh	FFh	FFh	FFh
RA/RB/RC Data	Undefined	Unchanged	Undefined	Unchanged	Unchanged
Other File Registers - SRAM	Undefined	Unchanged	Undefined	Unchanged	Unchanged
CMP_B	Bits 0, 6-7: 1 Bits 1-5: Undefined	Bits 0, 6-7: 1 Bits 1-5: Undefined	Bits 0, 6-7: 1 Bits 1-5: Undefined	Bits 0, 6-7: 1 Bits 1-5: Undefined	Bits 0, 6-7: 1 Bits 1-5: Undefined
WKPND_B	Undefined	Unchanged	Undefined	Unchanged	Unchanged
WKED_B	FFh	FFh	FFh	FFh	FFh
WKEN_B	FFh	FFh	FFh	FFh	FFh
ST_B/ST_C	FFh	FFh	FFh	FFh	FFh
LVL_A/LVL_B/LVL_C	FFh	FFh	FFh	FFh	FFh
PLP_A/PLP_B/PLP_C	FFh	FFh	FFh	FFh	FFh
Watchdog Counter	Undefined	Unchanged	Undefined	Unchanged	Unchanged
NOTE: 1. Watchdog reset during power down mode: 00 (TO, PD) Watchdog reset during Active mode: 01 (TO, PD)					
NOTE: 2. External reset during power down mode: 10 (TO, PD) External reset during Active mode: Unchanged (TO, PD)					

15.0 INSTRUCTION SET

As mentioned earlier, the SX family of devices uses a modified Harvard architecture with memory-mapped input/output. The device also has a RISC type architecture in that there are 43 single-word basic instructions. The instruction set contains byte-oriented file register, bit-oriented file register, and literal/control instructions.

Working register W is one of the CPU registers, which serves as a pseudo accumulator. It is a pseudo accumulator in a sense that it holds the second operand, receives the literal in the immediate type instructions, and also can be program-selected as the destination register. The bank of 31 file registers can also serve as the primary accumulators, but they represent the first operand and may be program-selected as the destination registers.

15.1 Instruction Set Features

1. All single-word (12-bit) instructions for compact code efficiency.
2. All instructions are single cycle except the jump type instructions (JMP, CALL) and failed test instructions (DECSZ fr, INCSZ fr, SB bit, SNB bit), which are two-cycle.
3. A set of File registers can be addressed directly or indirectly, and serve as accumulators to provide first operand; W register provides the second operand.
4. Many instructions include a destination bit which selects either the register file or the accumulator as the destination for the result.
5. Bit manipulation instructions (Set, Clear, Test and Skip if Set, Test and Skip if Clear).
6. STATUS Word register memory-mapped as a register file, allowing testing of status bits (carry, digit carry, zero, power down, and timeout).
7. Program Counter (PC) memory-mapped as register file allows W to be used as offset register for indirect addressing of program memory.
8. Indirect addressing data pointer FSR (file select register) memory-mapped as a register file.
9. IREAD instruction allows reading the instruction from the program memory addressed by W and upper four bits of MODE register.
10. Eight-level, 11-bit push/pop hardware stack for sub-routine linkage using the Call and Return instructions.
11. Six addressing modes provide great flexibility.

15.2 Instruction Execution

An instruction goes through a four-stage pipeline to be executed (Figure 15-1). The first instruction is fetched from the program memory on the first clock cycle. On the second clock cycle, the first instruction is decoded and the second instruction is fetched. On the third clock cycle, the first instruction is executed, the second instruction is decoded, and the third instruction is fetched. On the fourth clock cycle, the first instruction's results are written to its destination, the second instruction is executed, the third instruction is decoded, and the fourth instruction is

fetched. Once the pipeline is full, instructions are executed at the rate of one per clock cycle.

Instructions that directly affect the contents of the program counter (such as jumps and calls) require that the pipeline be cleared and subsequently refilled. Therefore, these instruction take more than one clock cycle.

The instruction execution time is derived by dividing the oscillator frequency by either one (turbo mode) or four (non-turbo mode). The divide-by factor is selected through the FUSE Word register.

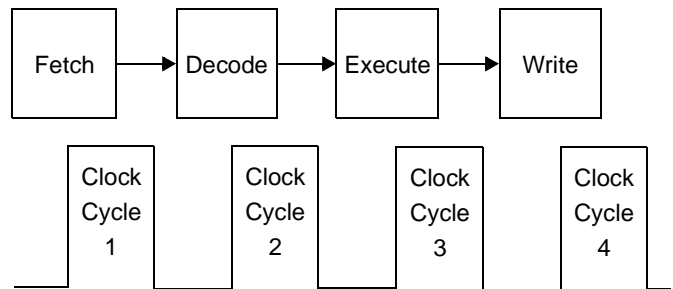

Figure 15-1. Pipeline and Clock Scheme

15.3 Addressing Modes

The device support the following addressing modes:

- Data Direct
- Data Indirect
- Immediate
- Program Direct
- Program Indirect
- Relative

Both direct and indirect addressing modes are available. The INDF register, though physically not implemented, is used in conjunction with the indirect data pointer (FSR) to perform indirect addressing. An instruction using INDF as its operand field actually performs the operation on the register pointed by the contents of the FSR. Consequently, processing two multiple-byte operands requires alternate loading of the operand addresses into the FSR pointer as the multiple byte data fields are processed.

Examples:

Direct addressing:

```
mov RA,#01 ;move "1" to RA
```

Indirect Addressing:

```
mov FSR,#RA ;FSR = address of RA
mov INDF,#$01 ;move "1" to RA
```

15.4 RAM Addressing

Direct Addressing

The FSR register must be initialized with an appropriate value in order to address the desired RAM register. The following table and code example show how to directly access the banked registers.

Bank	FSR Value
0	010h
1	030h
2	050h
3	070h
4	090h
5	0B0h
6	0D0h
7	0F0h

```

mov  FSR,#$070    ;Select RAM Bank 3
clr  $010         ;Clear register 10h on
                    ;Bank 3

mov  FSR,#$D0     ;Select RAM Bank 6
clr  $010         ;Clear register 10h on
                    ;Bank 6

```

Indirect Addressing

To access any register via indirect addressing, simply move the eight-bit address of the desired register into the FSR and use INDF as the operand. The example below shows how to clear all RAM locations from 10h to 1Fh in all eight banks:

```

clr  FSR          ;clear FSR to 00h (at address
                    ;04h)
:loop setb SFR.4   ;set bit 4: address 10h-1Fh,
                    ;30-3Fh, etc
clr  INDF         ;clear register pointed to by
                    ;FSR
incsz FSR         ;increment FSR and test, skip
                    ;jmp if 00h
jmp  :loop        ;jump back and clear next
                    ;register

```

15.5 The Bank Instruction

Often it is desirable to set the bank select bits of the FSR register in one instruction cycle. The Bank instruction provides this capability. This instruction sets the upper bits of the FSR to point to a specific RAM bank without affecting the other FSR bits.

Example:

```

bank $F0          ;Select Bank 7 in FSR
inc  $1F          ;increment file register
                    ;1Fh in Bank 7

```

15.6 Bit Manipulation

The instruction set contains instructions to set, reset, and test individual bits in data memory. The device is capable of bit addressing anywhere in data memory.

15.7 Input/Output Operation

The device contains three registers associated with each I/O port. The first register (Data Direction Register), configures each port pin as a Hi-Z input or output. The second register (TTL/CMOS Register), selects the desired input level for the input. The third register (Pull-Up Register), enables a weak pull-up resistor on the pin configured as an input. In addition to using the associated port registers, appropriate values must be written into the MODE register to configure the I/O ports.

When two successive read-modify-write instructions are used on the same I/O port with a very high clock rate, the "write" part of one instruction might not occur soon enough before the "read" part of the very next instruction, resulting in getting "old" data for the second instruction. To ensure predictable results, avoid using two successive read-modify-write instructions that access the same port data register if the clock rate is high.

15.8 Increment/Decrement

The bank of 31 registers serves as a set of accumulators. The instruction set contains instructions to increment and decrement the register file. The device also includes both INCSZ fr (increment file register and skip if zero) and DECSZ fr (decrement file register and skip if zero) instructions.

15.9 Loop Counting and Data Pointing Testing

The device has specific instructions to facilitate loop counting. The DECSZ fr (decrement file register and skip if zero) tests any one of the file registers and skips the next instruction (which can be a branch back to loop) if the result is zero.

15.10 Branch and Loop Call Instructions

The device contains an 8-level hardware stack where the return address is stored with a subroutine call. Multiple stack levels allow subroutine nesting. The instruction set supports absolute address branching.

15.10.1 Jump Operation

When a JMP instruction is executed, the lower nine bits of the program counter is loaded with the address of the specified label. The upper two bits of the program counter are loaded with the page select bits, PA1:PA0, contained in the STATUS register. Therefore, care must be exercised to ensure the page select bits are pointing to the correct page *before* the jump occurs.

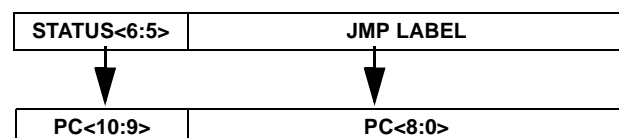

15.10.2 Page Jump Operation

When a JMP instruction is executed and the intended destination is on a different page, the page select bits must be initialized with appropriate values to point to the desired page before the jump occurs. This can be done easily with SETB and CLRB instructions or by writing a value to the STATUS register. The device also has the PAGE instruction, which automatically selects the page in a single-cycle execution.

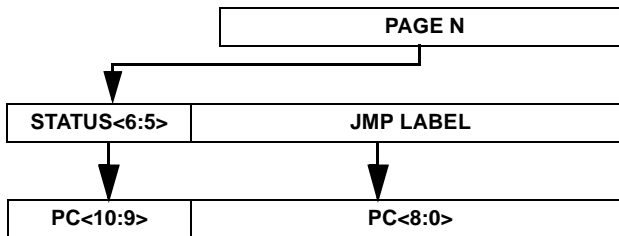

Note: "N" must be 0, 1, 2, or 3.

15.10.3 Call Operation

The following happens when a CALL instruction is executed:

- The current value of the program counter is incremented and pushed onto the top of the stack.
- The lower eight bits of the label address are copied into the lower eight bits of the program counter.
- The ninth bit of the Program Counter is cleared to zero.
- The page select bits (in STATUS register) are copied into the upper two bits of the Program Counter.

This means that the call destination must *start* in the lower half of any page. For example, 00h-0FFh, 200h-2FFh, 400h-4FFh, etc.

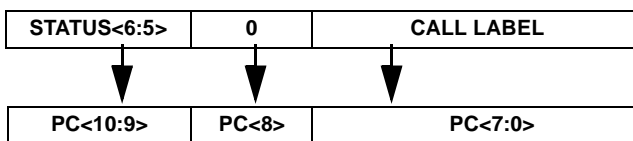

15.10.4 Page Call Operation

When a subroutine that resides on a different page is called, the page select bits must contain the proper values to point to the desired page before the call instruction is executed. This can be done easily using SETB and CLRB instructions or writing a value to the STATUS register. The device also has the PAGE instruction, which automatically selects the page in a single-cycle execution.

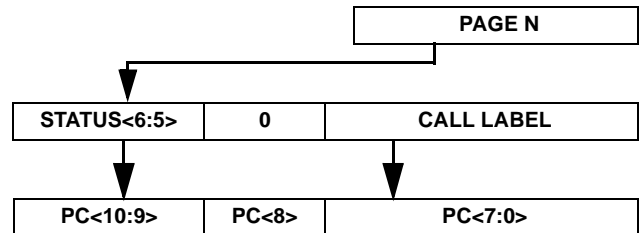

Note: "N" must be 0, 1, 2, or 3.

15.11 Return Instructions

The device has several instructions for returning from subroutines and interrupt service routines. The return from subroutine instructions are RET (return without affecting W), RETP (same as RET but affects PA1:PA0), RETI (return from interrupt), RETIW (return and add W to RTCC), and RETW #literal (return and place literal in W). The literal serves as an immediate data value from memory. This instruction can be used for table lookup operations. To do table lookup, the table must contain a string of RETW #literal instructions. The first instruction just in front of the table calculates the offset into the table. The table can be used as a result of a CALL.

15.12 Subroutine Operation

15.12.1 Push Operation

When a subroutine is called, the return address is pushed onto the subroutine stack. Specifically, each address in the stack is moved to the next lower level in order to make room for the new address to be stored. Stack 1 receives the contents of the program counter. Stack 8 is overwritten with what was in Stack 7. The contents of stack 8 are lost.

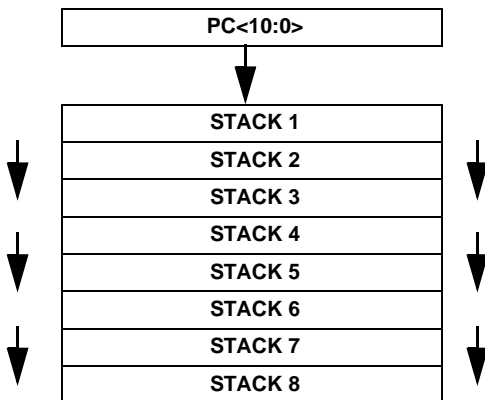

15.12.2 Pop Operation

When a return instruction is executed the subroutine stack is popped. Specifically, the contents of Stack 1 are copied into the program counter and the contents of each stack level are moved to the next higher level. For example, Stack 1 receives the contents of Stack 2, etc., until Stack 7 is overwritten with the contents of Stack 8. Stack 8 is left unchanged, so the contents of Stack 8 are duplicated in Stack 7.

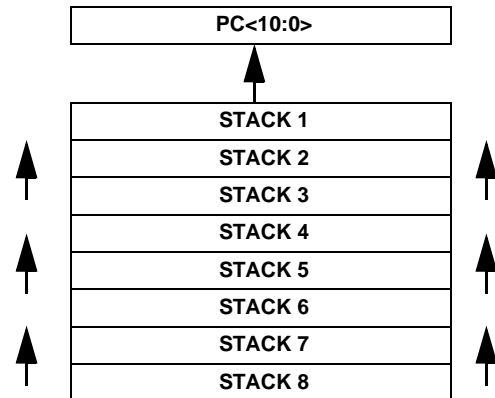

15.13 Comparison and Conditional Branch Instructions

The instruction set includes instructions such as DECSZ fr (decrement file register and skip if zero), INCSZ fr (increment file register and skip if zero), SNB bit (bit test file register and skip if bit clear), and SB bit (bit test file register and skip if bit set). These instructions will cause the next instruction to be skipped if the tested condition is true. If a skip instruction is immediately followed by a PAGE or BANK instruction (and the tested condition is true) then two instructions are skipped and the operation consumes three cycles. This is useful for conditional branching to another page where a PAGE instruction precedes a JMP. If several PAGE and BANK instructions immediately follow a skip instruction then they are all skipped plus the next instruction and a cycle is consumed for each.

15.14 Logical Instruction

The instruction set contain a full complement of the logical instructions (AND, OR, Exclusive OR), with the W register and a selected memory location (using either direct or indirect addressing) serving as the two operands.

15.15 Shift and Rotate Instructions

The instruction set includes instructions for left or right rotate-through-carry.

15.16 Complement and SWAP

The device can perform one's complement operation on the file register (fr) and W register. The MOV W,<>fr instruction performs nibble-swap on the fr and puts the value into the W register.

15.17 Key to Abbreviations and Symbols

Symbol	Description
W	Working register
fr	File register (memory-mapped register in the range of 00h to FFh)
PC	Lower eight bits of program counter (file register 02h)
STATUS	STATUS register (file register 03h)
FSR	File Select Register (file register 04h)
C	Carry bit in STATUS register (bit 0)
DC	Digit Carry bit in STATUS register (bit 1)
Z	Zero bit in STATUS register (bit 2)
PD	Power Down bit in STATUS register (bit 3)
TO	Watchdog Timeout bit in STATUS register (bit 4)
PA2:PA0	Page select bits in STATUS register (bits 7:5)
OPTION	OPTION register (not memory-mapped)
WDT	Watchdog Timer register (not memory-mapped)
MODE	MODE register (not memory-mapped)
rx	Port control register pointer (RA, RB, or RC)
!	Non-memory-mapped register designator
f	File register address bit in opcode
k	Constant value bit in opcode
n	Numerical value bit in opcode
b	Bit position selector bit in opcode
.	File register / bit selector separator in assembly language instruction
#	Immediate literal designator in assembly language instruction
lit	Literal value in assembly language instruction
addr8	8-bit address in assembly language instruction
addr9	9-bit address in assembly language instruction
addr12	12-bit address in assembly language instruction
/	Logical 1's complement
	Logical OR
^	Logical exclusive OR
&	Logical AND
<>	Swap high and low nibbles (4-bit segments)
<<	Rotate left through carry bit
>>	Rotate right through carry bit
--	Decrement file register
++	Increment file register

16.0 INSTRUCTION SET SUMMARY TABLE

Table 16-1 lists all of the instructions, organized by category. For each instruction, the table shows the instruction mnemonic (as written in assembly language), a brief description of what the instruction does, the number of instruction cycles required for execution, the binary opcode, and the status bits affected by the instruction.

The “Cycles” column typically shows a value of 1, which means that the overall throughput for the instruction is one per clock cycle. In some cases, the exact number of

cycles depends on the outcome of the instruction (such as the test-and-skip instructions) or the clocking mode (Compatible or Turbo). In those cases, all possible numbers of cycles are shown in the table.

The instruction execution time is derived by dividing the oscillator frequency by either one (Turbo mode) or four (Compatible mode). The divide-by factor is selected through the FUSE Word register.

Table 16-1. The SX Instruction Set

Mnemonic, Operands	Description	Cycles (Compatible)	Cycles (Turbo)	Opcode	Bits Affected
Logical Operations					
AND fr, W	AND of fr and W into fr ($fr = fr \& W$)	1	1	0001 011f ffff	Z
AND W, fr	AND of W and fr into W ($W = W \& fr$)	1	1	0001 010f ffff	Z
AND W, #lit	AND of W and Literal into W ($W = W \& lit$)	1	1	1110 kkkk kkkk	Z
NOT fr	Complement of fr into fr ($fr = fr \wedge FFh$)	1	1	0010 011f ffff	Z
OR fr, W	OR of fr and W into fr ($fr = fr W$)	1	1	0001 001f ffff	Z
OR W, fr	OR of W and fr into W ($W = W fr$)	1	1	0001 000f ffff	Z
OR W, #lit	OR of W and Literal into W ($W = W lit$)	1	1	1101 kkkk kkkk	Z
XOR fr, W	XOR of fr and W into fr ($fr = fr \wedge W$)	1	1	0001 101f ffff	Z
XOR W, fr	XOR of W and fr into W ($W = W \wedge fr$)	1	1	0001 100f ffff	Z
XOR W, #lit	XOR of W and Literal into W ($W = W \wedge lit$)	1	1	1111 kkkk kkkk	Z
Arithmetic and Shift Operations					
ADD fr, W	Add W to fr ($fr = fr + W$); carry bit is added if \overline{CF} bit in FUSEX register is cleared to 0	1	1	0001 111f ffff	C, DC, Z
ADD W, fr	Add fr to W ($W = W + fr$); carry bit is added if \overline{CF} bit in FUSEX register is cleared to 0	1	1	0001 110f ffff	C, DC, Z
CLR fr	Clear fr ($fr = 0$)	1	1	0000 011f ffff	Z
CLR W	Clear W ($W = 0$)	1	1	0000 0100 0000	Z
CLR !WDT	Clear Watchdog Timer, clear prescaler if assigned to the Watchdog ($TO = 1, PD = 1$)	1	1	0000 0000 0100	TO, PD
DEC fr	Decrement fr ($fr = fr - 1$)	1	1	0000 111f ffff	Z
DECSZ fr	Decrement fr and Skip if Zero ($fr = fr - 1$ and skip next instruction if result is zero)	1 or 2 (skip)	1 or 2 (skip)	0010 111f ffff	none
INC fr	Increment fr ($fr = fr + 1$)	1	1	0010 101f ffff	Z
INCSZ fr	Increment fr and Skip if Zero ($fr = fr + 1$ and skip next instruction if result is zero)	1 or 2 (skip)	1 or 2 (skip)	0011 111f ffff	none
RL fr	Rotate fr Left through Carry ($fr = \ll fr$)	1	1	0011 011f ffff	C
RR fr	Rotate fr Right through Carry ($fr = \gg fr$)	1	1	0011 001f ffff	C
SUB fr, W	Subtract W from fr ($fr = fr - W$); complement of the carry bit is subtracted if CF bit in FUSEX register is cleared to 0	1	1	0000 101f ffff	C, DC, Z
SWAP fr	Swap High/Low Nibbles of fr ($fr = \ll\> fr$)	1	1	0011 101f ffff	none

Table 16-1. The SX Instruction Set (Continued)

Mnemonic, Operands	Description	Cycles (Compatible)	Cycles (Turbo)	Opcode	Bits Affected
Bitwise Operations					
CLRB fr.bit	Clear Bit in fr (fr.bit = 0)	1	1	0100 bbbf ffff	none
SB fr.bit	Test Bit in fr and Skip if Set (test fr.bit and skip next instruction if bit is 1)	1 or 2 (skip)	1 or 2 (skip)	0111 bbbf ffff	none
SETB fr.bit	Set Bit in fr (fr.bit = 1)	1	1	0101 bbbf ffff	none
SNB fr.bit	Test Bit in fr and Skip if Clear (test fr.bit and skip next instruction if bit is 0)	1 or 2 (skip)	1 or 2 (skip)	0110 bbbf ffff	none
Data Movement Instructions					
MOV fr,W	Move W to fr (fr = W)	1	1	0000 001f ffff	none
MOV W,fr	Move fr to W (W = fr)	1	1	0010 000f ffff	Z
MOV W,fr-W	Move (fr-W) to W (W = fr - W); complement of carry bit is subtracted if CF bit in FUSEX register is cleared to 0	1	1	0000 100f ffff	C, DC, Z
MOV W,#lit	Move Literal to W (W = lit)	1	1	1100 kkkk kkkk	none
MOV W,/fr	Move Complement of fr to W (W = fr ^ FFh)	1	1	0010 010f ffff	Z
MOV W,--fr	Move (fr-1) to W (W = fr - 1)	1	1	0000 110f ffff	Z
MOV W,++fr	Move (fr+1) to W (W = fr + 1)	1	1	0010 100f ffff	Z
MOV W,<<fr	Rotate fr Left through Carry and Move to W (W = << fr)	1	1	0011 010f ffff	C
MOV W,>>fr	Rotate fr Right through Carry and Move to W (W = >> fr)	1	1	0011 000f ffff	C
MOV W,<>fr	Swap High/Low Nibbles of fr and move to W (W = <> fr)	1	1	0011 100f ffff	none
MOV W,M	Move MODE Register to W (W = MODE), high nibble is cleared	1	1	0000 0100 0010	none
MOVSZ W,--fr	Move (fr-1) to W and Skip if Zero (W = fr - 1 and skip next instruction if result is zero)	1 or 2 (skip)	1 or 2 (skip)	0010 110f ffff	none
MOVSZ W,++fr	Move (fr+1) to W and Skip if Zero (W = fr + 1 and skip next instruction if result is zero)	1 or 2 (skip)	1 or 2 (skip)	0011 110f ffff	none
MOV M,W	Move W to MODE Register (MODE = W)	1	1	0000 0100 0011	none
MOV M,#lit	Move Literal to MODE Register (MODE = lit)	1	1	0000 0101 kkkk	none
MOV !rx,W	Move W to Port Rx Control Register:rx <=> W (exchange W and WKPND_B or CMP_B) or rx = W (move W to rx for all other port control registers)	1	1	0000 0000 0fff	none
MOV !OPTION, W	Move W to OPTION Register (OPTION = W)	1	1	0000 0000 0010	none
TEST fr	Test fr for Zero (fr = fr to set or clear Z bit)	1	1	0010 001f ffff	Z

Table 16-1. The SX Instruction Set (Continued)

Mnemonic, Operands	Description	Cycles (Compatible)	Cycles (Turbo)	Opcode	Bits Affected
Program Control instruction					
CALL addr8	Call Subroutine: top-of-stack = program counter + 1 PC(7:0) = addr8 program counter (8) = 0 program counter (10:9) = PA1:PA0	2	3	1001 kkkk kkkk	none
JMP addr9	Jump to Address: PC(7:0) = addr9(7:0) program counter (8) = addr9(8) program counter (10:9) = PA1:PA0	2	3	101k kkkk kkkk	none
NOP	No Operation	1	1	0000 0000 0000	none
RET	Return from Subroutine (program counter = top-of-stack)	2	3	0000 0000 1100	none
RETP	Return from Subroutine Across Page Boundary (PA1:PA0 = top-of-stack (10:9) and program counter = top-of-stack)	2	3	0000 0000 1101	PA1, PA0
RETI	Return from Interrupt (restore W, STATUS, FSR, and program counter from shadow registers)	2	3	0000 0000 1110	all STATUS, except TO, PD
RETIW	Return from Interrupt and add W to RTCC (restore W, STATUS, FSR, and program counter from shadow registers; and add W to RTCC)	2	3	0000 0000 1111	all STATUS, except TO, PD
RETW lit	Return from Subroutine with Literal in W (W = lit and program counter = top-of-stack)	2	3	1000 kkkk kkkk	none
System Control Instructions					
BANK addr8	Load Bank Number into FSR(7:5) FSR(7:5) = addr8(7:5)	1	1	0000 0001 1nnn	none
IREAD	Read Word from Instruction Memory MODE:W = data at (MODE:W)	1	4	0000 0100 0001	none
PAGE addr12	Load Page Number into STATUS(7:5) STATUS(7:5) = addr12(11:9)	1	1	0000 0001 0nnn	PA1, PA0
SLEEP	Power Down Mode WDT = 00h, TO = 1, stop oscillator (PD = 0, clears prescaler if assigned)	1	1	0000 0000 0011	TO, PD

16.1 Equivalent Assembler Mnemonics

Some assemblers support additional instruction mnemonics that are special cases of existing instructions or alternative mnemonics for standard ones. For example, an assembler might support the mnemonic "CLC" (clear

carry), which is interpreted the same as the instruction "clrb \$03.0" (clear bit 0 in the STATUS register). Some of the commonly supported equivalent assembler mnemonics are described in Table 16-2.

Table 16-2. Equivalent Assembler Mnemonics

Syntax	Description	Equivalent	Cycles
CLC	Clear Carry bit	CLRB \$03.0	1
CLZ	Clear Zero bit	CLRB \$03.2	1
JMP W	Jump Indirect W	MOV \$02,W	4 or 3 (note 1)
JMP PC+W	Jump Indirect W Relative	ADD \$02,W	4 or 3 (note 1)
MODE imm4	Move Immediate to MODE Register	MOV M,#lit	1
NOT W	Complement W	XOR W,\$FF	1
SC	Skip if Carry bit Set	SB \$03.0	1 or 2 (note 2)
SKIP	Skip Next Instruction	SNB \$02.0 or SB \$02.0	4 or 2 (note 3)

Note 1: The JMP W or JMP PC+W instruction takes 4 cycles in the "compatible" clocking mode or 3 cycles in the "turbo" clocking mode.

Note 2: The SC instruction takes 1 cycle if the tested condition is false or 2 cycles if the tested condition is true.

Note 3: The assembler converts the SKIP instruction into a SNB or SB instruction that tests the least significant bit of the program counter, choosing SNB or SB so that the tested condition is always true. The instruction takes 4 cycles in the "compatible" clocking mode or 2 cycles in the "turbo" clocking mode.

17.0 ELECTRICAL CHARACTERISTICS

17.1 Absolute Maximum Ratings

Ambient temperature under bias	-40°C to +85°C
Storage temperature	-65°C to +150°C
Voltage on V_{dd} with respect to V_{ss}	0 V to +7.0V
Voltage on OSC1 with respect to V_{ss}	0 V to +13.5V
Voltage on \overline{MCLR} with respect to V_{ss}	0 V to +13.5V
Voltage on all other pins with respect to V_{ss}	-0.6 V to ($V_{dd} + 0.6V$)V
Total power dissipation	700 mW
Max. current out of V_{ss} pin	130 mA
Max. current into V_{dd} pin	130 mA
Max. DC current into an input pin (with internal protection diode forward biased)	$\pm 500 \mu A$
Max. allowable sink current per I/O pin	45 mA
Max. allowable source current per I/O pin	45 mA

17.2 DC Characteristics

SX20/28AC at 75MHz(Temp Range: 0°C ≤ Ta ≤ +70°C)

SX20/28AC at 50MHz (Temp Range: -40°C ≤ Ta ≤ +85°C)

Symbol	Parameter	Conditions	Min	Typ	Max	Units
V _{dd}	Supply Voltage (Note 1)	F _{osc} = 32 MHz	2.7	-	5.5	V
		F _{osc} = 50 MHz	3.0	-	5.5	V
		F _{osc} = 75 MHz	4.5	-	5.5	V
S _{Vdd}	V _{dd} rise rate (Note 1)		0.05	-	-	V/ms
I _{dd}	Supply Current, active	V _{dd} = 5.0V, F _{osc} = 75 MHz (External OSC)	-	100	105	mA
		V _{dd} = 5.0V, F _{osc} = 50 MHz (Crystal)	-	77	82	mA
		V _{dd} = 5.0V, F _{osc} = 4 MHz (Crystal)	-	7.5	8	mA
		V _{dd} = 2.7V, F _{osc} = 20 MHz (Crystal)	-	17	18	mA
I _{pd}	Supply Current, power down	V _{dd} = 3.0V, WDT enabled (before timeout)	-	10	20	μA
		V _{dd} = 3.0V, WDT disabled		1.0	9.0	μA
		V _{dd} = 4.5V, WDT enabled			110	μA
		V _{dd} = 4.5V, WDT disabled			100	μA
V _{ih} , V _{il}	Input Levels					
	MCLR, OSC1, RTCC					
	Logic High		0.8V _{dd}		V _{dd}	V
	Logic Low		V _{ss}		0.2V _{dd}	V
	All Other Inputs					
	CMOS					
Logic High		0.7V _{dd}		V _{dd}	V	
Logic Low		V _{ss}		0.3V _{dd}	V	
TTL						
Logic High		2.0		V _{dd}	V	
Logic Low		V _{ss}		0.8	V	
I _{il}	Input Leakage Current	V _{in} = V _{dd} or V _{ss}	-1.0		+1.0	μA
I _{ip}	Weak Pullup Current	V _{dd} = 5.5V, V _{in} = 0V	100		190	μA
		V _{dd} = 3.0V, V _{in} = 0V	25		50	μA
V _{oh}	Output High Voltage Ports B, C	I _{oh} = 20mA, V _{dd} = 4.5V				V
		I _{oh} = 12mA, V _{dd} = 3.0V				V
	Port A	I _{oh} = 30mA, V _{dd} = 4.5				V
		I _{oh} = 20mA, V _{dd} = 3.0V				V
V _{ol}	Output Low Voltage All Ports	I _{ol} = 30mA, V _{dd} = 4.5V			0.6	V
		I _{ol} = 20mA, V _{dd} = 3.0V			0.6	V

Note 1: V_{dd} must start rising from V_{ss} to ensure proper Power-On-Reset when relying on the internal Power-On-Reset circuitry.

17.3 AC Characteristics

SX20/28AC at 75MHz(Temp Range: 0°C ≤ Ta ≤ +70°C)

SX20/28AC at 50MHz (Temp Range: -40°C ≤ Ta ≤ +85°C)

Symbol	Parameter	Min	Typ	Max	Units	Conditions
F _{osc}	External CLKIN Frequency	DC	-	32	KHz	LP1
				1.0	MHz	LP2
				4.0	MHz	RC
				10	MHz	XT1
				24	MHz	XT2
				50	MHz	HS1/HS2/HS3
				75	MHz	HS3
	Oscillator Frequency	DC	-	32	KHz	LP1
		0.032		1.0	MHz	LP2
		DC		4.0	MHz	RC
		0.032		10.0	MHz	XT1
		1.0		24.0	MHz	XT2
		1.0		50	MHz	HS1/HS2/HS3
		1.0		75	MHz	HS3
T _{osc}	External CLKIN Period	31.25	-	-	μs	LP1
		1.0			μs	LP2
		250			ns	RC
		100			ns	XT1
		41.7			ns	XT2
		20			ns	HS1/HS2/HS3
		13.3			ns	
	Oscillator Period	31.25	-	-	μs	LP1
		1.0		31.25	μs	LP2
		250		-	μs	RC
		0.1		31.25	μs	XT1
		41.7		1000.0	ns	XT2
		20		1000.0	ns	HS1/HS2/HS3
		13.3		-	ns	HS3
T _{osL} , T _{osH}	Clock in (OSC1) Low or High Time	2.0	-	-	μs	LP1/LP2
		50			ns	XT1/XT2
		8.0			ns	HS1/HS2/HS3
		5.3			ns	HS3
					ns	

Note: Data in the Typical ("TYP") column is at 25°C unless otherwise stated.

17.4 Comparator DC and AC Specifications (50 MHz and 75 MHz Operation)

Parameter	Conditions	Min	Typ	Max	Units
Input Offset Voltage	0.4V < Vin < Vdd - 1.5V		+/- 10	+/- 25	mV
Input Common Mode Voltage Range		0.4		Vcc - 1.3	V
Voltage Gain			300k		V/V
DC Supply Current (enabled)	Vdd = 5.5V			120	μA
Response Time	V _{overdrive} = 25mV			250	ns

17.5 Typical Performance Characteristics (25°C)

Active Supply Current Vs Operating Frequency
(Crystal Clock)

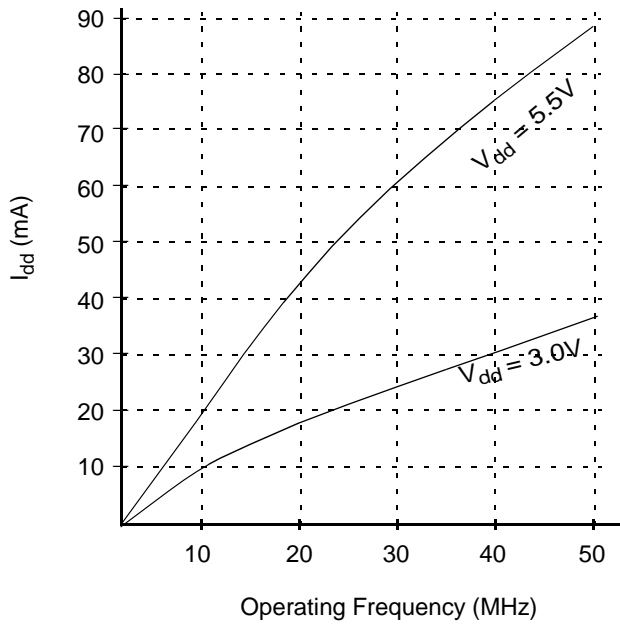

Active Supply Current Vs Operating Frequency
(External Clock)

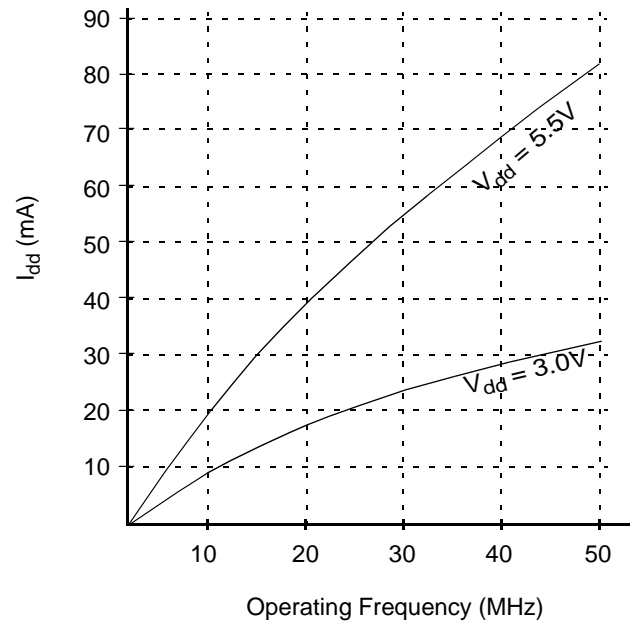

17.7 Typical Performance Characteristics (Continued)

Active Supply Current Vs Operating Frequency
(External Clock)

SX18AC75/SX20AC75/SX28AC75

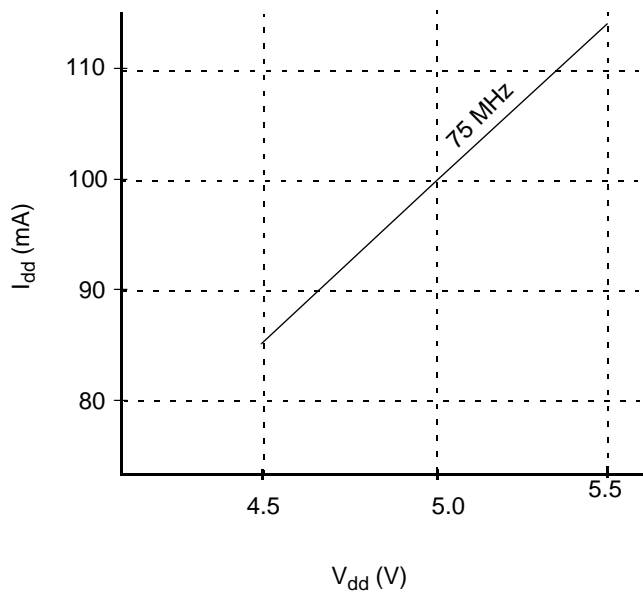

Active Supply Current Vs V_{dd}
(Crystal Clock)

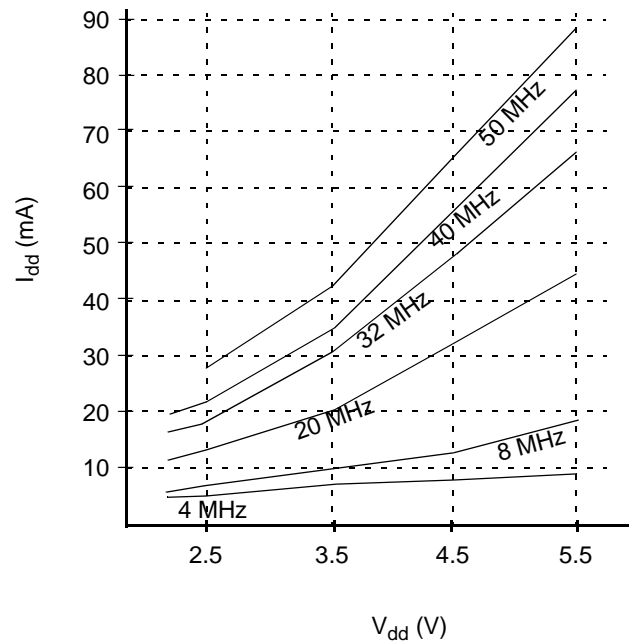

Active Supply Current Vs V_{dd}
(External Clock)

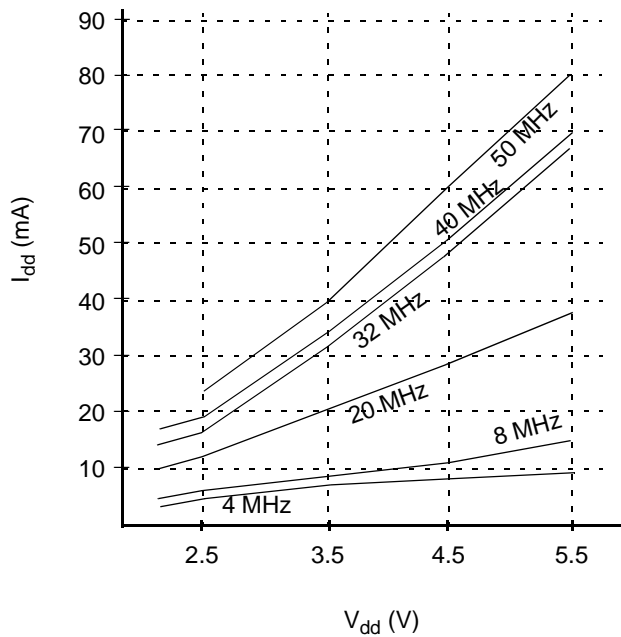

Active Supply Current Vs V_{dd}
(32 kHz Crystal Clock)

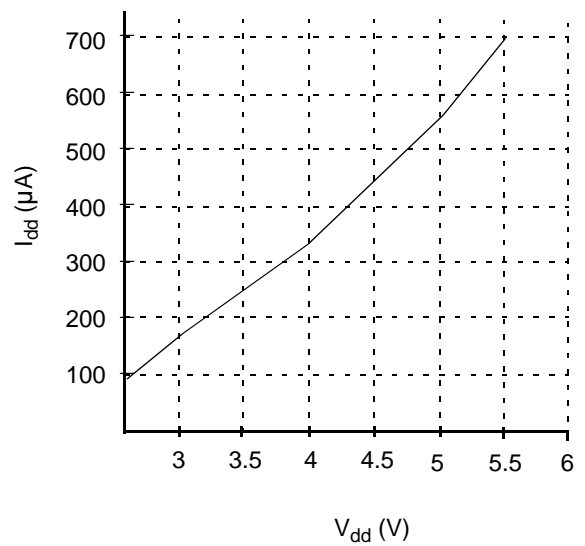

17.7 Typical Performance Characteristics (25°C)

Active Supply Current Vs V_{dd}
(32 kHz External Clock)

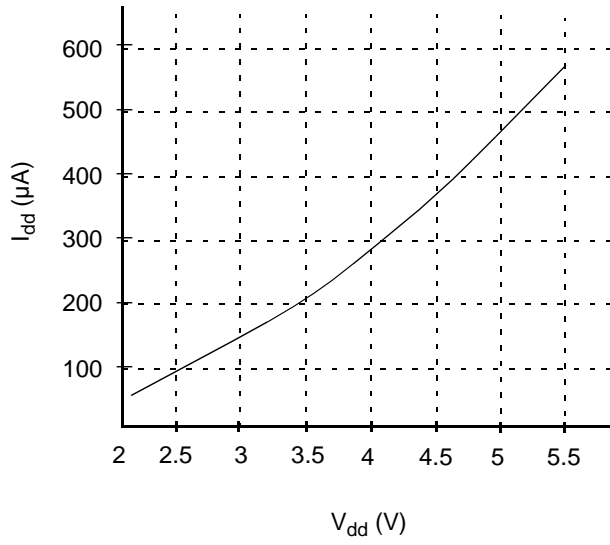

Port A/B/C Weak Pull-Up Source Current

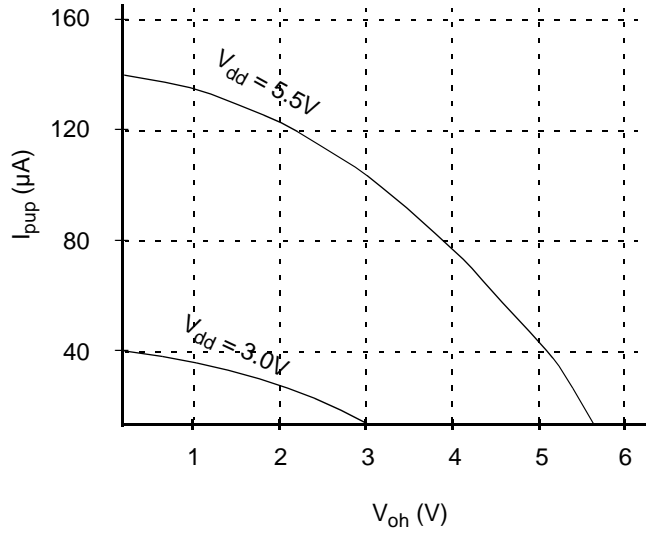

Port A/B/C Source Current

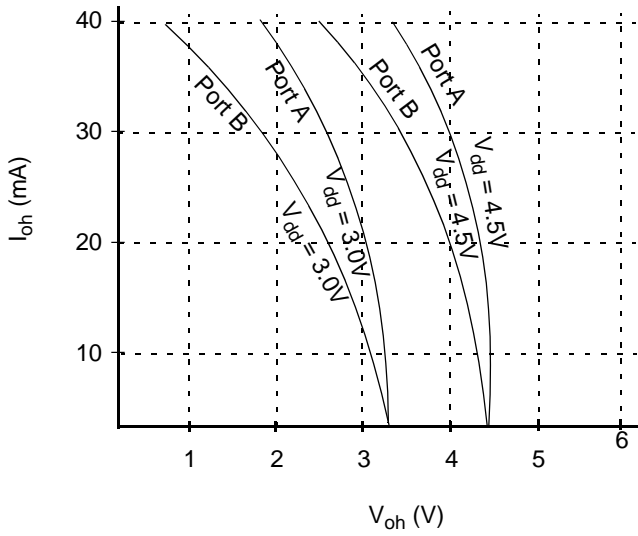

Port A/B/C Sink Current

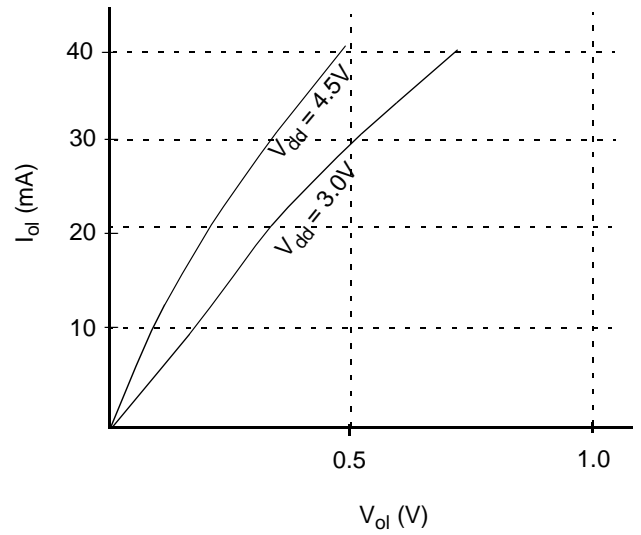

18.0 PACKAGE DIMENSIONS (DIMENSIONS ARE IN INCHES/(MILLIMETERS))

SX20AC/SS

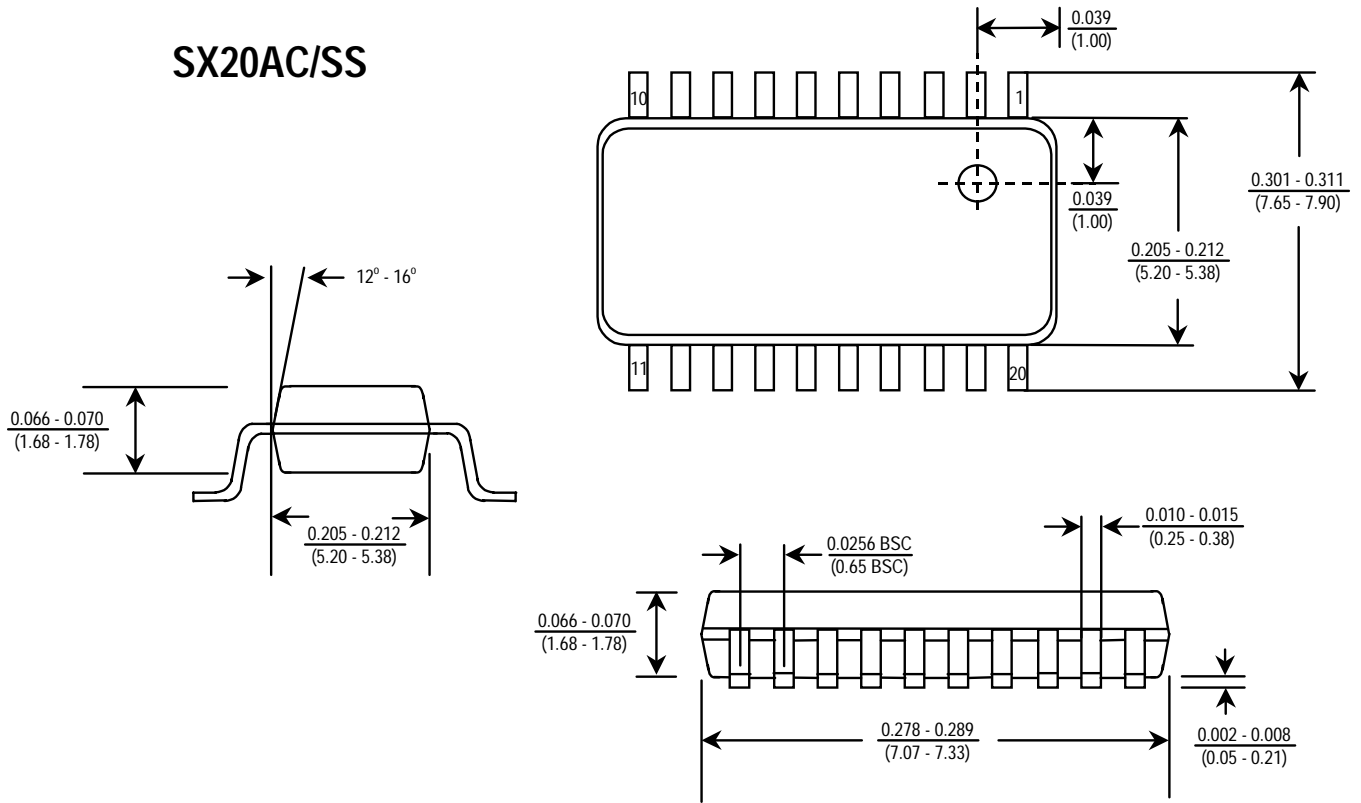

SX28AC/SS

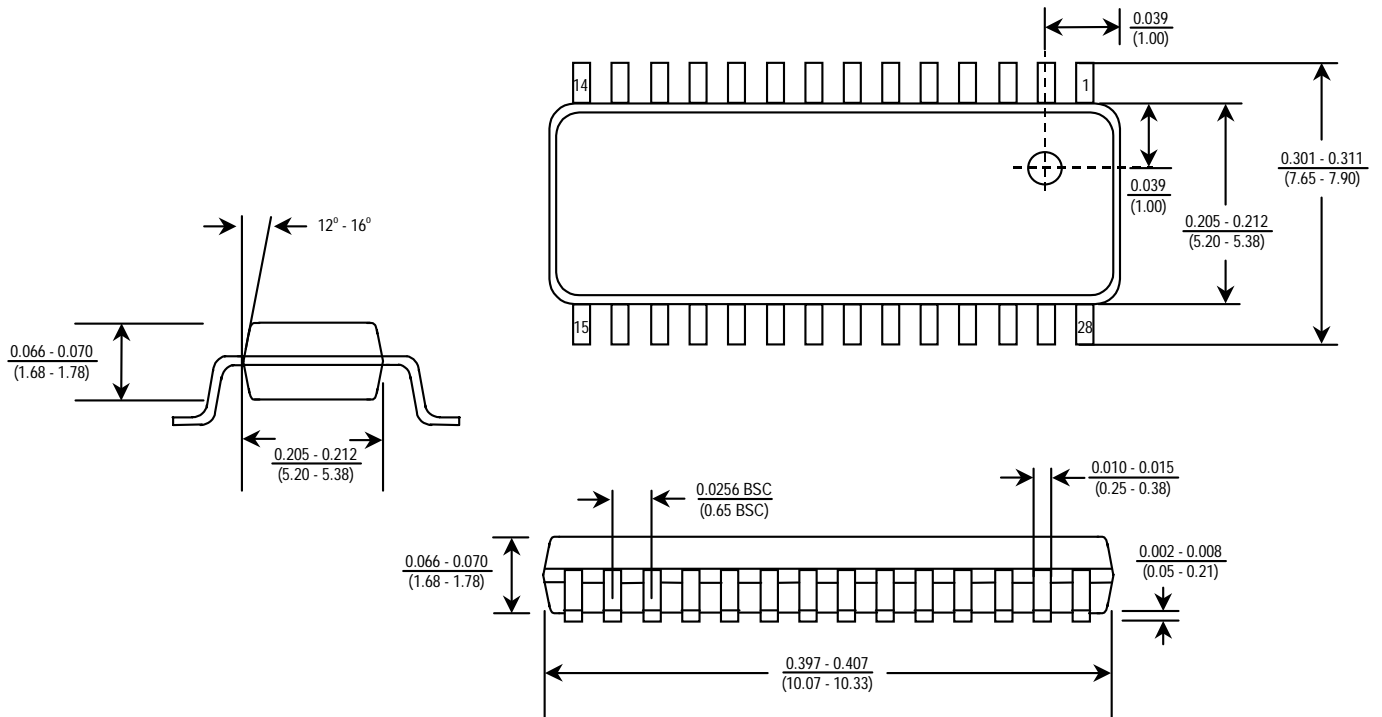

SX28AC/DP

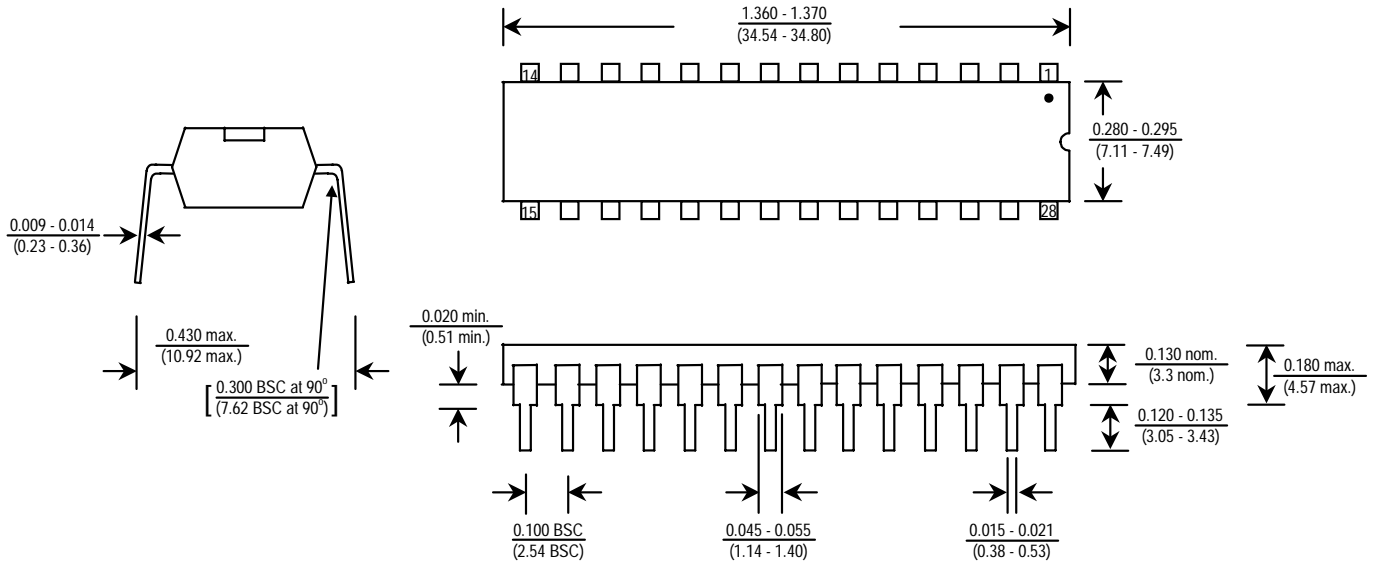

Lit #: SX-DDS-SX2028AC-16

Sales and Tech Support Contact Information

For the latest contact and support information on SX devices, please visit the Ubicom website at www.ubicom.com. The site contains technical literature, local sales contacts, tech support and many other features.



635 Clyde Avenue
Mountain View, CA 94043
E-Mail: sales@ubicom.com
Web site: www.ubicom.com
Tel.: (650) 210-1500
Fax: (650) 210-8715

Looking for pricing, stock, or lifecycle information?

Click below to explore more details on WIN SOURCE:

 [View SX28AC/SS on WIN SOURCE](#)

 [Parallax Inc. Information](#)

Optimize Your Supply Chain with WIN SOURCE Solutions

-  Global Sourcing Solution
-  Obsolete Management
-  Cost Control Management
-  Shortage Management
-  Alternative Solution
-  Excess Inventory Management