



# THE DATASHEET OF SPC5605BK0MLL6





# MPC5606BK



100 LQFP  
14 mm x 14 mm



144 LQFP  
20 mm x 20 mm

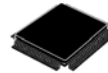

176 LQFP  
24 mm x 24 mm

## MPC5606BK Microcontroller Data Sheet

### 1 Introduction

#### 1.1 Document overview

This document describes the features of the family and options available within the family members, and highlights important electrical and physical characteristics of the device.

#### 1.2 Description

This family of 32-bit system-on-chip (SoC) microcontrollers is the latest achievement in integrated automotive application controllers. It belongs to an expanding family of automotive-focused products designed to address the next wave of body electronics applications within the vehicle.

The advanced and cost-efficient e200z0 host processor core of this automotive controller family complies with the Power Architecture® technology and only implements the VLE (variable-length encoding) APU (Auxiliary Processor Unit), providing improved code density. It operates at speeds of up to 64 MHz and offers high performance processing optimized for low power consumption. It capitalizes on the available development infrastructure of current Power Architecture devices and is supported with software drivers, operating systems and configuration code to assist with users implementations.

1	Introduction	1
1.1	Document overview	1
1.2	Description	1
1.3	Device comparison	2
1.4	Block diagram	3
2	Package pinouts and signal descriptions	4
2.1	Package pinouts	4
2.2	Pin muxing	7
3	Electrical characteristics	25
3.1	Parameter classification	25
3.2	NVUSRO register	26
3.3	Absolute maximum ratings	27
3.4	Recommended operating conditions	28
3.5	Thermal characteristics	31
3.6	I/O pad electrical characteristics	33
3.7	RESET electrical characteristics	45
3.8	Power management electrical characteristics	48
3.9	Power consumption in different application modes	53
3.10	Flash memory electrical characteristics	54
3.11	Electromagnetic compatibility (EMC) characteristics	56
3.12	Fast external crystal oscillator (4 to 16 MHz) electrical characteristics	58
3.13	Slow external crystal oscillator (32 kHz) electrical characteristics	61
3.14	FMPLL electrical characteristics	63
3.15	Fast internal RC oscillator (16 MHz) electrical characteristics	64
3.16	Slow internal RC oscillator (128 kHz) electrical characteristics	65
3.17	ADC electrical characteristics	66
3.18	On-chip peripherals	76
4	Package characteristics	85
4.1	Package mechanical data	85
5	Ordering information	93
6	Revision history	94



## 1.3 Device comparison

Table 1 summarizes the functions of the blocks present on the MPC5606BK.

**Table 1. MPC5606BK family comparison<sup>1</sup>**

Feature	MPC5605BK			MPC5606BK		
	100 LQFP	144 LQFP	176 LQFP	100 LQFP	144 LQFP	176 LQFP
CPU	e200z0h					
Execution speed <sup>2</sup>	Up to 64 MHz					
Code flash memory	768 KB			1 MB		
Data flash memory	64 (4 x 16) KB					
SRAM	64 KB			80 KB		
MPU	8-entry					
eDMA	16 ch					
10-bit ADC	Yes					
dedicated <sup>3</sup>	7 ch	15 ch	29 ch	7 ch	15 ch	29 ch
shared with 12-bit ADC	19 ch					
12-bit ADC	Yes					
dedicated <sup>4</sup>	5 ch					
shared with 10-bit ADC	19 ch					
Total timer I/O <sup>5</sup> eMIOS	37 ch, 16-bit	64 ch, 16-bit		37 ch, 16-bit	64 ch, 16-bit	
Counter / OPWM / ICOC <sup>6</sup>	10 ch					
O(I)PWM / OPWFMB / OPWMCB / ICOC <sup>7</sup>	7 ch					
O(I)PWM / ICOC <sup>8</sup>	7 ch	14 ch				
OPWM / ICOC <sup>9</sup>	13 ch	33 ch				
SCI (LINFlex)	4	6	8	4	6	8
SPI (DSPI)	3	5	6	3	5	6
CAN (FlexCAN)	6					
I <sup>2</sup> C	1					
32 KHz oscillator	Yes					
GPIO <sup>10</sup>	77	121	149	77	121	149
Debug	JTAG					

<sup>1</sup> Feature set dependent on selected peripheral multiplexing; table shows example.

<sup>2</sup> Based on 125 °C ambient operating temperature.

<sup>3</sup> Not shared with 12-bit ADC, but possibly shared with other alternate functions.

<sup>4</sup> Not shared with 10-bit ADC, but possibly shared with other alternate functions.

<sup>5</sup> Refer to eMIOS section of device reference manual for information on the channel configuration and functions.

<sup>6</sup> Each channel supports a range of modes including Modulus counters, PWM generation, Input Capture, Output Compare.

<sup>7</sup> Each channel supports a range of modes including PWM generation with dead time, Input Capture, Output Compare.

<sup>8</sup> Each channel supports a range of modes including PWM generation, Input Capture, Output Compare, Period and Pulse width measurement.

<sup>9</sup> Each channel supports a range of modes including PWM generation, Input Capture, and Output Compare.

<sup>10</sup> Maximum I/O count based on multiplexing with peripherals.

# 1.4 Block diagram

Figure 1 shows a top-level block diagram of the MPC5606BK.

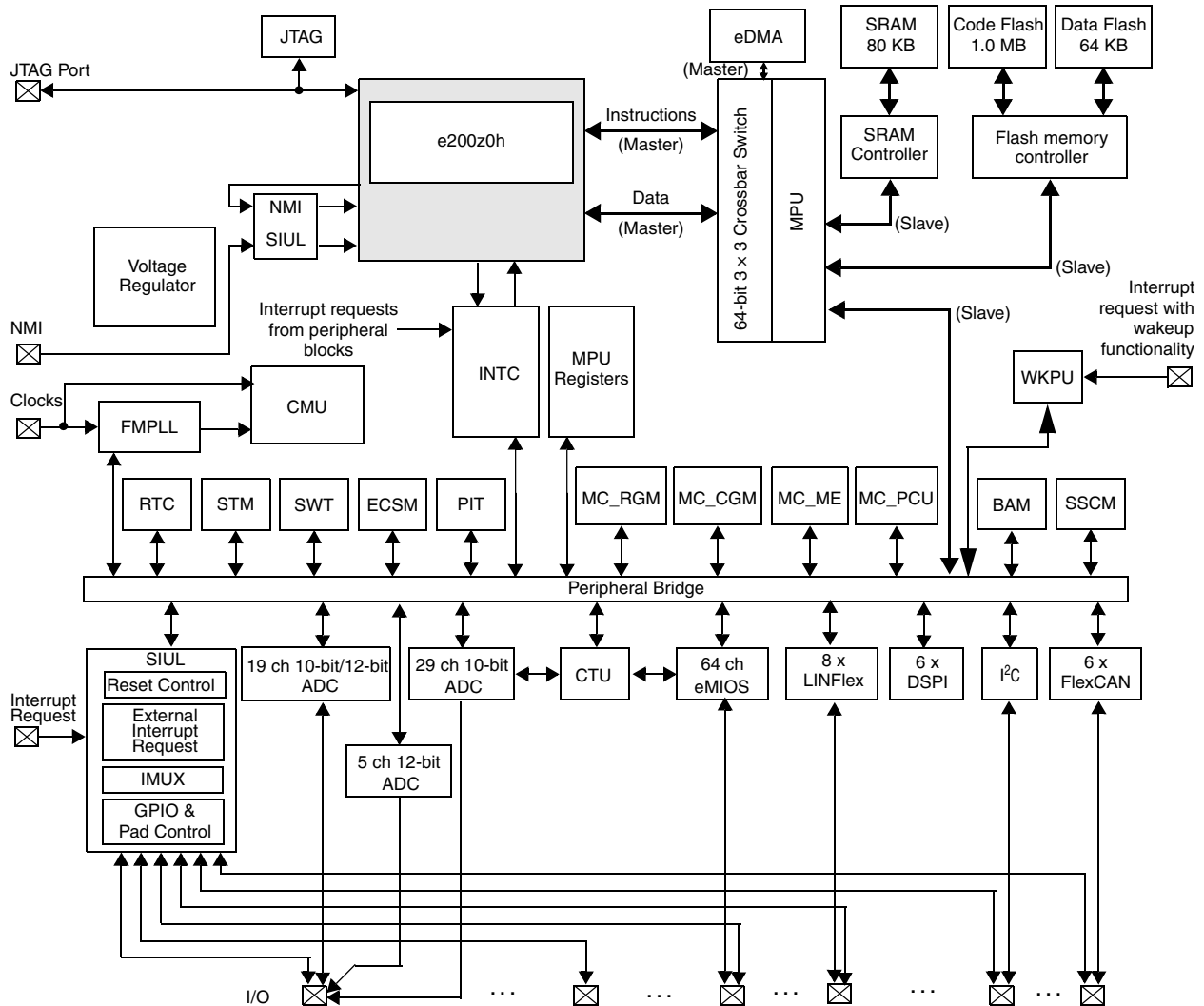

Legend:

ADC	Analog-to-Digital Converter	LINFlex	Serial Communication Interface (LIN support)
BAM	Boot Assist Module	MC_CGM	Clock Generation Module
FlexCAN	Controller Area Network	MC_ME	Mode Entry Module
CFlash	Code flash memory	MPU	Memory Protection Unit
CMU	Clock Monitor Unit	NMI	Non-Maskable Interrupt
CTU	Cross Triggering Unit	MC_PCU	Power Control Unit
DFlash	Data flash memory	MC_RGM	Reset Generation Module
DSPI	Deserial Serial Peripheral Interface	PIT	Periodic Interrupt Timer
eDMA	Enhanced Direct Memory Access	RTC	Real-Time Clock
eMIOS	Enhanced Modular Input Output System	SIUL	System Integration Unit Lite
FMPLL	Frequency-Modulated Phase-Locked Loop	SRAM	Static Random-Access Memory
I2C	Inter-integrated Circuit Bus	SSCM	System Status Configuration Module
IMUX	Internal Multiplexer	STM	System Timer Module
INTC	Interrupt Controller	SWT	Software Watchdog Timer
JTAG	JTAG controller	WKPU	Wakeup Unit

Figure 1. MPC5606BK block diagram

## 2 Package pinouts and signal descriptions

### 2.1 Package pinouts

The available LQFP pinouts are provided in the following figures. For pin signal descriptions, please see [Table 2](#).

[Figure 2](#) shows the MPC5606BK in the 176 LQFP package.

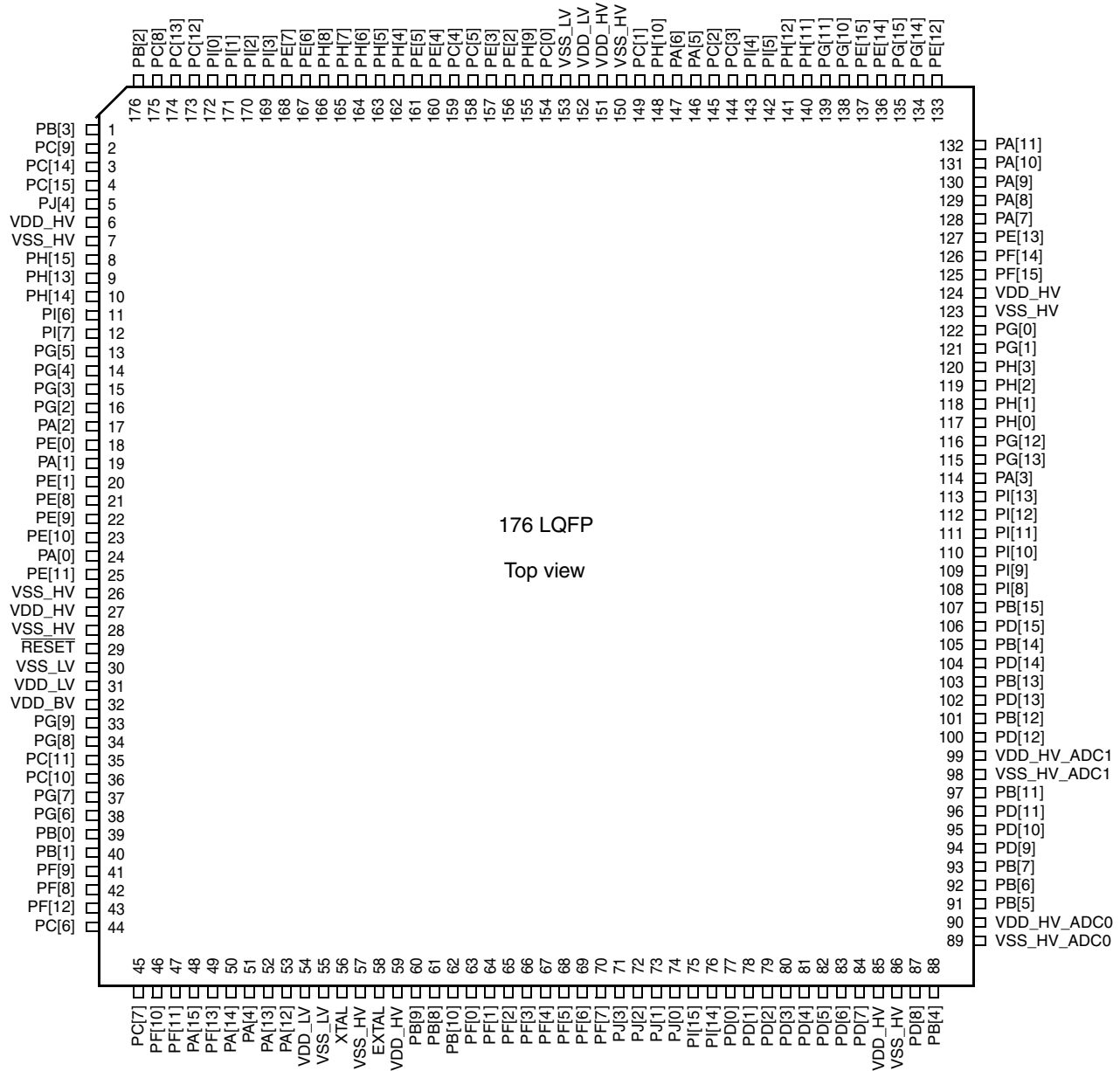

Figure 2. 176 LQFP pinout

Figure 3 shows the MPC5606BK in the 144 LQFP package.

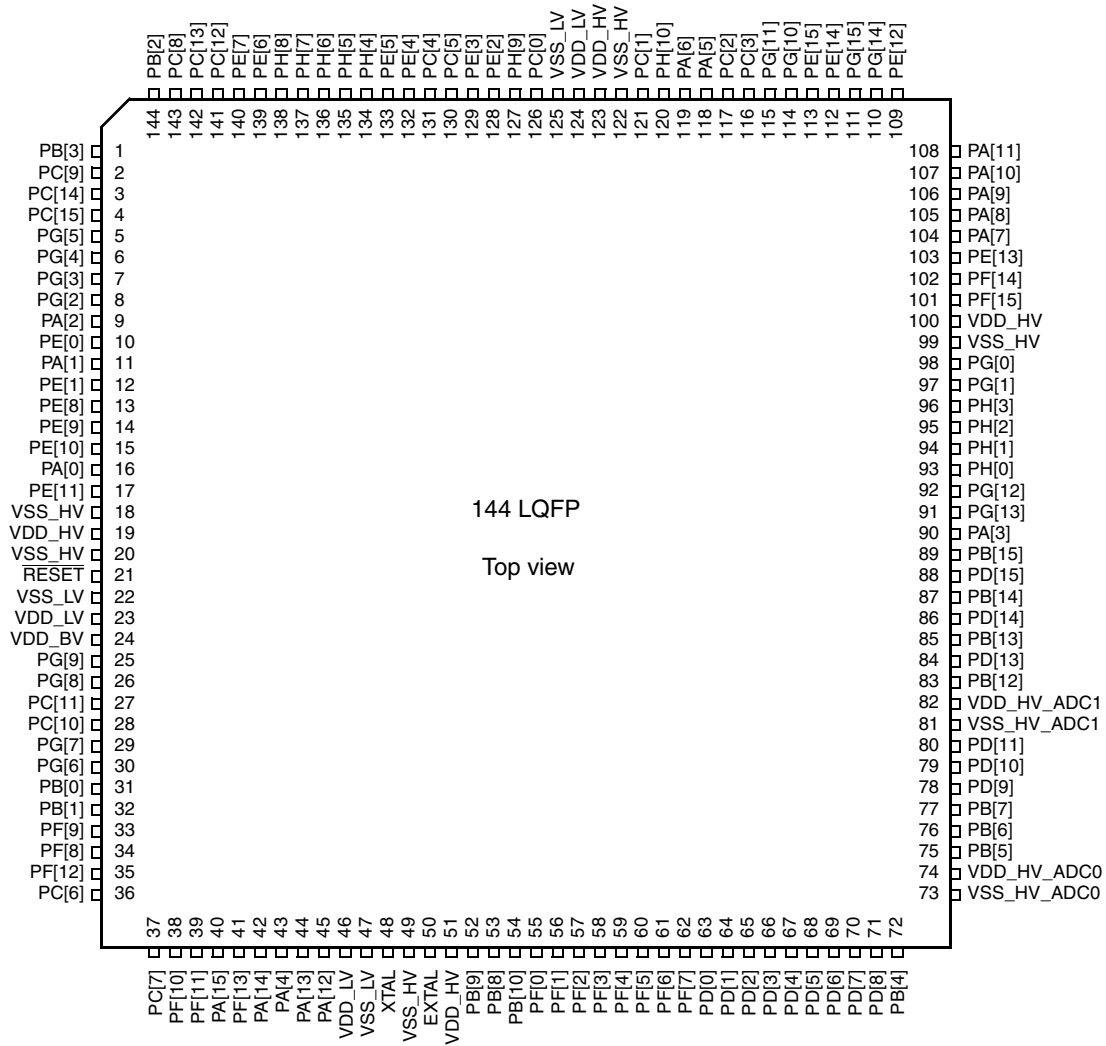

Figure 3. 144 LQFP pinout

Figure 4 shows the MPC5606BK in the 100 LQFP package.

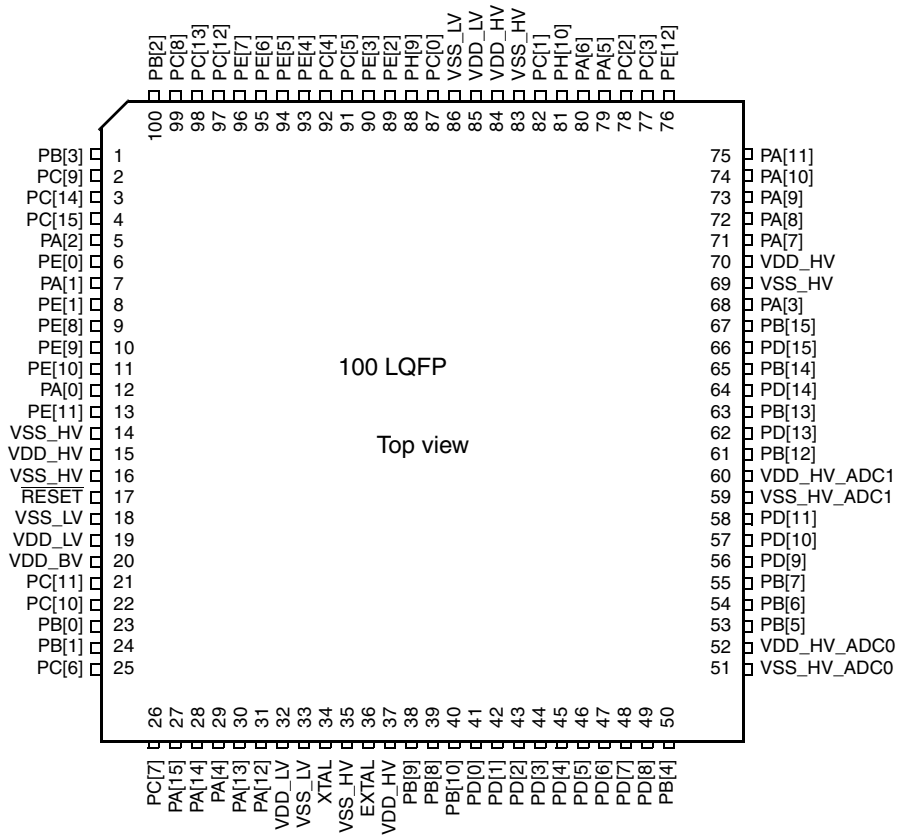

Figure 4. 100 LQFP pinout

## 2.2 Pin muxing

Table 2 defines the pin list and muxing for this device.

Each entry of Table 2 shows all the possible configurations for each pin, via the alternate functions. The default function assigned to each pin after reset is indicated by AF0.

**Table 2. Functional port pins**

Port pin	PCR register	Alternate function <sup>1</sup>	Function	Peripheral	I/O direction	Pad type <sup>2</sup>	RESET config. <sup>3</sup>	Pin number		
								100 LQFP	144 LQFP	176 LQFP
<b>Port A</b>										
PA[0]	PCR[0]	AF0 AF1 AF2 AF3 —	GPIO[0] E0UC[0] CLKOUT E0UC[13] WKUP[19] <sup>4</sup>	SIUL eMIOS_0 MC_CGM eMIOS_0 WKUP	I/O I/O O I/O I	M	Tristate	12	16	24
PA[1]	PCR[1]	AF0 AF1 AF2 AF3 —	GPIO[1] E0UC[1] NMI <sup>5</sup> — WKUP[2] <sup>4</sup>	SIUL eMIOS_0 WKUP — WKUP	I/O I/O I — I	S	Tristate	7	11	19
PA[2]	PCR[2]	AF0 AF1 AF2 AF3 —	GPIO[2] E0UC[2] — MA[2] WKUP[3] <sup>4</sup>	SIUL eMIOS_0 — ADC_0 WKUP	I/O I/O — O I	S	Tristate	5	9	17
PA[3]	PCR[3]	AF0 AF1 AF2 AF3 — —	GPIO[3] E0UC[3] LIN5TX CS4_1 EIRQ[0] ADC1_S[0]	SIUL eMIOS_0 LINFlex_5 DSPI_1 SIUL ADC_1	I/O I/O O O I I	J	Tristate	68	90	114
PA[4]	PCR[4]	AF0 AF1 AF2 AF3 — —	GPIO[4] E0UC[4] — CS0_1 LIN5RX WKUP[9] <sup>4</sup>	SIUL eMIOS_0 — DSPI_1 LINFlex_5 WKUP	I/O I/O — I/O I I	S	Tristate	29	43	51
PA[5]	PCR[5]	AF0 AF1 AF2 AF3	GPIO[5] E0UC[5] LIN4TX —	SIUL eMIOS_0 LINFlex_4 —	I/O I/O O —	M	Tristate	79	118	146
PA[6]	PCR[6]	AF0 AF1 AF2 AF3 — —	GPIO[6] E0UC[6] — CS1_1 EIRQ[1] LIN4RX	SIUL eMIOS_0 — DSPI_1 SIUL LINFlex_4	I/O I/O — O I I	S	Tristate	80	119	147

**Table 2. Functional port pins (continued)**

Port pin	PCR register	Alternate function <sup>1</sup>	Function	Peripheral	I/O direction	Pad type <sup>2</sup>	RESET config. <sup>3</sup>	Pin number		
								100 LQFP	144 LQFP	176 LQFP
PA[7]	PCR[7]	AF0 AF1 AF2 AF3 — —	GPIO[7] E0UC[7] LIN3TX — EIRQ[2] ADC1_S[1]	SIUL eMIOS_0 LINFlex_3 — SIUL ADC_1	I/O I/O O — I I	J	Tristate	71	104	128
PA[8]	PCR[8]	AF0 AF1 AF2 AF3 — N/A <sup>6</sup> —	GPIO[8] E0UC[8] E0UC[14] — EIRQ[3] ABS[0] LIN3RX	SIUL eMIOS_0 eMIOS_0 — SIUL BAM LINFlex_3	I/O I/O I/O — I I I	S	Input, weak pull-up	72	105	129
PA[9]	PCR[9]	AF0 AF1 AF2 AF3 N/A <sup>6</sup>	GPIO[9] E0UC[9] — CS2_1 FAB	SIUL eMIOS_0 — DSPI_1 BAM	I/O I/O — O I	S	Pull- down	73	106	130
PA[10]	PCR[10]	AF0 AF1 AF2 AF3 —	GPIO[10] E0UC[10] SDA LIN2TX ADC1_S[2]	SIUL eMIOS_0 I <sup>2</sup> C_0 LINFlex_2 ADC_1	I/O I/O I/O O I	J	Tristate	74	107	131
PA[11]	PCR[11]	AF0 AF1 AF2 AF3 — — —	GPIO[11] E0UC[11] SCL — EIRQ[16] LIN2RX ADC1_S[3]	SIUL eMIOS_0 I <sup>2</sup> C_0 — SIUL LINFlex_2 ADC_1	I/O I/O I/O — I I I	J	Tristate	75	108	132
PA[12]	PCR[12]	AF0 AF1 AF2 AF3 — —	GPIO[12] — E0UC[28] CS3_1 EIRQ[17] SIN_0	SIUL — eMIOS_0 DSPI_1 SIUL DSPI_0	I/O — I/O O I I	S	Tristate	31	45	53
PA[13]	PCR[13]	AF0 AF1 AF2 AF3	GPIO[13] SOUT_0 E0UC[29] —	SIUL DSPI_0 eMIOS_0 —	I/O O I/O —	M	Tristate	30	44	52
PA[14]	PCR[14]	AF0 AF1 AF2 AF3 —	GPIO[14] SCK_0 CS0_0 E0UC[0] EIRQ[4]	SIUL DSPI_0 DSPI_0 eMIOS_0 SIUL	I/O I/O I/O I/O I	M	Tristate	28	42	50

**Table 2. Functional port pins (continued)**

Port pin	PCR register	Alternate function <sup>1</sup>	Function	Peripheral	I/O direction	Pad type <sup>2</sup>	RESET config. <sup>3</sup>	Pin number		
								100 LQFP	144 LQFP	176 LQFP
PA[15]	PCR[15]	AF0	GPIO[15]	SIUL	I/O	M	Tristate	27	40	48
		AF1	CS0_0	DSPI_0	I/O					
		AF2	SCK_0	DSPI_0	I/O					
		AF3	E0UC[1]	eMIOS_0	I/O					
		—	WKUP[10] <sup>4</sup>	WKUP	I					
<b>Port B</b>										
PB[0]	PCR[16]	AF0	GPIO[16]	SIUL	I/O	M	Tristate	23	31	39
		AF1	CAN0TX	FlexCAN_0	O					
		AF2	E0UC[30]	eMIOS_0	I/O					
		AF3	LIN0TX	LINFlex_0	O					
PB[1]	PCR[17]	AF0	GPIO[17]	SIUL	I/O	S	Tristate	24	32	40
		AF1	—	—	—					
		AF2	E0UC[31]	eMIOS_0	I/O					
		AF3	—	—	—					
		—	WKUP[4] <sup>4</sup>	WKUP	I					
		—	CAN0RX	FlexCAN_0	I					
—	LIN0RX	LINFlex_0	I							
PB[2]	PCR[18]	AF0	GPIO[18]	SIUL	I/O	M	Tristate	100	144	176
		AF1	LIN0TX	LINFlex_0	O					
		AF2	SDA	I <sup>2</sup> C_0	I/O					
		AF3	E0UC[30]	eMIOS_0	I/O					
PB[3]	PCR[19]	AF0	GPIO[19]	SIUL	I/O	S	Tristate	1	1	1
		AF1	E0UC[31]	eMIOS_0	I/O					
		AF2	SCL	I <sup>2</sup> C_0	I/O					
		AF3	—	—	—					
		—	WKUP[11] <sup>4</sup>	WKUP	I					
		—	LIN0RX	LINFlex_0	I					
PB[4]	PCR[20]	AF0	—	—	—	I	Tristate	50	72	88
		AF1	—	—	—					
		AF2	—	—	—					
		AF3	—	—	—					
		—	ADC0_P[0]	ADC_0	I					
		—	ADC1_P[0]	ADC_1	I					
		—	GPIO[20]	SIUL	I					
PB[5]	PCR[21]	AF0	—	—	—	I	Tristate	53	75	91
		AF1	—	—	—					
		AF2	—	—	—					
		AF3	—	—	—					
		—	ADC0_P[1]	ADC_0	I					
		—	ADC1_P[1]	ADC_1	I					
		—	GPIO[21]	SIUL	I					

**Table 2. Functional port pins (continued)**

Port pin	PCR register	Alternate function <sup>1</sup>	Function	Peripheral	I/O direction	Pad type <sup>2</sup>	RESET config. <sup>3</sup>	Pin number		
								100 LQFP	144 LQFP	176 LQFP
PB[6]	PCR[22]	AF0	—	—	—	I	Tristate	54	76	92
		AF1	—	—	—					
		AF2	—	—	—					
		AF3	—	—	—					
		—	ADC0_P[2]	ADC_0	I					
		—	ADC1_P[2]	ADC_1	I					
		—	GPIO[22]	SIUL	I					
PB[7]	PCR[23]	AF0	—	—	—	I	Tristate	55	77	93
		AF1	—	—	—					
		AF2	—	—	—					
		AF3	—	—	—					
		—	ADC0_P[3]	ADC_0	I					
		—	ADC1_P[3]	ADC_1	I					
		—	GPIO[23]	SIUL	I					
PB[8]	PCR[24]	AF0	GPIO[24]	SIUL	I	I	—	39	53	61
		AF1	—	—	—					
		AF2	—	—	—					
		AF3	—	—	—					
		—	OSC32K_XTAL <sup>7</sup>	OSC32K	—					
		—	WKUP[25]	WKUP	I					
		—	ADC0_S[0]	ADC_0	I					
—	ADC1_S[4]	ADC_1	I							
PB[9]	PCR[25]	AF0	GPIO[25]	SIUL	I	I	—	38	52	60
		AF1	—	—	—					
		AF2	—	—	—					
		AF3	—	—	—					
		—	OSC32K_EXTAL <sup>7</sup>	OSC32K	—					
		—	WKUP[26]	WKUP	I					
		—	ADC0_S[1]	ADC_0	I					
—	ADC1_S[5]	ADC_1	I							
PB[10]	PCR[26]	AF0	GPIO[26]	SIUL	I/O	J	Tristate	40	54	62
		AF1	—	—	—					
		AF2	—	—	—					
		AF3	—	—	—					
		—	WKUP[8] <sup>4</sup>	WKUP	I					
		—	ADC0_S[2]	ADC_0	I					
		—	ADC1_S[6]	ADC_1	I					
PB[11]	PCR[27]	AF0	GPIO[27]	SIUL	I/O	J	Tristate	—	—	97
		AF1	E0UC[3]	eMIOS_0	I/O					
		AF2	—	—	—					
		AF3	CS0_0	DSPI_0	I/O					
		—	ADC0_S[3]	ADC_0	I					
PB[12]	PCR[28]	AF0	GPIO[28]	SIUL	I/O	J	Tristate	61	83	101
		AF1	E0UC[4]	eMIOS_0	I/O					
		AF2	—	—	—					
		AF3	CS1_0	DSPI_0	O					
		—	ADC0_X[0]	ADC_0	I					

**Table 2. Functional port pins (continued)**

Port pin	PCR register	Alternate function <sup>1</sup>	Function	Peripheral	I/O direction	Pad type <sup>2</sup>	RESET config. <sup>3</sup>	Pin number		
								100 LQFP	144 LQFP	176 LQFP
PB[13]	PCR[29]	AF0 AF1 AF2 AF3 —	GPIO[29] E0UC[5] — CS2_0 ADC0_X[1]	SIUL eMIOS_0 — DSPI_0 ADC_0	I/O I/O — O I	J	Tristate	63	85	103
PB[14]	PCR[30]	AF0 AF1 AF2 AF3 —	GPIO[30] E0UC[6] — CS3_0 ADC0_X[2]	SIUL eMIOS_0 — DSPI_0 ADC_0	I/O I/O — O I	J	Tristate	65	87	105
PB[15]	PCR[31]	AF0 AF1 AF2 AF3 —	GPIO[31] E0UC[7] — CS4_0 ADC0_X[3]	SIUL eMIOS_0 — DSPI_0 ADC_0	I/O I/O — O I	J	Tristate	67	89	107
<b>Port C</b>										
PC[0] <sup>8</sup>	PCR[32]	AF0 AF1 AF2 AF3	GPIO[32] — TDI —	SIUL — JTAGC —	I/O — I —	M	Input, weak pull-up	87	126	154
PC[1] <sup>8</sup>	PCR[33]	AF0 AF1 AF2 AF3	GPIO[33] — TDO —	SIUL — JTAGC —	I/O — O —	F <sup>9</sup>	Tristate	82	121	149
PC[2]	PCR[34]	AF0 AF1 AF2 AF3 —	GPIO[34] SCK_1 CAN4TX DEBUG[0] EIRQ[5]	SIUL DSPI_1 FlexCAN_4 SSCM SIUL	I/O I/O O O I	M	Tristate	78	117	145
PC[3]	PCR[35]	AF0 AF1 AF2 AF3 — — —	GPIO[35] CS0_1 MA[0] DEBUG[1] EIRQ[6] CAN1RX CAN4RX	SIUL DSPI_1 ADC_0 SSCM SIUL FlexCAN_1 FlexCAN_4	I/O I/O O O I I I	S	Tristate	77	116	144
PC[4]	PCR[36]	AF0 AF1 AF2 AF3 — — —	GPIO[36] E1UC[31] — DEBUG[2] EIRQ[18] SIN_1 CAN3RX	SIUL eMIOS_1 — SSCM SIUL DSPI_1 FlexCAN_3	I/O I/O — O I I I	M	Tristate	92	131	159

**Table 2. Functional port pins (continued)**

Port pin	PCR register	Alternate function <sup>1</sup>	Function	Peripheral	I/O direction	Pad type <sup>2</sup>	RESET config. <sup>3</sup>	Pin number		
								100 LQFP	144 LQFP	176 LQFP
PC[5]	PCR[37]	AF0 AF1 AF2 AF3 —	GPIO[37] SOUT_1 CAN3TX DEBUG[3] EIRQ[7]	SIUL DSPI_1 FlexCAN_3 SSCM SIUL	I/O O O O I	M	Tristate	91	130	158
PC[6]	PCR[38]	AF0 AF1 AF2 AF3	GPIO[38] LIN1TX E1UC[28] DEBUG[4]	SIUL LINFlex_1 eMIOS_1 SSCM	I/O O I/O O	S	Tristate	25	36	44
PC[7]	PCR[39]	AF0 AF1 AF2 AF3 — —	GPIO[39] — E1UC[29] DEBUG[5] LIN1RX WKUP[12] <sup>4</sup>	SIUL — eMIOS_1 SSCM LINFlex_1 WKUP	I/O — I/O O I I	S	Tristate	26	37	45
PC[8]	PCR[40]	AF0 AF1 AF2 AF3	GPIO[40] LIN2TX E0UC[3] DEBUG[6]	SIUL LINFlex_2 eMIOS_0 SSCM	I/O O I/O O	S	Tristate	99	143	175
PC[9]	PCR[41]	AF0 AF1 AF2 AF3 — —	GPIO[41] — E0UC[7] DEBUG[7] WKUP[13] <sup>4</sup> LIN2RX	SIUL — eMIOS_0 SSCM WKUP LINFlex_2	I/O — I/O O I I	S	Tristate	2	2	2
PC[10]	PCR[42]	AF0 AF1 AF2 AF3	GPIO[42] CAN1TX CAN4TX MA[1]	SIUL FlexCAN_1 FlexCAN_4 ADC_0	I/O O O O	M	Tristate	22	28	36
PC[11]	PCR[43]	AF0 AF1 AF2 AF3 — — —	GPIO[43] — — MA[2] WKUP[5] <sup>4</sup> CAN1RX CAN4RX	SIUL — — ADC_0 WKUP FlexCAN_1 FlexCAN_4	I/O — — O I I I	S	Tristate	21	27	35
PC[12]	PCR[44]	AF0 AF1 AF2 AF3 — —	GPIO[44] E0UC[12] — — EIRQ[19] SIN_2	SIUL eMIOS_0 — — SIUL DSPI_2	I/O I/O — — I I	M	Tristate	97	141	173
PC[13]	PCR[45]	AF0 AF1 AF2 AF3	GPIO[45] E0UC[13] SOUT_2 —	SIUL eMIOS_0 DSPI_2 —	I/O I/O O —	S	Tristate	98	142	174

**Table 2. Functional port pins (continued)**

Port pin	PCR register	Alternate function <sup>1</sup>	Function	Peripheral	I/O direction	Pad type <sup>2</sup>	RESET config. <sup>3</sup>	Pin number		
								100 LQFP	144 LQFP	176 LQFP
PC[14]	PCR[46]	AF0	GPIO[46]	SIUL	I/O	S	Tristate	3	3	3
		AF1	E0UC[14]	eMIOS_0	I/O					
		AF2	SCK_2	DSPI_2	I/O					
		AF3	—	—	—					
		—	EIRQ[8]	SIUL	I					
PC[15]	PCR[47]	AF0	GPIO[47]	SIUL	I/O	M	Tristate	4	4	4
		AF1	E0UC[15]	eMIOS_0	I/O					
		AF2	CS0_2	DSPI_2	I/O					
		AF3	—	—	—					
		—	EIRQ[20]	SIUL	I					
<b>Port D</b>										
PD[0]	PCR[48]	AF0	GPIO[48]	SIUL	I	I	Tristate	41	63	77
		AF1	—	—	—					
		AF2	—	—	—					
		AF3	—	—	—					
		—	WKUP[27]	WKUP	I					
		—	ADC0_P[4]	ADC_0	I					
		—	ADC1_P[4]	ADC_1	I					
PD[1]	PCR[49]	AF0	GPIO[49]	SIUL	I	I	Tristate	42	64	78
		AF1	—	—	—					
		AF2	—	—	—					
		AF3	—	—	—					
		—	WKUP[28]	WKUP	I					
		—	ADC0_P[5]	ADC_0	I					
		—	ADC1_P[5]	ADC_1	I					
PD[2]	PCR[50]	AF0	GPIO[50]	SIUL	I	I	Tristate	43	65	79
		AF1	—	—	—					
		AF2	—	—	—					
		AF3	—	—	—					
		—	ADC0_P[6]	ADC_0	I					
		—	ADC1_P[6]	ADC_1	I					
PD[3]	PCR[51]	AF0	GPIO[51]	SIUL	I	I	Tristate	44	66	80
		AF1	—	—	—					
		AF2	—	—	—					
		AF3	—	—	—					
		—	ADC0_P[7]	ADC_0	I					
		—	ADC1_P[7]	ADC_1	I					
PD[4]	PCR[52]	AF0	GPIO[52]	SIUL	I	I	Tristate	45	67	81
		AF1	—	—	—					
		AF2	—	—	—					
		AF3	—	—	—					
		—	ADC0_P[8]	ADC_0	I					
		—	ADC1_P[8]	ADC_1	I					

**Table 2. Functional port pins (continued)**

Port pin	PCR register	Alternate function <sup>1</sup>	Function	Peripheral	I/O direction	Pad type <sup>2</sup>	RESET config. <sup>3</sup>	Pin number		
								100 LQFP	144 LQFP	176 LQFP
PD[5]	PCR[53]	AF0	GPIO[53]	SIUL	I	I	Tristate	46	68	82
		AF1	—	—	—					
		AF2	—	—	—					
		AF3	—	—	—					
		—	ADC0_P[9]	ADC_0	I					
		—	ADC1_P[9]	ADC_1	I					
PD[6]	PCR[54]	AF0	GPIO[54]	SIUL	I	I	Tristate	47	69	83
		AF1	—	—	—					
		AF2	—	—	—					
		AF3	—	—	—					
		—	ADC0_P[10]	ADC_0	I					
		—	ADC1_P[10]	ADC_1	I					
PD[7]	PCR[55]	AF0	GPIO[55]	SIUL	I	I	Tristate	48	70	84
		AF1	—	—	—					
		AF2	—	—	—					
		AF3	—	—	—					
		—	ADC0_P[11]	ADC_0	I					
		—	ADC1_P[11]	ADC_1	I					
PD[8]	PCR[56]	AF0	GPIO[56]	SIUL	I	I	Tristate	49	71	87
		AF1	—	—	—					
		AF2	—	—	—					
		AF3	—	—	—					
		—	ADC0_P[12]	ADC_0	I					
		—	ADC1_P[12]	ADC_1	I					
PD[9]	PCR[57]	AF0	GPIO[57]	SIUL	I	I	Tristate	56	78	94
		AF1	—	—	—					
		AF2	—	—	—					
		AF3	—	—	—					
		—	ADC0_P[13]	ADC_0	I					
		—	ADC1_P[13]	ADC_1	I					
PD[10]	PCR[58]	AF0	GPIO[58]	SIUL	I	I	Tristate	57	79	95
		AF1	—	—	—					
		AF2	—	—	—					
		AF3	—	—	—					
		—	ADC0_P[14]	ADC_0	I					
		—	ADC1_P[14]	ADC_1	I					
PD[11]	PCR[59]	AF0	GPIO[59]	SIUL	I	I	Tristate	58	80	96
		AF1	—	—	—					
		AF2	—	—	—					
		AF3	—	—	—					
		—	ADC0_P[15]	ADC_0	I					
		—	ADC1_P[15]	ADC_1	I					
PD[12]	PCR[60]	AF0	GPIO[60]	SIUL	I/O	J	Tristate	—	—	100
		AF1	CS5_0	DSPI_0	O					
		AF2	E0UC[24]	eMIOS_0	I/O					
		AF3	—	—	—					
		—	ADC0_S[4]	ADC_0	I					

**Table 2. Functional port pins (continued)**

Port pin	PCR register	Alternate function <sup>1</sup>	Function	Peripheral	I/O direction	Pad type <sup>2</sup>	RESET config. <sup>3</sup>	Pin number		
								100 LQFP	144 LQFP	176 LQFP
PD[13]	PCR[61]	AF0	GPIO[61]	SIUL	I/O	J	Tristate	62	84	102
		AF1	CS0_1	DSPI_1	I/O					
		AF2	E0UC[25]	eMIOS_0	I/O					
		AF3	—	—	—					
		—	ADC0_S[5]	ADC_0	I					
PD[14]	PCR[62]	AF0	GPIO[62]	SIUL	I/O	J	Tristate	64	86	104
		AF1	CS1_1	DSPI_1	O					
		AF2	E0UC[26]	eMIOS_0	I/O					
		AF3	—	—	—					
		—	ADC0_S[6]	ADC_0	I					
PD[15]	PCR[63]	AF0	GPIO[63]	SIUL	I/O	J	Tristate	66	88	106
		AF1	CS2_1	DSPI_1	O					
		AF2	E0UC[27]	eMIOS_0	I/O					
		AF3	—	—	—					
		—	ADC0_S[7]	ADC_0	I					
<b>Port E</b>										
PE[0]	PCR[64]	AF0	GPIO[64]	SIUL	I/O	S	Tristate	6	10	18
		AF1	E0UC[16]	eMIOS_0	I/O					
		AF2	—	—	—					
		AF3	—	—	—					
		—	WKUP[6] <sup>4</sup>	WKUP	I					
—	CAN5RX	FlexCAN_5	I							
PE[1]	PCR[65]	AF0	GPIO[65]	SIUL	I/O	M	Tristate	8	12	20
		AF1	E0UC[17]	eMIOS_0	I/O					
		AF2	CAN5TX	FlexCAN_5	O					
		AF3	—	—	—					
PE[2]	PCR[66]	AF0	GPIO[66]	SIUL	I/O	M	Tristate	89	128	156
		AF1	E0UC[18]	eMIOS_0	I/O					
		AF2	—	—	—					
		AF3	—	—	—					
		—	EIRQ[21]	SIUL	I					
—	SIN_1	DSPI_1	I							
PE[3]	PCR[67]	AF0	GPIO[67]	SIUL	I/O	M	Tristate	90	129	157
		AF1	E0UC[19]	eMIOS_0	I/O					
		AF2	SOUT_1	DSPI_1	O					
		AF3	—	—	—					
PE[4]	PCR[68]	AF0	GPIO[68]	SIUL	I/O	M	Tristate	93	132	160
		AF1	E0UC[20]	eMIOS_0	I/O					
		AF2	SCK_1	DSPI_1	I/O					
		AF3	—	—	—					
		—	EIRQ[9]	SIUL	I					
PE[5]	PCR[69]	AF0	GPIO[69]	SIUL	I/O	M	Tristate	94	133	161
		AF1	E0UC[21]	eMIOS_0	I/O					
		AF2	CS0_1	DSPI_1	I/O					
		AF3	MA[2]	ADC_0	O					
		—	—	—	—					

**Table 2. Functional port pins (continued)**

Port pin	PCR register	Alternate function <sup>1</sup>	Function	Peripheral	I/O direction	Pad type <sup>2</sup>	RESET config. <sup>3</sup>	Pin number		
								100 LQFP	144 LQFP	176 LQFP
PE[6]	PCR[70]	AF0	GPIO[70]	SIUL	I/O	M	Tristate	95	139	167
		AF1	E0UC[22]	eMIOS_0	I/O					
		AF2	CS3_0	DSPI_0	O					
		AF3	MA[1]	ADC_0	O					
		—	EIRQ[22]	SIUL	I					
PE[7]	PCR[71]	AF0	GPIO[71]	SIUL	I/O	M	Tristate	96	140	168
		AF1	E0UC[23]	eMIOS_0	I/O					
		AF2	CS2_0	DSPI_0	O					
		AF3	MA[0]	ADC_0	O					
		—	EIRQ[23]	SIUL	I					
PE[8]	PCR[72]	AF0	GPIO[72]	SIUL	I/O	M	Tristate	9	13	21
		AF1	CAN2TX	FlexCAN_2	O					
		AF2	E0UC[22]	eMIOS_0	I/O					
		AF3	CAN3TX	FlexCAN_3	O					
PE[9]	PCR[73]	AF0	GPIO[73]	SIUL	I/O	S	Tristate	10	14	22
		AF1	—	—	—					
		AF2	E0UC[23]	eMIOS_0	I/O					
		AF3	—	—	—					
		—	WKUP[7] <sup>4</sup>	WKUP	I					
		—	CAN2RX	FlexCAN_2	I					
—	CAN3RX	FlexCAN_3	I							
PE[10]	PCR[74]	AF0	GPIO[74]	SIUL	I/O	S	Tristate	11	15	23
		AF1	LIN3TX	LINFlex_3	O					
		AF2	CS3_1	DSPI_1	O					
		AF3	E1UC[30]	eMIOS_1	I/O					
		—	EIRQ[10]	SIUL	I					
PE[11]	PCR[75]	AF0	GPIO[75]	SIUL	I/O	S	Tristate	13	17	25
		AF1	E0UC[24]	eMIOS_0	I/O					
		AF2	CS4_1	DSPI_1	O					
		AF3	—	—	—					
		—	LIN3RX	LINFlex_3	I					
—	WKUP[14] <sup>4</sup>	WKUP	I							
PE[12]	PCR[76]	AF0	GPIO[76]	SIUL	I/O	J	Tristate	76	109	133
		AF1	—	—	—					
		AF2	E1UC[19] <sup>10</sup>	eMIOS_1	I/O					
		AF3	—	—	—					
		—	EIRQ[11]	SIUL	I					
		—	SIN_2	DSPI_2	I					
—	ADC1_S[7]	ADC_1	I							
PE[13]	PCR[77]	AF0	GPIO[77]	SIUL	I/O	S	Tristate	—	103	127
		AF1	SOUT_2	DSPI_2	O					
		AF2	E1UC[20]	eMIOS_1	I/O					
		AF3	—	—	—					

**Table 2. Functional port pins (continued)**

Port pin	PCR register	Alternate function <sup>1</sup>	Function	Peripheral	I/O direction	Pad type <sup>2</sup>	RESET config. <sup>3</sup>	Pin number		
								100 LQFP	144 LQFP	176 LQFP
PE[14]	PCR[78]	AF0	GPIO[78]	SIUL	I/O	S	Tristate	—	112	136
		AF1	SCK_2	DSPI_2	I/O					
		AF2	E1UC[21]	eMIOS_1	I/O					
		AF3	—	—	—					
		—	EIRQ[12]	SIUL	I					
PE[15]	PCR[79]	AF0	GPIO[79]	SIUL	I/O	M	Tristate	—	113	137
		AF1	CS0_2	DSPI_2	I/O					
		AF2	E1UC[22]	eMIOS_1	I/O					
		AF3	—	—	—					
<b>Port F</b>										
PF[0]	PCR[80]	AF0	GPIO[80]	SIUL	I/O	J	Tristate	—	55	63
		AF1	E0UC[10]	eMIOS_0	I/O					
		AF2	CS3_1	DSPI_1	O					
		AF3	—	—	—					
		—	ADC0_S[8]	ADC_0	I					
PF[1]	PCR[81]	AF0	GPIO[81]	SIUL	I/O	J	Tristate	—	56	64
		AF1	E0UC[11]	eMIOS_0	I/O					
		AF2	CS4_1	DSPI_1	O					
		AF3	—	—	—					
		—	ADC0_S[9]	ADC_0	I					
PF[2]	PCR[82]	AF0	GPIO[82]	SIUL	I/O	J	Tristate	—	57	65
		AF1	E0UC[12]	eMIOS_0	I/O					
		AF2	CS0_2	DSPI_2	O					
		AF3	—	—	—					
		—	ADC0_S[10]	ADC_0	I					
PF[3]	PCR[83]	AF0	GPIO[83]	SIUL	I/O	J	Tristate	—	58	66
		AF1	E0UC[13]	eMIOS_0	I/O					
		AF2	CS1_2	DSPI_2	O					
		AF3	—	—	—					
		—	ADC0_S[11]	ADC_0	I					
PF[4]	PCR[84]	AF0	GPIO[84]	SIUL	I/O	J	Tristate	—	59	67
		AF1	E0UC[14]	eMIOS_0	I/O					
		AF2	CS2_2	DSPI_2	O					
		AF3	—	—	—					
		—	ADC0_S[12]	ADC_0	I					
PF[5]	PCR[85]	AF0	GPIO[85]	SIUL	I/O	J	Tristate	—	60	68
		AF1	E0UC[22]	eMIOS_0	I/O					
		AF2	CS3_2	DSPI_2	O					
		AF3	—	—	—					
		—	ADC0_S[13]	ADC_0	I					
PF[6]	PCR[86]	AF0	GPIO[86]	SIUL	I/O	J	Tristate	—	61	69
		AF1	E0UC[23]	eMIOS_0	I/O					
		AF2	CS1_1	DSPI_1	O					
		AF3	—	—	—					
		—	ADC0_S[14]	ADC_0	I					

**Table 2. Functional port pins (continued)**

Port pin	PCR register	Alternate function <sup>1</sup>	Function	Peripheral	I/O direction	Pad type <sup>2</sup>	RESET config. <sup>3</sup>	Pin number		
								100 LQFP	144 LQFP	176 LQFP
PF[7]	PCR[87]	AF0	GPIO[87]	SIUL	I/O	J	Tristate	—	62	70
		AF1	—	—	—					
		AF2	CS2_1	DSPI_1	O					
		AF3	—	—	—					
		—	ADC0_S[15]	ADC_0	I					
PF[8]	PCR[88]	AF0	GPIO[88]	SIUL	I/O	M	Tristate	—	34	42
		AF1	CAN3TX	FlexCAN_3	O					
		AF2	CS4_0	DSPI_0	O					
		AF3	CAN2TX	FlexCAN_2	O					
PF[9]	PCR[89]	AF0	GPIO[89]	SIUL	I/O	S	Tristate	—	33	41
		AF1	E1UC[1]	eMIOS_1	I/O					
		AF2	CS5_0	DSPI_0	O					
		AF3	—	—	—					
		—	WKUP[22] <sup>4</sup>	WKUP	I					
		—	CAN2RX	FlexCAN_2	I					
—	CAN3RX	FlexCAN_3	I							
PF[10]	PCR[90]	AF0	GPIO[90]	SIUL	I/O	M	Tristate	—	38	46
		AF1	CS1_0	DSPI_0	O					
		AF2	LIN4TX	LINFlex_4	O					
		AF3	E1UC[2]	eMIOS_1	I/O					
PF[11]	PCR[91]	AF0	GPIO[91]	SIUL	I/O	S	Tristate	—	39	47
		AF1	CS2_0	DSPI_0	O					
		AF2	E1UC[3]	eMIOS_1	I/O					
		AF3	—	—	—					
		—	WKUP[15] <sup>4</sup>	WKUP	I					
		—	LIN4RX	LINFlex_4	I					
PF[12]	PCR[92]	AF0	GPIO[92]	SIUL	I/O	M	Tristate	—	35	43
		AF1	E1UC[25]	eMIOS_1	I/O					
		AF2	LIN5TX	LINFlex_5	O					
		AF3	—	—	—					
PF[13]	PCR[93]	AF0	GPIO[93]	SIUL	I/O	S	Tristate	—	41	49
		AF1	E1UC[26]	eMIOS_1	I/O					
		AF2	—	—	—					
		AF3	—	—	—					
		—	WKUP[16] <sup>4</sup>	WKUP	I					
		—	LIN5RX	LINFlex_5	I					
PF[14]	PCR[94]	AF0	GPIO[94]	SIUL	I/O	M	Tristate	—	102	126
		AF1	CAN4TX	FlexCAN_4	O					
		AF2	E1UC[27]	eMIOS_1	I/O					
		AF3	CAN1TX	FlexCAN_1	O					

**Table 2. Functional port pins (continued)**

Port pin	PCR register	Alternate function <sup>1</sup>	Function	Peripheral	I/O direction	Pad type <sup>2</sup>	RESET config. <sup>3</sup>	Pin number		
								100 LQFP	144 LQFP	176 LQFP
PF[15]	PCR[95]	AF0	GPIO[95]	SIUL	I/O	S	Tristate	—	101	125
		AF1	E1UC[4]	eMIOS_1	I/O					
		AF2	—	—	—					
		AF3	—	—	—					
		—	EIRQ[13]	SIUL	I					
		—	CAN1RX	FlexCAN_1	I					
—	CAN4RX	FlexCAN_4	I							
<b>Port G</b>										
PG[0]	PCR[96]	AF0	GPIO[96]	SIUL	I/O	M	Tristate	—	98	122
		AF1	CAN5TX	FlexCAN_5	O					
		AF2	E1UC[23]	eMIOS_1	I/O					
		AF3	—	—	—					
PG[1]	PCR[97]	AF0	GPIO[97]	SIUL	I/O	S	Tristate	—	97	121
		AF1	—	—	—					
		AF2	E1UC[24]	eMIOS_1	I/O					
		AF3	—	—	—					
		—	EIRQ[14]	SIUL	I					
—	CAN5RX	FlexCAN_5	I							
PG[2]	PCR[98]	AF0	GPIO[98]	SIUL	I/O	M	Tristate	—	8	16
		AF1	E1UC[11]	eMIOS_1	I/O					
		AF2	SOUT_3	DSPI_3	O					
		AF3	—	—	—					
PG[3]	PCR[99]	AF0	GPIO[99]	SIUL	I/O	S	Tristate	—	7	15
		AF1	E1UC[12]	eMIOS_1	I/O					
		AF2	CS0_3	DSPI_3	O					
		AF3	—	—	—					
		—	WKUP[17] <sup>4</sup>	WKUP	I					
PG[4]	PCR[100]	AF0	GPIO[100]	SIUL	I/O	M	Tristate	—	6	14
		AF1	E1UC[13]	eMIOS_1	I/O					
		AF2	SCK_3	DSPI_3	I/O					
		AF3	—	—	—					
PG[5]	PCR[101]	AF0	GPIO[101]	SIUL	I/O	S	Tristate	—	5	13
		AF1	E1UC[14]	eMIOS_1	I/O					
		AF2	—	—	—					
		AF3	—	—	—					
		—	WKUP[18] <sup>4</sup>	WKUP	I					
—	SIN_3	DSPI_3	I							
PG[6]	PCR[102]	AF0	GPIO[102]	SIUL	I/O	M	Tristate	—	30	38
		AF1	E1UC[15]	eMIOS_1	I/O					
		AF2	LIN6TX	LINFlex_6	O					
		AF3	—	—	—					

**Table 2. Functional port pins (continued)**

Port pin	PCR register	Alternate function <sup>1</sup>	Function	Peripheral	I/O direction	Pad type <sup>2</sup>	RESET config. <sup>3</sup>	Pin number		
								100 LQFP	144 LQFP	176 LQFP
PG[7]	PCR[103]	AF0 AF1 AF2 AF3 — —	GPIO[103] E1UC[16] E1UC[30] — WKUP[20] <sup>4</sup> LIN6RX	SIUL eMIOS_1 eMIOS_1 — WKUP LINFlex_6	I/O I/O I/O — I I	S	Tristate	—	29	37
PG[8]	PCR[104]	AF0 AF1 AF2 AF3 —	GPIO[104] E1UC[17] LIN7TX CS0_2 EIRQ[15]	SIUL eMIOS_1 LINFlex_7 DSPI_2 SIUL	I/O I/O O I/O I	S	Tristate	—	26	34
PG[9]	PCR[105]	AF0 AF1 AF2 AF3 — —	GPIO[105] E1UC[18] — SCK_2 WKUP[21] <sup>4</sup> LIN7RX	SIUL eMIOS_1 — DSPI_2 WKUP LINFlex_7	I/O I/O — I/O I I	S	Tristate	—	25	33
PG[10]	PCR[106]	AF0 AF1 AF2 AF3 —	GPIO[106] E0UC[24] E1UC[31] — SIN_4	SIUL eMIOS_0 eMIOS_1 — DSPI_4	I/O I/O I/O — I	S	Tristate	—	114	138
PG[11]	PCR[107]	AF0 AF1 AF2 AF3	GPIO[107] E0UC[25] CS0_4 —	SIUL eMIOS_0 DSPI_4 —	I/O I/O O —	M	Tristate	—	115	139
PG[12]	PCR[108]	AF0 AF1 AF2 AF3	GPIO[108] E0UC[26] SOUT_4 —	SIUL eMIOS_0 DSPI_4 —	I/O I/O O —	M	Tristate	—	92	116
PG[13]	PCR[109]	AF0 AF1 AF2 AF3	GPIO[109] E0UC[27] SCK_4 —	SIUL eMIOS_0 DSPI_4 —	I/O I/O I/O —	M	Tristate	—	91	115
PG[14]	PCR[110]	AF0 AF1 AF2 AF3	GPIO[110] E1UC[0] — —	SIUL eMIOS_1 — —	I/O I/O — —	S	Tristate	—	110	134
PG[15]	PCR[111]	AF0 AF1 AF2 AF3 —	GPIO[111] E1UC[1] — — —	SIUL eMIOS_1 — — —	I/O I/O — — —	M	Tristate	—	111	135
<b>Port H</b>										

**Table 2. Functional port pins (continued)**

Port pin	PCR register	Alternate function <sup>1</sup>	Function	Peripheral	I/O direction	Pad type <sup>2</sup>	RESET config. <sup>3</sup>	Pin number		
								100 LQFP	144 LQFP	176 LQFP
PH[0]	PCR[112]	AF0 AF1 AF2 AF3 —	GPIO[112] E1UC[2] — — SIN_1	SIUL eMIOS_1 — — DSPI_1	I/O I/O — — I	M	Tristate	—	93	117
PH[1]	PCR[113]	AF0 AF1 AF2 AF3	GPIO[113] E1UC[3] SOUT_1 —	SIUL eMIOS_1 DSPI_1 —	I/O I/O O —	M	Tristate	—	94	118
PH[2]	PCR[114]	AF0 AF1 AF2 AF3	GPIO[114] E1UC[4] SCK_1 —	SIUL eMIOS_1 DSPI_1 —	I/O I/O I/O —	M	Tristate	—	95	119
PH[3]	PCR[115]	AF0 AF1 AF2 AF3	GPIO[115] E1UC[5] CS0_1 —	SIUL eMIOS_1 DSPI_1 —	I/O I/O I/O —	M	Tristate	—	96	120
PH[4]	PCR[116]	AF0 AF1 AF2 AF3	GPIO[116] E1UC[6] — —	SIUL eMIOS_1 — —	I/O I/O — —	M	Tristate	—	134	162
PH[5]	PCR[117]	AF0 AF1 AF2 AF3	GPIO[117] E1UC[7] — —	SIUL eMIOS_1 — —	I/O I/O — —	S	Tristate	—	135	163
PH[6]	PCR[118]	AF0 AF1 AF2 AF3	GPIO[118] E1UC[8] — MA[2]	SIUL eMIOS_1 — ADC_0	I/O I/O — O	M	Tristate	—	136	164
PH[7]	PCR[119]	AF0 AF1 AF2 AF3	GPIO[119] E1UC[9] CS3_2 MA[1]	SIUL eMIOS_1 DSPI_2 ADC_0	I/O I/O O O	M	Tristate	—	137	165
PH[8]	PCR[120]	AF0 AF1 AF2 AF3	GPIO[120] E1UC[10] CS2_2 MA[0]	SIUL eMIOS_1 DSPI_2 ADC_0	I/O I/O O O	M	Tristate	—	138	166
PH[9] <sup>8</sup>	PCR[121]	AF0 AF1 AF2 AF3	GPIO[121] — TCK —	SIUL — JTAGC —	I/O — I —	S	Input, weak pull-up	88	127	155
PH[10] <sup>8</sup>	PCR[122]	AF0 AF1 AF2 AF3	GPIO[122] — TMS —	SIUL — JTAGC —	I/O — I —	M	Input, weak pull-up	81	120	148

**Table 2. Functional port pins (continued)**

Port pin	PCR register	Alternate function <sup>1</sup>	Function	Peripheral	I/O direction	Pad type <sup>2</sup>	RESET config. <sup>3</sup>	Pin number		
								100 LQFP	144 LQFP	176 LQFP
PH[11]	PCR[123]	AF0 AF1 AF2 AF3	GPIO[123] SOUT_3 CS0_4 E1UC[5]	SIUL DSPI_3 DSPI_4 eMIOS_1	I/O O I/O I/O	M	Tristate	—	—	140
PH[12]	PCR[124]	AF0 AF1 AF2 AF3	GPIO[124] SCK_3 CS1_4 E1UC[25]	SIUL DSPI_3 DSPI_4 eMIOS_1	I/O I/O I/O —	M	Tristate	—	—	141
PH[13]	PCR[125]	AF0 AF1 AF2 AF3	GPIO[125] SOUT_4 CS0_3 E1UC[26]	SIUL DSPI_4 DSPI_3 eMIOS_1	I/O O I/O —	M	Tristate	—	—	9
PH[14]	PCR[126]	AF0 AF1 AF2 AF3	GPIO[126] SCK_4 CS1_3 E1UC[27]	SIUL DSPI_4 DSPI_3 eMIOS_1	I/O I/O I/O —	M	Tristate	—	—	10
PH[15]	PCR[127]	AF0 AF1 AF2 AF3	GPIO[127] SOUT_5 — E1UC[17]	SIUL DSPI_5 — eMIOS_1	I/O O — —	M	Tristate	—	—	8
<b>Port I</b>										
PI[0]	PCR[128]	AF0 AF1 AF2 AF3	GPIO[128] E0UC[28] — —	SIUL eMIOS_0 — —	I/O I/O — —	S	Tristate	—	—	172
PI[1]	PCR[129]	AF0 AF1 AF2 AF3 — —	GPIO[129] E0UC[29] — — WKUP[24] <sup>4</sup> —	SIUL eMIOS_0 — — WKUP —	I/O I/O — — I —	S	Tristate	—	—	171
PI[2]	PCR[130]	AF0 AF1 AF2 AF3	GPIO[130] E0UC[30] — —	SIUL eMIOS_0 — —	I/O I/O — —	S	Tristate	—	—	170
PI[3]	PCR[131]	AF0 AF1 AF2 AF3 — —	GPIO[131] E0UC[31] — — WKUP[23] <sup>4</sup> —	SIUL eMIOS_0 — — WKUP —	I/O I/O — — I —	S	Tristate	—	—	169
PI[4]	PCR[132]	AF0 AF1 AF2 AF3	GPIO[132] E1UC[28] SOUT_4 —	SIUL eMIOS_1 DSPI_4 —	I/O I/O O —	S	Tristate	—	—	143

**Table 2. Functional port pins (continued)**

Port pin	PCR register	Alternate function <sup>1</sup>	Function	Peripheral	I/O direction	Pad type <sup>2</sup>	RESET config. <sup>3</sup>	Pin number		
								100 LQFP	144 LQFP	176 LQFP
PI[5]	PCR[133]	AF0 AF1 AF2 AF3	GPIO[133] E1UC[29] SCK_4 —	SIUL eMIOS_1 DSPI_4 —	I/O I/O I/O —	S	Tristate	—	—	142
PI[6]	PCR[134]	AF0 AF1 AF2 AF3	GPIO[134] E1UC[30] CS0_4 —	SIUL eMIOS_1 DSPI_4 —	I/O I/O I/O —	S	Tristate	—	—	11
PI[7]	PCR[135]	AF0 AF1 AF2 AF3	GPIO[135] E1UC[31] CS1_4 —	SIUL eMIOS_1 DSPI_4 —	I/O I/O I/O —	S	Tristate	—	—	12
PI[8]	PCR[136]	AF0 AF1 AF2 AF3 —	GPIO[136] — — — ADC0_S[16]	SIUL — — — ADC_0	I/O — — — I	J	Tristate	—	—	108
PI[9]	PCR[137]	AF0 AF1 AF2 AF3 —	GPIO[137] — — — ADC0_S[17]	SIUL — — — ADC_0	I/O — — — I	J	Tristate	—	—	109
PI[10]	PCR[138]	AF0 AF1 AF2 AF3 —	GPIO[138] — — — ADC0_S[18]	SIUL — — — ADC_0	I/O — — — I	J	Tristate	—	—	110
PI[11]	PCR[139]	AF0 AF1 AF2 AF3 — —	GPIO[139] — — — ADC0_S[19] SIN_3	SIUL — — — ADC_0 DSPI_3	I/O — — — I I	J	Tristate	—	—	111
PI[12]	PCR[140]	AF0 AF1 AF2 AF3 —	GPIO[140] CS0_3 — — ADC0_S[20]	SIUL DSPI_3 — — ADC_0	I/O I/O — — I	J	Tristate	—	—	112
PI[13]	PCR[141]	AF0 AF1 AF2 AF3 —	GPIO[141] CS1_3 — — ADC0_S[21]	SIUL DSPI_3 — — ADC_0	I/O I/O — — I	J	Tristate	—	—	113

**Table 2. Functional port pins (continued)**

Port pin	PCR register	Alternate function <sup>1</sup>	Function	Peripheral	I/O direction	Pad type <sup>2</sup>	RESET config. <sup>3</sup>	Pin number		
								100 LQFP	144 LQFP	176 LQFP
PI[14]	PCR[142]	AF0	GPIO[142]	SIUL	I/O	J	Tristate	—	—	76
		AF1	—	—	—					
		AF2	—	—	—					
		AF3	—	—	—					
		—	ADC0_S[22] SIN_4	ADC_0 DSPI_4	I I					
PI[15]	PCR[143]	AF0	GPIO[143]	SIUL	I/O	J	Tristate	—	—	75
		AF1	CS0_4	DSPI_4	I/O					
		AF2	—	—	—					
		AF3	—	—	—					
		—	ADC0_S[23]	ADC_0	I					
<b>Port J</b>										
PJ[0]	PCR[144]	AF0	GPIO[144]	SIUL	I/O	J	Tristate	—	—	74
		AF1	CS1_4	DSPI_4	I/O					
		AF2	—	—	—					
		AF3	—	—	—					
		—	ADC0_S[24]	ADC_0	I					
PJ[1]	PCR[145]	AF0	GPIO[145]	SIUL	I/O	J	Tristate	—	—	73
		AF1	—	—	—					
		AF2	—	—	—					
		AF3	—	—	—					
		—	ADC0_S[25] SIN_5	ADC_0 DSPI_5	I I					
PJ[2]	PCR[146]	AF0	GPIO[146]	SIUL	I/O	J	Tristate	—	—	72
		AF1	CS0_5	DSPI_5	I/O					
		AF2	—	—	—					
		AF3	—	—	—					
		—	ADC0_S[26]	ADC_0	I					
PJ[3]	PCR[147]	AF0	GPIO[147]	SIUL	I/O	J	Tristate	—	—	71
		AF1	CS1_5	DSPI_5	I/O					
		AF2	—	—	—					
		AF3	—	—	—					
		—	ADC0_S[27]	ADC_0	I					
PJ[4]	PCR[148]	AF0	GPIO[148]	SIUL	I/O	M	Tristate	—	—	5
		AF1	SCK_5	DSPI_5	I/O					
		AF2	E1UC[18]	eMIOS_1	—					
		AF3	—	—	—					
		—	—	—	—					

<sup>1</sup> Alternate functions are chosen by setting the values of the PCR.PA bitfields inside the SIUL module. PCR.PA = 00 → AF0; PCR.PA = 01 → AF1; PCR.PA = 10 → AF2; PCR.PA = 11 → AF3. This is intended to select the output functions; to use one of the input functions, the PCR.IBE bit must be written to '1', regardless of the values selected in the PCR.PA bitfields. For this reason, the value corresponding to an input only function is reported as "—".

<sup>2</sup> See [Table 3](#).

<sup>3</sup> The RESET configuration applies during and after reset.

- <sup>4</sup> All WKUP pins also support external interrupt capability. See the WKPU chapter of the *MPC5606BK Microcontroller Reference Manual* for further details.
- <sup>5</sup> NMI has higher priority than alternate function. When NMI is selected, the PCR.AF field is ignored.
- <sup>6</sup> “Not applicable” because these functions are available only while the device is booting. See the BAM chapter of the *MPC5606BK Microcontroller Reference Manual* for details.
- <sup>7</sup> Value of PCR.IBE bit must be 0.
- <sup>8</sup> Out of reset all the functional pins except PC[0:1] and PH[9:10] are available to the user as GPIO. PC[0:1] are available as JTAG pins (TDI and TDO respectively). PH[9:10] are available as JTAG pins (TCK and TMS respectively). It is up to the user to configure these pins as GPIO when needed.
- <sup>9</sup> PC[1] is a fast/medium pad but is in medium configuration by default. This pad is in Alternate Function 2 mode after reset which has TDO functionality. The reset value of PCR.OBE is 1, but this setting has no impact as long as this pad stays in AF2 mode. After configuring this pad as GPIO (PCR.PA = 0), output buffer is enabled as reset value of PCR.OBE = 1.
- <sup>10</sup> Not available in 100LQFP package.

**Table 3. Pad types**

Type	Description
F	Fast
I	Input only with analog feature
J	Input/output with analog feature
M	Medium
S	Slow

## 3 Electrical characteristics

This section contains electrical characteristics of the device as well as temperature and power considerations.

This product contains devices to protect the inputs against damage due to high static voltages. However, it is advisable to take precautions to avoid application of any voltage higher than the specified maximum rated voltages.

To enhance reliability, unused inputs can be driven to an appropriate logic voltage level ( $V_{DD}$  or  $V_{SS}$ ). This could be done by the internal pull-up and pull-down, which is provided by the product for most general purpose pins.

The parameters listed in the following tables represent the characteristics of the device and its demands on the system.

In the tables where the device logic provides signals with their respective timing characteristics, the symbol “CC” for Controller Characteristics is included in the Symbol column.

In the tables where the external system must provide signals with their respective timing characteristics to the device, the symbol “SR” for System Requirement is included in the Symbol column.

### 3.1 Parameter classification

The electrical parameters shown in this supplement are guaranteed by various methods. To give the customer a better understanding, the classifications listed in [Table 4](#) are used and the parameters are tagged accordingly in the tables where appropriate.

**Table 4. Parameter classifications**

Classification tag	Tag description
P	Those parameters are guaranteed during production testing on each individual device.
C	Those parameters are achieved by the design characterization by measuring a statistically relevant sample size across process variations.
T	Those parameters are achieved by design characterization on a small sample size from typical devices under typical conditions unless otherwise noted. All values shown in the typical column are within this category.
D	Those parameters are derived mainly from simulations.

**NOTE**

The classification is shown in the column labeled “C” in the parameter tables where appropriate.

## 3.2 NVUSRO register

Portions of the device configuration, such as high voltage supply, oscillator margin, and watchdog enable/disable after reset are controlled via bit values in the Non-Volatile User Options Register (NVUSRO) register.

For a detailed description of the NVUSRO register, please refer to the *MPC5606BK Microcontroller Reference Manual*.

### 3.2.1 NVUSRO[**PAD3V5V**] field description

Table 5 shows how NVUSRO[**PAD3V5V**] controls the device configuration.

**Table 5. PAD3V5V field description<sup>1</sup>**

Value <sup>2</sup>	Description
0	High voltage supply is 5.0 V
1	High voltage supply is 3.3 V

<sup>1</sup> See the *MPC5606BK Microcontroller Reference Manual* for more information on the NVUSRO register.

<sup>2</sup> The default manufacturing value is ‘1’. This value can be programmed by the customer in Shadow Flash.

The DC electrical characteristics are dependent on the **PAD3V5V** bit value.

### 3.2.2 NVUSRO[**OSCILLATOR\_MARGIN**] field description

Table 6 shows how NVUSRO[**OSCILLATOR\_MARGIN**] controls the device configuration.

**Table 6. OSCILLATOR\_MARGIN field description<sup>1</sup>**

Value <sup>2</sup>	Description
0	Low consumption configuration (4 MHz/8 MHz)
1	High margin configuration (4 MHz/16 MHz)

<sup>1</sup> See the *MPC5606BK Microcontroller Reference Manual* for more information on the NVUSRO register.

<sup>2</sup> The default manufacturing value is ‘1’. This value can be programmed by the customer in Shadow Flash.

The fast external crystal oscillator consumption is dependent on the **OSCILLATOR\_MARGIN** bit value.

### 3.2.3 NVUSRO[WATCHDOG\_EN] field description

The watchdog enable/disable configuration after reset is dependent on the WATCHDOG\_EN bit value. Table 7 shows how NVUSRO[WATCHDOG\_EN] controls the device configuration.

**Table 7. WATCHDOG\_EN field description<sup>1</sup>**

Value <sup>2</sup>	Description
0	Disable after reset
1	Enable after reset

<sup>1</sup> See the MPC5606BK Microcontroller Reference Manual for more information on the NVUSRO register.

<sup>2</sup> The default manufacturing value is '1'. This value can be programmed by the customer in Shadow Flash.

### 3.3 Absolute maximum ratings

**Table 8. Absolute maximum ratings**

Symbol	Parameter	Conditions	Value		Unit	
			Min	Max		
V <sub>SS</sub>	SR	Digital ground on VSS_HV pins	—	0	0	V
V <sub>DD</sub>	SR	Voltage on VDD_HV pins with respect to ground (V <sub>SS</sub> )	—	-0.3	6.0	V
V <sub>SS_LV</sub>	SR	Voltage on VSS_LV (low voltage digital supply) pins with respect to ground (V <sub>SS</sub> )	—	V <sub>SS</sub> - 0.1	V <sub>SS</sub> + 0.1	V
V <sub>DD_BV</sub>	SR	Voltage on VDD_BV pin (regulator supply) with respect to ground (V <sub>SS</sub> )	—	-0.3	6.0	V
			Relative to V <sub>DD</sub>	-0.3	V <sub>DD</sub> + 0.3	
V <sub>SS_ADC</sub>	SR	Voltage on VSS_HV_ADC0, VSS_HV_ADC1 (ADC reference) pin with respect to ground (V <sub>SS</sub> )	—	V <sub>SS</sub> - 0.1	V <sub>SS</sub> + 0.1	V
V <sub>DD_ADC</sub>	SR	Voltage on VDD_HV_ADC0, VDD_HV_ADC1 (ADC reference) with respect to ground (V <sub>SS</sub> )	—	-0.3	6.0	V
			Relative to V <sub>DD</sub>	V <sub>DD</sub> - 0.3	V <sub>DD</sub> + 0.3	
V <sub>IN</sub>	SR	Voltage on any GPIO pin with respect to ground (V <sub>SS</sub> )	—	-0.3	6.0	V
			Relative to V <sub>DD</sub>	—	V <sub>DD</sub> + 0.3	
I <sub>INJPAD</sub>	SR	Injected input current on any pin during overload condition	—	-10	10	mA
I <sub>INJSUM</sub>	SR	Absolute sum of all injected input currents during overload condition	—	-50	50	
I <sub>AVGSEG</sub>	SR	Sum of all the static I/O current within a supply segment	V <sub>DD</sub> = 5.0 V ± 10%, PAD3V5V = 0	—	70	mA
			V <sub>DD</sub> = 3.3 V ± 10%, PAD3V5V = 1	—	64	
T <sub>STORAGE</sub>	SR	Storage temperature	—	-55	150	°C

## NOTE

Stresses exceeding the recommended absolute maximum ratings may cause permanent damage to the device. This is a stress rating only and functional operation of the device at these or any other conditions above those indicated in the operational sections of this specification are not implied. Exposure to absolute maximum rating conditions for extended periods may affect device reliability. During overload conditions ( $V_{IN} > V_{DD}$  or  $V_{IN} < V_{SS}$ ), the voltage on pins with respect to ground ( $V_{SS}$ ) must not exceed the recommended values.

### 3.4 Recommended operating conditions

Table 9. Recommended operating conditions (3.3 V)

Symbol		Parameter	Conditions	Value		Unit
				Min	Max	
$V_{SS}$	SR	Digital ground on VSS_HV pins	—	0	0	V
$V_{DD}^1$	SR	Voltage on VDD_HV pins with respect to ground ( $V_{SS}$ )	—	3.0	3.6	V
$V_{SS\_LV}^2$	SR	Voltage on VSS_LV (low voltage digital supply) pins with respect to ground ( $V_{SS}$ )	—	$V_{SS} - 0.1$	$V_{SS} + 0.1$	V
$V_{DD\_BV}^3$	SR	Voltage on VDD_BV pin (regulator supply) with respect to ground ( $V_{SS}$ )	—	3.0	3.6	V
			Relative to $V_{DD}$	$V_{DD} - 0.1$	$V_{DD} + 0.1$	
$V_{SS\_ADC}$	SR	Voltage on VSS_HV_ADC0, VSS_HV_ADC1 (ADC reference) pin with respect to ground ( $V_{SS}$ )	—	$V_{SS} - 0.1$	$V_{SS} + 0.1$	V
$V_{DD\_ADC}^4$	SR	Voltage on VDD_HV_ADC0, VDD_HV_ADC1 (ADC reference) with respect to ground ( $V_{SS}$ )	—	$3.0^5$	3.6	V
			Relative to $V_{DD}$	$V_{DD} - 0.1$	$V_{DD} + 0.1$	
$V_{IN}$	SR	Voltage on any GPIO pin with respect to ground ( $V_{SS}$ )	—	$V_{SS} - 0.1$	—	V
			Relative to $V_{DD}$	—	$V_{DD} + 0.1$	
$I_{INPAD}$	SR	Injected input current on any pin during overload condition	—	-5	5	mA
$I_{INJSUM}$	SR	Absolute sum of all injected input currents during overload condition	—	-50	50	
$TV_{DD}$	SR	$V_{DD}$ slope to ensure correct power up <sup>6</sup>	—	$3.0^7$	0.25 V/ $\mu$ s	V/s

**Table 9. Recommended operating conditions (3.3 V) (continued)**

Symbol		Parameter	Conditions	Value		Unit
				Min	Max	
$T_{A\ C\text{-Grade}}$ Part	SR	Ambient temperature under bias	$f_{\text{CPU}} < 64\ \text{MHz}^8$	-40	85	°C
$T_{J\ C\text{-Grade}}$ Part	SR	Junction temperature under bias	—	-40	110	
$T_{A\ V\text{-Grade}}$ Part	SR	Ambient temperature under bias	$f_{\text{CPU}} < 64\ \text{MHz}^8$	-40	105	
$T_{J\ V\text{-Grade}}$ Part	SR	Junction temperature under bias	—	-40	130	
$T_{A\ M\text{-Grade}}$ Part	SR	Ambient temperature under bias	$f_{\text{CPU}} < 64\ \text{MHz}^8$	-40	125	
$T_{J\ M\text{-Grade}}$ Part	SR	Junction temperature under bias	—	-40	150	

<sup>1</sup> 100 nF capacitance needs to be provided between each  $V_{\text{DD}}/V_{\text{SS}}$  pair.

<sup>2</sup> 330 nF capacitance needs to be provided between each  $V_{\text{DD\_LV}}/V_{\text{SS\_LV}}$  supply pair.

<sup>3</sup> 470 nF capacitance needs to be provided between  $V_{\text{DD\_BV}}$  and the nearest  $V_{\text{SS\_LV}}$  (higher value may be needed depending on external regulator characteristics). Supply ramp slope on  $V_{\text{DD\_BV}}$  should always be faster or equal to slope of  $V_{\text{DD\_HV}}$ . Otherwise, device may enter regulator bypass mode if slope on  $V_{\text{DD\_BV}}$  is slower.

<sup>4</sup> 100 nF capacitance needs to be provided between  $V_{\text{DD\_ADC}}/V_{\text{SS\_ADC}}$  pair.

<sup>5</sup> Full electrical specification cannot be guaranteed when voltage drops below 3.0 V. In particular, ADC electrical characteristics and I/O DC electrical specification may not be guaranteed. When voltage drops below  $V_{\text{LVdHVL}}$ , the device is reset.

<sup>6</sup> Guaranteed by device validation

<sup>7</sup> Minimum value of  $T_{\text{VDD}}$  must be guaranteed until  $V_{\text{DD}}$  reaches 2.6 V (maximum value of  $V_{\text{PORH}}$ ).

<sup>8</sup> This frequency includes the 4% frequency modulation guard band.

**Table 10. Recommended operating conditions (5.0 V)**

Symbol		Parameter	Conditions	Value		Unit
				Min	Max	
$V_{\text{SS}}$	SR	Digital ground on $V_{\text{SS\_HV}}$ pins	—	0	0	V
$V_{\text{DD}}^1$	SR	Voltage on $V_{\text{DD\_HV}}$ pins with respect to ground ( $V_{\text{SS}}$ )	—	4.5	5.5	V
			Voltage drop <sup>2</sup>	3.0	5.5	
$V_{\text{SS\_LV}}^3$	SR	Voltage on $V_{\text{SS\_LV}}$ (low voltage digital supply) pins with respect to ground ( $V_{\text{SS}}$ )	—	$V_{\text{SS}} - 0.1$	$V_{\text{SS}} + 0.1$	V
$V_{\text{DD\_BV}}^4$	SR	Voltage on $V_{\text{DD\_BV}}$ pin (regulator supply) with respect to ground ( $V_{\text{SS}}$ )	—	4.5	5.5	V
			Voltage drop <sup>2</sup>	3.0	5.5	
			Relative to $V_{\text{DD}}$	3.0	$V_{\text{DD}} + 0.1$	
$V_{\text{SS\_ADC}}$	SR	Voltage on $V_{\text{SS\_HV\_ADC0}}$ , $V_{\text{SS\_HV\_ADC1}}$ (ADC reference) pin with respect to ground ( $V_{\text{SS}}$ )	—	$V_{\text{SS}} - 0.1$	$V_{\text{SS}} + 0.1$	V

**Table 10. Recommended operating conditions (5.0 V) (continued)**

Symbol	Parameter	Conditions	Value		Unit	
			Min	Max		
$V_{DD\_ADC}$ <sup>5</sup>	SR	Voltage on VDD_HV_ADC0, VDD_HV_ADC1 (ADC reference) with respect to ground ( $V_{SS}$ )	—	4.5	5.5	V
			Voltage drop <sup>2</sup>	3.0	5.5	
			Relative to $V_{DD}$	$V_{DD} - 0.1$	$V_{DD} + 0.1$	
$V_{IN}$	SR	Voltage on any GPIO pin with respect to ground ( $V_{SS}$ )	—	$V_{SS} - 0.1$	—	V
			Relative to $V_{DD}$	—	$V_{DD} + 0.1$	
$I_{INJPAD}$	SR	Injected input current on any pin during overload condition	—	-5	5	mA
$I_{INJSUM}$	SR	Absolute sum of all injected input currents during overload condition	—	-50	50	
$TV_{DD}$	SR	$V_{DD}$ slope to ensure correct power up <sup>6</sup>	—	3.0 <sup>7</sup>	0.25 V/ $\mu$ s	V/s
$T_{A\ C-Grade\ Part}$	SR	Ambient temperature under bias	$f_{CPU} < 64\ MHz$ <sup>8</sup>	-40	85	°C
$T_{J\ C-Grade\ Part}$	SR	Junction temperature under bias	—	-40	110	
$T_{A\ V-Grade\ Part}$	SR	Ambient temperature under bias	$f_{CPU} < 64\ MHz$ <sup>8</sup>	-40	105	
$T_{J\ V-Grade\ Part}$	SR	Junction temperature under bias	—	-40	130	
$T_{A\ M-Grade\ Part}$	SR	Ambient temperature under bias	$f_{CPU} < 64\ MHz$ <sup>8</sup>	-40	125	
$T_{J\ M-Grade\ Part}$	SR	Junction temperature under bias	—	-40	150	

<sup>1</sup> 100 nF capacitance needs to be provided between each  $V_{DD}/V_{SS}$  pair.

<sup>2</sup> Full device operation is guaranteed by design when the voltage drops below 4.5 V down to 3.0 V. However, certain analog electrical characteristics will not be guaranteed to stay within the stated limits.

<sup>3</sup> 330 nF capacitance needs to be provided between each  $V_{DD\_LV}/V_{SS\_LV}$  supply pair.

<sup>4</sup> 470 nF capacitance needs to be provided between  $V_{DD\_BV}$  and the nearest  $V_{SS\_LV}$  (higher value may be needed depending on external regulator characteristics). While the supply voltage ramps up, the slope on  $V_{DD\_BV}$  should be less than  $0.9V_{DD\_HV}$  in order to ensure the device does not enter regulator bypass mode.

<sup>5</sup> 100 nF capacitance needs to be provided between  $V_{DD\_ADC}/V_{SS\_ADC}$  pair.

<sup>6</sup> Guaranteed by device validation. Please refer to [Section 3.5.1, External ballast resistor recommendations](#) for minimum  $V_{DD}$  slope to be guaranteed to ensure correct power up in case of external resistor usage.

<sup>7</sup> Minimum value of  $TV_{DD}$  must be guaranteed until  $V_{DD}$  reaches 2.6 V (maximum value of  $V_{PORH}$ ).

<sup>8</sup> This frequency includes the 4% frequency modulation guard band.

## NOTE

RAM data retention is guaranteed with  $V_{DD\_LV}$  not below 1.08 V.

## 3.5 Thermal characteristics

### 3.5.1 External ballast resistor recommendations

External ballast resistor on  $V_{DD\_BV}$  pin helps in reducing the overall power dissipation inside the device. This resistor is required only when maximum power consumption exceeds the limit imposed by package thermal characteristics.

As stated in [Table 11](#) LQFP thermal characteristics, considering a thermal resistance of 144 LQFP as 48.3 °C/W, at ambient temperature  $T_A = 125$  °C, the junction temperature  $T_j$  will cross 150 °C if the total power dissipation is greater than  $(150 - 125)/48.3 = 517$  mW. Therefore, the total device current  $I_{DDMAX}$  at 125 °C/5.5 V must not exceed 94.1 mA (i.e., PD/VDD). Assuming an average  $I_{DD}(V_{DD\_HV})$  of 15–20 mA consumption typically during device RUN mode, the LV domain consumption  $I_{DD}(V_{DD\_BV})$  is thus limited to  $I_{DDMAX} - I_{DD}(V_{DD\_HV})$ , i.e., 80 mA.

Therefore, respecting the maximum power allowed as explained in [Section 3.5.2, Package thermal characteristics](#), it is recommended to use this resistor only in the 125 °C/5.5 V operating corner as per the following guidelines:

- If  $I_{DD}(V_{DD\_BV}) < 80$  mA, then no resistor is required.
- If  $80 \text{ mA} < I_{DD}(V_{DD\_BV}) < 90$  mA, then 4 Ω resistor can be used.
- If  $I_{DD}(V_{DD\_BV}) > 90$  mA, then 8 Ω resistor can be used.

Using resistance in the range of 4–8 Ω, the gain will be around 10–20% of total consumption on  $V_{DD\_BV}$ . For example, if 8 Ω resistor is used, then power consumption when  $I_{DD}(V_{DD\_BV})$  is 110 mA is equivalent to power consumption when  $I_{DD}(V_{DD\_BV})$  is 90 mA (approximately) when resistor not used.

In order to ensure correct power up, the minimum  $V_{DD\_BV}$  to be guaranteed is 30 mV. If the supply ramp is slower than this value, then LVDHV3B monitoring ballast supply  $V_{DD\_BV}$  pin gets triggered leading to device reset. Until the supply reaches certain threshold, this low voltage monitor generates destructive reset event in the system. This threshold depends on the maximum  $I_{DD}(V_{DD\_BV})$  possible across the external resistor.

### 3.5.2 Package thermal characteristics

Table 11. LQFP thermal characteristics<sup>1</sup>

Symbol	C	Parameter	Conditions <sup>2</sup>	Pin count	Value			Unit
					Min	Typ	Max	
$R_{\theta JA}$	CC	Thermal resistance, junction-to-ambient natural convection <sup>3</sup>	Single-layer board — 1s	100	—	—	64	°C/W
				144	—	—	64	
				176	—	—	64	
			Four-layer board — 2s2p	100	—	—	49.7	
				144	—	—	48.3	
				176	—	—	47.3	
$R_{\theta JB}$	CC	Thermal resistance, junction-to-board <sup>4</sup>	Single-layer board — 1s	100	—	—	36	°C/W
				144	—	—	38	
				176	—	—	38	
			Four-layer board — 2s2p	100	—	—	33.6	
				144	—	—	33.4	
				176	—	—	33.4	

**Table 11. LQFP thermal characteristics<sup>1</sup> (continued)**

Symbol	C	Parameter	Conditions <sup>2</sup>	Pin count	Value			Unit
					Min	Typ	Max	
R <sub>θJC</sub>	CC	Thermal resistance, junction-to-case <sup>5</sup>	Single-layer board — 1s	100	—	—	23	°C/W
				144	—	—	23	
				176	—	—	23	
			Four-layer board — 2s2p	100	—	—	19.8	
				144	—	—	19.2	
				176	—	—	18.8	

<sup>1</sup> Thermal characteristics are targets based on simulation.

<sup>2</sup> V<sub>DD</sub> = 3.3 V ± 10% / 5.0 V ± 10%, T<sub>A</sub> = -40 to 125 °C.

<sup>3</sup> Junction-to-ambient thermal resistance determined per JEDEC JESD51-3 and JESD51-6. Thermal test board meets JEDEC specification for this package. When Greek letters are not available, the symbols are typed as R<sub>thJA</sub> and R<sub>thJMA</sub>.

<sup>4</sup> Junction-to-board thermal resistance determined per JEDEC JESD51-8. Thermal test board meets JEDEC specification for the specified package. When Greek letters are not available, the symbols are typed as R<sub>thJB</sub>.

<sup>5</sup> Junction-to-case at the top of the package determined using MIL-STD 883 Method 1012.1. The cold plate temperature is used for the case temperature. Reported value includes the thermal resistance of the interface layer. When Greek letters are not available, the symbols are typed as R<sub>thJC</sub>.

### 3.5.3 Power considerations

The average chip-junction temperature, T<sub>J</sub>, in degrees Celsius, may be calculated using [Equation 1](#):

$$T_J = T_A + (P_D \times R_{\theta JA}) \quad \text{Eqn. 1}$$

Where:

T<sub>A</sub> is the ambient temperature in °C.

R<sub>θJA</sub> is the package junction-to-ambient thermal resistance, in °C/W.

P<sub>D</sub> is the sum of P<sub>INT</sub> and P<sub>I/O</sub> (P<sub>D</sub> = P<sub>INT</sub> + P<sub>I/O</sub>).

P<sub>INT</sub> is the product of I<sub>DD</sub> and V<sub>DD</sub>, expressed in watts. This is the chip internal power.

P<sub>I/O</sub> represents the power dissipation on input and output pins; user determined.

Most of the time for the applications, P<sub>I/O</sub> < P<sub>INT</sub> and may be neglected. On the other hand, P<sub>I/O</sub> may be significant, if the device is configured to continuously drive external modules and/or memories.

An approximate relationship between P<sub>D</sub> and T<sub>J</sub> (if P<sub>I/O</sub> is neglected) is given by:

$$P_D = K / (T_J + 273 \text{ °C}) \quad \text{Eqn. 2}$$

Therefore, solving equations 1 and 2:

$$K = P_D \times (T_A + 273 \text{ °C}) + R_{\theta JA} \times P_D^2 \quad \text{Eqn. 3}$$

Where:

K is a constant for the particular part, which may be determined from [Equation 3](#) by measuring  $P_D$  (at equilibrium) for a known  $T_A$ . Using this value of K, the values of  $P_D$  and  $T_J$  may be obtained by solving equations [1](#) and [2](#) iteratively for any value of  $T_A$ .

## 3.6 I/O pad electrical characteristics

### 3.6.1 I/O pad types

The device provides four main I/O pad types depending on the associated alternate functions:

- Slow pads — are the most common pads, providing a good compromise between transition time and low electromagnetic emission.
- Medium pads — provide transition fast enough for the serial communication channels with controlled current to reduce electromagnetic emission.
- Fast pads — provide maximum speed. These are used for improved debugging capability.
- Input only pads — are associated with ADC channels and 32 kHz low power external crystal oscillator providing low input leakage.

Medium and Fast pads can use slow configuration to reduce electromagnetic emission, at the cost of reducing AC performance.

### 3.6.2 I/O input DC characteristics

[Table 12](#) provides input DC electrical characteristics as described in [Figure 5](#).

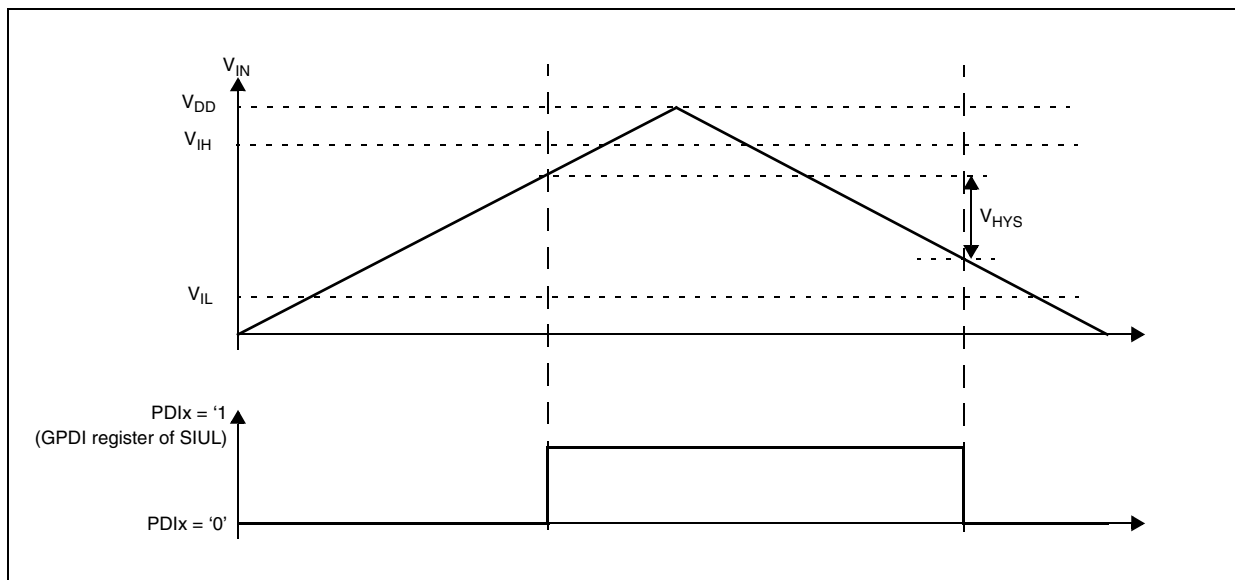

**Figure 5. I/O input DC electrical characteristics definition**

**Table 12. I/O input DC electrical characteristics**

Symbol	C	Parameter	Conditions <sup>1</sup>	Value			Unit		
				Min	Typ	Max			
V <sub>IH</sub>	SR	P	Input high level CMOS (Schmitt Trigger)	—	—	V <sub>DD</sub> + 0.4	V		
V <sub>IL</sub>	SR	P	Input low level CMOS (Schmitt Trigger)	—	—	0.35V <sub>DD</sub>			
V <sub>HYS</sub>	CC	C	Input hysteresis CMOS (Schmitt Trigger)	—	—	—			
I <sub>LKG</sub>	CC	P	Digital input leakage	No injection on adjacent pin	T <sub>A</sub> = -40 °C	—	2	—	nA
					T <sub>A</sub> = 25 °C	—	2	—	
					T <sub>A</sub> = 85 °C	—	5	300	
					T <sub>A</sub> = 105 °C	—	12	500	
					T <sub>A</sub> = 125 °C	—	70	1000	
W <sub>FI</sub> <sup>2</sup>	SR	P	Wakeup input filtered pulse	—	—	40	ns		
W <sub>NFI</sub> <sup>2</sup>	SR	P	Wakeup input not filtered pulse	—	1000	—	ns		

<sup>1</sup> V<sub>DD</sub> = 3.3 V ± 10% / 5.0 V ± 10%, T<sub>A</sub> = -40 to 125 °C, unless otherwise specified

<sup>2</sup> In the range from 40 to 1000 ns, pulses can be filtered or not filtered, according to operating temperature and voltage.

### 3.6.3 I/O output DC characteristics

The following tables provide DC characteristics for bidirectional pads:

- [Table 13](#) provides weak pull figures. Both pull-up and pull-down resistances are supported.
- [Table 14](#) provides output driver characteristics for I/O pads when in SLOW configuration.
- [Table 15](#) provides output driver characteristics for I/O pads when in MEDIUM configuration.
- [Table 16](#) provides output driver characteristics for I/O pads when in FAST configuration.

**Table 13. I/O pull-up/pull-down DC electrical characteristics**

Symbol	C	Parameter	Conditions <sup>1</sup>	Value			Unit		
				Min	Typ	Max			
I <sub>WPUL</sub>	CC	P	Weak pull-up current absolute value	V <sub>IN</sub> = V <sub>IL</sub> , V <sub>DD</sub> = 5.0 V ± 10%	PAD3V5V = 0	10	—	150	μA
					PAD3V5V = 1 <sup>2</sup>	10	—	250	
				V <sub>IN</sub> = V <sub>IL</sub> , V <sub>DD</sub> = 3.3 V ± 10%	PAD3V5V = 1	10	—	150	
I <sub>WPD</sub>	CC	P	Weak pull-down current absolute value	V <sub>IN</sub> = V <sub>IH</sub> , V <sub>DD</sub> = 5.0 V ± 10%	PAD3V5V = 0	10	—	150	μA
					PAD3V5V = 1	10	—	250	
				V <sub>IN</sub> = V <sub>IH</sub> , V <sub>DD</sub> = 3.3 V ± 10%	PAD3V5V = 1	10	—	150	

<sup>1</sup> V<sub>DD</sub> = 3.3 V ± 10% / 5.0 V ± 10%, T<sub>A</sub> = -40 to 125 °C, unless otherwise specified.

<sup>2</sup> The configuration PAD3V5 = 1 when V<sub>DD</sub> = 5 V is only a transient configuration during power-up. All pads but RESET are configured in input or in high impedance state.

**Table 14. SLOW configuration output buffer electrical characteristics**

Symbol	C	Parameter	Conditions <sup>1</sup>	Value			Unit		
				Min	Typ	Max			
V <sub>OH</sub>	CC	P	Output high level SLOW configuration	Push Pull	I <sub>OH</sub> = -2 mA, V <sub>DD</sub> = 5.0 V ± 10%, PAD3V5V = 0 (recommended)	0.8V <sub>DD</sub>	—	—	V
					I <sub>OH</sub> = -2 mA, V <sub>DD</sub> = 5.0 V ± 10%, PAD3V5V = 1 <sup>2</sup>	0.8V <sub>DD</sub>	—	—	
					I <sub>OH</sub> = -1 mA, V <sub>DD</sub> = 3.3 V ± 10%, PAD3V5V = 1 (recommended)	V <sub>DD</sub> - 0.8	—	—	
V <sub>OL</sub>	CC	P	Output low level SLOW configuration	Push Pull	I <sub>OL</sub> = 2 mA, V <sub>DD</sub> = 5.0 V ± 10%, PAD3V5V = 0 (recommended)	—	—	0.1V <sub>DD</sub>	V
					I <sub>OL</sub> = 2 mA, V <sub>DD</sub> = 5.0 V ± 10%, PAD3V5V = 1 <sup>2</sup>	—	—	0.1V <sub>DD</sub>	
					I <sub>OL</sub> = 1 mA, V <sub>DD</sub> = 3.3 V ± 10%, PAD3V5V = 1 (recommended)	—	—	0.5	

<sup>1</sup> V<sub>DD</sub> = 3.3 V ± 10% / 5.0 V ± 10%, T<sub>A</sub> = -40 to 125 °C, unless otherwise specified

<sup>2</sup> The configuration PAD3V5 = 1 when V<sub>DD</sub> = 5 V is only a transient configuration during power-up. All pads but RESET are configured in input or in high impedance state.

**Table 15. MEDIUM configuration output buffer electrical characteristics**

Symbol	C	Parameter	Conditions <sup>1</sup>	Value			Unit		
				Min	Typ	Max			
V <sub>OH</sub>	CC	C	Output high level MEDIUM configuration	Push Pull	I <sub>OH</sub> = -3.8 mA, V <sub>DD</sub> = 5.0 V ± 10%, PAD3V5V = 0	0.8V <sub>DD</sub>	—	—	V
					I <sub>OH</sub> = -2 mA, V <sub>DD</sub> = 5.0 V ± 10%, PAD3V5V = 0 (recommended)	0.8V <sub>DD</sub>	—	—	
					I <sub>OH</sub> = -1 mA, V <sub>DD</sub> = 5.0 V ± 10%, PAD3V5V = 1 <sup>2</sup>	0.8V <sub>DD</sub>	—	—	
					I <sub>OH</sub> = -1 mA, V <sub>DD</sub> = 3.3 V ± 10%, PAD3V5V = 1 (recommended)	V <sub>DD</sub> - 0.8	—	—	
					I <sub>OH</sub> = -100 μA, V <sub>DD</sub> = 5.0 V ± 10%, PAD3V5V = 0	0.8V <sub>DD</sub>	—	—	

**Table 15. MEDIUM configuration output buffer electrical characteristics (continued)**

Symbol	C	Parameter	Conditions <sup>1</sup>	Value			Unit		
				Min	Typ	Max			
V <sub>OL</sub>	CC	C	Output low level MEDIUM configuration	Push Pull	I <sub>OL</sub> = 3.8 mA, V <sub>DD</sub> = 5.0 V ± 10%, PAD3V5V = 0	—	—	0.2V <sub>DD</sub>	V
					I <sub>OL</sub> = 2 mA, V <sub>DD</sub> = 5.0 V ± 10%, PAD3V5V = 0 (recommended)	—	—	0.1V <sub>DD</sub>	
					I <sub>OL</sub> = 1 mA, V <sub>DD</sub> = 5.0 V ± 10%, PAD3V5V = 1 <sup>2</sup>	—	—	0.1V <sub>DD</sub>	
					I <sub>OL</sub> = 1 mA, V <sub>DD</sub> = 3.3 V ± 10%, PAD3V5V = 1 (recommended)	—	—	0.5	
					I <sub>OL</sub> = 100 μA, V <sub>DD</sub> = 5.0 V ± 10%, PAD3V5V = 0	—	—	0.1V <sub>DD</sub>	

<sup>1</sup> V<sub>DD</sub> = 3.3 V ± 10% / 5.0 V ± 10%, T<sub>A</sub> = -40 to 125 °C, unless otherwise specified

<sup>2</sup> The configuration PAD3V5 = 1 when V<sub>DD</sub> = 5 V is only a transient configuration during power-up. All pads but RESET are configured in input or in high impedance state.

**Table 16. FAST configuration output buffer electrical characteristics**

Symbol	C	Parameter	Conditions <sup>1</sup>	Value			Unit		
				Min	Typ	Max			
V <sub>OH</sub>	CC	P	Output high level FAST configuration	Push Pull	I <sub>OH</sub> = -14 mA, V <sub>DD</sub> = 5.0 V ± 10%, PAD3V5V = 0 (recommended)	0.8V <sub>DD</sub>	—	—	V
					I <sub>OH</sub> = -7 mA, V <sub>DD</sub> = 5.0 V ± 10%, PAD3V5V = 1 <sup>2</sup>	0.8V <sub>DD</sub>	—	—	
					I <sub>OH</sub> = -11 mA, V <sub>DD</sub> = 3.3 V ± 10%, PAD3V5V = 1 (recommended)	V <sub>DD</sub> - 0.8	—	—	
V <sub>OL</sub>	CC	P	Output low level FAST configuration	Push Pull	I <sub>OL</sub> = 14 mA, V <sub>DD</sub> = 5.0 V ± 10%, PAD3V5V = 0 (recommended)	—	—	0.1V <sub>DD</sub>	V
					I <sub>OL</sub> = 7 mA, V <sub>DD</sub> = 5.0 V ± 10%, PAD3V5V = 1 <sup>2</sup>	—	—	0.1V <sub>DD</sub>	
					I <sub>OL</sub> = 11 mA, V <sub>DD</sub> = 3.3 V ± 10%, PAD3V5V = 1 (recommended)	—	—	0.5	

<sup>1</sup> V<sub>DD</sub> = 3.3 V ± 10% / 5.0 V ± 10%, T<sub>A</sub> = -40 to 125 °C, unless otherwise specified

<sup>2</sup> The configuration PAD3V5 = 1 when  $V_{DD} = 5\text{ V}$  is only a transient configuration during power-up. All pads but RESET are configured in input or in high impedance state.

### 3.6.4 Output pin transition times

Table 17. Output pin transition times

Symbol	C	Parameter	Conditions <sup>1</sup>	Value			Unit	
				Min	Typ	Max		
$T_{tr}$	CC	Output transition time output pin <sup>2</sup> SLOW configuration	$C_L = 25\text{ pF}$	$V_{DD} = 5.0\text{ V} \pm 10\%$ , PAD3V5V = 0	—	—	50	ns
			$C_L = 50\text{ pF}$		—	—	100	
			$C_L = 100\text{ pF}$		—	—	125	
			$C_L = 25\text{ pF}$	$V_{DD} = 3.3\text{ V} \pm 10\%$ , PAD3V5V = 1	—	—	50	
			$C_L = 50\text{ pF}$		—	—	100	
			$C_L = 100\text{ pF}$		—	—	125	
$T_{tr}$	CC	Output transition time output pin <sup>2</sup> MEDIUM configuration	$C_L = 25\text{ pF}$	$V_{DD} = 5.0\text{ V} \pm 10\%$ , PAD3V5V = 0 SIUL.PCRx.SRC = 1	—	—	10	ns
			$C_L = 50\text{ pF}$		—	—	20	
			$C_L = 100\text{ pF}$		—	—	40	
			$C_L = 25\text{ pF}$	$V_{DD} = 3.3\text{ V} \pm 10\%$ , PAD3V5V = 1 SIUL.PCRx.SRC = 1	—	—	12	
			$C_L = 50\text{ pF}$		—	—	25	
			$C_L = 100\text{ pF}$		—	—	40	
$T_{tr}$	CC	Output transition time output pin <sup>2</sup> FAST configuration	$C_L = 25\text{ pF}$	$V_{DD} = 5.0\text{ V} \pm 10\%$ , PAD3V5V = 0	—	—	4	ns
			$C_L = 50\text{ pF}$		—	—	6	
			$C_L = 100\text{ pF}$		—	—	12	
			$C_L = 25\text{ pF}$	$V_{DD} = 3.3\text{ V} \pm 10\%$ , PAD3V5V = 1	—	—	4	
			$C_L = 50\text{ pF}$		—	—	7	
			$C_L = 100\text{ pF}$		—	—	12	

<sup>1</sup>  $V_{DD} = 3.3\text{ V} \pm 10\% / 5.0\text{ V} \pm 10\%$ ,  $T_A = -40\text{ to }125\text{ }^\circ\text{C}$ , unless otherwise specified

<sup>2</sup>  $C_L$  includes device and package capacitances ( $C_{PKG} < 5\text{ pF}$ ).

### 3.6.5 I/O pad current specification

The I/O pads are distributed across the I/O supply segment. Each I/O supply segment is associated to a  $V_{DD}/V_{SS}$  supply pair as described in Table 18.

Table 19 provides I/O consumption figures.

In order to ensure device reliability, the average current of the I/O on a single segment should remain below the  $I_{AVGSEG}$  maximum value.

**Table 18. I/O supply segments**

Package	Supply segment							
	1	2	3	4	5	6	7	8
176 LQFP	pin7 – pin27	pin28 – pin57	pin59 – pin85	pin86 – pin123	pin124 – pin150	pin151 – pin6	—	—
144 LQFP	pin20 – pin49	pin51 – pin99	pin100 – pin122	pin 123 – pin19	—	—	—	—
100 LQFP	pin16 – pin35	pin37 – pin69	pin70 – pin83	pin84 – pin15	—	—	—	—

**Table 19. I/O consumption**

Symbol	C	Parameter	Conditions <sup>1</sup>		Value			Unit	
					Min	Typ	Max		
I <sub>SWTSLW</sub> <sup>2</sup>	CC	D	Dynamic I/O current for SLOW configuration	C <sub>L</sub> = 25 pF	V <sub>DD</sub> = 5.0 V ± 10%, PAD3V5V = 0	—	—	20	mA
					V <sub>DD</sub> = 3.3 V ± 10%, PAD3V5V = 1	—	—	16	
I <sub>SWTMED</sub> <sup>2</sup>	CC	D	Dynamic I/O current for MEDIUM configuration	C <sub>L</sub> = 25 pF	V <sub>DD</sub> = 5.0 V ± 10%, PAD3V5V = 0	—	—	29	mA
					V <sub>DD</sub> = 3.3 V ± 10%, PAD3V5V = 1	—	—	17	
I <sub>SWTFST</sub> <sup>2</sup>	CC	D	Dynamic I/O current for FAST configuration	C <sub>L</sub> = 25 pF	V <sub>DD</sub> = 5.0 V ± 10%, PAD3V5V = 0	—	—	110	mA
					V <sub>DD</sub> = 3.3 V ± 10%, PAD3V5V = 1	—	—	50	
I <sub>RMSLW</sub>	CC	D	Root medium square I/O current for SLOW configuration	C <sub>L</sub> = 25 pF, 2 MHz	V <sub>DD</sub> = 5.0 V ± 10%, PAD3V5V = 0	—	—	2.3	mA
				C <sub>L</sub> = 25 pF, 4 MHz		—	—	3.2	
				C <sub>L</sub> = 100 pF, 2 MHz		—	—	6.6	
				C <sub>L</sub> = 25 pF, 2 MHz	V <sub>DD</sub> = 3.3 V ± 10%, PAD3V5V = 1	—	—	1.6	
				C <sub>L</sub> = 25 pF, 4 MHz		—	—	2.3	
				C <sub>L</sub> = 100 pF, 2 MHz		—	—	4.7	
I <sub>RMSMED</sub>	CC	D	Root medium square I/O current for MEDIUM configuration	C <sub>L</sub> = 25 pF, 13 MHz	V <sub>DD</sub> = 5.0 V ± 10%, PAD3V5V = 0	—	—	6.6	mA
				C <sub>L</sub> = 25 pF, 40 MHz		—	—	13.4	
				C <sub>L</sub> = 100 pF, 13 MHz		—	—	18.3	
				C <sub>L</sub> = 25 pF, 13 MHz	V <sub>DD</sub> = 3.3 V ± 10%, PAD3V5V = 1	—	—	5	
				C <sub>L</sub> = 25 pF, 40 MHz		—	—	8.5	
				C <sub>L</sub> = 100 pF, 13 MHz		—	—	11	

**Table 19. I/O consumption (continued)**

Symbol	C	Parameter	Conditions <sup>1</sup>		Value			Unit	
					Min	Typ	Max		
I <sub>RMSFST</sub>	CC	D Root medium square I/O current for FAST configuration	C <sub>L</sub> = 25 pF, 40 MHz	V <sub>DD</sub> = 5.0 V ± 10%, PAD3V5V = 0	—	—	22	mA	
					C <sub>L</sub> = 25 pF, 64 MHz	—	—		33
					C <sub>L</sub> = 100 pF, 40 MHz	—	—		56
			C <sub>L</sub> = 25 pF, 40 MHz	V <sub>DD</sub> = 3.3 V ± 10%, PAD3V5V = 1	—	—	14		
					C <sub>L</sub> = 25 pF, 64 MHz	—	—		20
					C <sub>L</sub> = 100 pF, 40 MHz	—	—		35
I <sub>AVGSEG</sub>	SR	D Sum of all the static I/O current within a supply segment	V <sub>DD</sub> = 5.0 V ± 10%, PAD3V5V = 0		—	—	70	mA	
			V <sub>DD</sub> = 3.3 V ± 10%, PAD3V5V = 1		—	—	65		

<sup>1</sup> V<sub>DD</sub> = 3.3 V ± 10% / 5.0 V ± 10%, T<sub>A</sub> = -40 to 125 °C, unless otherwise specified

<sup>2</sup> Stated maximum values represent peak consumption that lasts only a few ns during I/O transition.

Table 20 provides the weight of concurrent switching I/Os.

In order to ensure device functionality, the sum of the weight of concurrent switching I/Os on a single segment should remain below the 100%.

**Table 20. I/O weight<sup>1</sup>**

Supply segment			Pad	176 LQFP				144/100 LQFP			
				Weight 5 V		Weight 3.3 V		Weight 5 V		Weight 3.3 V	
176 LQFP	144 LQFP	100 LQFP		SRC <sup>2</sup> = 0	SRC = 1	SRC = 0	SRC = 1	SRC = 0	SRC = 1	SRC = 0	SRC = 1
6	4	4	PB[3]	5%	—	6%	—	13%	—	15%	—
			PC[9]	4%	—	5%	—	13%	—	15%	—
			PC[14]	4%	—	4%	—	13%	—	15%	—
			PC[15]	3%	4%	4%	4%	12%	18%	15%	16%
			—	—	PJ[4]	3%	4%	3%	3%	—	—

Table 20. I/O weight<sup>1</sup> (continued)

Supply segment			Pad	176 LQFP				144/100 LQFP					
				Weight 5 V		Weight 3.3 V		Weight 5 V		Weight 3.3 V			
176 LQFP	144 LQFP	100 LQFP		SRC <sup>2</sup> = 0	SRC = 1	SRC = 0	SRC = 1	SRC = 0	SRC = 1	SRC = 0	SRC = 1		
1	—	—	PH[15]	2%	3%	3%	3%	—	—	—	—		
	—	—	PH[13]	3%	4%	3%	4%	—	—	—	—		
	—	—	PH[14]	3%	4%	4%	4%	—	—	—	—		
	—	—	PI[6]	4%	—	4%	—	—	—	—	—		
	—	—	PI[7]	4%	—	4%	—	—	—	—	—		
	4	—	—	PG[5]	4%	—	5%	—	10%	—	12%	—	
		—	—	PG[4]	4%	6%	5%	5%	9%	13%	11%	12%	
		—	—	PG[3]	4%	—	5%	—	9%	—	11%	—	
		—	—	PG[2]	4%	6%	5%	5%	9%	12%	10%	11%	
		4	—	—	PA[2]	4%	—	5%	—	8%	—	10%	—
			—	—	PE[0]	4%	—	5%	—	8%	—	9%	—
			—	—	PA[1]	4%	—	5%	—	8%	—	9%	—
			—	—	PE[1]	4%	6%	5%	6%	7%	10%	9%	9%
			—	—	PE[8]	4%	6%	5%	6%	7%	10%	8%	9%
			—	—	PE[9]	4%	—	5%	—	6%	—	8%	—
	—		—	PE[10]	4%	—	5%	—	6%	—	7%	—	
—	—		PA[0]	4%	6%	5%	5%	6%	8%	7%	7%		
—	—	PE[11]	4%	—	5%	—	5%	—	6%	—			

Table 20. I/O weight<sup>1</sup> (continued)

Supply segment			Pad	176 LQFP				144/100 LQFP			
				Weight 5 V		Weight 3.3 V		Weight 5 V		Weight 3.3 V	
176 LQFP	144 LQFP	100 LQFP		SRC <sup>2</sup> = 0	SRC = 1	SRC = 0	SRC = 1	SRC = 0	SRC = 1	SRC = 0	SRC = 1
2	1	—	PG[9]	9%	—	10%	—	9%	—	10%	—
		—	PG[8]	9%	—	11%	—	9%	—	11%	—
		1	PC[11]	9%	—	11%	—	9%	—	11%	—
			PC[10]	9%	13%	11%	12%	9%	13%	11%	12%
		—	PG[7]	9%	—	11%	—	9%	—	11%	—
		—	PG[6]	10%	14%	11%	12%	10%	14%	11%	12%
		1	PB[0]	10%	14%	12%	12%	10%	14%	12%	12%
			PB[1]	10%	—	12%	—	10%	—	12%	—
		—	PF[9]	10%	—	12%	—	10%	—	12%	—
		—	PF[8]	10%	14%	12%	13%	10%	14%	12%	13%
		—	PF[12]	10%	15%	12%	13%	10%	15%	12%	13%
		1	PC[6]	10%	—	12%	—	10%	—	12%	—
			PC[7]	10%	—	12%	—	10%	—	12%	—
		—	PF[10]	10%	14%	11%	12%	10%	14%	11%	12%
		—	PF[11]	9%	—	11%	—	9%	—	11%	—
		1	PA[15]	8%	12%	10%	10%	8%	12%	10%	10%
		—	PF[13]	8%	—	10%	—	8%	—	10%	—
		1	PA[14]	8%	11%	9%	10%	8%	11%	9%	10%
			PA[4]	7%	—	9%	—	7%	—	9%	—
			PA[13]	7%	10%	8%	9%	7%	10%	8%	9%
PA[12]	7%		—	8%	—	7%	—	8%	—		

Table 20. I/O weight<sup>1</sup> (continued)

Supply segment			Pad	176 LQFP				144/100 LQFP				
				Weight 5 V		Weight 3.3 V		Weight 5 V		Weight 3.3 V		
176 LQFP	144 LQFP	100 LQFP		SRC <sup>2</sup> = 0	SRC = 1	SRC = 0	SRC = 1	SRC = 0	SRC = 1	SRC = 0	SRC = 1	
3	2	2	PB[9]	1%	—	1%	—	1%	—	1%	—	
			PB[8]	1%	—	1%	—	1%	—	1%	—	
			PB[10]	5%	—	6%	—	6%	—	7%	—	
		—	—	PF[0]	5%	—	6%	—	6%	—	8%	—
		—	—	PF[1]	5%	—	6%	—	7%	—	8%	—
		—	—	PF[2]	6%	—	7%	—	7%	—	9%	—
		—	—	PF[3]	6%	—	7%	—	8%	—	9%	—
		—	—	PF[4]	6%	—	7%	—	8%	—	10%	—
		—	—	PF[5]	6%	—	7%	—	9%	—	10%	—
		—	—	PF[6]	6%	—	7%	—	9%	—	11%	—
	—	—	PF[7]	6%	—	7%	—	9%	—	11%	—	
	—	—	PJ[3]	6%	—	7%	—	—	—	—	—	
	—	—	PJ[2]	6%	—	7%	—	—	—	—	—	
	—	—	PJ[1]	6%	—	7%	—	—	—	—	—	
	—	—	PJ[0]	6%	—	7%	—	—	—	—	—	
	—	—	PI[15]	6%	—	7%	—	—	—	—	—	
	—	—	PI[14]	6%	—	7%	—	—	—	—	—	
	—	2	2	PD[0]	1%	—	1%	—	1%	—	1%	—
	—	—	—	PD[1]	1%	—	1%	—	1%	—	1%	—
	—	—	—	PD[2]	1%	—	1%	—	1%	—	1%	—
—	—	—	PD[3]	1%	—	1%	—	1%	—	1%	—	
—	—	—	PD[4]	1%	—	1%	—	1%	—	1%	—	
—	—	—	PD[5]	1%	—	1%	—	1%	—	1%	—	
—	—	—	PD[6]	1%	—	1%	—	1%	—	2%	—	
—	—	—	PD[7]	1%	—	1%	—	1%	—	2%	—	

Table 20. I/O weight<sup>1</sup> (continued)

Supply segment			Pad	176 LQFP				144/100 LQFP			
				Weight 5 V		Weight 3.3 V		Weight 5 V		Weight 3.3 V	
176 LQFP	144 LQFP	100 LQFP		SRC <sup>2</sup> = 0	SRC = 1	SRC = 0	SRC = 1	SRC = 0	SRC = 1	SRC = 0	SRC = 1
4	2	2	PD[8]	1%	—	1%	—	1%	—	2%	—
			PB[4]	1%	—	1%	—	1%	—	2%	—
			PB[5]	1%	—	1%	—	1%	—	2%	—
			PB[6]	1%	—	1%	—	1%	—	2%	—
			PB[7]	1%	—	1%	—	1%	—	2%	—
			PD[9]	1%	—	1%	—	1%	—	2%	—
			PD[10]	1%	—	1%	—	1%	—	2%	—
			PD[11]	1%	—	1%	—	1%	—	2%	—
4	—	—	PB[11]	1%	—	1%	—	—	—	—	—
	—	—	PD[12]	11%	—	13%	—	—	—	—	—
	2	2	PB[12]	11%	—	13%	—	15%	—	17%	—
			PD[13]	11%	—	13%	—	14%	—	17%	—
			PB[13]	11%	—	13%	—	14%	—	17%	—
			PD[14]	11%	—	13%	—	14%	—	17%	—
			PB[14]	11%	—	13%	—	14%	—	16%	—
			PD[15]	11%	—	13%	—	13%	—	16%	—
			PB[15]	11%	—	13%	—	13%	—	15%	—
	—	—	PI[8]	10%	—	12%	—	—	—	—	—
	—	—	PI[9]	10%	—	12%	—	—	—	—	—
	—	—	PI[10]	10%	—	12%	—	—	—	—	—
	—	—	PI[11]	10%	—	12%	—	—	—	—	—
	—	—	PI[12]	10%	—	12%	—	—	—	—	—
	—	—	PI[13]	10%	—	11%	—	—	—	—	—
	2	2	PA[3]	9%	—	11%	—	11%	—	13%	—
			PG[13]	9%	13%	11%	11%	10%	14%	12%	13%
			PG[12]	9%	13%	10%	11%	10%	14%	12%	12%
			PH[0]	6%	8%	7%	7%	6%	9%	7%	8%
			PH[1]	6%	8%	7%	7%	6%	8%	7%	7%
PH[2]			5%	7%	6%	6%	5%	7%	6%	7%	
PH[3]			5%	7%	5%	6%	5%	7%	6%	6%	
PG[1]			4%	—	5%	—	4%	—	5%	—	
—	—	PG[0]	4%	5%	4%	5%	4%	5%	4%	5%	

Table 20. I/O weight<sup>1</sup> (continued)

Supply segment			Pad	176 LQFP				144/100 LQFP			
				Weight 5 V		Weight 3.3 V		Weight 5 V		Weight 3.3 V	
176 LQFP	144 LQFP	100 LQFP		SRC <sup>2</sup> = 0	SRC = 1	SRC = 0	SRC = 1	SRC = 0	SRC = 1	SRC = 0	SRC = 1
5	3	—	PF[15]	4%	—	4%	—	4%	—	4%	—
		—	PF[14]	4%	6%	5%	5%	4%	6%	5%	5%
		—	PE[13]	4%	—	5%	—	4%	—	5%	—
		3	PA[7]	5%	—	6%	—	5%	—	6%	—
			PA[8]	5%	—	6%	—	5%	—	6%	—
			PA[9]	6%	—	7%	—	6%	—	7%	—
			PA[10]	6%	—	8%	—	6%	—	8%	—
			PA[11]	8%	—	9%	—	8%	—	9%	—
			PE[12]	8%	—	9%	—	8%	—	9%	—
			—	PG[14]	8%	—	9%	—	8%	—	9%
		—	PG[15]	8%	11%	9%	10%	8%	11%	9%	10%
		—	PE[14]	8%	—	9%	—	8%	—	9%	—
		—	PE[15]	8%	11%	9%	10%	8%	11%	9%	10%
		—	PG[10]	8%	—	9%	—	8%	—	9%	—
	—	PG[11]	7%	11%	9%	9%	7%	11%	9%	9%	
	—	—	—	PH[11]	7%	10%	9%	9%	—	—	—
	—	—	—	PH[12]	7%	10%	8%	9%	—	—	—
	—	—	—	PI[5]	7%	—	8%	—	—	—	—
	—	—	—	PI[4]	7%	—	8%	—	—	—	—
	3	3	PC[3]	6%	—	8%	—	6%	—	8%	—
PC[2]			6%	8%	7%	7%	6%	8%	7%	7%	
PA[5]			6%	8%	7%	7%	6%	8%	7%	7%	
PA[6]			5%	—	6%	—	5%	—	6%	—	
PH[10]			5%	7%	6%	6%	5%	7%	6%	6%	
PC[1]			5%	19%	5%	13%	5%	19%	5%	13%	

Table 20. I/O weight<sup>1</sup> (continued)

Supply segment			Pad	176 LQFP				144/100 LQFP			
				Weight 5 V		Weight 3.3 V		Weight 5 V		Weight 3.3 V	
176 LQFP	144 LQFP	100 LQFP		SRC <sup>2</sup> = 0	SRC = 1	SRC = 0	SRC = 1	SRC = 0	SRC = 1	SRC = 0	SRC = 1
6	4	4	PC[0]	6%	9%	7%	8%	7%	10%	8%	8%
			PH[9]	7%	—	8%	—	7%	—	9%	—
			PE[2]	7%	10%	8%	9%	8%	11%	9%	10%
			PE[3]	7%	10%	9%	9%	8%	12%	10%	10%
			PC[5]	7%	11%	9%	9%	8%	12%	10%	11%
			PC[4]	8%	11%	9%	10%	9%	13%	10%	11%
			PE[4]	8%	11%	9%	10%	9%	13%	11%	12%
			PE[5]	8%	11%	10%	10%	9%	14%	11%	12%
		—	PH[4]	8%	12%	10%	10%	10%	14%	12%	12%
		—	PH[5]	8%	—	10%	—	10%	—	12%	—
		—	PH[6]	8%	12%	10%	11%	10%	15%	12%	13%
		—	PH[7]	9%	12%	10%	11%	11%	15%	13%	13%
	—	PH[8]	9%	12%	10%	11%	11%	16%	13%	14%	
	—	4	PE[6]	9%	12%	10%	11%	11%	16%	13%	14%
	—	—	PE[7]	9%	12%	10%	11%	11%	16%	14%	14%
	—	—	PI[3]	9%	—	10%	—	—	—	—	—
	—	—	PI[2]	9%	—	10%	—	—	—	—	—
	—	—	PI[1]	9%	—	10%	—	—	—	—	—
	—	—	PI[0]	9%	—	10%	—	—	—	—	—
	—	4	4	PC[12]	8%	12%	10%	11%	12%	18%	15%
—	—	—	PC[13]	8%	—	10%	—	13%	—	15%	—
—	—	—	PC[8]	8%	—	10%	—	13%	—	15%	—
—	—	—	PB[2]	8%	11%	9%	10%	13%	18%	15%	16%

<sup>1</sup> V<sub>DD</sub> = 3.3 V ± 10% / 5.0 V ± 10%, T<sub>A</sub> = -40 to 125 °C, unless otherwise specified

<sup>2</sup> SRC is the Slew Rate Control bit in SIU\_PCRx

### 3.7 $\overline{\text{RESET}}$ electrical characteristics

The device implements a dedicated bidirectional  $\overline{\text{RESET}}$  pin.

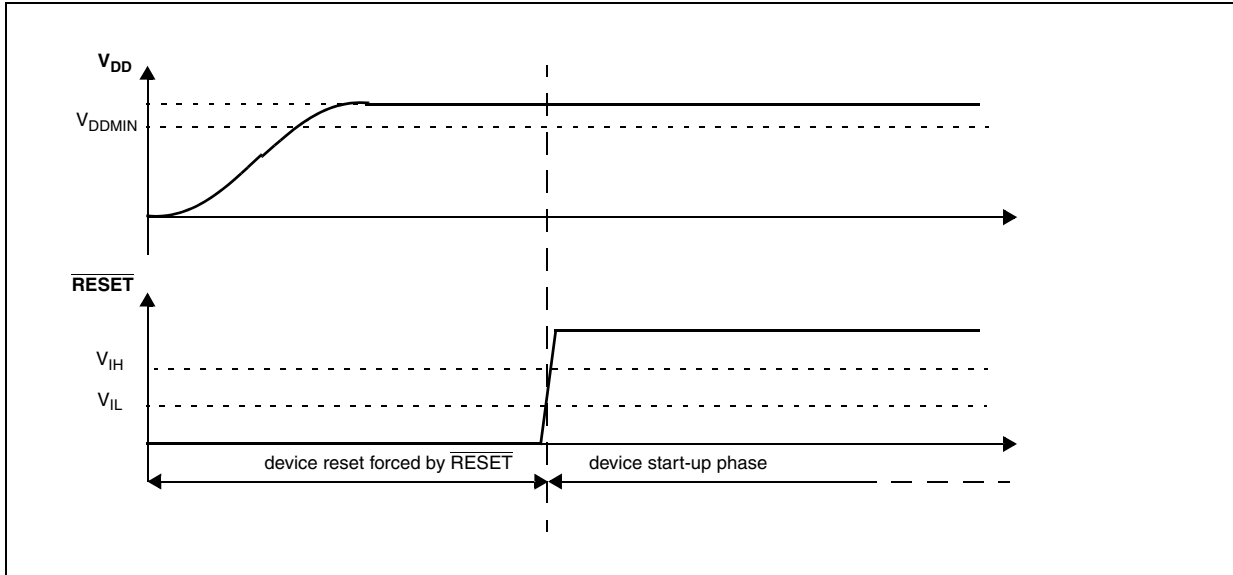

Figure 6. Start-up reset requirements

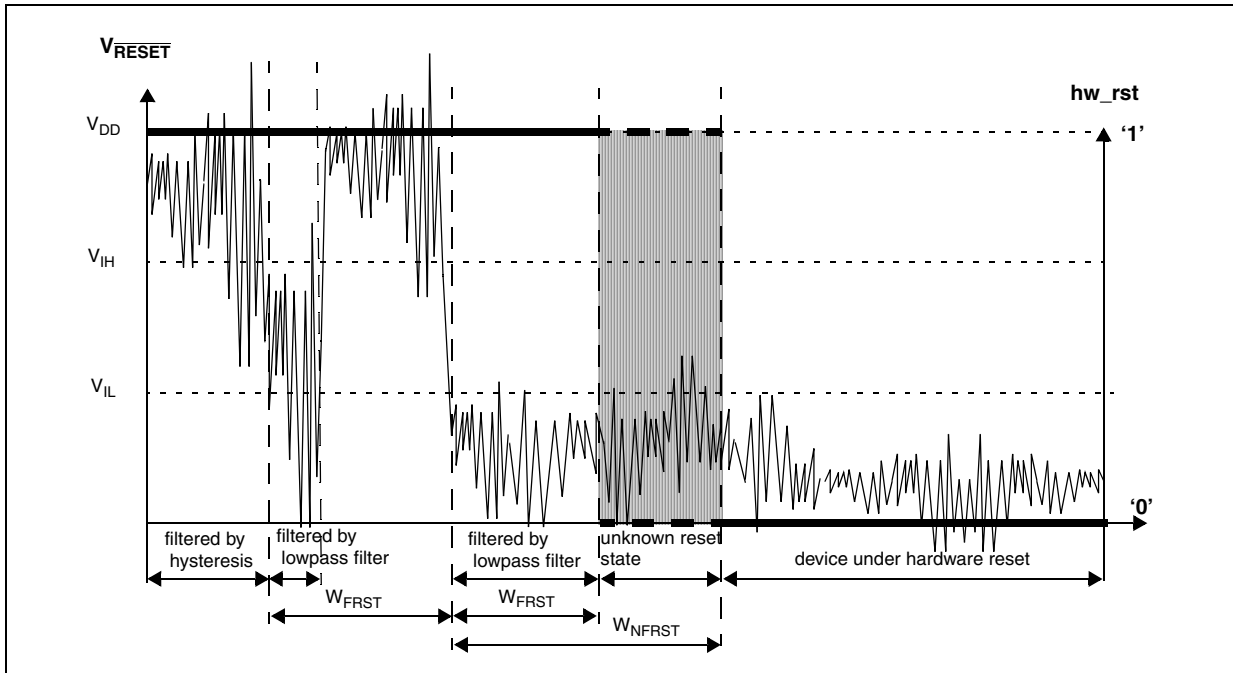

Figure 7. Noise filtering on reset signal

Table 21. Reset electrical characteristics

Symbol	C	Parameter	Conditions <sup>1</sup>	Value			Unit
				Min	Typ	Max	
V <sub>IH</sub>	SR P	Input High Level CMOS (Schmitt Trigger)	—	0.65V <sub>DD</sub>	—	V <sub>DD</sub> + 0.4	V

**Table 21. Reset electrical characteristics (continued)**

Symbol	C	Parameter	Conditions <sup>1</sup>	Value			Unit	
				Min	Typ	Max		
V <sub>IL</sub>	SR	P	Input low Level CMOS (Schmitt Trigger)	—	—	0.35V <sub>DD</sub>	V	
V <sub>HYS</sub>	CC	C	Input hysteresis CMOS (Schmitt Trigger)	—	—	0.1V <sub>DD</sub>	V	
V <sub>OL</sub>	CC	P	Output low level	Push Pull, I <sub>OL</sub> = 2 mA, V <sub>DD</sub> = 5.0 V ± 10%, PAD3V5V = 0 (recommended)	—	—	0.1V <sub>DD</sub>	V
				Push Pull, I <sub>OL</sub> = 1 mA, V <sub>DD</sub> = 5.0 V ± 10%, PAD3V5V = 1 <sup>2</sup>	—	—	0.1V <sub>DD</sub>	
				Push Pull, I <sub>OL</sub> = 1 mA, V <sub>DD</sub> = 3.3 V ± 10%, PAD3V5V = 1 (recommended)	—	—	0.5	
T <sub>tr</sub>	CC	D	Output transition time output pin <sup>3</sup> MEDIUM configuration	C <sub>L</sub> = 25 pF, V <sub>DD</sub> = 5.0 V ± 10%, PAD3V5V = 0	—	—	10	ns
				C <sub>L</sub> = 50 pF, V <sub>DD</sub> = 5.0 V ± 10%, PAD3V5V = 0	—	—	20	
				C <sub>L</sub> = 100 pF, V <sub>DD</sub> = 5.0 V ± 10%, PAD3V5V = 0	—	—	40	
				C <sub>L</sub> = 25 pF, V <sub>DD</sub> = 3.3 V ± 10%, PAD3V5V = 1	—	—	12	
				C <sub>L</sub> = 50 pF, V <sub>DD</sub> = 3.3 V ± 10%, PAD3V5V = 1	—	—	25	
				C <sub>L</sub> = 100 pF, V <sub>DD</sub> = 3.3 V ± 10%, PAD3V5V = 1	—	—	40	
W <sub>FRST</sub>	SR	P	$\overline{\text{RESET}}$ input filtered pulse	—	—	40	ns	
W <sub>NFRST</sub>	SR	P	$\overline{\text{RESET}}$ input not filtered pulse	—	1000	—	ns	
I <sub>WPU</sub>	CC	P	Weak pull-up current absolute value	V <sub>DD</sub> = 3.3 V ± 10%, PAD3V5V = 1	10	—	150	μA
				V <sub>DD</sub> = 5.0 V ± 10%, PAD3V5V = 0	10	—	150	
				V <sub>DD</sub> = 5.0 V ± 10%, PAD3V5V = 1 <sup>4</sup>	10	—	250	

<sup>1</sup> V<sub>DD</sub> = 3.3 V ± 10% / 5.0 V ± 10%, T<sub>A</sub> = -40 to 125 °C, unless otherwise specified

<sup>2</sup> This is a transient configuration during power-up, up to the end of reset PHASE2 (refer to the MC\_RGM chapter of the MPC5606BK Microcontroller Reference Manual).

<sup>3</sup> C<sub>L</sub> includes device and package capacitance (C<sub>PKG</sub> < 5 pF).

<sup>4</sup> The configuration PAD3V5 = 1 when V<sub>DD</sub> = 5 V is only transient configuration during power-up. All pads but RESET are configured in input or in high impedance state.

## 3.8 Power management electrical characteristics

### 3.8.1 Voltage regulator electrical characteristics

The device implements an internal voltage regulator to generate the low voltage core supply  $V_{DD\_LV}$  from the high voltage ballast supply  $V_{DD\_BV}$ . The regulator itself is supplied by the common I/O supply  $V_{DD}$ . The following supplies are involved:

- HV: High voltage external power supply for voltage regulator module. This must be provided externally through  $V_{DD}$  power pin.
- BV: High voltage external power supply for internal ballast module. This must be provided externally through  $V_{DD\_BV}$  power pin. Voltage values should be aligned with  $V_{DD}$ .
- LV: Low voltage internal power supply for core, FMPLL and Flash digital logic. This is generated by the internal voltage regulator but provided outside to connect stability capacitor. It is further split into four main domains to ensure noise isolation between critical LV modules within the device:
  - LV\_COR: Low voltage supply for the core. It is also used to provide supply for FMPLL through double bonding.
  - LV\_CFLA: Low voltage supply for code Flash module. It is supplied with dedicated ballast and shorted to LV\_COR through double bonding.
  - LV\_DFLA: Low voltage supply for data Flash module. It is supplied with dedicated ballast and shorted to LV\_COR through double bonding.
  - LV\_PLL: Low voltage supply for FMPLL. It is shorted to LV\_COR through double bonding.

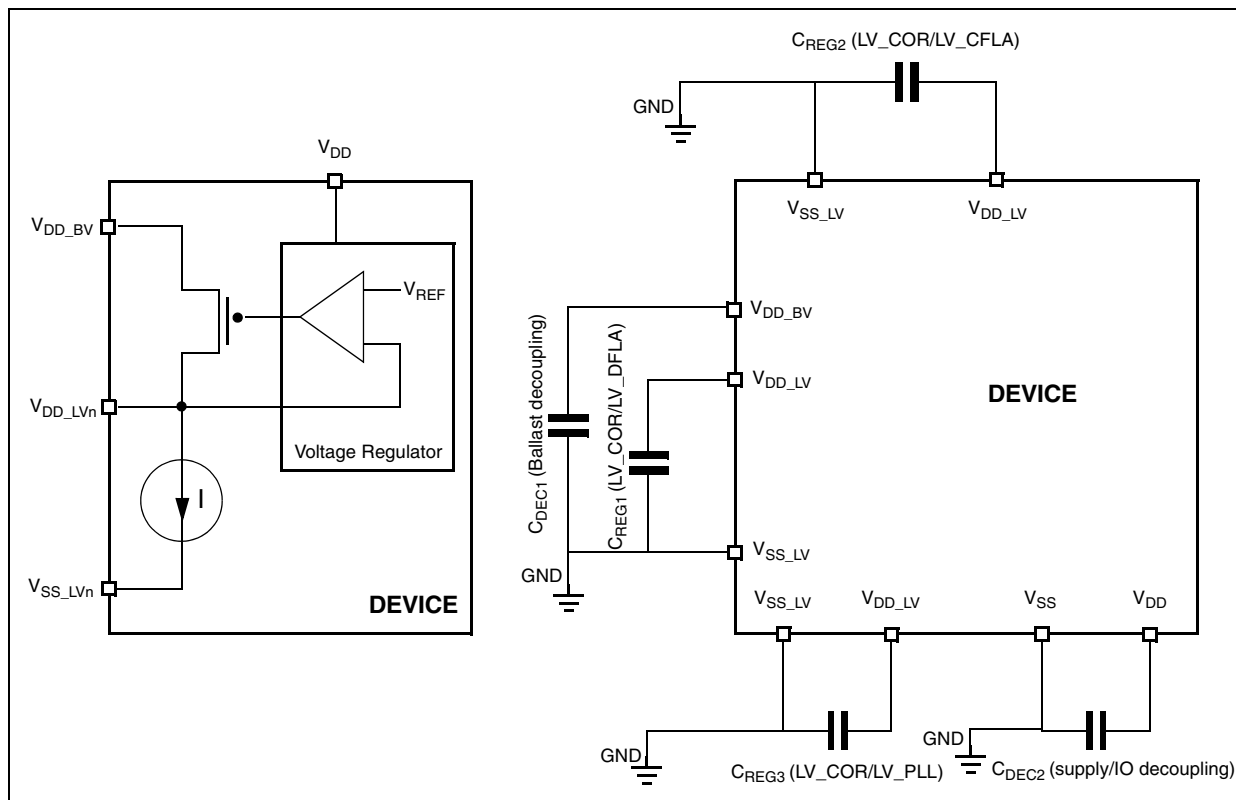
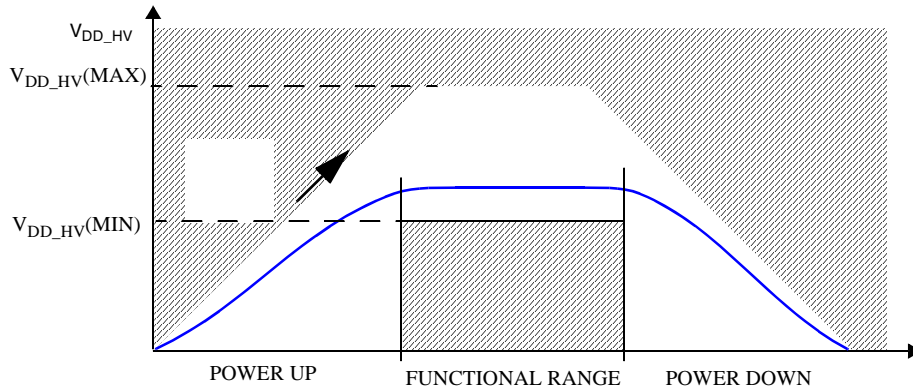

Figure 8. Voltage regulator capacitance connection

The internal voltage regulator requires external capacitance ( $C_{REGn}$ ) to be connected to the device in order to provide a stable low voltage digital supply to the device. Capacitances should be placed on the board as near as possible to the associated pins. Care should also be taken to limit the serial inductance of the board to less than 5 nH.

Each decoupling capacitor must be placed between each of the three  $V_{DD\_LV}/V_{SS\_LV}$  supply pairs to ensure stable voltage (see [Section 3.4, Recommended operating conditions](#)).

The internal voltage regulator requires controlled slew rate of  $V_{DD}/V_{DD\_BV}$  as described in [Figure 9](#).



**Figure 9.  $V_{DD}$  and  $V_{DD\_BV}$  maximum slope**

When STANDBY mode is used, further constraints apply to the  $V_{DD}/V_{DD\_BV}$  in order to guarantee correct regulator functionality during STANDBY exit. This is described in [Figure 10](#).

STANDBY regulator constraints should normally be guaranteed by implementing equivalent of  $C_{STDBY}$  capacitance on application board (capacitance and ESR typical values), but would actually depend on the exact characteristics of the application's external regulator.

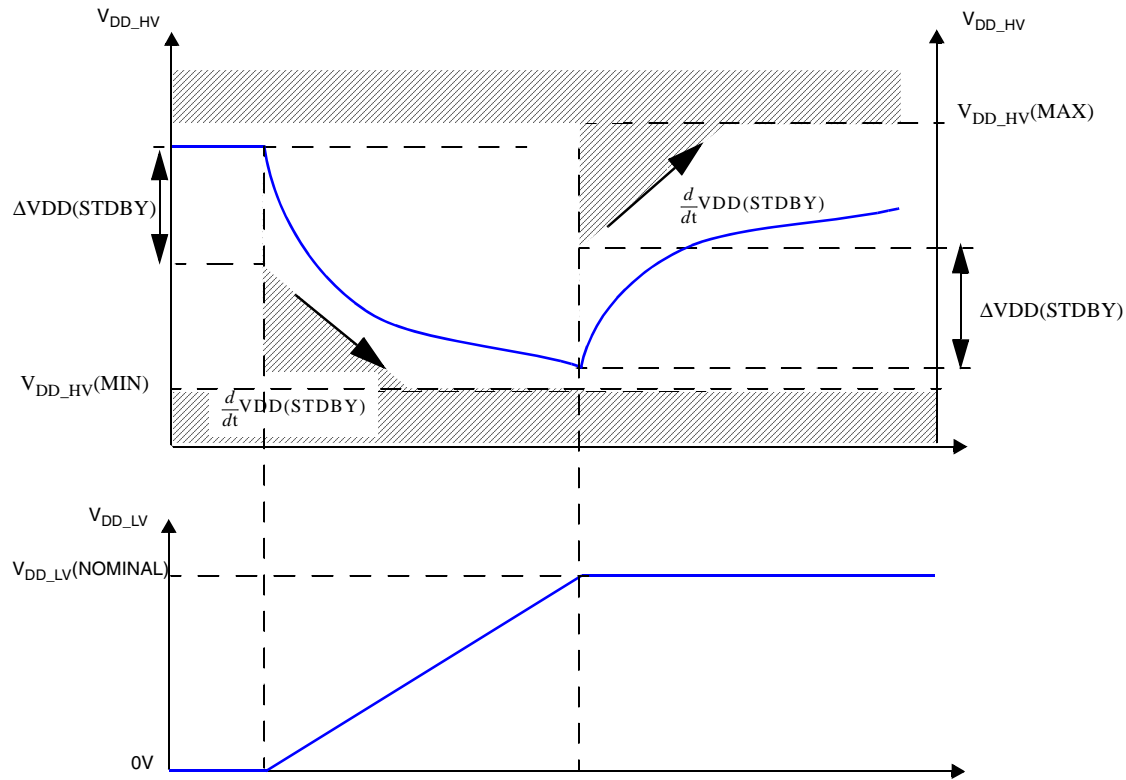

Figure 10.  $V_{DD}$  and  $V_{DD\_BV}$  supply constraints during STANDBY mode exit

Table 22. Voltage regulator electrical characteristics

Symbol	C	Parameter	Conditions <sup>1</sup>	Value			Unit	
				Min	Typ	Max		
$C_{REGn}$	SR	Internal voltage regulator external capacitance	—	200	—	500	nF	
$R_{REG}$	SR	Stability capacitor equivalent serial resistance	—	—	—	0.2	$\Omega$	
$C_{DEC1}$	SR	Decoupling capacitance <sup>2</sup> ballast	$V_{DD\_BV}/V_{SS\_LV}$ pair: $V_{DD\_BV} = 4.5\text{ V to }5.5\text{ V}$	$100^3$	$470^4$	—	nF	
			$V_{DD\_BV}/V_{SS\_LV}$ pair: $V_{DD\_BV} = 3\text{ V to }3.6\text{ V}$	400	—	—		
$C_{DEC2}$	SR	Decoupling capacitance regulator supply	$V_{DD}/V_{SS}$ pair	10	100	—	nF	
$V_{MREG}$	CC	P	Main regulator output voltage	Before exiting from reset	—	1.32	—	V
			After trimming	1.15	1.28	1.32		
$I_{MREG}$	SR	Main regulator current provided to $V_{DD\_LV}$ domain	—	—	—	150	mA	

**Table 22. Voltage regulator electrical characteristics (continued)**

Symbol	C	Parameter	Conditions <sup>1</sup>	Value			Unit	
				Min	Typ	Max		
I <sub>MREGINT</sub>	CC	D	Main regulator module current consumption	I <sub>MREG</sub> = 200 mA	—	—	2	mA
				I <sub>MREG</sub> = 0 mA	—	—	1	
V <sub>LPREG</sub>	CC	P	Low power regulator output voltage	After trimming	1.15	1.23	1.32	V
I <sub>LPREG</sub>	SR	—	Low power regulator current provided to V <sub>DD_LV</sub> domain	—	—	—	15	mA
I <sub>LPREGINT</sub>	CC	D	Low power regulator module current consumption	I <sub>LPREG</sub> = 15 mA; T <sub>A</sub> = 55 °C	—	—	600	μA
				I <sub>LPREG</sub> = 0 mA; T <sub>A</sub> = 55 °C	—	5	—	
V <sub>ULPREG</sub>	CC	P	Ultra low power regulator output voltage	After trimming	1.15	1.23	1.32	V
I <sub>ULPREG</sub>	SR	—	Ultra low power regulator current provided to V <sub>DD_LV</sub> domain	—	—	—	5	mA
I <sub>ULPREGINT</sub>	CC	D	Ultra low power regulator module current consumption	I <sub>ULPREG</sub> = 5 mA; T <sub>A</sub> = 55 °C	—	—	100	μA
				I <sub>ULPREG</sub> = 0 mA; T <sub>A</sub> = 55 °C	—	2	—	
I <sub>DD_BV</sub>	CC	D	Inrush average current on V <sub>DD_BV</sub> during power-up <sup>5</sup>	—	—	—	300 <sup>6</sup>	mA
$\left  \frac{d}{dt} V_{DD} \right $	SR	—	Maximum slope on VDD	—	—	—	250	mV/μs
ΔV <sub>VDD(STDBY)</sub>	SR	—	Maximum instant variation on VDD during STANDBY exit	—	—	—	30	mV
$\left  \frac{d}{dt} V_{DD}(STDBY) \right $	SR	—	Maximum slope on VDD during STANDBY exit	—	—	—	15	mV/μs

<sup>1</sup> V<sub>DD</sub> = 3.3 V ± 10% / 5.0 V ± 10%, T<sub>A</sub> = -40 to 125 °C, unless otherwise specified

<sup>2</sup> This capacitance value is driven by the constraints of the external voltage regulator supplying the V<sub>DD\_BV</sub> voltage. A typical value is in the range of 470 nF.

<sup>3</sup> This value is acceptable to guarantee operation from 4.5 V to 5.5 V

<sup>4</sup> External regulator and capacitance circuitry must be capable of providing I<sub>DD\_BV</sub> while maintaining supply V<sub>DD\_BV</sub> in operating range.

<sup>5</sup> Inrush current is seen only for short time during power-up and on standby exit (max 20 μs, depending on external capacitances to be load).

<sup>6</sup> The duration of the inrush current depends on the capacitance placed on LV pins. BV decoupling capacitors must be sized accordingly. Refer to I<sub>MREG</sub> value for minimum amount of current to be provided in cc.

### 3.8.2 Voltage monitor electrical characteristics

The device implements a Power-on Reset module to ensure correct power-up initialization, as well as four low voltage detectors to monitor the V<sub>DD</sub> and the V<sub>DD\_LV</sub> voltage while device is supplied:

- POR monitors  $V_{DD}$  during the power-up phase to ensure device is maintained in a safe reset state
- LVDHV3 monitors  $V_{DD}$  to ensure device reset below minimum functional supply
- LVDHV3B monitors  $V_{DD\_BV}$  to ensure device reset below minimum functional supply
- LVDHV5 monitors  $V_{DD}$  when application uses device in the  $5.0\text{ V} \pm 10\%$  range
- LVDLVCOR monitors power domain No. 1
- LVDLVBKP monitors power domain No. 0

### NOTE

When enabled, power domain No. 2 is monitored through LVDLVBKP.

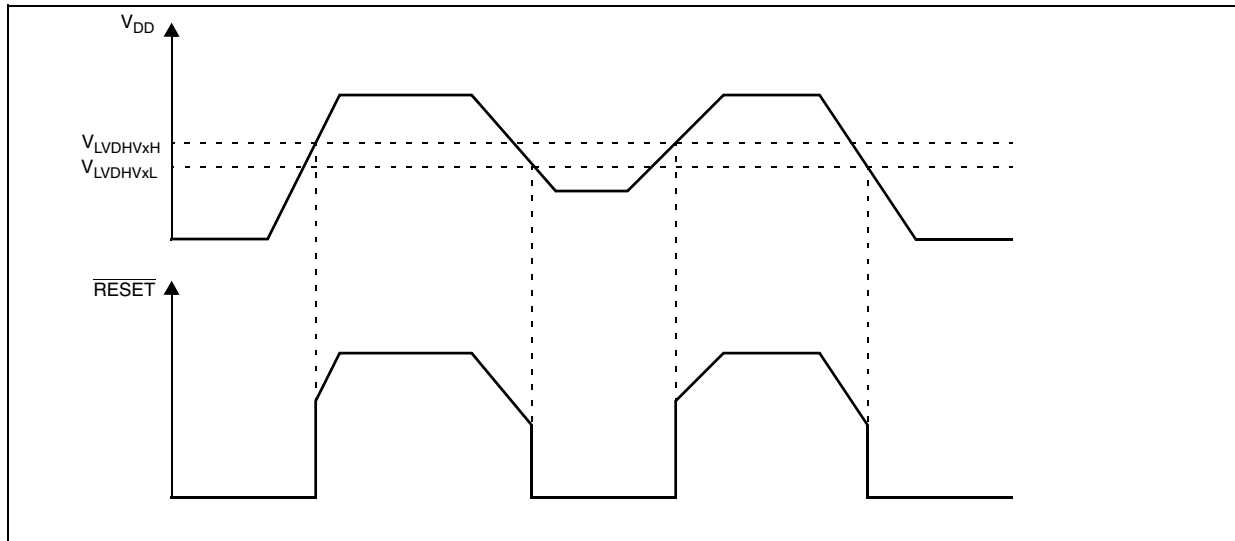

Figure 11. Low voltage monitor vs. reset

Table 23. Low voltage monitor electrical characteristics

Symbol	C	Parameter	Conditions <sup>1</sup>	Value			Unit
				Min	Typ	Max	
$V_{PORUP}$	SR	D	$T_A = 25\text{ }^\circ\text{C}$ , after trimming	1.0	—	5.5	V
$V_{PORH}$	CC	P		1.5	—	2.6	
$V_{LVDHV3H}$	CC	T		—	—	2.95	
$V_{LVDHV3L}$	CC	P		2.6	—	2.9	
$V_{LVDHV3BH}$	CC	T		—	—	2.95	
$V_{LVDHV3BL}$	CC	P		2.6	—	2.9	
$V_{LVDHV5H}$	CC	T		—	—	4.5	
$V_{LVDHV5L}$	CC	P		3.8	—	4.4	
$V_{LVDLVCORL}$	CC	P		1.08	—	—	
$V_{LVDLVBKPL}$	CC	P		1.08	—	1.14	

<sup>1</sup>  $V_{DD} = 3.3\text{ V} \pm 10\% / 5.0\text{ V} \pm 10\%$ ,  $T_A = -40$  to  $125\text{ }^\circ\text{C}$ , unless otherwise specified

### 3.9 Power consumption in different application modes

Table 24 provides DC electrical characteristics for significant application modes. These values are indicative values; actual consumption depends on the application.

**Table 24. Electrical characteristics in different application modes<sup>1</sup>**

Symbol	C	Parameter	Conditions <sup>2</sup>	Value			Unit		
				Min	Typ	Max			
$I_{DDMAX}^3$	CC	C	RUN mode maximum average current	—	81	130 <sup>4</sup>	mA		
$I_{DDRUN}^5$	CC	T	RUN mode typical average current <sup>6</sup>	$f_{CPU} = 8 \text{ MHz}$	—	12	—	mA	
		T		$f_{CPU} = 16 \text{ MHz}$	—	27	—		
		C		$f_{CPU} = 32 \text{ MHz}$	—	40	—		
		P		$f_{CPU} = 48 \text{ MHz}$	—	54	95		
		P		$f_{CPU} = 64 \text{ MHz}$	—	67	120		
$I_{DDHALT}$	CC	C	HALT mode current <sup>7</sup>	Slow internal RC oscillator (128 kHz) running	$T_A = 25 \text{ }^\circ\text{C}$	—	10	15	mA
		P		$T_A = 125 \text{ }^\circ\text{C}$	—	15	28		
$I_{DDSTOP}$	CC	P	STOP mode current <sup>8</sup>	Slow internal RC oscillator (128 kHz) running	$T_A = 25 \text{ }^\circ\text{C}$	—	130	500	$\mu\text{A}$
		D			$T_A = 55 \text{ }^\circ\text{C}$	—	180	—	
		D			$T_A = 85 \text{ }^\circ\text{C}$	—	1	5	mA
		D			$T_A = 105 \text{ }^\circ\text{C}$	—	3	9	
		P			$T_A = 125 \text{ }^\circ\text{C}$	—	5	14	
$I_{DDSTDBY2}$	CC	P	STANDBY2 mode current <sup>9</sup>	Slow internal RC oscillator (128 kHz) running	$T_A = 25 \text{ }^\circ\text{C}$	—	17	80	$\mu\text{A}$
		C			$T_A = 55 \text{ }^\circ\text{C}$	—	30	—	
		C			$T_A = 85 \text{ }^\circ\text{C}$	—	110	—	
		C			$T_A = 105 \text{ }^\circ\text{C}$	—	280	950	
		C			$T_A = 125 \text{ }^\circ\text{C}$	—	460	1700	
$I_{DDSTDBY1}$	CC	C	STANDBY1 mode current <sup>10</sup>	Slow internal RC oscillator (128 kHz) running	$T_A = 25 \text{ }^\circ\text{C}$	—	12	50	$\mu\text{A}$
		C			$T_A = 55 \text{ }^\circ\text{C}$	—	24	—	
		C			$T_A = 85 \text{ }^\circ\text{C}$	—	48	—	
		C			$T_A = 105 \text{ }^\circ\text{C}$	—	150	500	
		C			$T_A = 125 \text{ }^\circ\text{C}$	—	260	—	

<sup>1</sup> Except for  $I_{DDMAX}$ , all consumptions in this table apply to  $V_{DD\_BV}$  only and do not include  $V_{DD\_HV}$ .

<sup>2</sup>  $V_{DD} = 3.3 \text{ V} \pm 10\% / 5.0 \text{ V} \pm 10\%$ ,  $T_A = -40 \text{ to } 125 \text{ }^\circ\text{C}$ , unless otherwise specified

<sup>3</sup> Running consumption is given on voltage regulator supply ( $V_{DDREG}$ ).  $I_{DDMAX}$  is composed of three components:  $I_{DDMAX} = I_{DD}(V_{DD\_BV}) + I_{DD}(V_{DD\_HV}) + I_{DD}(V_{DD\_HV\_ADC})$ . It does not include a fourth component linked to I/Os toggling which is **highly** dependent on the application. The given value is thought to be a **worst case value** (64 MHz at 125 °C) with all peripherals running, and code fetched from code flash while modify operation on-going on data flash. Note that this value can be significantly reduced by the application: switch off unused peripherals (default), reduce peripheral frequency through internal prescaler, fetch from RAM most used functions, use low power mode when possible.

- <sup>4</sup> Higher current may be sunk by device during power-up and standby exit. Please refer to inrush current in [Table 22](#).
- <sup>5</sup> RUN current measured with typical application with accesses on both Flash and RAM.
- <sup>6</sup> Only for the “P” classification: Data and Code Flash in Normal Power. Code fetched from RAM: Serial IPs CAN and LIN in loop back mode, DSPI as Master, PLL as system clock (4 x Multiplier) peripherals on (eMIOS/CTU/ADC) and running at max frequency, periodic SW/WDG timer reset enabled.
- <sup>7</sup> Data Flash Power Down. Code Flash in Low Power. SIRC 128 kHz and FIRC 16 MHz on. 10 MHz XTAL clock. FlexCAN: instances: 0, 1, 2 ON (clocked but not reception or transmission), instances: 4, 5, 6 clocks gated. LINFlex: instances: 0, 1, 2 ON (clocked but not reception or transmission), instance: 3 to 9 clocks gated. eMIOS: instance: 0 ON (16 channels on PA[0]–PA[11] and PC[12]–PC[15]) with PWM 20 kHz, instance: 1 clock gated. DSPI: instance: 0 (clocked but no communication), instance: 1 to 5 clocks gated. RTC/API ON. PIT ON. STM ON. ADC1 OFF. ADC0 ON but no conversion except two analog watchdogs.
- <sup>8</sup> Only for the “P” classification: No clock, FIRC 16 MHz off, SIRC 128 kHz on, PLL off, HPvreg off, ULPVreg/LPVreg on. All possible peripherals off and clock gated. Flash in power down mode.
- <sup>9</sup> Only for the “P” classification: ULPreg on, HP/LPVreg off, 32 KB RAM on, device configured for minimum consumption, all possible modules switched off.
- <sup>10</sup> ULPreg on, HP/LPVreg off, 8 KB RAM on, device configured for minimum consumption, all possible modules switched off.

## 3.10 Flash memory electrical characteristics

### 3.10.1 Program/erase characteristics

[Table 25](#) shows the program and erase characteristics.

**Table 25. Program and erase specifications**

Symbol	C	Parameter	Conditions	Value				Unit	
				Min	Typ <sup>1</sup>	Initial max <sup>2</sup>	Max <sup>3</sup>		
T <sub>dwprogram</sub>	CC	C	Double word (64 bits) program time <sup>4</sup>	Code Flash	—	18	50	500	μs
			Data Flash	—	22				
T <sub>16Kpperase</sub>			16 KB block preprogram and erase time	Code Flash	—	200	500	5000	ms
			Data Flash	—	300				
T <sub>32Kpperase</sub>			32 KB block preprogram and erase time	Code Flash	—	300	600	5000	ms
			Data Flash	—	400				
T <sub>32Kpperase</sub>			32 KB block preprogram and erase time for sector B0F4	Code Flash	—	600	1200	10000	ms
T <sub>128Kpperase</sub>			128 KB block preprogram and erase time	Code Flash	—	600	1300	7500	ms
			Data Flash	—	800				
T <sub>128Kpperase</sub>			128 KB block preprogram and erase time for sector B0F5	Code Flash	—	1200	2600	15000	ms
T <sub>eslat</sub>		D	Erase Suspend Latency	—	—	—	30	30	μs
T <sub>ESRT</sub>		C	Erase Suspend Request Rate	Code Flash	20	—	—	—	ms
			Data Flash	10	—	—	—		

- <sup>1</sup> Typical program and erase times assume nominal supply values and operation at 25 °C. All times are subject to change pending device characterization.
- <sup>2</sup> Initial factory condition: < 100 program/erase cycles, 25 °C, typical supply voltage.
- <sup>3</sup> The maximum program and erase times occur after the specified number of program/erase cycles. These maximum values are characterized but not guaranteed.
- <sup>4</sup> Actual hardware programming times. This does not include software overhead.

**Table 26. Flash module life**

Symbol		C	Parameter	Conditions	Value			Unit
					Min	Typ	Max	
P/E	CC	C	Number of program/erase cycles per block for 16 KB blocks over the operating temperature range (T <sub>J</sub> )	—	100000	—	—	cycles
P/E	CC	C	Number of program/erase cycles per block for 32 KB blocks over the operating temperature range (T <sub>J</sub> )	—	10000	100000	—	cycles
P/E	CC	C	Number of program/erase cycles per block for 128 KB blocks over the operating temperature range (T <sub>J</sub> )	—	1000	100000	—	cycles
Retention	CC	C	Minimum data retention at 85 °C average ambient temperature <sup>1</sup>	Blocks with 0–1,000 P/E cycles	20	—	—	years
				Blocks with 1,001–10,000 P/E cycles	10	—	—	years
				Blocks with 10,001–100,000 P/E cycles	5	—	—	years

<sup>1</sup> Ambient temperature averaged over duration of application, not to exceed recommended product operating temperature range.

ECC circuitry provides correction of single bit faults and is used to improve further automotive reliability results. Some units will experience single bit corrections throughout the life of the product with no impact to product reliability.

**Table 27. Flash read access timing**

Symbol		C	Parameter	Conditions <sup>1</sup>	Max	Unit
f <sub>READ</sub>	CC	P	Maximum frequency for Flash reading	2 wait states	64	MHz
		C		1 wait state	40	
		C		0 wait states	20	

<sup>1</sup> V<sub>DD</sub> = 3.3 V ± 10% / 5.0 V ± 10%, T<sub>A</sub> = –40 to 125 °C, unless otherwise specified.

### 3.10.2 Flash power supply DC characteristics

Table 28 shows the power supply DC characteristics on external supply.

**Table 28. Flash power supply DC electrical characteristics**

Symbol	Parameter	Conditions <sup>1</sup>	Value			Unit	
			Min	Typ	Max		
I <sub>CFREAD</sub>	Sum of the current consumption on V <sub>DDHV</sub> and V <sub>DDBV</sub> on read access	Flash module read f <sub>CPU</sub> = 64 MHz <sup>2</sup>	Code Flash	—	—	33	mA
I <sub>DFREAD</sub>			Data Flash	—	—	33	
I <sub>CFMOD</sub>	Sum of the current consumption on V <sub>DDHV</sub> and V <sub>DDBV</sub> on matrix modification (program/erase)	Program /Erase on-going while reading Flash registers f <sub>CPU</sub> = 64 MHz <sup>2</sup>	Code Flash	—	—	52	mA
I <sub>DFMOD</sub>			Data Flash	—	—	33	
I <sub>CFLPW</sub>	Sum of the current consumption on V <sub>DDHV</sub> and V <sub>DDBV</sub> during Flash low power mode	—	Code Flash	—	—	1.1	mA
I <sub>DFLPW</sub>			Data Flash	—	—	900	
I <sub>CFPWD</sub>	Sum of the current consumption on V <sub>DDHV</sub> and V <sub>DDBV</sub> during Flash power down mode	—	Code Flash	—	—	150	μA
I <sub>DFPWD</sub>			Data Flash	—	—	150	

<sup>1</sup> V<sub>DD</sub> = 3.3 V ± 10% / 5.0 V ± 10%, T<sub>A</sub> = -40 to 125 °C, unless otherwise specified.

<sup>2</sup> f<sub>CPU</sub> 64 MHz can be achieved at up to 125 °C.

### 3.10.3 Start-up/Switch-off timings

**Table 29. Start-up time/Switch-off time**

Symbol	C	Parameter	Conditions <sup>1</sup>	Value			Unit
				Min	Typ	Max	
T <sub>FLARSTEXIT</sub>	CC	T	Delay for Flash module to exit reset mode	—	—	125	μs
T <sub>FLALPEXIT</sub>	CC	T	Delay for Flash module to exit low-power mode	—	—	0.5	
T <sub>FLAPDEXIT</sub>	CC	T	Delay for Flash module to exit power-down mode	—	—	30	
T <sub>FLALPENTRY</sub>	CC	T	Delay for Flash module to enter low-power mode	—	—	0.5	
T <sub>FLAPDENTRY</sub>	CC	T	Delay for Flash module to enter power-down mode	—	—	1.5	

<sup>1</sup> V<sub>DD</sub> = 3.3 V ± 10% / 5.0 V ± 10%, T<sub>A</sub> = -40 to 125 °C, unless otherwise specified.

## 3.11 Electromagnetic compatibility (EMC) characteristics

Susceptibility tests are performed on a sample basis during product characterization.

### 3.11.1 Designing hardened software to avoid noise problems

EMC characterization and optimization are performed at component level with a typical application environment and simplified MCU software. It should be noted that good EMC performance is highly dependent on the user application and the software in particular.

Therefore it is recommended that the user apply EMC software optimization and prequalification tests in relation with the EMC level requested for the application.

- Software recommendations – The software flowchart must include the management of runaway conditions such as:
  - Corrupted program counter
  - Unexpected reset
  - Critical data corruption (control registers...)
- Prequalification trials – Most of the common failures (unexpected reset and program counter corruption) can be reproduced by manually forcing a low state on the reset pin or the oscillator pins for 1 second.  
To complete these trials, ESD stress can be applied directly on the device. When unexpected behavior is detected, the software can be hardened to prevent unrecoverable errors occurring.

### 3.11.2 Electromagnetic interference (EMI)

The product is monitored in terms of emission based on a typical application. This emission test conforms to the IEC61967-1 standard, which specifies the general conditions for EMI measurements.

**Table 30. EMI radiated emission measurement<sup>1,2</sup>**

Symbol	C	Parameter	Conditions	Value			Unit		
				Min	Typ	Max			
—	SR	—	Scan range	—	—	1000	MHz		
f <sub>CPU</sub>	SR	—	Operating frequency	—	64	—	MHz		
V <sub>DD_LV</sub>	SR	—	LV operating voltages	—	1.28	—	V		
S <sub>EMI</sub>	CC	T	Peak level	V <sub>DD</sub> = 5 V, T <sub>A</sub> = 25 °C, LQFP144 package Test conforming to IEC 61967-2, f <sub>OSC</sub> = 8 MHz/f <sub>CPU</sub> = 64 MHz	No PLL frequency modulation	—	—	18	dBμV
				± 2% PLL frequency modulation	—	—	14	dBμV	

<sup>1</sup> EMI testing and I/O port waveforms per IEC 61967-1, -2, -4

<sup>2</sup> For information on conducted emission and susceptibility measurement (norm IEC 61967-4), please contact your local marketing representative.

### 3.11.3 Absolute maximum ratings (electrical sensitivity)

Based on two different tests (ESD and LU) using specific measurement methods, the product is stressed in order to determine its performance in terms of electrical sensitivity.

#### 3.11.3.1 Electrostatic discharge (ESD)

Electrostatic discharges (a positive then a negative pulse separated by 1 second) are applied to the pins of each sample according to each pin combination. The sample size depends on the number of supply pins in the device (3 parts×(n + 1) supply pin). This test conforms to the AEC-Q100-002/-003/-011 standard.

**Table 31. ESD absolute maximum ratings<sup>1,2</sup>**

Symbol	Ratings	Conditions	Class	Max value <sup>3</sup>	Unit
V <sub>ESD(HBM)</sub>	Electrostatic discharge voltage (Human Body Model)	T <sub>A</sub> = 25 °C conforming to AEC-Q100-002	H1C	2000	V
V <sub>ESD(MM)</sub>	Electrostatic discharge voltage (Machine Model)	T <sub>A</sub> = 25 °C conforming to AEC-Q100-003	M2	200	
V <sub>ESD(CDM)</sub>	Electrostatic discharge voltage (Charged Device Model)	T <sub>A</sub> = 25 °C conforming to AEC-Q100-011	C3A	500 750 (corners)	

<sup>1</sup> All ESD testing is in conformity with CDF-AEC-Q100 Stress Test Qualification for Automotive Grade Integrated Circuits.

<sup>2</sup> A device will be defined as a failure if after exposure to ESD pulses the device no longer meets the device specification requirements. Complete DC parametric and functional testing shall be performed per applicable device specification at room temperature followed by hot temperature, unless specified otherwise in the device specification.

<sup>3</sup> Data based on characterization results, not tested in production

### 3.11.3.2 Static latch-up (LU)

Two complementary static tests are required on six parts to assess the latch-up performance:

- A supply overvoltage is applied to each power supply pin.
- A current injection is applied to each input, output and configurable I/O pin.

These tests are compliant with the EIA/JESD 78 IC latch-up standard.

**Table 32. Latch-up results**

Symbol	Parameter	Conditions	Class
LU	Static latch-up class	T <sub>A</sub> = 125 °C conforming to JESD 78	II level A

## 3.12 Fast external crystal oscillator (4 to 16 MHz) electrical characteristics

The device provides an oscillator/resonator driver. [Figure 12](#) describes a simple model of the internal oscillator driver and provides an example of a connection for an oscillator or a resonator.

[Table 33](#) provides the parameter description of 4 MHz to 16 MHz crystals used for the design simulations.

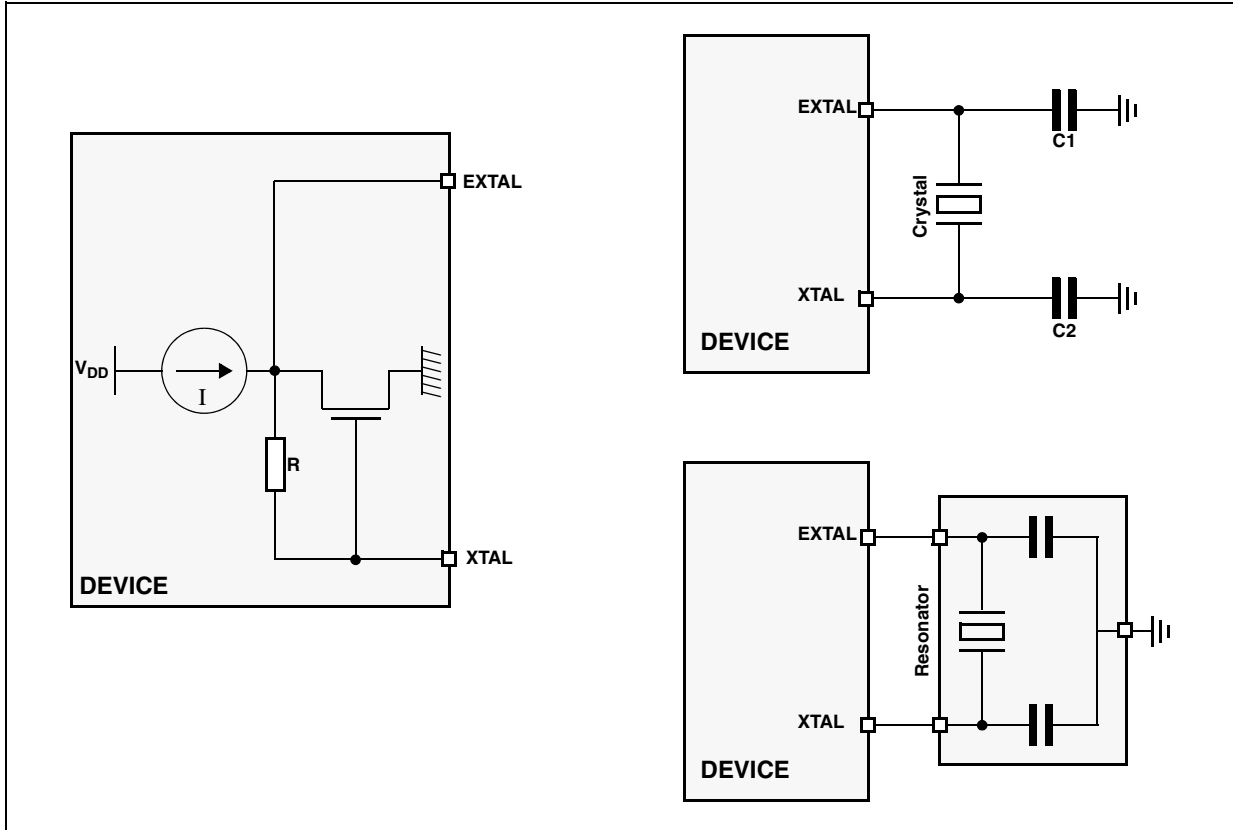

Figure 12. Crystal oscillator and resonator connection scheme

**NOTE**

XTAL/EXTAL must not be directly used to drive external circuits.

**Table 33. Crystal description**

Nominal frequency (MHz)	NDK crystal reference	Crystal equivalent series resistance ESR $\Omega$	Crystal motional capacitance ( $C_m$ ) fF	Crystal motional inductance ( $L_m$ ) mH	Load on xtalin/xtalout $C1 = C2$ (pF) <sup>1</sup>	Shunt capacitance between xtalout and xtal in $C0^2$ (pF)
4	NX8045GB	300	2.68	591.0	21	2.93
8	NX5032GA	300	2.46	160.7	17	3.01
10		150	2.93	86.6	15	2.91
12		120	3.11	56.5	15	2.93
16		120	3.90	25.3	10	3.00

<sup>1</sup> The values specified for C1 and C2 are the same as used in simulations. It should be ensured that the testing includes all the parasitics (from the board, probe, crystal, etc.) as the AC / transient behavior depends upon them.

<sup>2</sup> The value of C0 specified here includes 2 pF additional capacitance for parasitics (to be seen with bond-pads, package, etc.).

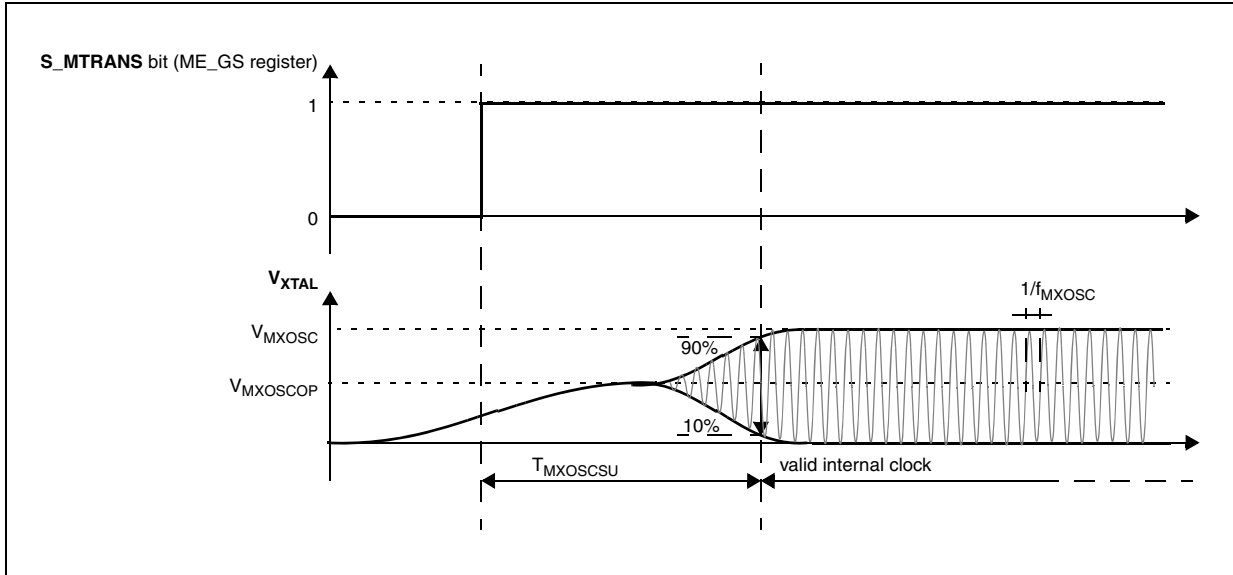

Figure 13. Fast external crystal oscillator (4 to 16 MHz) electrical characteristics

Table 34. Fast external crystal oscillator (4 to 16 MHz) electrical characteristics

Symbol	C	Parameter	Conditions <sup>1</sup>	Value			Unit	
				Min	Typ	Max		
$f_{FXOSC}$	SR	—	Fast external crystal oscillator frequency	—	—	—	MHz	
$g_{mFXOSC}$	CC	C	Fast external crystal oscillator transconductance	$V_{DD} = 3.3\text{ V} \pm 10\%$ , PAD3V5V = 1 OSCILLATOR_MARGIN = 0	2.2	—	8.2	mA/V
	CC	P		$V_{DD} = 5.0\text{ V} \pm 10\%$ , PAD3V5V = 0 OSCILLATOR_MARGIN = 0	2.0	—	7.4	
	CC	C		$V_{DD} = 3.3\text{ V} \pm 10\%$ , PAD3V5V = 1 OSCILLATOR_MARGIN = 1	2.7	—	9.7	
	CC	C		$V_{DD} = 5.0\text{ V} \pm 10\%$ , PAD3V5V = 0 OSCILLATOR_MARGIN = 1	2.5	—	9.2	
$V_{FXOSC}$	CC	T	Oscillation amplitude at EXTAL	$f_{OSC} = 4\text{ MHz}$ , OSCILLATOR_MARGIN = 0	1.3	—	—	V
				$f_{OSC} = 16\text{ MHz}$ , OSCILLATOR_MARGIN = 1	1.3	—	—	
$V_{FXOSCO}$	CC	P	Oscillation operating point	—	—	0.95	V	
$I_{FXOSC}^2$	CC	T	Fast external crystal oscillator consumption	—	—	2	3	mA

**Table 34. Fast external crystal oscillator (4 to 16 MHz) electrical characteristics (continued)**

Symbol	C	Parameter	Conditions <sup>1</sup>	Value			Unit
				Min	Typ	Max	
T <sub>FXOSCSU</sub>	CC	Fast external crystal oscillator start-up time	f <sub>OSC</sub> = 4 MHz, OSCILLATOR_MARGIN = 0	—	—	6	ms
			f <sub>OSC</sub> = 16 MHz, OSCILLATOR_MARGIN = 1	—	—	1.8	
V <sub>IH</sub>	SR	Input high level CMOS (Schmitt Trigger)	Oscillator bypass mode	0.65V <sub>DD</sub>	—	V <sub>DD</sub> + 0.4	V
V <sub>IL</sub>	SR	Input low level CMOS (Schmitt Trigger)	Oscillator bypass mode	-0.4	—	0.35V <sub>DD</sub>	V

<sup>1</sup> V<sub>DD</sub> = 3.3 V ± 10% / 5.0 V ± 10%, T<sub>A</sub> = -40 to 125 °C, unless otherwise specified

<sup>2</sup> Stated values take into account only analog module consumption but not the digital contributor (clock tree and enabled peripherals).

### 3.13 Slow external crystal oscillator (32 kHz) electrical characteristics

The device provides a low power oscillator/resonator driver.

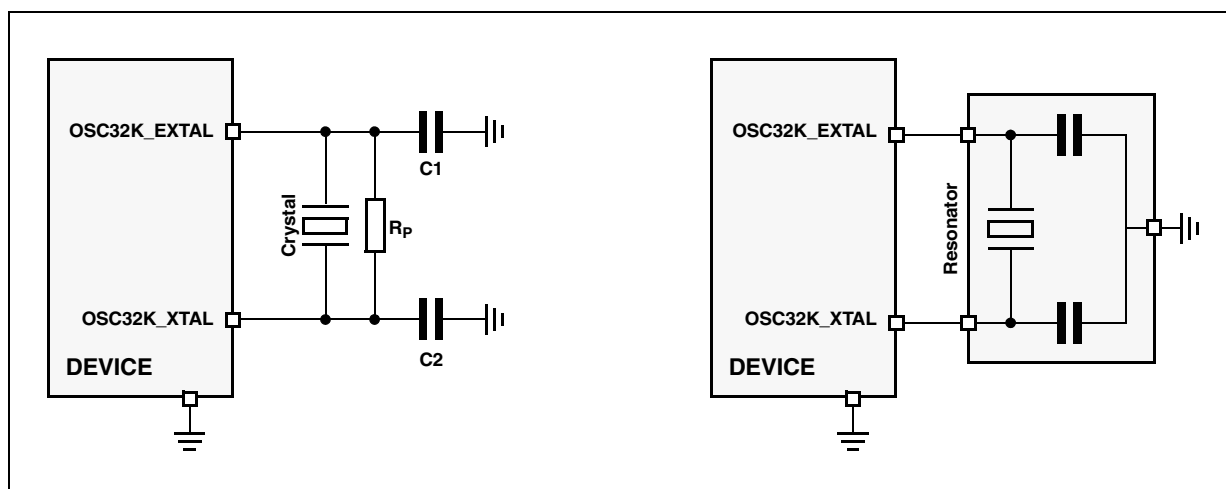

**Figure 14. Crystal oscillator and resonator connection scheme**

#### NOTE

OSC32K\_XTAL/OSC32K\_EXTAL must not be directly used to drive external circuits.

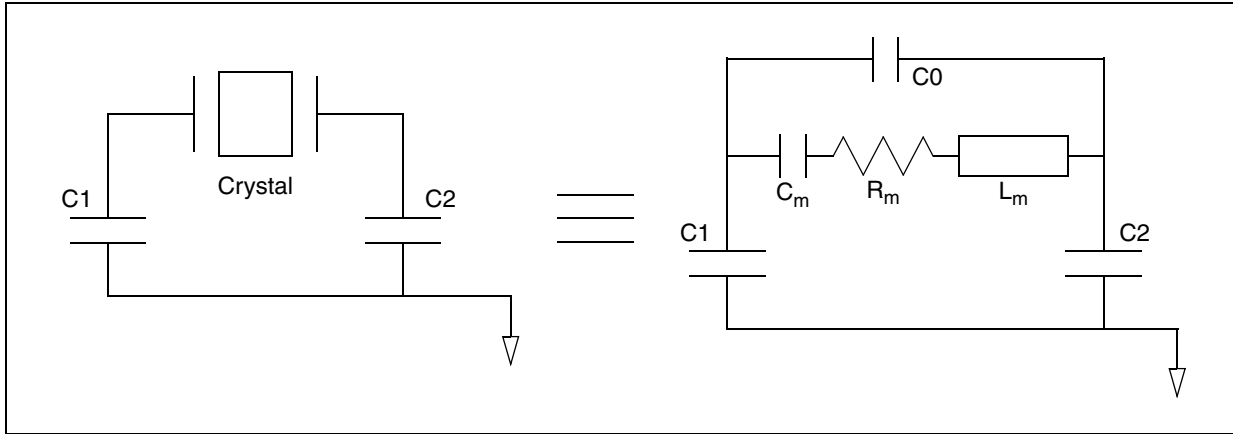

Figure 15. Equivalent circuit of a quartz crystal

Table 35. Crystal motional characteristics<sup>1</sup>

Symbol	Parameter	Conditions	Value			Unit
			Min	Typ	Max	
$L_m$	Motional inductance	—	—	11.796	—	KH
$C_m$	Motional capacitance	—	—	2	—	fF
C1/C2	Load capacitance at OSC32K_XTAL and OSC32K_EXTAL with respect to ground <sup>2</sup>	—	18	—	28	pF
$R_m^3$	Motional resistance	AC coupled at $C_0 = 2.85 \text{ pF}^4$	—	—	65	k $\Omega$
		AC coupled at $C_0 = 4.9 \text{ pF}^4$	—	—	50	
		AC coupled at $C_0 = 7.0 \text{ pF}^4$	—	—	35	
		AC coupled at $C_0 = 9.0 \text{ pF}^4$	—	—	30	

<sup>1</sup> The crystal used is Epson Toyocom MC306.

<sup>2</sup> This is the recommended range of load capacitance at OSC32K\_XTAL and OSC32K\_EXTAL with respect to ground. It includes all the parasitics due to board traces, crystal and package.

<sup>3</sup> Maximum ESR ( $R_m$ ) of the crystal is 50 k $\Omega$

<sup>4</sup>  $C_0$  Includes a parasitic capacitance of 2.0 pF between OSC32K\_XTAL and OSC32K\_EXTAL pins.

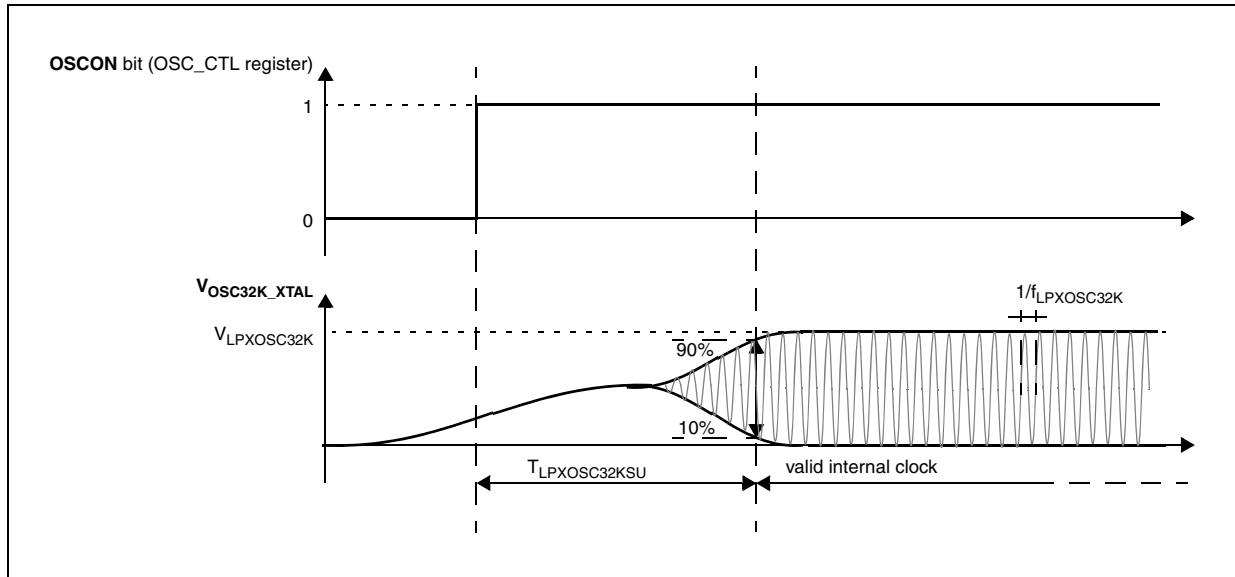

Figure 16. Slow external crystal oscillator (32 kHz) electrical characteristics

Table 36. Slow external crystal oscillator (32 kHz) electrical characteristics

Symbol	C	Parameter	Conditions <sup>1</sup>	Value			Unit
				Min	Typ	Max	
f <sub>SXOSC</sub>	SR	—	Slow external crystal oscillator frequency	32	32.768	40	kHz
V <sub>SXOSC</sub>	CC	T	Oscillation amplitude	—	2.1	—	V
I <sub>SXOSCBIAS</sub>	CC	T	Oscillation bias current	—	2.5		μA
I <sub>SXOSC</sub>	CC	T	Slow external crystal oscillator consumption	—	—	8	μA
T <sub>SXOSCSU</sub>	CC	T	Slow external crystal oscillator start-up time	—	—	2 <sup>2</sup>	s

<sup>1</sup> V<sub>DD</sub> = 3.3 V ± 10% / 5.0 V ± 10%, T<sub>A</sub> = -40 to 125 °C, unless otherwise specified

<sup>2</sup> Start-up time has been measured with EPSON TOYOCOM MC306 crystal. Variation may be seen with other crystal.

### 3.14 FMPLL electrical characteristics

The device provides a frequency modulated phase locked loop (FMPLL) module to generate a fast system clock from the FXOSC or FIRC sources.

Table 37. FMPLL electrical characteristics

Symbol	C	Parameter	Conditions <sup>1</sup>	Value			Unit
				Min	Typ	Max	
f <sub>PLLIN</sub>	SR	—	FMPLL reference clock <sup>2</sup>	4	—	64	MHz
Δ <sub>PLLIN</sub>	SR	—	FMPLL reference clock duty cycle <sup>2</sup>	40	—	60	%

**Table 37. FMPLL electrical characteristics (continued)**

Symbol	C	Parameter	Conditions <sup>1</sup>	Value			Unit	
				Min	Typ	Max		
f <sub>PLLOUT</sub>	CC	P	FMPLL output clock frequency	—	16	64	MHz	
f <sub>VCO</sub> <sup>3</sup>	CC	P	VCO frequency without frequency modulation	—	256	512	MHz	
		P	VCO frequency with frequency modulation	—	245.76	532.48		
f <sub>CPU</sub>	SR	—	System clock frequency	—	—	64 <sup>4</sup>	MHz	
f <sub>FREE</sub>	CC	P	Free-running frequency	—	20	150	MHz	
t <sub>LOCK</sub>	CC	P	FMPLL lock time	Stable oscillator (f <sub>PLLIN</sub> = 16 MHz)		40	100	μs
Δt <sub>STJIT</sub>	CC	—	FMPLL short term jitter <sup>5</sup>	f <sub>sys</sub> maximum	—4	4	%	
Δt <sub>LTJIT</sub>	CC	—	FMPLL long term jitter	f <sub>PLLCLK</sub> at 64 MHz, 4000 cycles		—	10	ns
I <sub>PLL</sub>	CC	C	FMPLL consumption	T <sub>A</sub> = 25 °C		—	4	mA

<sup>1</sup> V<sub>DD</sub> = 3.3 V ± 10% / 5.0 V ± 10%, T<sub>A</sub> = -40 to 125 °C, unless otherwise specified

<sup>2</sup> PLLIN clock retrieved directly from FXOSC clock. Input characteristics are granted when oscillator is used in functional mode. When bypass mode is used, oscillator input clock should verify f<sub>PLLIN</sub> and Δ<sub>PLLIN</sub>.

<sup>3</sup> Frequency modulation is considered ± 4%.

<sup>4</sup> f<sub>CPU</sub> 64 MHz can be achieved only at up to 105 °C.

<sup>5</sup> Short term jitter is measured on the clock rising edge at cycle *n* and *n* + 4.

### 3.15 Fast internal RC oscillator (16 MHz) electrical characteristics

The device provides a 16 MHz main internal RC oscillator. This is used as the default clock at the power-up of the device.

**Table 38. Fast internal RC oscillator (16 MHz) electrical characteristics**

Symbol	C	Parameter	Conditions <sup>1</sup>	Value			Unit		
				Min	Typ	Max			
f <sub>FIRC</sub>	CC	Fast internal RC oscillator high frequency	T <sub>A</sub> = 25 °C, trimmed	—	16	—	MHz		
	SR		—	12	20				
I <sub>FIRC RUN</sub> <sup>2</sup>	CC	T	Fast internal RC oscillator high frequency current in running mode	T <sub>A</sub> = 25 °C, trimmed		—	200	μA	
I <sub>FIRC PWD</sub>	CC	D	Fast internal RC oscillator high frequency current in power down mode	T <sub>A</sub> = 25 °C		—	10	μA	
I <sub>FIRC STOP</sub>	CC	T	Fast internal RC oscillator high frequency and system clock current in stop mode	T <sub>A</sub> = 25 °C	sysclk = off	—	500	—	μA
				sysclk = 2 MHz	—	600	—		
				sysclk = 4 MHz	—	700	—		
				sysclk = 8 MHz	—	900	—		
				sysclk = 16 MHz	—	1250	—		

**Table 38. Fast internal RC oscillator (16 MHz) electrical characteristics (continued)**

Symbol	C	Parameter	Conditions <sup>1</sup>	Value			Unit	
				Min	Typ	Max		
T <sub>FIRCSU</sub>	CC	C	Fast internal RC oscillator start-up time	V <sub>DD</sub> = 5.0 V ± 10%	—	1.1	2.0	µs
Δ <sub>FIRCPRE</sub>	CC	C	Fast internal RC oscillator precision after software trimming of f <sub>FIRC</sub>	T <sub>A</sub> = 25 °C	-1	—	1	%
Δ <sub>FIRCTRM</sub>	CC	C	Fast internal RC oscillator trimming step	T <sub>A</sub> = 25 °C	—	1.6	—	%
Δ <sub>FIRCVAR</sub>	CC	C	Fast internal RC oscillator variation over temperature and supply with respect to f <sub>FIRC</sub> at T <sub>A</sub> = 25 °C in high-frequency configuration	—	-5	—	5	%

<sup>1</sup> V<sub>DD</sub> = 3.3 V ± 10% / 5.0 V ± 10%, T<sub>A</sub> = -40 to 125 °C, unless otherwise specified

<sup>2</sup> This does not include consumption linked to clock tree toggling and peripherals consumption when RC oscillator is ON.

### 3.16 Slow internal RC oscillator (128 kHz) electrical characteristics

The device provides a 128 kHz low power internal RC oscillator. This can be used as the reference clock for the RTC module.

**Table 39. Slow internal RC oscillator (128 kHz) electrical characteristics**

Symbol	C	Parameter	Conditions <sup>1</sup>	Value			Unit	
				Min	Typ	Max		
f <sub>SIRC</sub>	CC	P	Slow internal RC oscillator low frequency	T <sub>A</sub> = 25 °C, trimmed	—	128	—	kHz
	SR			—	100	—	150	
I <sub>SIRC</sub> <sup>2</sup>	CC	C	Slow internal RC oscillator low frequency current	T <sub>A</sub> = 25 °C, trimmed	—	—	5	µA
T <sub>SIRCSU</sub>	CC	P	Slow internal RC oscillator start-up time	T <sub>A</sub> = 25 °C, V <sub>DD</sub> = 5.0 V ± 10%	—	8	12	µs
Δ <sub>SIRCPRE</sub>	CC	C	Slow internal RC oscillator precision after software trimming of f <sub>SIRC</sub>	T <sub>A</sub> = 25 °C	-2	—	2	%
Δ <sub>SIRCTRM</sub>	CC	C	Slow internal RC oscillator trimming step	—	—	2.7	—	%
Δ <sub>SIRCVAR</sub>	CC	C	Slow internal RC oscillator variation in temperature and supply with respect to f <sub>SIRC</sub> at T <sub>A</sub> = 55 °C in high frequency configuration	High frequency configuration	-10	—	10	%

<sup>1</sup> V<sub>DD</sub> = 3.3 V ± 10% / 5.0 V ± 10%, T<sub>A</sub> = -40 to 125 °C, unless otherwise specified

<sup>2</sup> This does not include consumption linked to clock tree toggling and peripherals consumption when RC oscillator is ON.

## 3.17 ADC electrical characteristics

### 3.17.1 Introduction

The device provides two Successive Approximation Register (SAR) analog-to-digital converters (10-bit and 12-bit).

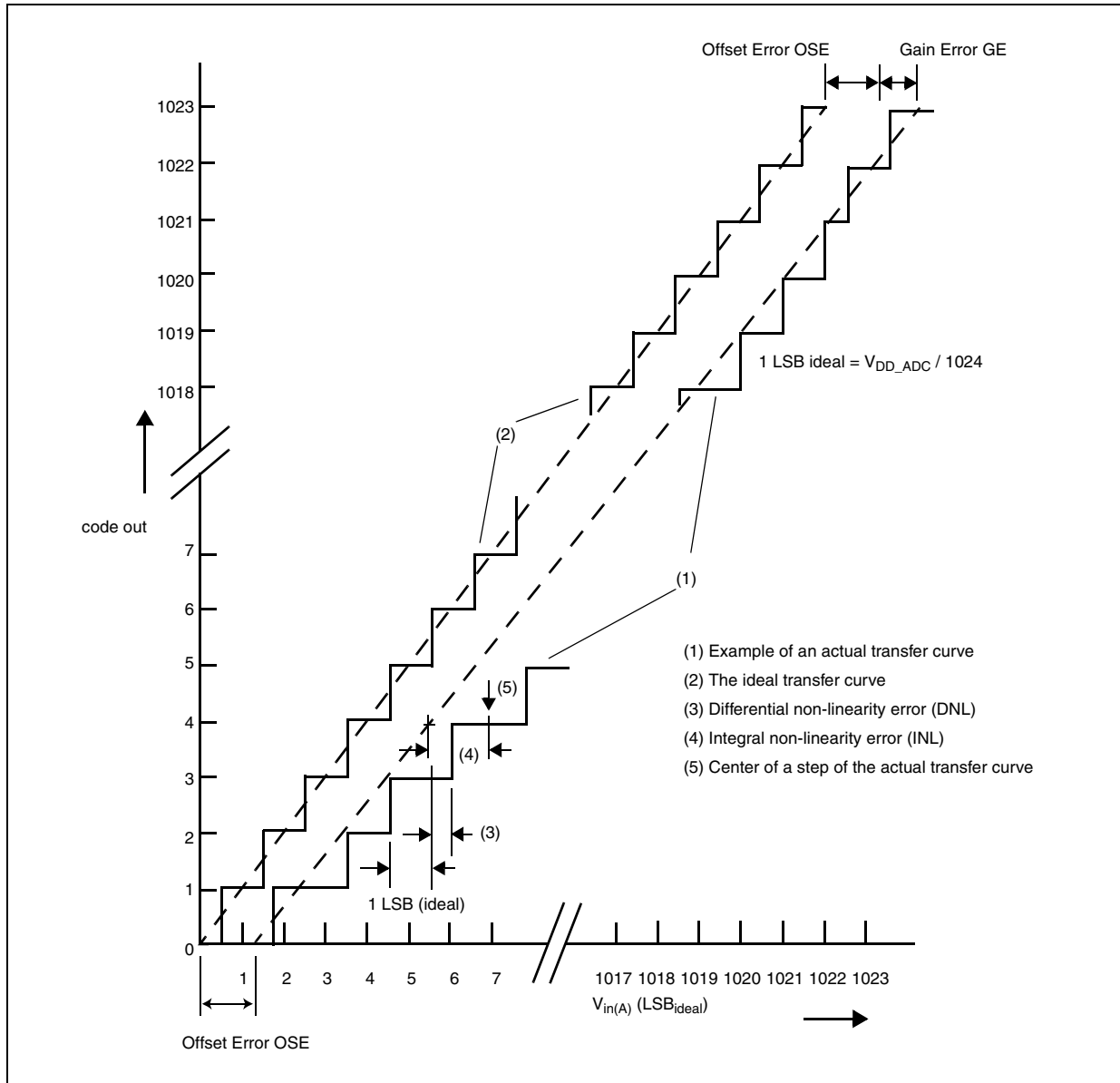

Figure 17. ADC\_0 characteristic and error definitions

### 3.17.2 Input impedance and ADC accuracy

In the following analysis, the input circuit corresponding to the precise channels is considered.

To preserve the accuracy of the A/D converter, it is necessary that analog input pins have low AC impedance. Placing a capacitor with good high frequency characteristics at the input pin of the device can be effective: the capacitor should be as large as

possible, ideally infinite. This capacitor contributes to attenuating the noise present on the input pin; furthermore, it sources charge during the sampling phase, when the analog signal source is a high-impedance source.

A real filter can typically be obtained by using a series resistance with a capacitor on the input pin (simple RC filter). The RC filtering may be limited according to the value of source impedance of the transducer or circuit supplying the analog signal to be measured. The filter at the input pins must be designed taking into account the dynamic characteristics of the input signal (bandwidth) and the equivalent input impedance of the ADC itself.

In fact a current sink contributor is represented by the charge sharing effects with the sampling capacitance:  $C_S$  being substantially a switched capacitance, with a frequency equal to the conversion rate of the ADC, it can be seen as a resistive path to ground. For instance, assuming a conversion rate of 1 MHz, with  $C_S$  equal to 3 pF, a resistance of 330 k $\Omega$  is obtained ( $R_{EQ} = 1 / (fc \times C_S)$ , where  $fc$  represents the conversion rate at the considered channel). To minimize the error induced by the voltage partitioning between this resistance (sampled voltage on  $C_S$ ) and the sum of  $R_S + R_F + R_L + R_{SW} + R_{AD}$ , the external circuit must be designed to respect the [Equation 4](#):

**Eqn. 4**

$$V_A \cdot \frac{R_S + R_F + R_L + R_{SW} + R_{AD}}{R_{EQ}} < \frac{1}{2} \text{LSB}$$

[Equation 4](#) generates a constraint for external network design, in particular on resistive path. Internal switch resistances ( $R_{SW}$  and  $R_{AD}$ ) can be neglected with respect to external resistances.

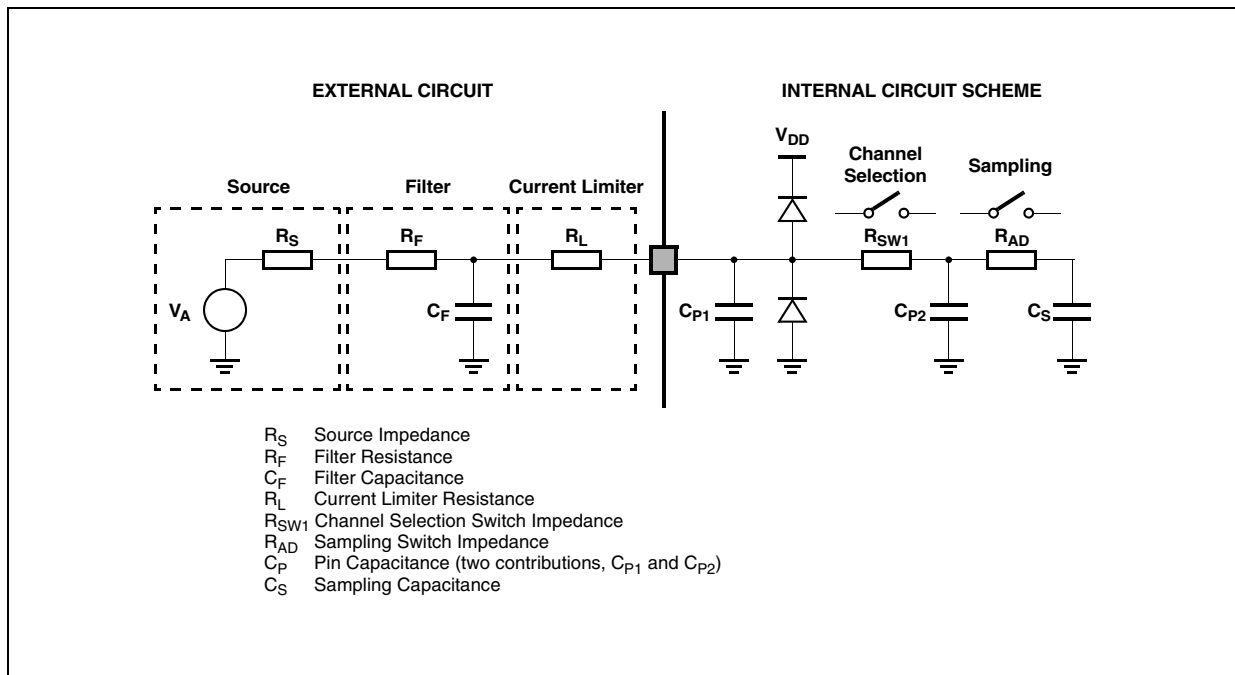

**Figure 18. Input equivalent circuit (precise channels)**

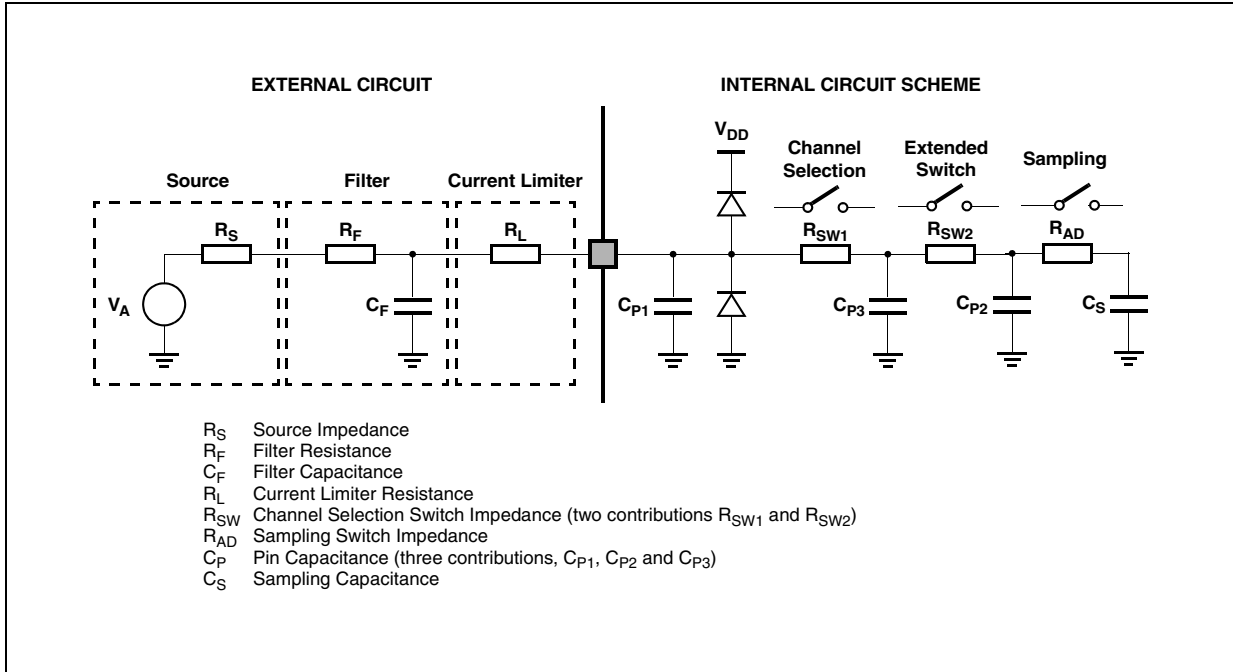

Figure 19. Input equivalent circuit (extended channels)

A second aspect involving the capacitance network shall be considered. Assuming the three capacitances  $C_F$ ,  $C_{P1}$  and  $C_{P2}$  are initially charged at the source voltage  $V_A$  (refer to the equivalent circuit reported in Figure 18): A charge sharing phenomenon is installed when the sampling phase is started (A/D switch close).

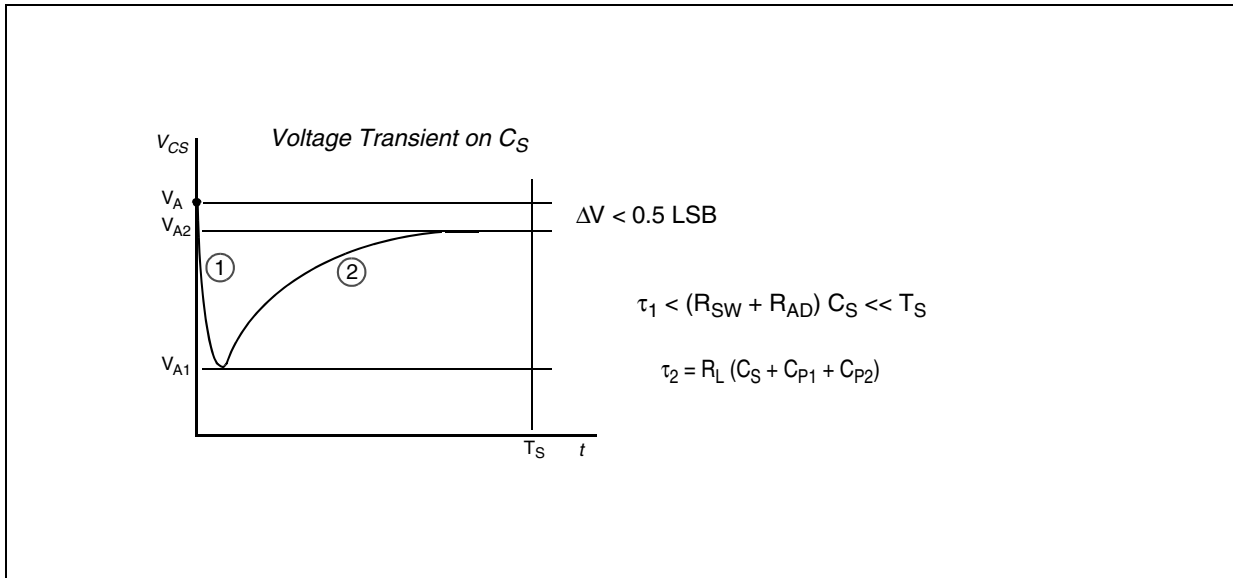

Figure 20. Transient behavior during sampling phase

In particular two different transient periods can be distinguished:

1. A first and quick charge transfer from the internal capacitance  $C_{P1}$  and  $C_{P2}$  to the sampling capacitance  $C_S$  occurs ( $C_S$  is supposed initially completely discharged): considering a worst case (since the time constant in reality would be faster) in which  $C_{P2}$  is reported in parallel to  $C_{P1}$  (call  $C_P = C_{P1} + C_{P2}$ ), the two capacitances  $C_P$  and  $C_S$  are in series, and the time constant is

**Eqn. 5**

$$\tau_1 = (R_{SW} + R_{AD}) \cdot \frac{C_P \cdot C_S}{C_P + C_S}$$

Equation 5 can again be simplified considering only  $C_S$  as an additional worst condition. In reality, the transient is faster, but the A/D converter circuitry has been designed to be robust also in the very worst case: the sampling time  $T_S$  is always much longer than the internal time constant:

**Eqn. 6**

$$\tau_1 < (R_{SW} + R_{AD}) \cdot C_S \ll T_S$$

The charge of  $C_{P1}$  and  $C_{P2}$  is redistributed also on  $C_S$ , determining a new value of the voltage  $V_{A1}$  on the capacitance according to Equation 7:

**Eqn. 7**

$$V_{A1} \cdot (C_S + C_{P1} + C_{P2}) = V_A \cdot (C_{P1} + C_{P2})$$

2. A second charge transfer involves also  $C_F$  (that is typically bigger than the on-chip capacitance) through the resistance  $R_L$ : again considering the worst case in which  $C_{P2}$  and  $C_S$  were in parallel to  $C_{P1}$  (since the time constant in reality would be faster), the time constant is:

**Eqn. 8**

$$\tau_2 < R_L \cdot (C_S + C_{P1} + C_{P2})$$

In this case, the time constant depends on the external circuit: in particular imposing that the transient is completed well before the end of sampling time  $T_S$ , a constraints on  $R_L$  sizing is obtained:

**Eqn. 9**

$$10 \cdot \tau_2 = 10 \cdot R_L \cdot (C_S + C_{P1} + C_{P2}) < T_S$$

Of course,  $R_L$  shall be sized also according to the current limitation constraints, in combination with  $R_S$  (source impedance) and  $R_F$  (filter resistance). Being  $C_F$  definitively bigger than  $C_{P1}$ ,  $C_{P2}$  and  $C_S$ , then the final voltage  $V_{A2}$  (at the end of the charge transfer transient) will be much higher than  $V_{A1}$ . Equation 10 must be respected (charge balance assuming now  $C_S$  already charged at  $V_{A1}$ ):

**Eqn. 10**

$$V_{A2} \cdot (C_S + C_{P1} + C_{P2} + C_F) = V_A \cdot C_F + V_{A1} \cdot (C_{P1} + C_{P2} + C_S)$$

The two transients above are not influenced by the voltage source that, due to the presence of the  $R_F C_F$  filter, is not able to provide the extra charge to compensate the voltage drop on  $C_S$  with respect to the ideal source  $V_A$ ; the time constant  $R_F C_F$  of the filter is very high with respect to the sampling time ( $T_S$ ). The filter is typically designed to act as antialiasing.

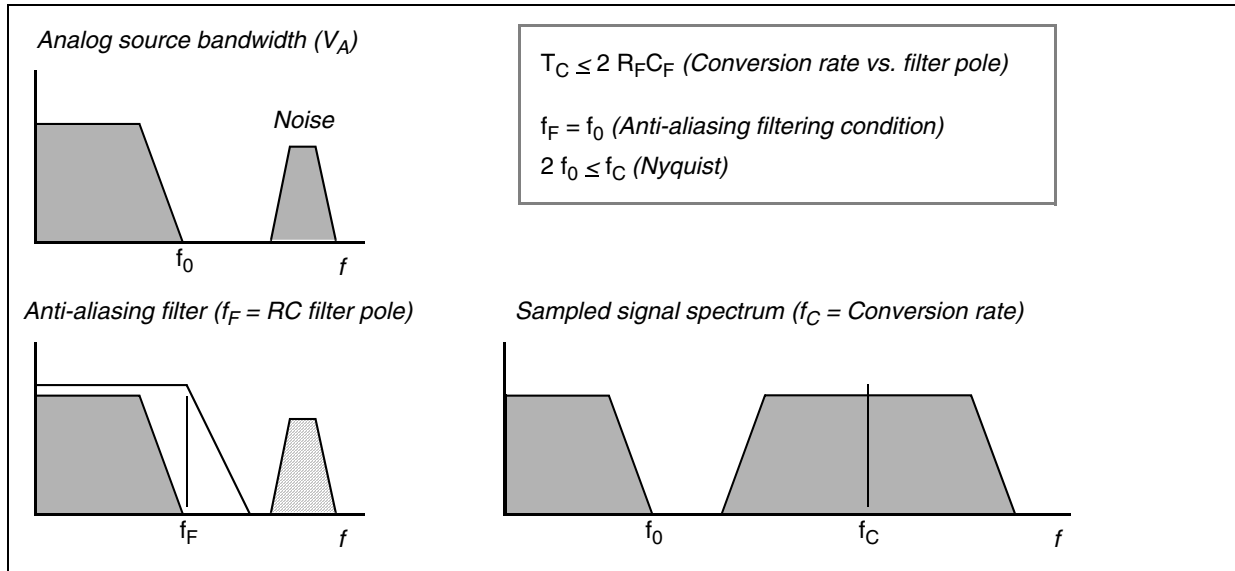

**Figure 21. Spectral representation of input signal**

Calling  $f_0$  the bandwidth of the source signal (and as a consequence the cut-off frequency of the antialiasing filter,  $f_F$ ), according to the Nyquist theorem the conversion rate  $f_C$  must be at least  $2f_0$ ; it means that the constant time of the filter is greater than or at least equal to twice the conversion period ( $T_C$ ). Again the conversion period  $T_C$  is longer than the sampling time  $T_S$ , which is just a portion of it, even when fixed channel continuous conversion mode is selected (fastest conversion rate at a specific channel): in conclusion it is evident that the time constant of the filter  $R_F C_F$  is definitively much higher than the sampling time  $T_S$ , so the charge level on  $C_S$  cannot be modified by the analog signal source during the time in which the sampling switch is closed.

The considerations above lead to impose new constraints on the external circuit, to reduce the accuracy error due to the voltage drop on  $C_S$ ; from the two charge balance equations above, it is simple to derive Equation 11 between the ideal and real sampled voltage on  $C_S$ :

**Eqn. 11**

$$\frac{V_{A2}}{V_A} = \frac{C_{P1} + C_{P2} + C_F}{C_{P1} + C_{P2} + C_F + C_S}$$

From this formula, in the worst case (when  $V_A$  is maximum, that is for instance 5 V), assuming to accept a maximum error of half a count, a constraint is evident on  $C_F$  value:

**ADC\_0 (10-bit)**

**Eqn. 12**

$$C_F > 2048 \cdot C_S$$

**ADC\_1 (12-bit)**

**Eqn. 13**

$$C_F > 8192 \cdot C_S$$

### 3.17.3 ADC electrical characteristics

Table 40. ADC input leakage current

Symbol	C	Parameter	Conditions	Value			Unit		
				Min	Typ	Max			
I <sub>LKG</sub>	CC	C	Input leakage current	T <sub>A</sub> = -40 °C	No current injection on adjacent pin	—	1	—	nA
				T <sub>A</sub> = 25 °C		—	1	—	
				T <sub>A</sub> = 85 °C			3	100	
				T <sub>A</sub> = 105 °C		—	8	200	
				T <sub>A</sub> = 125 °C		—	45	400	

Table 41. ADC\_0 conversion characteristics (10-bit ADC\_0)

Symbol	C	Parameter	Conditions <sup>1</sup>	Value			Unit
				Min	Typ	Max	
V <sub>SS_ADC0</sub>	SR	—	Voltage on VSS_HV_ADC0 (ADC_0 reference) pin with respect to ground (V <sub>SS</sub> ) <sup>2</sup>	—	—	0.1	V
V <sub>DD_ADC0</sub>	SR	—	Voltage on VDD_HV_ADC pin (ADC reference) with respect to ground (V <sub>SS</sub> )	—	—	V <sub>DD</sub> + 0.1	V
V <sub>AINx</sub>	SR	—	Analog input voltage <sup>3</sup>	—	—	V <sub>DD_ADC0</sub> + 0.1	V
I <sub>ADC0pwd</sub>	SR	—	ADC_0 consumption in power down mode	—	—	50	μA
I <sub>ADC0run</sub>	SR	—	ADC_0 consumption in running mode	—	—	5	mA
f <sub>ADC0</sub>	SR	—	ADC_0 analog frequency	—	—	32 + 4%	MHz
Δ <sub>ADC0_SYS</sub>	SR	—	ADC_0 digital clock duty cycle (ipg_clk)	ADCLKSEL = 1 <sup>4</sup>	—	55	%
t <sub>ADC0_PU</sub>	SR	—	ADC_0 power up delay	—	—	1.5	μs
t <sub>ADC0_S</sub>	CC	T	Sample time <sup>5</sup>	f <sub>ADC</sub> = 32 MHz, ADC0_conf_sample_input = 17	—	—	μs
				f <sub>ADC</sub> = 6 MHz, INPSAMP = 255	—	—	
t <sub>ADC0_C</sub>	CC	P	Conversion time <sup>6</sup>	f <sub>ADC</sub> = 32 MHz, ADC_conf_comp = 2	—	—	μs
C <sub>S</sub>	CC	D	ADC_0 input sampling capacitance	—	—	3	pF
C <sub>P1</sub>	CC	D	ADC_0 input pin capacitance 1	—	—	3	pF
C <sub>P2</sub>	CC	D	ADC_0 input pin capacitance 2	—	—	1	pF
C <sub>P3</sub>	CC	D	ADC_0 input pin capacitance 3	—	—	1	pF

**Table 41. ADC\_0 conversion characteristics (10-bit ADC\_0) (continued)**

Symbol	C	Parameter	Conditions <sup>1</sup>	Value			Unit	
				Min	Typ	Max		
R <sub>SW1</sub>	CC	D	Internal resistance of analog source	—	—	3	kΩ	
R <sub>SW2</sub>	CC	D	Internal resistance of analog source	—	—	2	kΩ	
R <sub>AD</sub>	CC	D	Internal resistance of analog source	—	—	2	kΩ	
I <sub>INJ</sub>	SR	—	Input current Injection Current injection on one ADC_0 input, different from the converted one	V <sub>DD</sub> = 3.3 V ± 10%	—	5	mA	
				V <sub>DD</sub> = 5.0 V ± 10%	—5	—		5
INL	CC	T	Absolute value for integral nonlinearity	No overload	—	0.5	1.5	LSB
DNL	CC	T	Absolute differential nonlinearity	No overload	—	0.5	1.0	LSB
OFS	CC	T	Absolute offset error	—	—	0.5	—	LSB
GNE	CC	T	Absolute gain error	—	—	0.6	—	LSB
TUEP	CC	P	Total unadjusted error <sup>7</sup> for precise channels, input only pins	Without current injection	—2	0.6	2	LSB
				With current injection	—3	—	3	
TUEX	CC	T	Total unadjusted error <sup>7</sup> for extended channel	Without current injection	—3	1	3	LSB
				With current injection	—4	—	4	

<sup>1</sup> V<sub>DD</sub> = 3.3 V ± 10% / 5.0 V ± 10%, T<sub>A</sub> = -40 to 125 °C, unless otherwise specified.

<sup>2</sup> Analog and digital V<sub>SS</sub> **must** be common (to be tied together externally).

<sup>3</sup> V<sub>AINx</sub> may exceed V<sub>SS\_ADC0</sub> and V<sub>DD\_ADC0</sub> limits, remaining on absolute maximum ratings, but the results of the conversion will be clamped respectively to 0x000 or 0x3FF.

<sup>4</sup> Duty cycle is ensured by using system clock without prescaling. When ADCLKSEL = 0, the duty cycle is ensured by internal divider by 2.

<sup>5</sup> During the sample time the input capacitance C<sub>S</sub> can be charged/discharged by the external source. The internal resistance of the analog source must allow the capacitance to reach its final voltage level within t<sub>ADC0\_S</sub>. After the end of the sample time t<sub>ADC0\_S</sub>, changes of the analog input voltage have no effect on the conversion result. Values for the sample clock t<sub>ADC0\_S</sub> depend on programming.

<sup>6</sup> This parameter does not include the sample time t<sub>ADC0\_S</sub>, but only the time for determining the digital result and the time to load the result's register with the conversion result.

<sup>7</sup> Total Unadjusted Error: The maximum error that occurs without adjusting Offset and Gain errors. This error is a combination of Offset, Gain and Integral Linearity errors.

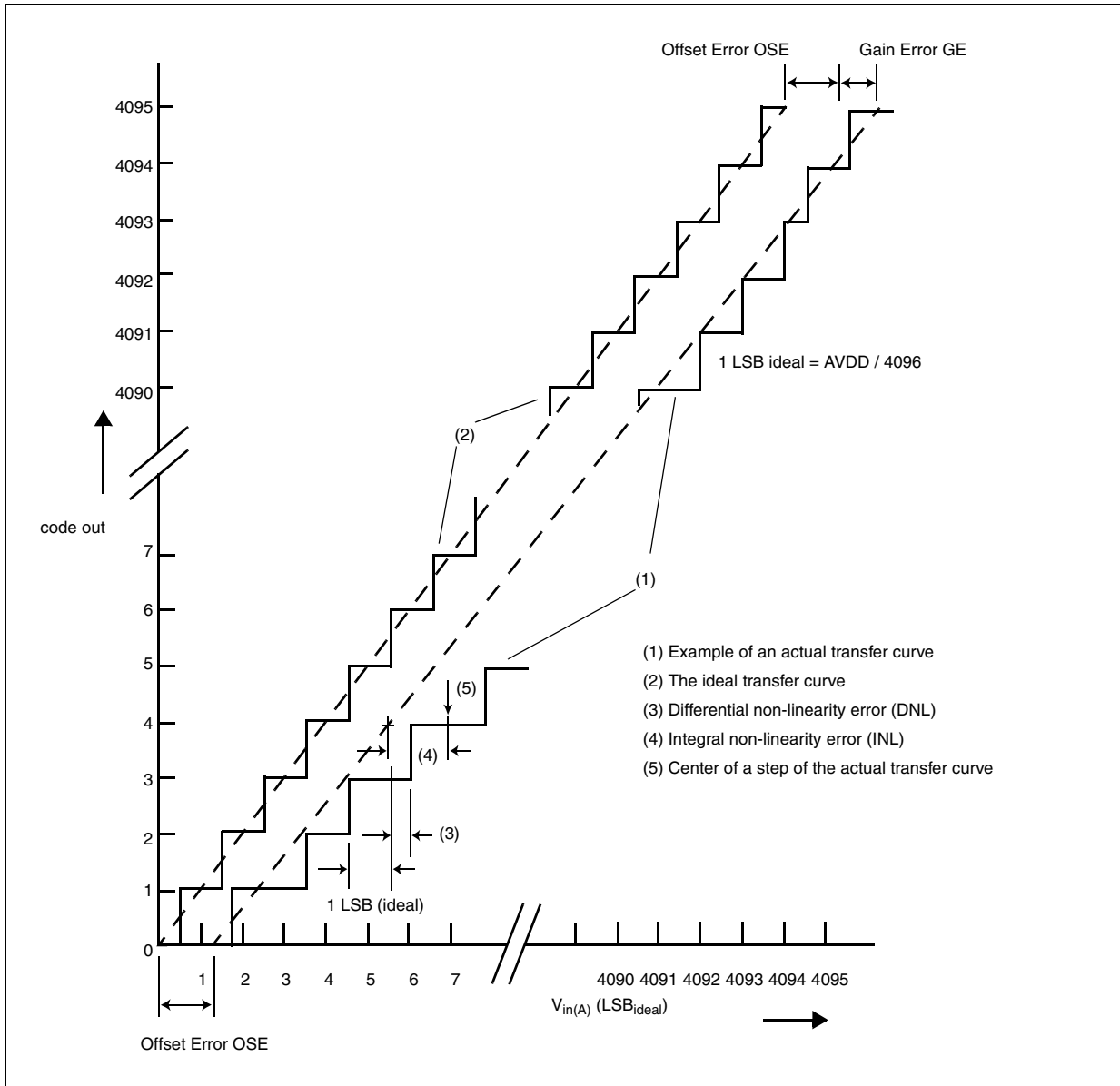

Figure 22. ADC\_1 characteristic and error definitions

Table 42. ADC\_1 conversion characteristics (12-bit ADC\_1)

Symbol	C	Parameter	Conditions <sup>1</sup>	Value			Unit
				Min	Typ	Max	
$V_{SS\_ADC1}$	SR	—	—	-0.1	—	0.1	V
$V_{DD\_ADC1}$	SR	—	—	$V_{DD} - 0.1$	—	$V_{DD} + 0.1$	V

**Table 42. ADC\_1 conversion characteristics (12-bit ADC\_1) (continued)**

Symbol	C	Parameter	Conditions <sup>1</sup>	Value			Unit	
				Min	Typ	Max		
V <sub>AINx</sub>	SR	—	Analog input voltage <sup>3</sup>	—	—	—	V	
I <sub>ADC1pwd</sub>	SR	—	ADC_1 consumption in power down mode	—	—	50	μA	
I <sub>ADC1run</sub>	SR	—	ADC_1 consumption in running mode	—	—	6	mA	
f <sub>ADC1</sub>	SR	—	ADC_1 analog frequency	V <sub>DD</sub> = 3.3 V	3.33	—	20 + 4%	MHz
				V <sub>DD</sub> = 5 V	3.33	—	32 + 4%	
t <sub>ADC1_PU</sub>	SR	—	ADC_1 power up delay	—	—	1.5	μs	
t <sub>ADC1_S</sub>	CC	T	Sample time <sup>4</sup> VDD = 3.3 V	f <sub>ADC1</sub> = 20 MHz, ADC1_conf_sample_input = 12	600	—	—	ns
			Sample time <sup>4</sup> VDD = 5.0 V	f <sub>ADC1</sub> = 32 MHz, ADC1_conf_sample_input = 17	500	—	—	
			Sample time <sup>4</sup> VDD = 3.3 V	f <sub>ADC1</sub> = 3.33 MHz, ADC1_conf_sample_input = 255	—	—	76.2	μs
			Sample time <sup>4</sup> VDD = 5.0 V	f <sub>ADC1</sub> = 3.33 MHz, ADC1_conf_sample_input = 255	—	—	76.2	
t <sub>ADC1_C</sub>	CC	P	Conversion time <sup>5</sup> VDD = 3.3 V	f <sub>ADC1</sub> = 20MHz, ADC1_conf_comp = 0	2.4	—	—	μs
			Conversion time <sup>5</sup> VDD = 5.0 V	f <sub>ADC1</sub> = 32 MHz, ADC1_conf_comp = 0	1.5	—	—	μs
			Conversion time <sup>5</sup> VDD = 3.3 V	f <sub>ADC1</sub> = 13.33 MHz, ADC1_conf_comp = 0	—	—	3.6	μs
			Conversion time <sup>5</sup> VDD = 5.0 V	f <sub>ADC1</sub> = 13.33 MHz, ADC1_conf_comp = 0	—	—	3.6	μs
Δ <sub>ADC1_SYS</sub>	SR	—	ADC_1 digital clock duty cycle	ADCLKSEL = 1 <sup>6</sup>	45	—	55	%
C <sub>S</sub>	CC	D	ADC_1 input sampling capacitance	—	—	—	5	pF
C <sub>P1</sub>	CC	D	ADC_1 input pin capacitance 1	—	—	—	3	pF
C <sub>P2</sub>	CC	D	ADC_1 input pin capacitance 2	—	—	—	1	pF
C <sub>P3</sub>	CC	D	ADC_1 input pin capacitance 3	—	—	—	1.5	pF
R <sub>SW1</sub>	CC	D	Internal resistance of analog source	—	—	—	1	kΩ
R <sub>SW2</sub>	CC	D	Internal resistance of analog source	—	—	—	2	kΩ
R <sub>AD</sub>	CC	D	Internal resistance of analog source	—	—	—	0.3	kΩ

**Table 42. ADC\_1 conversion characteristics (12-bit ADC\_1) (continued)**

Symbol	C	Parameter	Conditions <sup>1</sup>	Value			Unit		
				Min	Typ	Max			
I <sub>INJ</sub>	SR	—	Input current Injection	Current injection on one ADC_1 input, different from the converted one	V <sub>DD</sub> = 3.3 V ± 10%	–5	—	5	mA
					V <sub>DD</sub> = 5.0 V ± 10%	–5	—	5	
INLP	CC	T	Absolute Integral non-linearity-Precise channels	No overload	—	1	3	LSB	
INLX	CC	T	Absolute Integral non-linearity-Extended channels	No overload	—	1.5	5	LSB	
DNL	CC	T	Absolute Differential non-linearity	No overload	—	0.5	1	LSB	
OFS	CC	T	Absolute Offset error	—	—	2	—	LSB	
GNE	CC	T	Absolute Gain error	—	—	2	—	LSB	
TUEP <sup>7</sup>	CC	P	Total Unadjusted Error for precise channels, input only pins	Without current injection	–6	—	6	LSB	
		T		With current injection	–8	—	8		
TUEX <sup>7</sup>	CC	T	Total Unadjusted Error for extended channel	Without current injection	–10	—	10	LSB	
		T		With current injection	–12	—	12		

<sup>1</sup> V<sub>DD</sub> = 3.3 V ± 10% / 5.0 V ± 10%, T<sub>A</sub> = –40 to 125 °C, unless otherwise specified

<sup>2</sup> Analog and digital V<sub>SS</sub> **must** be common (to be tied together externally).

<sup>3</sup> V<sub>AINx</sub> may exceed V<sub>SS\_ADC1</sub> and V<sub>DD\_ADC1</sub> limits, remaining on absolute maximum ratings, but the results of the conversion will be clamped respectively to 0x000 or 0xFFFF.

<sup>4</sup> During the sample time the input capacitance C<sub>S</sub> can be charged/discharged by the external source. The internal resistance of the analog source must allow the capacitance to reach its final voltage level within t<sub>ADC1\_S</sub>. After the end of the sample time t<sub>ADC1\_S</sub>, changes of the analog input voltage have no effect on the conversion result. Values for the sample clock t<sub>ADC1\_S</sub> depend on programming.

<sup>5</sup> This parameter does not include the sample time t<sub>ADC1\_S</sub>, but only the time for determining the digital result and the time to load the result's register with the conversion result.

<sup>6</sup> Duty cycle is ensured by using system clock without prescaling. When ADCLKSEL = 0, the duty cycle is ensured by internal divider by 2.

<sup>7</sup> Total Unadjusted Error: The maximum error that occurs without adjusting Offset and Gain errors. This error is a combination of Offset, Gain and Integral Linearity errors.

## 3.18 On-chip peripherals

### 3.18.1 Current consumption

Table 43. On-chip peripherals current consumption<sup>1</sup>

Symbol	C	Parameter	Conditions		Value	Unit
					Typ	
I <sub>DD_BV(CAN)</sub>	CC	T CAN (FlexCAN) supply current on V <sub>DD_BV</sub>	Bit rate = 500 KB/s	Total (static + dynamic) consumption: <ul style="list-style-type: none"> <li>FlexCAN in loop-back mode</li> <li>XTAL at 8 MHz used as CAN engine clock source</li> <li>Message sending period is 580 μs</li> </ul>	8 * f <sub>periph</sub> + 85	μA
			Bit rate = 125 KB/s		8 * f <sub>periph</sub> + 27	
I <sub>DD_BV(eMIOS)</sub>	CC	T eMIOS supply current on V <sub>DD_BV</sub>	Static consumption: <ul style="list-style-type: none"> <li>eMIOS channel OFF</li> <li>Global prescaler enabled</li> </ul>		29 * f <sub>periph</sub>	
			Dynamic consumption: <ul style="list-style-type: none"> <li>It does not change varying the frequency (0.003 mA)</li> </ul>		3	
I <sub>DD_BV(SCI)</sub>	CC	T SCI (LINFlex) supply current on V <sub>DD_BV</sub>	Total (static + dynamic) consumption: <ul style="list-style-type: none"> <li>LIN mode</li> <li>Baud rate: 20 KB/s</li> </ul>		5 * f <sub>periph</sub> + 31	
I <sub>DD_BV(SPI)</sub>	CC	T SPI (DSPI) supply current on V <sub>DD_BV</sub>	Ballast static consumption (only clocked)		1	
			Ballast dynamic consumption (continuous communication): <ul style="list-style-type: none"> <li>Baud rate: 2 Mb/s</li> <li>Transmission every 8 μs</li> <li>Frame: 16 bits</li> </ul>		16 * f <sub>periph</sub>	
I <sub>DD_BV</sub> (ADC_0/ADC_1)	CC	T ADC_0/ADC_1 supply current on V <sub>DD_BV</sub>	V <sub>DD</sub> = 5.5 V	Ballast static consumption (no conversion)	41 * f <sub>periph</sub>	μA
			V <sub>DD</sub> = 5.5 V	Ballast dynamic consumption (continuous conversion)	46 * f <sub>periph</sub>	
I <sub>DD_HV_ADC0</sub>	CC	T ADC_0 supply current on V <sub>DD_HV_ADC0</sub>	V <sub>DD</sub> = 5.5 V	Analog static consumption (no conversion)	200	mA
			V <sub>DD</sub> = 5.5 V	Analog dynamic consumption (continuous conversion)	3	

**Table 43. On-chip peripherals current consumption<sup>1</sup> (continued)**

Symbol	C	Parameter	Conditions		Value	Unit
					Typ	
I <sub>DD_HV_ADC1</sub>	CC	ADC_1 supply current on V <sub>DD_HV_ADC1</sub>	V <sub>DD</sub> = 5.5 V	Analog static consumption (no conversion)	300 * f <sub>periph</sub>	μA
			V <sub>DD</sub> = 5.5 V	Analog dynamic consumption (continuous conversion)	4	mA
I <sub>DD_HV(FLASH)</sub>	CC	CFlash + DFlash supply current on V <sub>DD_HV</sub>	V <sub>DD</sub> = 5.5 V	—	12	mA
I <sub>DD_BV(PLL)</sub>	CC	PLL supply current on V <sub>DD_BV</sub>	V <sub>DD</sub> = 5.5 V	—	2.5	mA

<sup>1</sup> Operating conditions: T<sub>A</sub> = 25 °C, f<sub>periph</sub> = 8 MHz to 64 MHz

### 3.18.2 DSPI characteristics

Table 44. DSPI characteristics<sup>1</sup>

No.	Symbol	C	Parameter	DSPI0/DSPI11/DSPI5/DSPI6			DSPI2/DSPI				
				Min	Typ	Max	Min	Typ			
1	$t_{SCK}$	SR	SCK cycle time	Master mode (MTFE = 0)	125	—	—	333 <sup>2</sup>	—		
		D			125	—	—	333	—		
		D			83	Master mode (MTFE = 1)	—	—	—	145	—
		D					83	—	—	145	—
		D					83	—	—	145	—
—	SR	D	DSPI digital controller frequency	—	—	$f_{CPU}$	—	—			
2	$t_{CSext}$ <sup>3</sup>	SR	D	CS to SCK delay	Slave mode	32	—	—	32	—	
3	$t_{ASext}$ <sup>4</sup>	SR	D	After SCK delay	Slave mode	$1/f_{DSPI} + 5$	—	—	$1/f_{DSPI} + 5$	—	
		CC	D	SCK duty cycle	Master mode	—	$t_{SCK}/2$	—	—	$t_{SCK}/2$	
4	$t_{SDC}$	SR	D	SCK duty cycle	Slave mode	$t_{SCK}/2$	—	—	—	—	
		SR	D		Slave mode	Slave mode	—	—	—	—	—
5	$t_A$	SR	D	Slave access time	Slave mode	—	—	$1/f_{DSPI} + 70$	—	—	
6	$t_{DI}$	SR	D	Slave SOUT disable time	Slave mode	7	—	—	7	—	
7	$t_{PCSC}$	CC	D	PCSx to $\overline{PCS}$ time	—	13 <sup>5</sup>	—	—	13 <sup>5</sup>	—	
8	$t_{PASC}$	CC	D	$\overline{PCS}$ to PCSx time	—	13 <sup>5</sup>	—	—	13 <sup>5</sup>	—	
9	$t_{SUI}$	SR	D	Data setup time for inputs	Master mode	43	—	—	145	—	
		SR	D	Data hold time for inputs	Slave mode	5	—	—	5	—	
10	$t_{HI}$	SR	D	Data hold time for inputs	Master mode	0	—	—	0	—	
		SR	D	Data hold time for inputs	Slave mode	2 <sup>6</sup>	—	—	2 <sup>6</sup>	—	
11	$t_{SUO}$ <sup>7</sup>	CC	D	Data valid after SCK edge	Master mode	—	—	32	—	—	
		CC	D	Data valid after SCK edge	Slave mode	—	—	52	—	—	
12	$t_{HO}$ <sup>7</sup>	CC	D	Data hold time for outputs	Master mode	0	—	—	0	—	
		CC	D	Data hold time for outputs	Slave mode	8	—	—	13	—	

- 1 Operating conditions:  $C_{out} = 10$  to  $50$  pF,  $Slew_{IN} = 3.5$  to  $15$  ns.
- 2 For DSPI4, if SOUT is mapped to a SLOW pad while SCK is mapped to a MEDIUM pad (or vice versa), the minimum cycle time should be calculated based on the rise and fall times of the SLOW pad. For MTFE=1, SOUT must not be mapped to a SLOW pad. For MTFE=1, SOUT must not be mapped to a MEDIUM pad.
- 3 The  $t_{csc}$  delay value is configurable through a register. When configuring  $t_{csc}$  (using PCSSCK and CSSCK fields in DSPICR1), the  $t_{csc}$  delay between internal CS and internal SCK must be higher than  $\Delta t_{csc}$  to ensure positive  $t_{CS_{Cext}}$ .
- 4 The  $t_{asc}$  delay value is configurable through a register. When configuring  $t_{asc}$  (using PASC and ASC fields in DSPI\_CTAR1), the  $t_{asc}$  delay between internal CS and internal SCK must be higher than  $\Delta t_{asc}$  to ensure positive  $t_{AS_{Cext}}$ .
- 5 For DSPIx\_CTARn[PCSSCK] = 11.
- 6 This delay value corresponds to SMPLE\_PT = 00b which is bit 9 and 8 of DSPI\_MCR register.
- 7 SCK and SOUT are configured as MEDIUM pad.

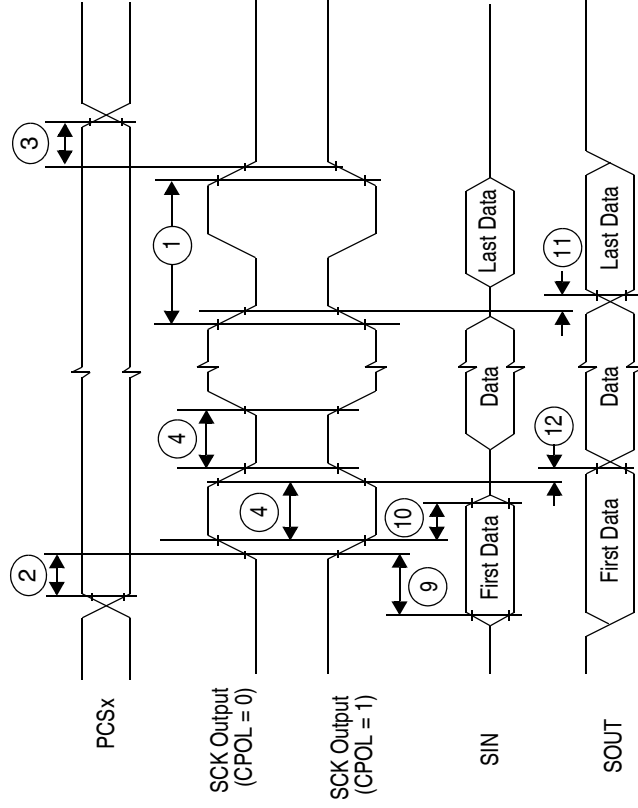

Note: Numbers shown reference [Table 44](#).

**Figure 23. DSPI classic SPI timing — master, CPHA = 0**

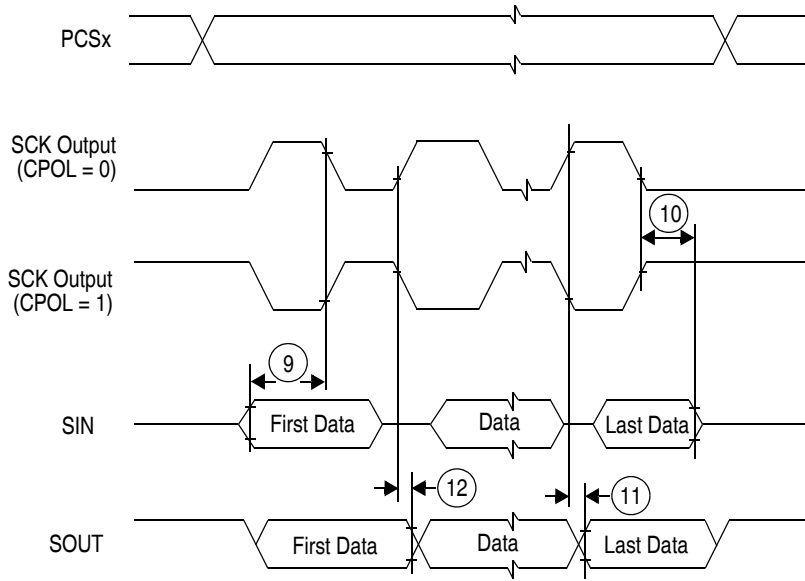

Note: Numbers shown reference [Table 44](#).

**Figure 24. DSPI classic SPI timing — master, CPHA = 1**

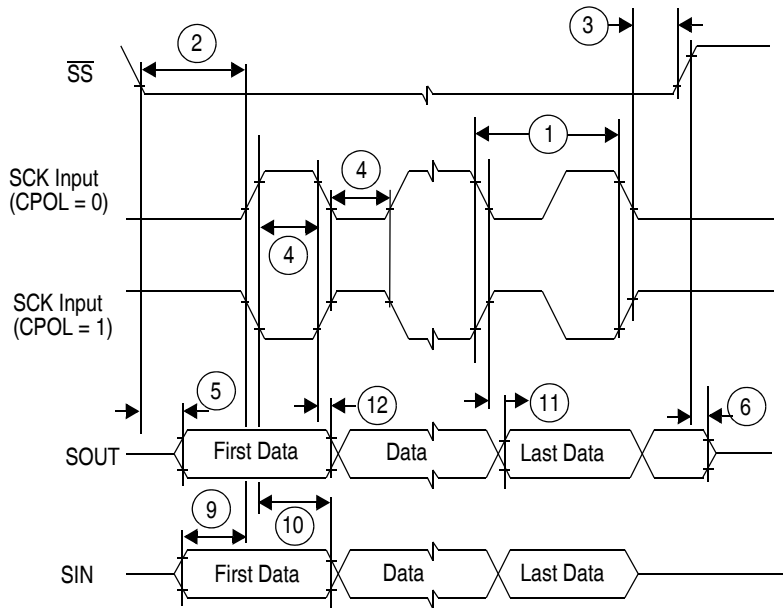

Note: Numbers shown reference [Table 44](#).

**Figure 25. DSPI classic SPI timing — slave, CPHA = 0**

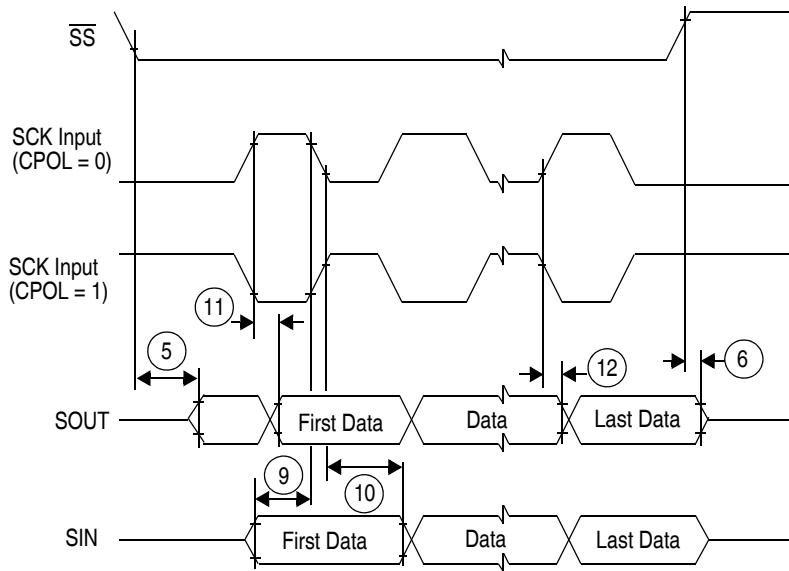

Note: Numbers shown reference [Table 44](#).

**Figure 26. DSPI classic SPI timing — slave, CPHA = 1**

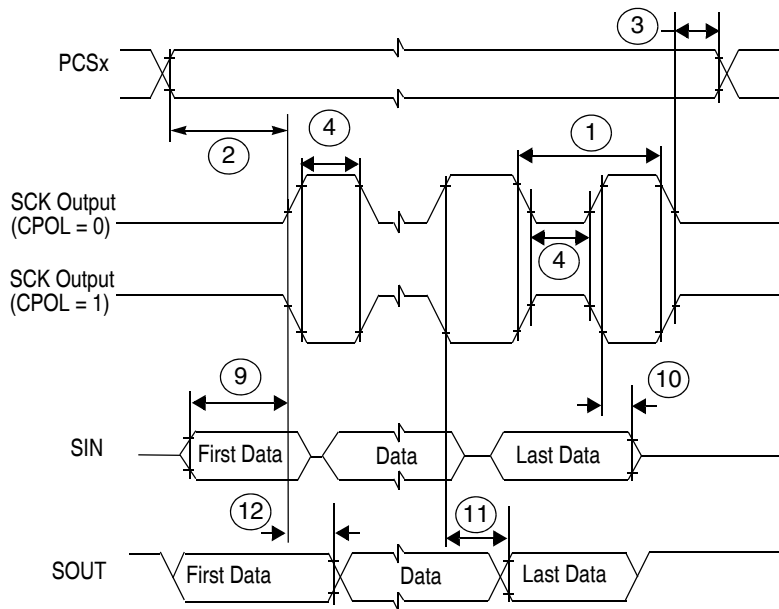

Note: Numbers shown reference [Table 44](#).

**Figure 27. DSPI modified transfer format timing — master, CPHA = 0**

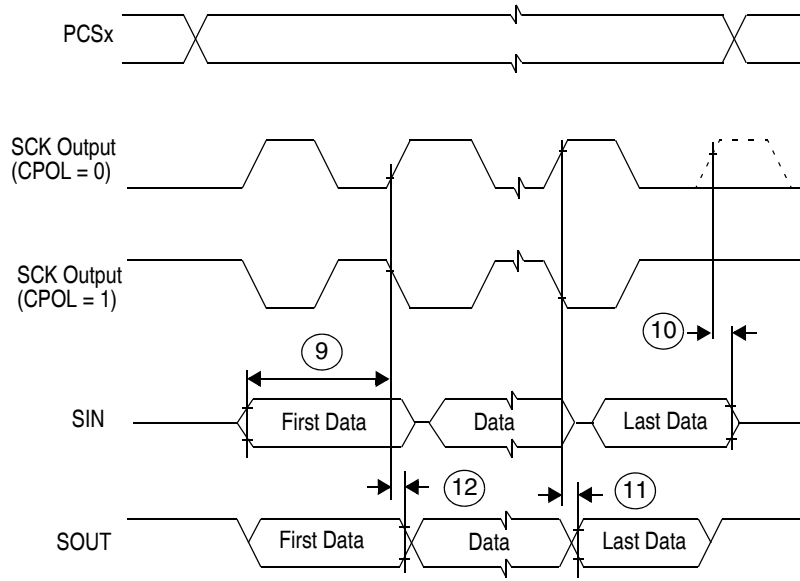

Note: Numbers shown reference [Table 44](#).

**Figure 28. DSPI modified transfer format timing — master, CPHA = 1**

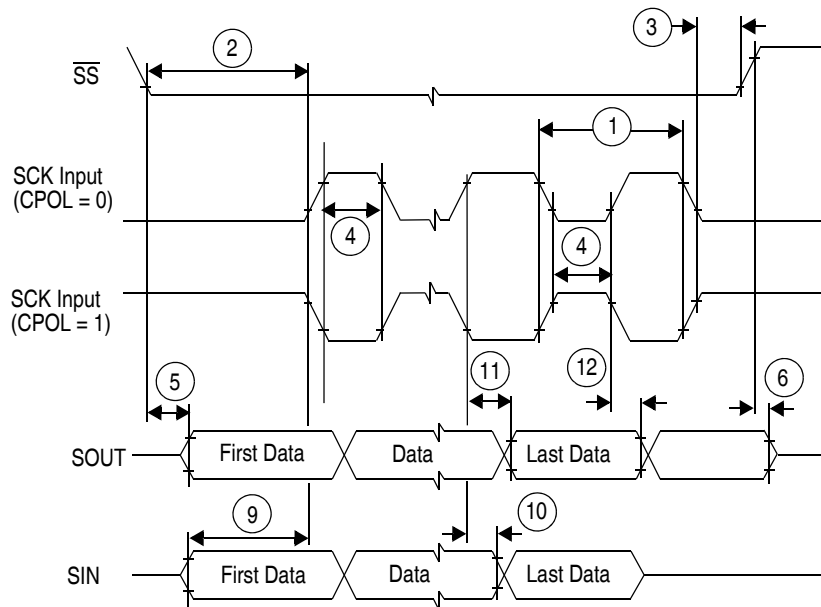

Note: Numbers shown reference [Table 44](#).

**Figure 29. DSPI modified transfer format timing — slave, CPHA = 0**

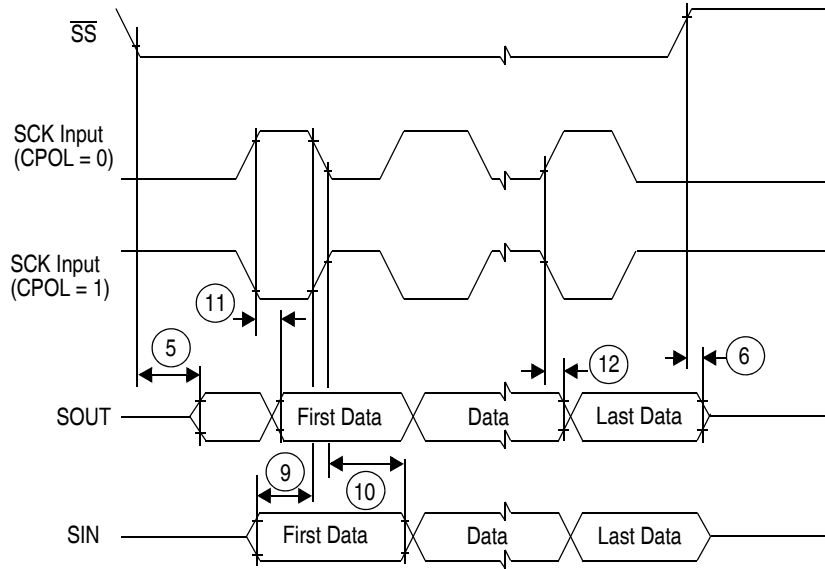

Note: Numbers shown reference [Table 44](#).

**Figure 30. DSPI modified transfer format timing — slave, CPHA = 1**

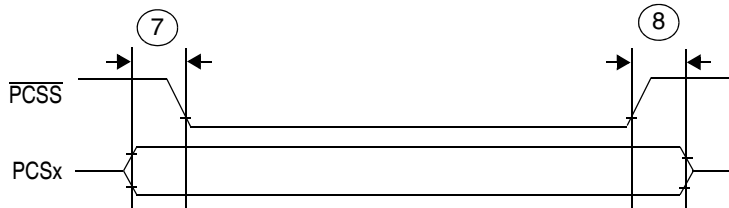

Note: Numbers shown reference [Table 44](#).

**Figure 31. DSPI PCS strobe ( $\overline{PCSS}$ ) timing**

### 3.18.3 JTAG characteristics

**Table 45. JTAG characteristics**

No.	Symbol	C	Parameter	Value			Unit	
				Min	Typ	Max		
1	$t_{JCYC}$	CC	D	TCK cycle time	64	—	—	ns
2	$t_{TDIS}$	CC	D	TDI setup time	15	—	—	ns
3	$t_{TDIH}$	CC	D	TDI hold time	5	—	—	ns

**Table 45. JTAG characteristics (continued)**

No.	Symbol	C	Parameter	Value			Unit	
				Min	Typ	Max		
4	$t_{TMSS}$	CC	D	TMS setup time	15	—	—	ns
5	$t_{TMSH}$	CC	D	TMS hold time	5	—	—	ns
6	$t_{TDOV}$	CC	D	TCK low to TDO valid	—	—	33	ns
7	$t_{TDOI}$	CC	D	TCK low to TDO invalid	6	—	—	ns

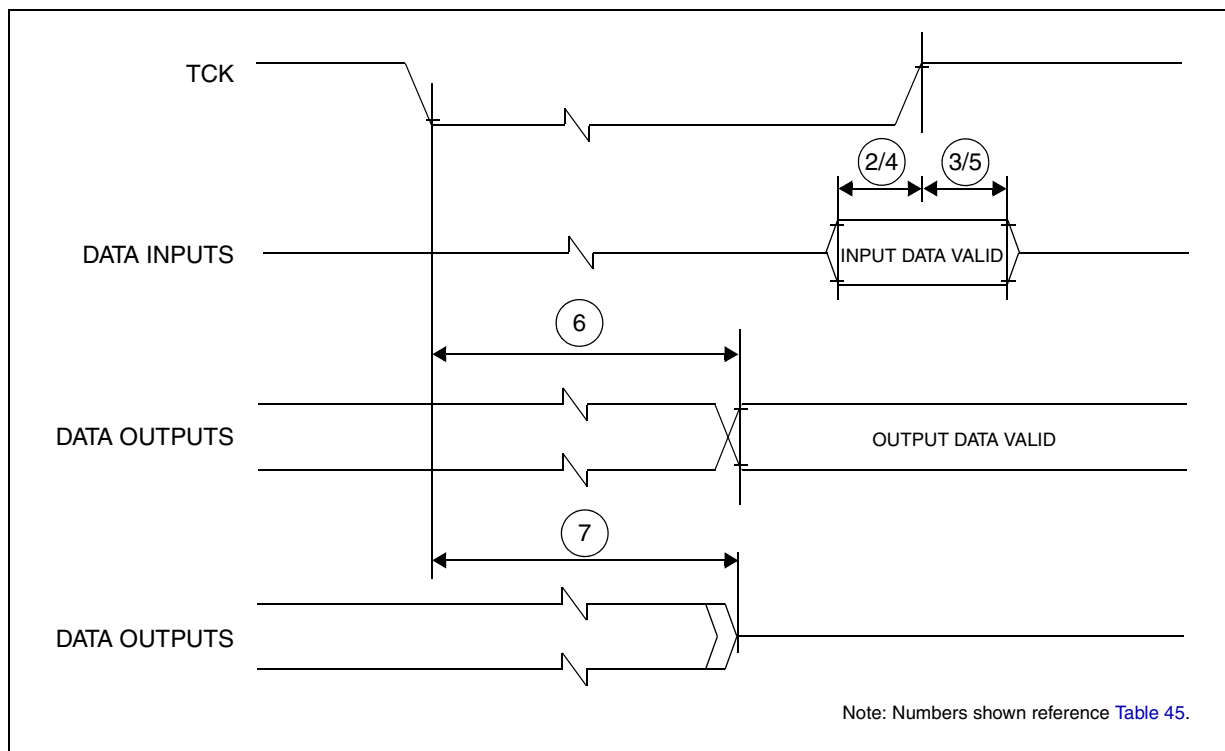

**Figure 32. Timing diagram — JTAG boundary scan**

## 4 Package characteristics

### 4.1 Package mechanical data

#### 4.1.1 176 LQFP

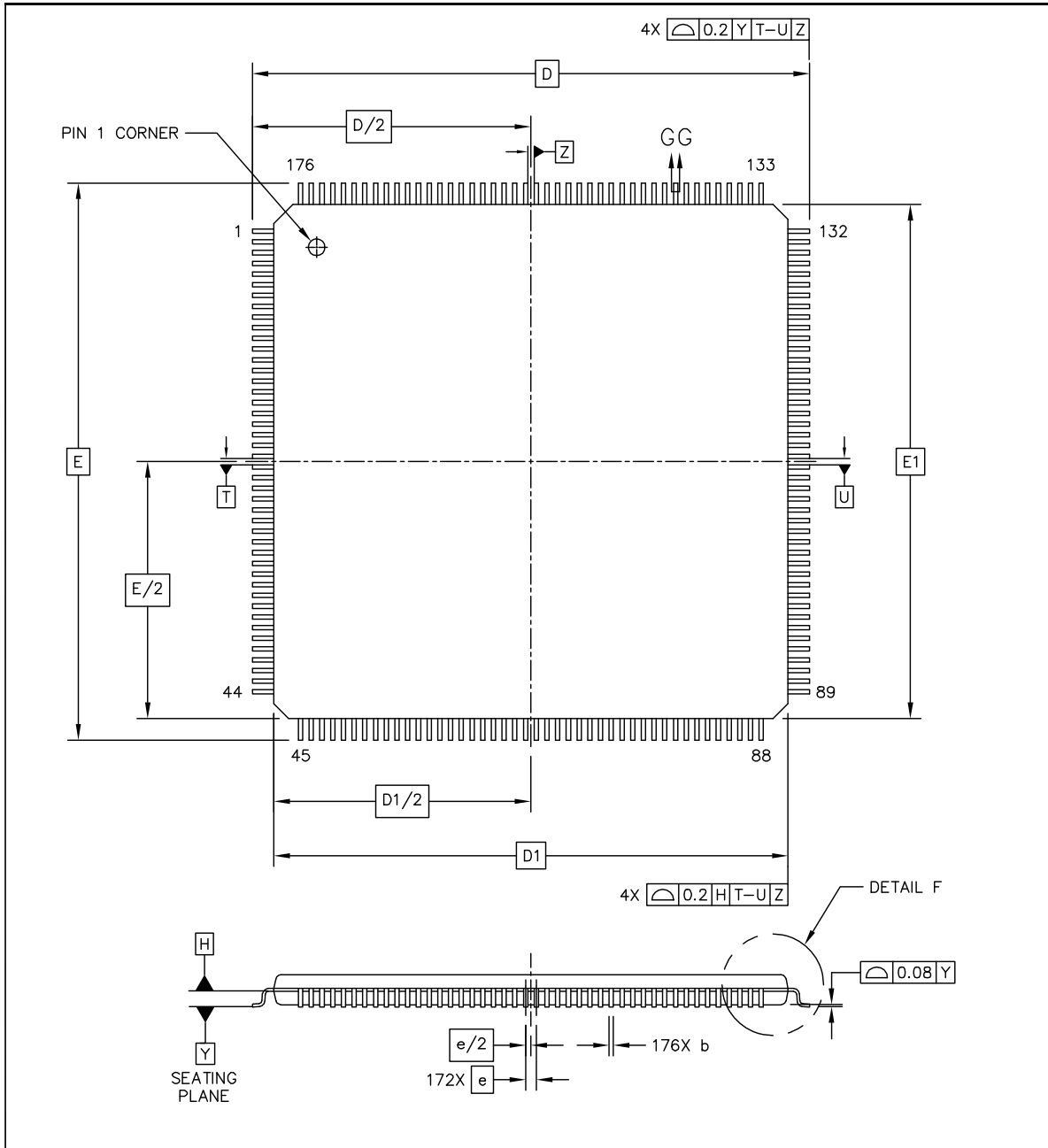

Figure 33. 176 LQFP package mechanical drawing (Part 1 of 3)

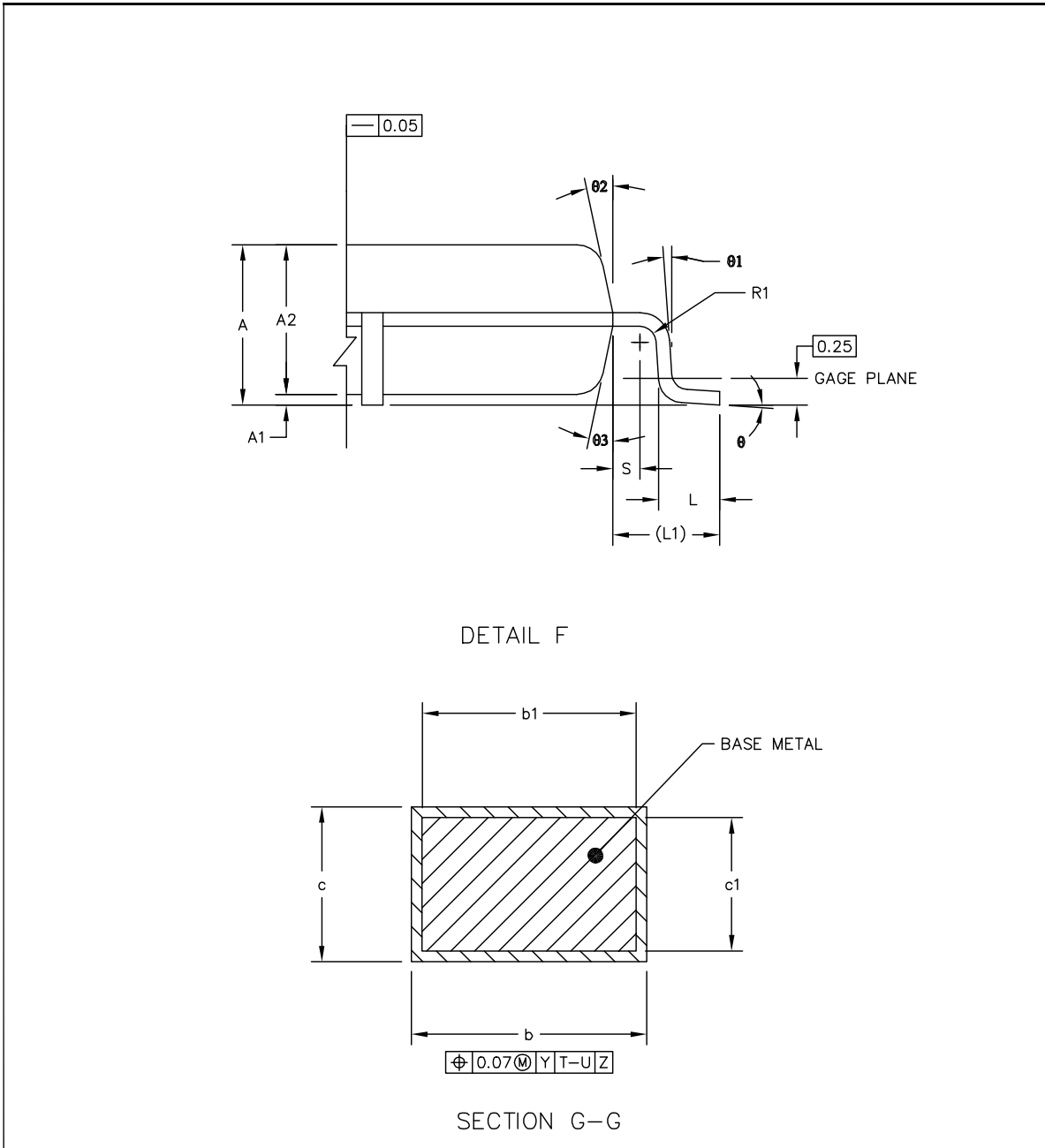

Figure 34. 176 LQFP package mechanical drawing (Part 2 of 3)

NOTES:											
1. DIMENSIONS D1 AND E1 DO NOT INCLUDE MOLD PROTRUSION. ALLOWABLE PROTRUSION IS 0.25MM PER SIDE. DIMENSIONS D1 AND E1 DO INCLUDE MOLD MISMATCH AND ARE DETERMINED AT DATUM PLANE DATUM H.											
2. DIMENSION b DOES NOT INCLUDE DAMBAR PROTRUSION. DAMBAR PROTRUSION. ALLOWABLE DAMBAR PROTRUSION SHALL NOT CAUSE THE LEAD WIDTH TO EXCEED THE MAXIMUM b DIMENSION BY MORE THEN 0.08MM. DAMBAR CAN NOT BE LOCATED ON THE LOWER RADIUS OR THE FOOT. MINIMUM BETWEEN PROTRUSION AND AN ADJACENT LEAD IS 0.07MM FOR 0.4MM AND 0.5MM PITCH PACKAGES.											
DIM	MIN	NOM	MAX	DIM	MIN	NOM	MAX	DIM	MIN	NOM	MAX
A	---		1.6	L1		1 REF					
A1	0.05		0.15	R1	0.08		---				
A2	1.35	1.4	1.45	R2	0.08		0.2				
b	0.17	0.22	0.27	S		0.2 REF					
b1	0.17	0.2	0.23	$\theta$	0°	3.5°	7°				
c	0.09		0.2	$\theta 1$	0°		---				
c1	0.09		0.16	$\theta 2$	11°	12°	13°				
D		26 BSC		$\theta 3$	11°	12°	13°				
D1		24 BSC									
e		0.5 BSC									
E		26 BSC									
E1		24 BSC									
L	0.45	0.6	0.75								
					UNIT	DIMENSION AND TOLERANCES			REFERANCE DOCUMENT		
					MM	ASME Y14.5M			64-06-280-1392		

**Figure 35. 176 LQFP package mechanical drawing (Part 3 of 3)**



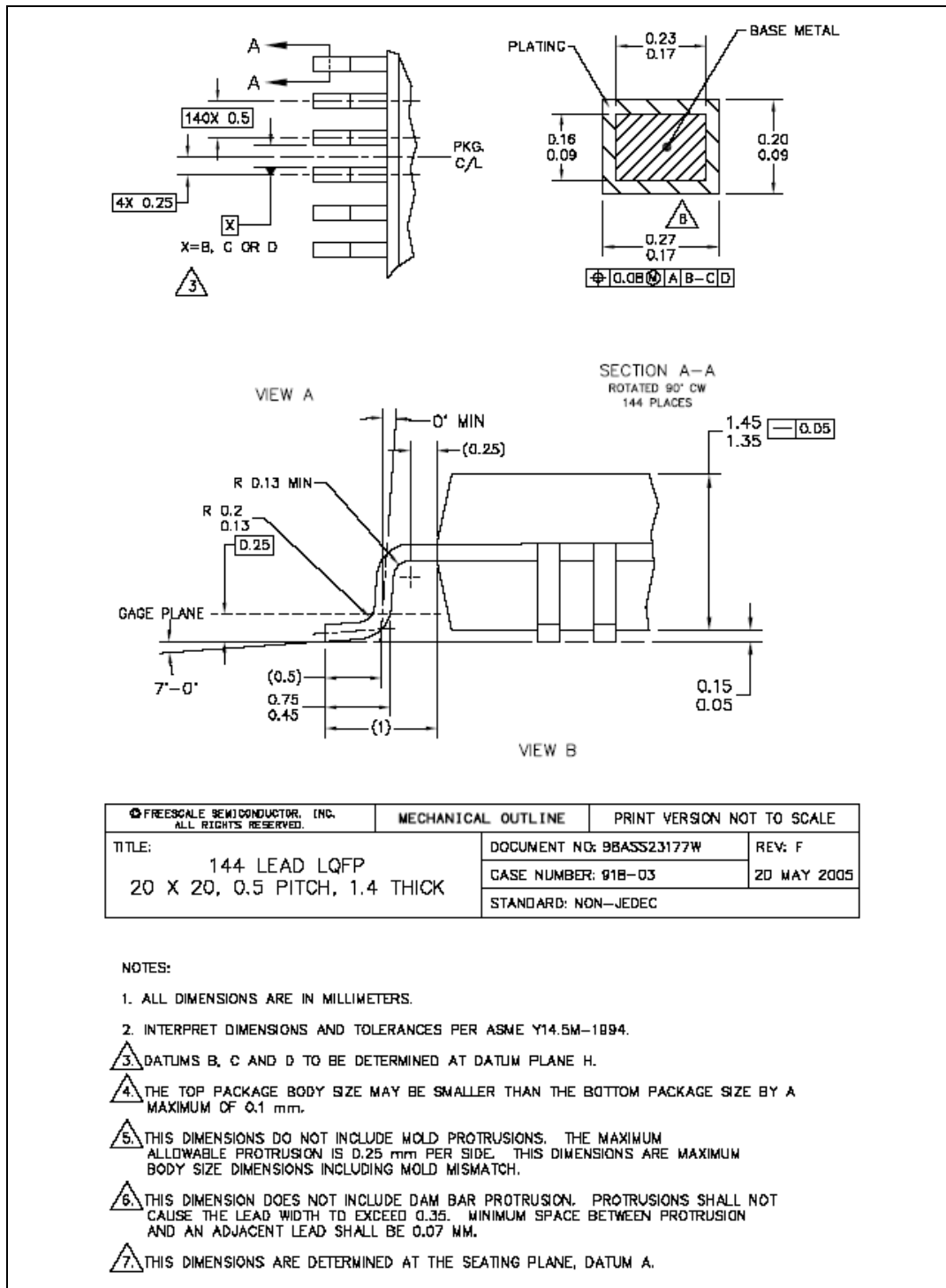

Figure 37. 144 LQFP package mechanical drawing (Part 2 of 2)

### 4.1.3 100 LQFP

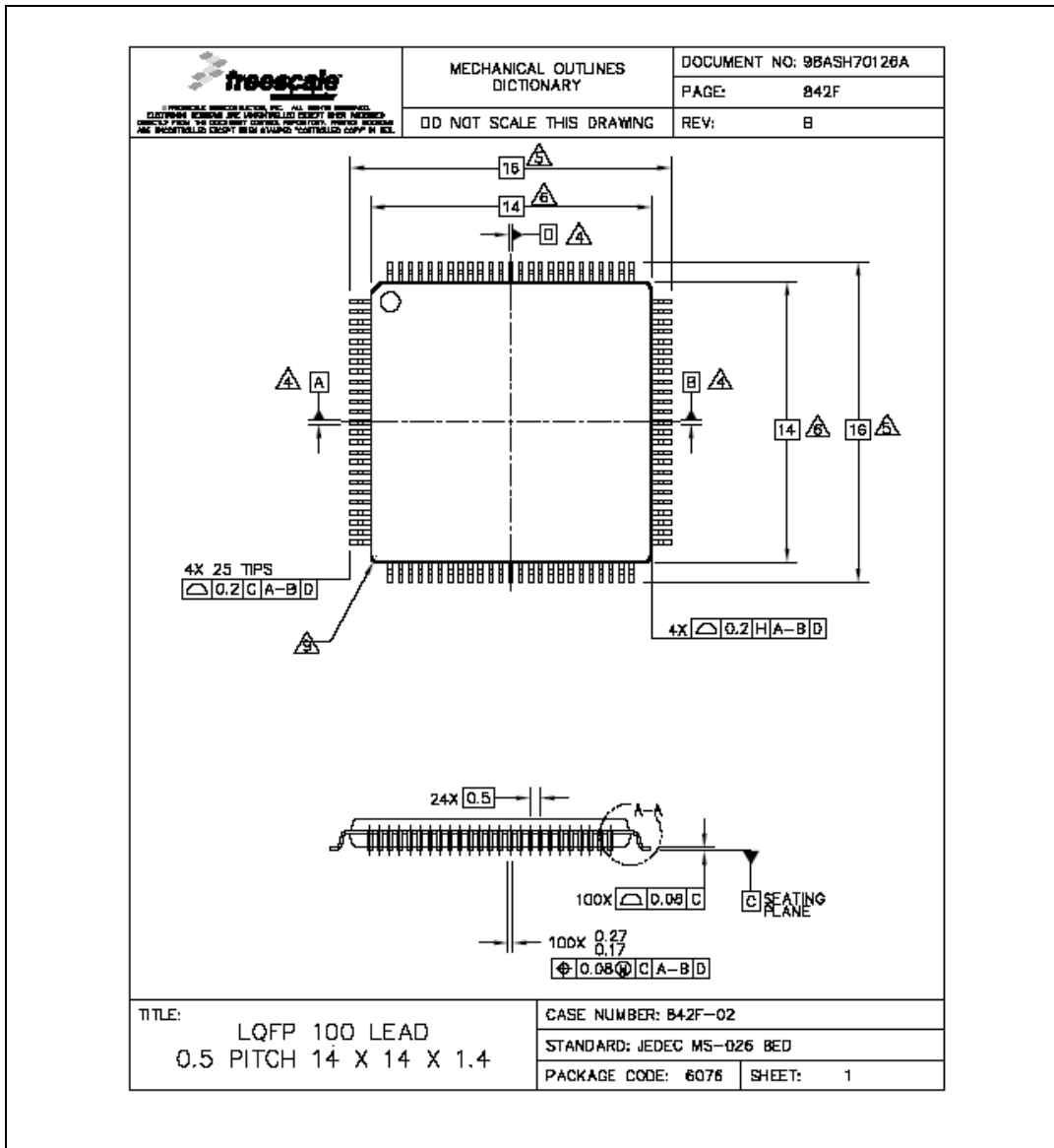
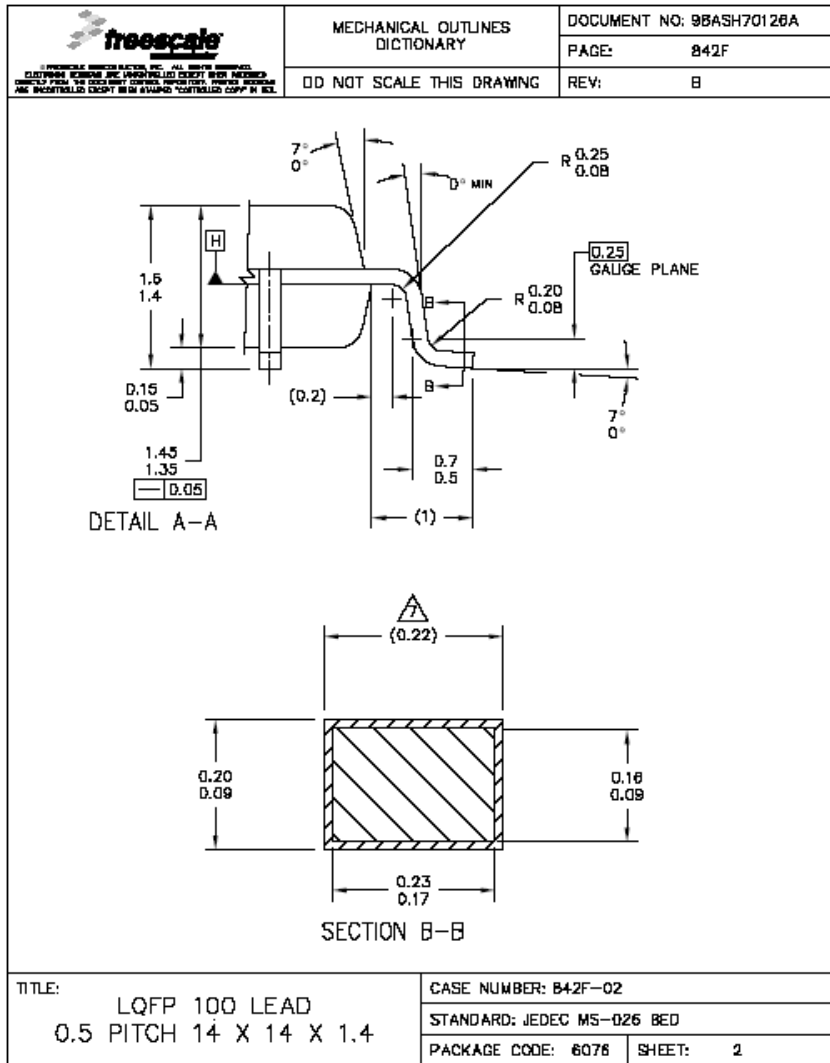

Figure 38. 100 LQFP package mechanical drawing (Part 1 of 3)



**Figure 39. 100 LQFP package mechanical drawing (Part 2 of 3)**

 <small>© FREESCALE SEMICONDUCTOR, INC. ALL RIGHTS RESERVED.          DRAWING IS UNCONTROLLED EXCEPT WHEN REFERRED          DIRECTLY FROM THE SOLE SOURCE CONTROL. REVISIONS, PARTS AND ACCESSORIES          ARE UNCONTROLLED EXCEPT WHEN SHOWN "CONTROLLED COPY" IN BOM.</small>	MECHANICAL OUTLINES DICTIONARY	DOCUMENT NO: 98ASH70126A
	DD NOT SCALE THIS DRAWING	PAGE: 842F REV: B
<p>1. DIMENSIONS AND TOLERANCING PER ASME Y14.5M-1994.</p> <p>2. CONTROLLING DIMENSION: MILLIMETER</p> <p>3. DATUM PLANE H IS LOCATED AT BOTTOM OF LEAD AND IS COINCIDENT WITH THE LEAD WHERE THE LEAD EXITS THE PLASTIC BODY AT THE BOTTOM OF THE PARTING LINE.</p> <p>4. DATUMS A, B, AND D TO BE DETERMINED AT DATUM PLANE H.</p> <p>5. DIMENSIONS TO BE DETERMINED AT SEATING PLANE, DATUM C.</p> <p>6. DIMENSIONS DO NOT INCLUDE MOLD PROTRUSION. ALLOWABLE PROTRUSION IS 0.25 PER SIDE. DIMENSIONS DO INCLUDE MOLD MISMATCH AND ARE DETERMINED AT DATUM PLANE H.</p> <p>7. DIMENSION DOES NOT INCLUDE DAMBAR PROTRUSION. DAMBAR PROTRUSION SHALL NOT CAUSE THE LEAD WIDTH TO EXCEED 0.35. DAMBAR CAN NOT BE LOCATED ON THE LOWER RADIUS OR THE FOOT. MINIMUM SPACE BETWEEN PROTRUSION AND AN ADJACENT LEAD IS 0.07.</p> <p>8. MINIMUM SOLDER PLATE THICKNESS SHALL BE 0.0076.</p> <p>9. EXACT SHAPE OF EACH CORNER MAY VARY FROM DEPICTION.</p>		
TITLE: LQFP 100 LEAD 0.5 PITCH 14 X 14 X 1.4		CASE NUMBER: 842F-02 STANDARD: JEDEC MS-026 BCD PACKAGE CODE: 8076 SHEET: 3

Figure 40. 100 LQFP package mechanical drawing (Part 3 of 3)

# 5 Ordering information

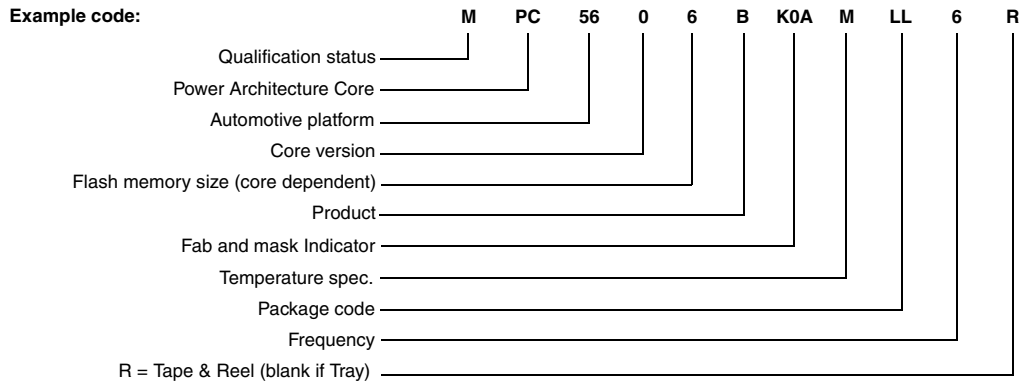

**Qualification status**

M = General market qualified  
 S = Automotive qualified  
 P = Engineering samples

**Automotive Platform**

56 = Power Architecture in 90nm

**Core version**

0 = e200z0

**Flash memory size (for z0 core)**

5 = 768 KB  
 6 = 1024 KB

**Product**

B = Body

**Fab and mask Indicator**

K = TSMC Fab  
 0 = Version of the maskset  
 A = Mask set indicator (Blank = 1st production maskset, A = 2nd, B = 3rd, etc)

**Temperature spec.**

C = -40 to 85 °C  
 V = -40 to 105 °C  
 M = -40 to 125 °C

**Package code**

LL = 100 LQFP  
 LQ = 144 LQFP  
 LU = 176 LQFP

**Frequency**

4 = Up to 48 MHz  
 6 = Up to 64 MHz

**Note:** Not all options are available on all devices.

**Figure 41. Commercial product code structure**

## 6 Revision history

Table 46. Revision history

Revision	Date	Description of changes
1	22 Apr 2011	Initial release.
2	15 May 2013	<p>Changed device number to MPC5606BK.</p> <p>In Table 2 (Functional port pins), updated PA[11] AF2, PD[13] AF2, and PH[11] AF3 I/O direction to "I/O".</p> <p>In Table 3 (Pad types), corrected "Fast" in the "S" row to "Slow."</p> <p>In Table 5 (PAD3V5V field description), updated footnote 2.</p> <p>In Table 6 (OSCILLATOR_MARGIN field description), updated footnote 2.</p> <p>Inserted Section 3.2.3, NVUSRO[WATCHDOG_EN] field description.</p> <p>In Table 8 (Absolute maximum ratings), Table 9 (Recommended operating conditions (3.3 V)), and Table 10 (Recommended operating conditions (5.0 V)), corrected the parameter description for <math>V_{DD\_ADC}</math> to "Voltage on VDD_HV_ADC0, VDD_HV_ADC1 (ADC reference) with respect to ground (<math>V_{SS}</math>)"</p> <p>In Section 3.6.1, I/O pad types bullet item, removed Nexus reference.</p> <p>In Table 12 (I/O input DC electrical characteristics), added specifications for 85 °C.</p> <p>In Table 13 (I/O pull-up/pull-down DC electrical characteristics), Table 14 (SLOW configuration output buffer electrical characteristics), Table 15 (MEDIUM configuration output buffer electrical characteristics), and Table 16 (FAST configuration output buffer electrical characteristics), changed sentence in footnote 2 to "All pads but RESET are configured in input or in high impedance state."</p> <p>In Table 15 (MEDIUM configuration output buffer electrical characteristics), for <math>V_{OL}</math>, changed <math>I_{OH}</math> to <math>I_{OL}</math>.</p> <p>Updated Table 20 (I/O weight).</p> <p>In Table 21 (Reset electrical characteristics) changed sentence in footnote 4 to "All pads but RESET are configured in input or in high impedance state."</p> <p>In Table 22 (Voltage regulator electrical characteristics), corrected the maximum value for <math>I_{DD\_BV}</math> in Table 22 (Voltage regulator electrical characteristics) to 300 mA.</p> <p>In Table 23 (Low voltage monitor electrical characteristics), changed <math>V_{PORUP}</math> classification tag from "P" (Production testing guaranteed) to "D" (Design simulation). Changed <math>V_{LVDHV3BH}</math> classification tag from "P" (Production testing guaranteed) to "T" (Design characterization).</p> <p>In Table 23 (Low voltage monitor electrical characteristics), changed <math>V_{LVDHV3L}</math>, <math>V_{LVDHV3BL}</math> minimums from 2.7 V to 2.6 V.</p>

**Table 46. Revision history (continued)**

Revision	Date	Description of changes
2 (cont.)	15 May 2013	<p>In <a href="#">Table 24 (Electrical characteristics in different application modes)</a>,</p> <ul style="list-style-type: none"> <li>— Changed <math>I_{DDMAX}</math> Typ to 81 mA and <math>I_{DDMAX}</math> Typ to 130 mA.</li> <li>— Changed <math>I_{DDRUN}</math> Typ for fCPU = 32 MHz to 40 mA.</li> <li>— Changed <math>I_{DDRUN}</math> Typ for fCPU = 48 MHz to 54 mA. Added <math>I_{DDRUN}</math> Max of 96 mA.</li> <li>— Changed <math>I_{DDRUN}</math> Typ for fCPU = 64 MHz to 67 mA. Added <math>I_{DDRUN}</math> Max of 120 mA.</li> <li>— Changed <math>I_{DDHALT}</math> at <math>T_A = 25\text{ °C}</math> Typ to 10 mA and <math>I_{DDHALT}</math> Max to 15 mA.</li> <li>— Changed <math>I_{DDHALT}</math> at <math>T_A = 125\text{ °C}</math> Typ to 15 mA and <math>I_{DDHALT}</math> Max to 28 mA.</li> <li>— Changed <math>I_{DDSTOP}</math> <math>T_A</math> temperature from <math>-40\text{ °C}</math> to <math>25\text{ °C}</math>.</li> <li>— Changed <math>I_{DDSTOP}</math> at <math>T_A = 25\text{ °C}</math> Typ to 130 <math>\mu</math>A and <math>I_{DDSTOP}</math> Max to 500 <math>\mu</math>A.</li> <li>— Changed <math>I_{DDSTOP}</math> at <math>T_A = 55\text{ °C}</math> Typ to 180 <math>\mu</math>A.</li> <li>— Changed <math>I_{DDSTOP}</math> at <math>T_A = 85\text{ °C}</math> Typ to 1 mA and <math>I_{DDSTOP}</math> Max to 5 mA.</li> <li>— Changed <math>I_{DDSTOP}</math> at <math>T_A = 105\text{ °C}</math> Typ to 3 mA and <math>I_{DDSTOP}</math> Max to 9 mA.</li> <li>— Changed <math>I_{DDSTOP}</math> at <math>T_A = 125\text{ °C}</math> Typ to 5 mA and <math>I_{DDSTOP}</math> Max to 14 mA.</li> <li>— Changed <math>I_{DDSTBY2}</math> at <math>T_A = 25\text{ °C}</math> Typ to 17 <math>\mu</math>A and Max to 80 <math>\mu</math>A.</li> <li>— Changed <math>I_{DDSTBY2}</math> at <math>T_A = 55\text{ °C}</math> Typ to 30 <math>\mu</math>A.</li> <li>— Changed <math>I_{DDSTBY2}</math> at <math>T_A = 85\text{ °C}</math> Typ to 100 <math>\mu</math>A.</li> <li>— Changed <math>I_{DDSTBY2}</math> at <math>T_A = 105\text{ °C}</math> Typ to 280 <math>\mu</math>A and Max to 950 <math>\mu</math>A.</li> <li>— Changed <math>I_{DDSTBY2}</math> at <math>T_A = 125\text{ °C}</math> Typ to 460 <math>\mu</math>A and Max to 1700 <math>\mu</math>A.</li> <li>— Changed the parameter classification for <math>I_{DDSTANDBY2}</math> (<math>T_A = 125\text{ °C}</math>)</li> <li>— Changed <math>I_{DDSTBY1}</math> at <math>T_A = 25\text{ °C}</math> Typ to 12 <math>\mu</math>A and Max to 50 <math>\mu</math>A.</li> <li>— Changed <math>I_{DDSTBY1}</math> at <math>T_A = 55\text{ °C}</math> Typ to 24 <math>\mu</math>A.</li> <li>— Changed <math>I_{DDSTBY1}</math> at <math>T_A = 85\text{ °C}</math> Typ to 48 <math>\mu</math>A.</li> <li>— Changed <math>I_{DDSTBY1}</math> at <math>T_A = 105\text{ °C}</math> Typ to 150 <math>\mu</math>A and Max to 500 <math>\mu</math>A.</li> <li>— Changed <math>I_{DDSTBY1}</math> at <math>T_A = 125\text{ °C}</math> Typ to 260 <math>\mu</math>A.</li> <li>— Changed the third sentence of Footnote 3 to begin with “The given value is thought to be a <b>worst case value</b> (64 MHz at 125 °C) with all peripherals running.”</li> <li>— Removed footnotes 8 and 9 regarding <math>I_{DDHALT}</math> and <math>I_{DDSTOP}</math></li> <li>— Corrected “C” characteristics to reflect testing status.</li> </ul> <p>In <a href="#">Section 3.10, Flash memory electrical characteristics</a>, removed the "FLASH_BIU settings vs. frequency of operation" table.</p> <p>In <a href="#">Table 28 (Flash power supply DC electrical characteristics)</a>, corrected Footnote 2 to specify 125 °C.</p> <p>In <a href="#">Section 3.14, FMPLL electrical characteristics</a>, changed the text “the main oscillator driver” to “the FXOSC or FIRC sources.”</p> <p>In <a href="#">Table 40 (ADC input leakage current)</a>, added specifications for 85 °C.</p> <p>In <a href="#">Table 44 (DSPI characteristics)</a>, added <math>t_{SCK}</math> specifications for MTFE=1.</p> <p>In <a href="#">Table 44 (DSPI characteristics)</a>, updated specifications 7 and 8 to 13 ns, all DSPIs.</p> <p>in ADC section, corrected <a href="#">Equation 11</a>.</p> <p>In <a href="#">Figure 41 (Commercial product code structure)</a>, added “<b>Note:</b> Not all options are available on all devices.”</p> <p>Removed Section 6, Abbreviations.</p>
3	11 Sep 2013	Updated the temperature in table note 2 in <a href="#">Table 1 (MPC5606BK family comparison)</a> from 105 °C to 125 °C.
4	25 Nov 2015	Updated the Max value current for $I_{ADC0run}$ from 40 mA to 5 mA in <a href="#">Table 41 (ADC_0 conversion characteristics (10-bit ADC_0))</a> .
5	7 Nov 2017	<p>In <a href="#">Table 9 (Recommended operating conditions (3.3 V))</a> added Min value for <math>TV_{DD}</math>.</p> <p>In <a href="#">Table 10 (Recommended operating conditions (5.0 V))</a> added Min value for <math>TV_{DD}</math>.</p> <p>In <a href="#">Table 44 (DSPI characteristics)</a> changed the for DSPI 2 and 4, in MTFE=1 mode from 125 to 145.</p>

**How to Reach Us:**

**Home Page:**

[nxp.com](http://nxp.com)

**Web Support:**

[nxp.com/support](http://nxp.com/support)

Information in this document is provided solely to enable system and software implementers to use NXP products. There are no express or implied copyright licenses granted hereunder to design or fabricate any integrated circuits based on the information in this document. NXP reserves the right to make changes without further notice to any products herein.

NXP makes no warranty, representation, or guarantee regarding the suitability of its products for any particular purpose, nor does NXP assume any liability arising out of the application or use of any product or circuit, and specifically disclaims any and all liability, including without limitation consequential or incidental damages. "Typical" parameters that may be provided in NXP data sheets and/or specifications can and do vary in different applications, and actual performance may vary over time. All operating parameters, including "typicals," must be validated for each customer application by customer's technical experts. NXP does not convey any license under its patent rights nor the rights of others. NXP sells products pursuant to standard terms and conditions of sale, which can be found at the following address: [nxp.com/SalesTermsandConditions](http://nxp.com/SalesTermsandConditions).

NXP, the NXP logo, NXP SECURE CONNECTIONS FOR A SMARTER WORLD, COOLFLUX, EMBRACE, GREENCHIP, HITAG, I2C BUS, ICODE, JCOP, LIFE VIBES, MIFARE, MIFARE CLASSIC, MIFARE DESFire, MIFARE PLUS, MIFARE FLEX, MANTIS, MIFARE ULTRALIGHT, MIFARE4MOBILE, MIGLO, NTAG, ROADLINK, SMARTLX, SMARTMX, STARPLUG, TOPFET, TRENCHMOS, UCODE, Freescale, the Freescale logo, Altivec, C.5, CodeTEST, CodeWarrior, ColdFire, ColdFire+, C.Ware, the Energy Efficient Solutions logo, Kinetis, Layerscape, MagniV, mobileGT, PEG, PowerQUICC, Processor Expert, QorIQ, QorIQ Qonverge, Ready Play, SafeAssure, the SafeAssure logo, StarCore, Symphony, VortiQa, Vybrid, Airfast, BeeKit, BeeStack, CoreNet, Flexis, MXC, Platform in a Package, QUICC Engine, SMARTMOS, Tower, TurboLink, and UMEMS are trademarks of NXP B.V. All other product or service names are the property of their respective owners. Arm, AMBA, Arm Powered, Artisan, Cortex, Jazelle, Keil, SecurCore, Thumb, TrustZone, and IVison are registered trademarks of Arm Limited (or its subsidiaries) in the EU and/or elsewhere. Arm7, Arm9, Arm11, big.LITTLE, CoreLink, CoreSight, DesignStart, Mali, Mbed, NEON, POP, Sensinode, Socrates, ULINK and Versatile are trademarks of Arm Limited (or its subsidiaries) in the EU and/or elsewhere. All rights reserved. Oracle and Java are registered trademarks of Oracle and/or its affiliates. The Power Architecture and Power.org word marks and the Power and Power.org logos and related marks are trademarks and service marks licensed by Power.org.

MPC5606B  
Rev. 5  
11/2017



## Looking for pricing, stock, or lifecycle information?

Click below to explore more details on WIN SOURCE:

 [View SPC5605BK0MLL6 on WIN SOURCE](#)

 [NXP / Nexperia Information](#)

## Optimize Your Supply Chain with WIN SOURCE Solutions

-  Global Sourcing Solution
-  Obsolete Management
-  Cost Control Management
-  Shortage Management
-  Alternative Solution
-  Excess Inventory Management