



THE DATASHEET OF NSP-6-7-01



RIVETS, SCREWS, WASHERS & NUTS

SRCS Countersunk Snap Rivets

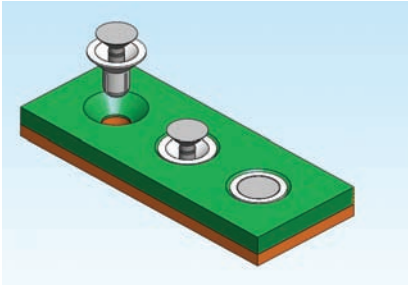

NEW

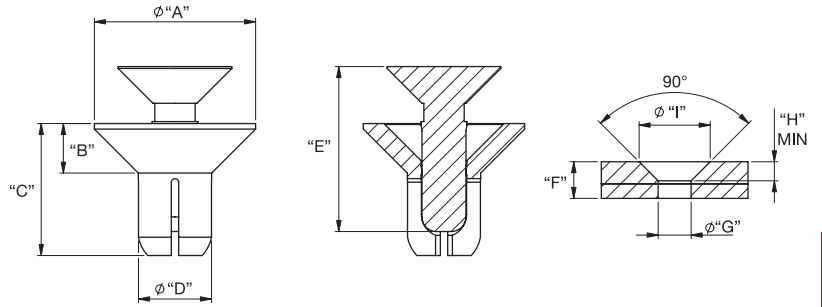

Material: UL94 V2 Nylon 6, RMS-52		Standard Pack: 1,000 per bag								
Part No.		"A"	"B"	"C"	"D"	"E"	Total Holding Thickness "F"	Hole Dia. "G"	"H"	"I"
Color: Black	Color: White	8.8	2.7	6	4	7.1	3.5-4.5	4.1-4.2	2.6	9.4
SRCS-4060B	SRCS-4060W			7.2		9	4.5-5.5			
SRCS-4070B	SRCS-4070W			8		11	5.5-6.5			
SRCS-4080B	SRCS-4080W			9			6.5-7.5			
SRCS-4090B	SRCS-4090W			10	7.5-8.5					
SRCS-4100B	SRCS-4100W	9.8		6.5	5	8.5	3.5-4.5	5.1-5.2		10.4
SRCS-5065B	SRCS-5065W									

Accommodates countersunk hole specification DIN ISO 7721

BPFR Removable Barbed Fastener

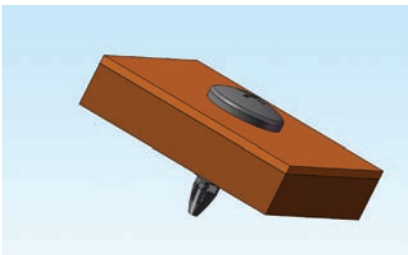

NEW

- Feature
- Phillips head screwdriver required to remove from threaded hole

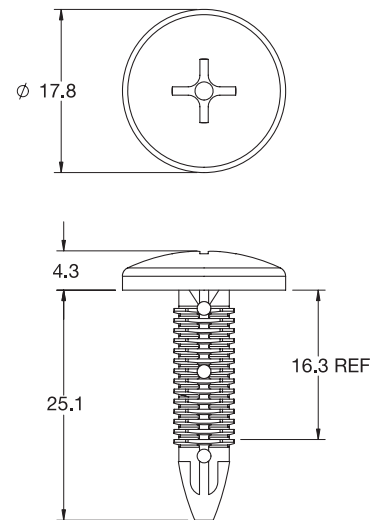

Mat'l: UL94 V0 Nylon 6/6, RMS-19 Color: Black		Standard Pack: 1000 per bag	
Part No.	Threaded Hole	Non-Threaded Hole Dia	Minimum Panel Thickness
BPFR-1	M8	7	6

RRR Removable Rivet

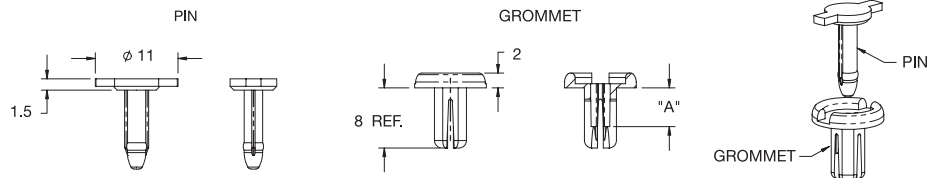
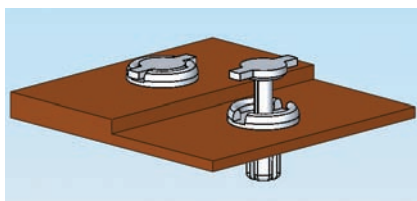

Mat'l: Nylon 66/6, RMS-103 Color: Black		Standard Pack: 1,000 per bag	
Part No.	Hole Size	Panel Thickness	"A" Ref.
RRR-1	4.76-5.28 Dia.	1.5-3.5	3.6
RRR-2	or 4.5 Min. Square	3.5-5.5	4.4

Pin and Grommet are supplied unassembled

RIVETS, SCREWS, WASHERS & NUTS

SR/SRVO Snap Rivets

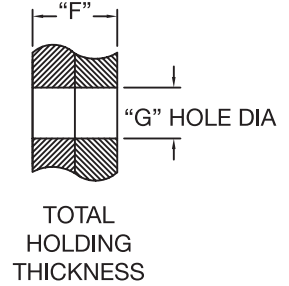
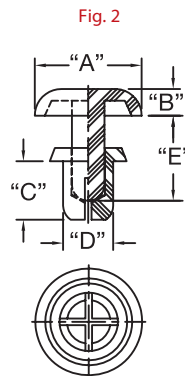
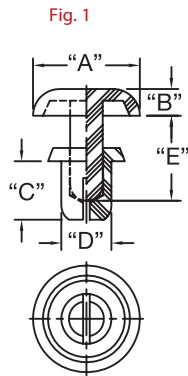
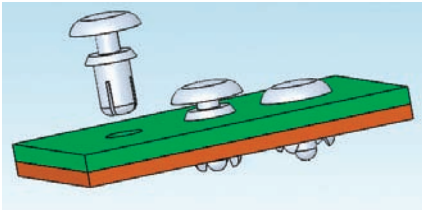

Mat'l: UL94 V2 Nylon 6, RMS-52		Mat'l: UL94 V0 Nylon 66/6, RMS-103		Standard Pack: 1,000 per bag							
Color: Black	Color: White	Color: Black	Hole Dia. "G"	Extraction Force kg Typ.	Total Holding Thickness "F"	"A" Dia.	"B"	"C"	"D" Dia.	"E"	Fig. No.
SR-2024B	SR-2024W	SRVO-2024B	2.1 - 2.2	3	0.6 - 1.2	4.2	1.2	2.4	2	2.8	1
SR-2032B	SR-2032W	SRVO-2032B			1.3 - 2			3.2		3.8	
SR-2040B	SR-2040W	SRVO-2040B			2.1 - 2.8			4		5.5	
SR-2048B	SR-2048W	SRVO-2048B			2.9 - 3.6			4.8		5.5	
SR-2056B	SR-2056W	SRVO-2056B			3.7 - 4.4			5.6		7.2	
SR-2064B	SR-2064W	SRVO-2064B			4.4 - 5			6.4		7.1	
SR-2632B	SR-2632W	SRVO-2632B	2.7 - 2.8	5	1 - 2	5	1.4	3.2	2.6	4.5	
SR-2642B	SR-2642W	SRVO-2642B			2 - 3			4.2		4.5	
SR-2648B	SR-2648W	SRVO-2648B			2.7 - 3.6			4.8		6.1	
SR-2655B	SR-2655W	SRVO-2655B			3.4 - 4.3			5.6		6.1	
SR-2664B	SR-2664W	SRVO-2664B			4.3 - 5.2			6.4		7.8	
SR-2672B	SR-2672W	SRVO-2672B			5.1 - 6			7.2		7.8	
SR-3035B	SR-3035W	SRVO-3035B	3.1 - 3.2	8	1 - 2	6.4	1.6	3.5	3	5.1	
SR-3045B	SR-3045W	SRVO-3045B			2 - 3			4.5		6.1	
SR-3055B	SR-3055W	SRVO-3055B			3 - 4			5.6		6.1	
SR-3065B	SR-3065W	SRVO-3065B			4 - 5			6.5		7.1	
SR-3075B	SR-3075W	SRVO-3075B			5 - 6			7.5		9	
SR-3080B	SR-3080W	SRVO-3080B			5.5 - 6.5			8		9	
SR-3090B	SR-3090W	SRVO-3090B	6.5 - 7.5	9	11						
SR-3100B	SR-3100W	SRVO-3100B	7.5 - 8.5	10	11						
SR-3535B	SR-3535W	SRVO-3535B	3.6 - 3.7	12	1.2 - 2.1	6.4	1.6	3.5	3.5	5.1	2
SR-3545B	SR-3545W	SRVO-3545B			2.1 - 3			4.5		6.1	
SR-3550B	SR-3550W	SRVO-3550B			2.7 - 3.6			5		6.1	
SR-3555B	SR-3555W	SRVO-3555B			3 - 4			5.6		7.1	
SR-3560B	SR-3560W	SRVO-3560B			3.7 - 4.6			6		7.1	
SR-3570B	SR-3570W	SRVO-3570B			4.5 - 5.5			7.2		9	
SR-3580B	SR-3580W	SRVO-3580B	5.5 - 6.5	8	9.1						
SR-4050B	SR-4050W	SRVO-4050B	4.1 - 4.2	20	2.5 - 3.5	8	1.8	5	4	7.1	
SR-4060B	SR-4060W	SRVO-4060B			3.5 - 4.5			6		7.1	
SR-4070B	SR-4070W	SRVO-4070B			4.5 - 5.5			7.2		9	
SR-4080B	SR-4080W	SRVO-4080B			5.5 - 6.5			8		9	
SR-4090B	SR-4090W	SRVO-4090B			6.5 - 7.5			9		11	
SR-4100B	SR-4100W	SRVO-4100B			7.5 - 8.5			10		11	
SR-4120B	SR-4120W	SRVO-4120B	9 - 10.5	12	14						
SR-5045B	SR-5045W	SRVO-5045B	5.1 - 5.2	25	1.5 - 2.5	9	2.2	4.5	5	6.5	
SR-5055B	SR-5055W	SRVO-5055B			2.5 - 3.5			5.6		6.5	
SR-5065B	SR-5065W	SRVO-5065B			3.5 - 4.5			6.5		8.5	
SR-5075B	SR-5075W	SRVO-5075B			4.5 - 5.5			7.5		8.5	
SR-5085B	SR-5085W	SRVO-5085B			5.5 - 6.5			8.5		10.5	
SR-5095B	SR-5095W	SRVO-5095B			6.5 - 7.5			9.5		10.5	
SR-5105B	SR-5105W	SRVO-5105B	7.5 - 8.5	10.5	12						
SR-6060B	SR-6060W	SRVO-6060B	6.1 - 6.2	30	2.5 - 4	12	2.5	6	6	9	
SR-6080B	SR-6080W	SRVO-6080B			3.5 - 5.5			8		10	

Colors: Green (GN), Yellow (YL), Red (RD), Blue (BL), and Grey (GY) are available by special order.

Available by special order; 5,000 piece minimum.

SRHR

Snap Rivet Heat Resistant

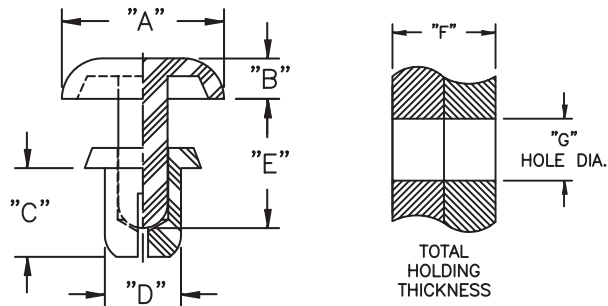
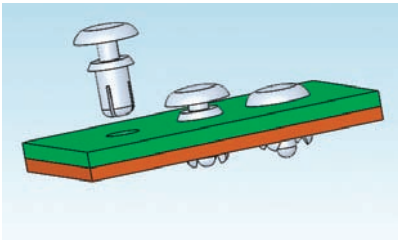

Feature

- Withstands temperatures up to 152° C

Mat'l: UL94 V2 Nylon 4/6, RMS-56 Color: Tan				Standard Pack: 1,000 per bag			
Part No.	Hole Dia. "G"	Total Holding Thickness "F"	"A" Dia.	"B"	"C"	"D" Dia.	"E"
SRHR-3035	3.1 - 3.2	1 - 2	6.4	1.6	3.5	3	5.1
SRHR-3045		2 - 3			4.5		6.1
SRHR-3055		3 - 4			5.6		6.1
SRHR-3065		4 - 5			6.5		7.1
SRHR-3080		5 - 6.5			8		9
SRHR-3535	3.6 - 3.7	1.2 - 2.1	8	1.8	3.5	3.5	5.1
SRHR-3545		2.2 - 3.1			4.5		6.1
SRHR-3555		3 - 4			5.6		7.1
SRHR-4050	4.1 - 4.2	2.5 - 3.5	8	1.8	5	4	7.1
SRHR-4060		3.5 - 4.5			6		7.1
SRHR-4070		4.5 - 5.5			7.2		9
SRHR-4080		5.5 - 6.5			8		9
SRHR-4100		7.5 - 8.5			10		11

SRP Snap Rivet "P" Type

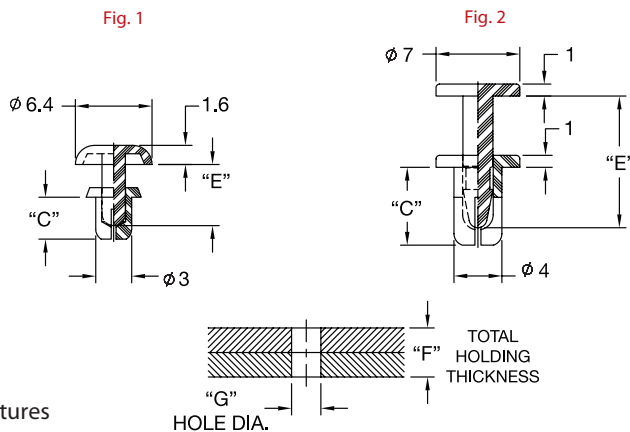

Features

- Withstands temperatures up to 155°C.

Mat'l: UL94 V1 Polysulfone, RMS-51		Color: Black			
Standard Pack: 1,000 per bag					
Part No.	Hole Dia. "G"	Total Holding Thickness "F"	"C"	"E"	Fig.
SRP-3045	3.1 - 3.2	1.5 - 2.5	4.5	6.1	1
SRP-3055		2.5 - 3.5	5.5		
SRP-4065	4 - 4.2	3.5 - 4.5	6.5	11	2

PPR-10 Push Rivet

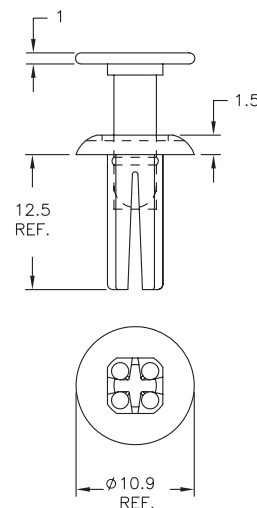

Material: UL94 V2 Nylon 6, RMS-120 Color: Natural		
Standard Pack: 100 per bag		
Part No.	Total Holding Thickness	Mounting Hole Options
PPR-10	3.56-5.08	6.4 Round Hole
		5.6 Square Hole

RIVETS, SCREWS, WASHERS & NUTS

TR
Tough Snap Rivets

NEW

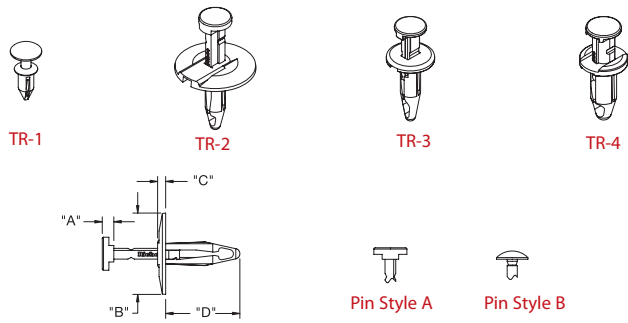
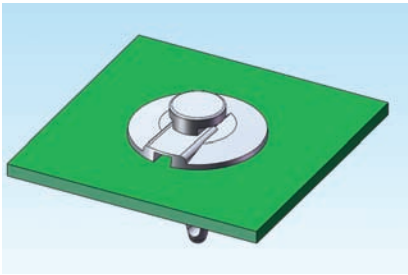

Material: UL94 HB Impact Modified Nylon 6/6, RMS-73							Color: Black		
Standard Pack: 1,000 per bag									
Part Number	Hole Diameter	Panel Thickness	"A"	"B" Dia.	"C"	"D"	No. of Legs	Pin Head Style	
TR-1	4.9 - 5.2	1.5 - 4.6	2.5	7.2	1.1	11.3	3	B	
TR-2	6.3 - 7	2.5 - 8.9	3.6	25	2.5	22.8	2	A	
TR-3	6.4 - 7	2.5 - 8	2.8	14.9	2				
TR-4	8 - 8.3	3 - 8	2.3			2.7	21.1		

TRM
Mini Tough Snap Rivets

NEW

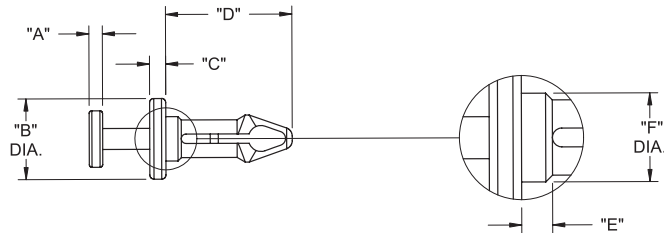
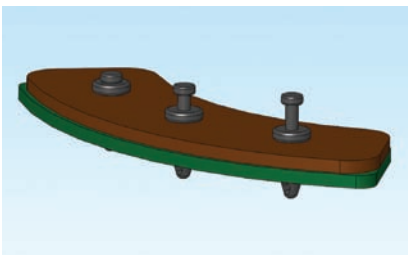

Material: UL94 V2 Heat Stabilized Nylon 6/6, RMS-47							Color: Black		
Standard Pack: 1,000 per bag									
Part Number	Hole Diameter	Panel Thickness	"A"	"B" Dia.	"C"	"D"	"E" Ref.	"F" Ref.	
TRM-1	2.5 - 2.6	4.1 - 4.6	1	4.8	1.5	8.8	-	-	
TRM-2	2.7 - 2.8	2 - 2.7	1.3	5.5		7.6			
TRM-3	3.1 - 3.3	2.7 - 3.3				8.1			
TRM-4		3.3 - 3.9				7.6			
TRM-5		3.9 - 4.6				9.4			
TRM-6	6.1 - 6.7	11.6							
TRM-7	3.7 - 3.9	6.7 - 7.4	7.6	11.9		1.1	4.2		

RFL
Folding Leg Rivets

NEW

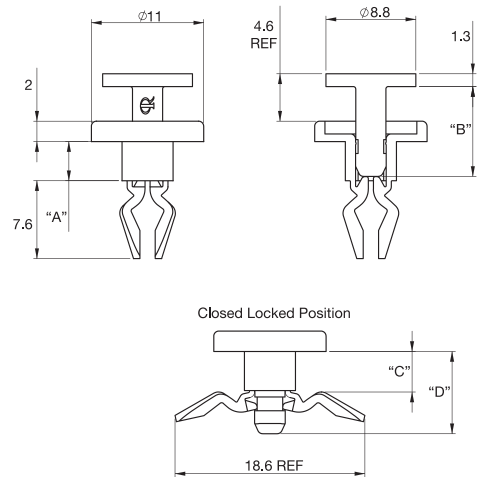
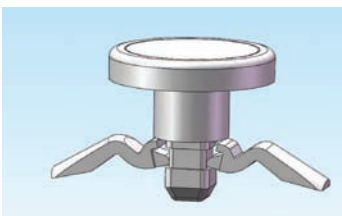

Part No		Material: UL94 V2 Nylon 6/6, RMS-01						
		Standard Pack: 1,000 per bag						
Color: Natural	Color: Black	"A"	"B"	"C"	"D"	Total Panel Thickness	Mounting Hole Dia.	
RFL-1	RFL-1BK	3	8.1	2.7	7.4	2.85 - 3.85	5.5	
RFL-2	RFL-2BK	3.7	8.8	3.3	8.1	3.55 - 4.55		

RIVETS, SCREWS, WASHERS & NUTS

USR

Unscrewing Snap Rivet

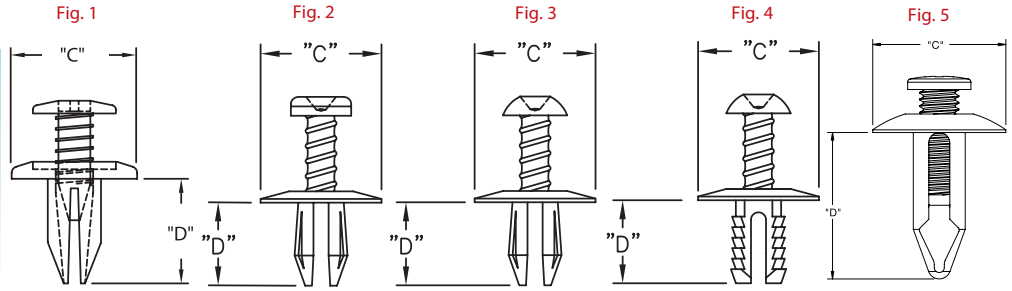
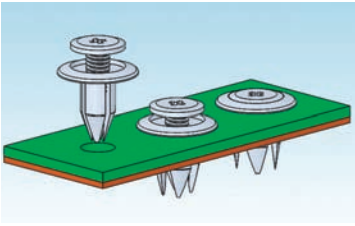

Feature

- Phillips head screwdriver required to remove from hole

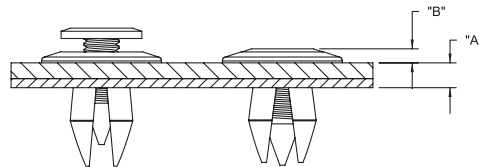

Color: Black								
Part No.	Hole Ø	"A" Total Holding Thickness	"B"	"C" Ø	"D"	Fig.	Material	Standard Pack
USR-64125	6.4	3.2 - 4.4	3	15.1	12.7	1	UL94 V2 Nylon 6, RMS-52	500 per bag
USR-1131	5	4 - 7	3.9	12	11	2	UL94 V2 Nylon 6/6, RMS-115	1000 per bag
USR-1132	6	1.5 - 6		16		3		
USR-1133	8	3 - 10	4	20	14	4		
NEW USR-1	8	7 - 8	3.6	20	22	5	Grommet: UL94 V2 Nylon 6, RMS-52; Screw: UL94 HB Acetal, RMS-14	

PPR/PPR-T

Push Rivet/ Push Rivet Tool

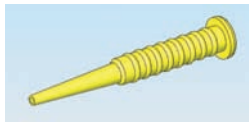
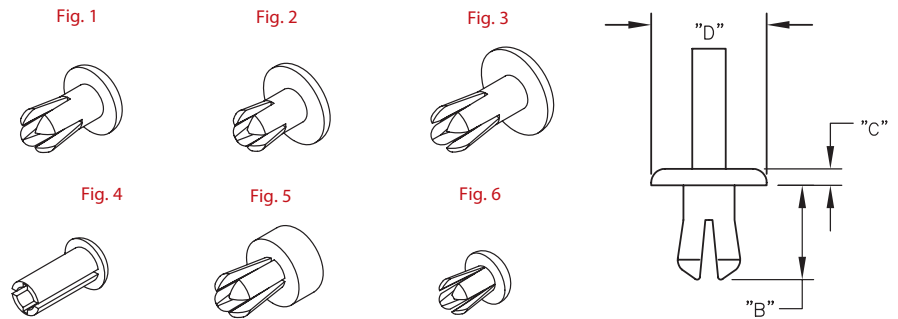
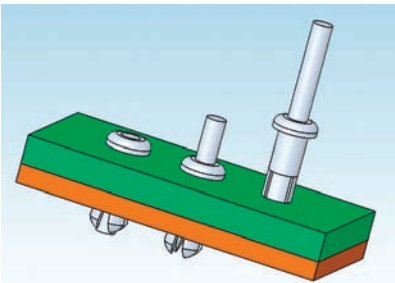

Material: UL94 V2 Nylon 6/6, RMS-01				Standard Pack: 1000 per bag				
Part No.		Hole Ø	Total Holding Thickness	"B"	"C"	"D" Ø	Installation Tool	Fig.
Color: Natural	Color: Black							
PPR-5	PPR-5B	4.8	1 - 9.5	10.7	1.6	7.1	PPR-T1	4
PPR-93-7	PPR-93-7B	5	1.5 - 5	7.4	2			6
PPR-9	PPR-9B	6.4	1.5 - 6.4	9.3	4.7	11.1	-	5
PPR-1	PPR-1B	5.5	2.4 - 4	11.4	2	9.4	PPR-T1	1
-	PPR-93-14B	5	3 - 7	11		9.7		6
PPR-2	PPR-2B	4.8	4 - 7.1	9.7		1.5		10.9
PPR-4	PPR-4B	6.4	7.1 - 12.7	15.8	2	11.9	-	3

Available by special order only

RIVETS, SCREWS, WASHERS & NUTS

PPR Push Rivet Blunt

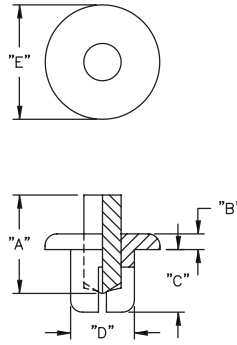
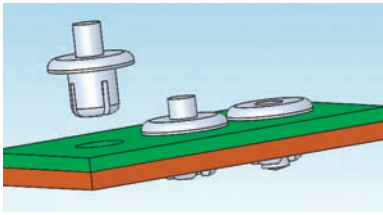

Standard Pack: 1000 per bag						Color: Black		
Part No.	Ø Hole	Total Holding Thickness	"A"	"B"	"C"	Ø "D"	Ø "E"	Material
PPR-3055B	3.1	3 - 4	8.9	2	5.6	3	5.8	UL94 V1 Nylon 6, RMS-52
PPR-4050B	4.1	2.5 - 3.5	9.2	2.2	5	4	8	
PPR-4850B	4.8	1.2 - 3	10.4	3.3	5.1	4.8	9.9	
PPR-5060B	5.1	3 - 4	9.4	2.8	6.1	5	9.4	
PPR-5070B		4 - 5	11.4		7.1			
PPR-5080B	5 - 6				8.1			
PPR-6060B	6.1	2.5 - 4	9.4	1.5	6.1	6	10.9	Polyethylene, RMS-142

Available in white color by special order. To order, change the B at the end of the part number to W.

DF Drive Fastener

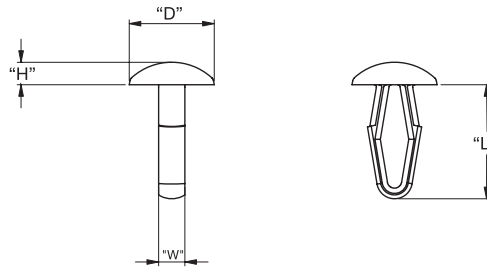
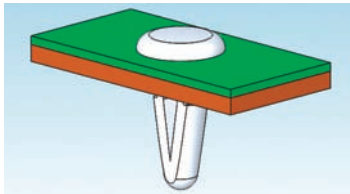

Color: Natural				Standard Pack: 1000 per bag			
Mat'l: UL94 HB Acetal, RMS-14A	Mat'l: UL94 V0 Nylon 6/6, RMS-19	Hole Ø	Total Holding Thickness	"D" Ø	"H"	"L" Ref.	"W" Ref.
DF-137-010	DFVO-137-010	3.2	1 - 4.5	8	1.5	13	2.7
DF-137-020	DFVO-137-020	3.9	1 - 5	9	1.6	14	2.9
DF-137-030	DFVO-137-030	4.7	1 - 5.5	10	1.7	15	3.4
DF-137-031	DFVO-137-031			11	2.9		
DF-137-040	DFVO-137-040	6.4	1.5 - 6.5	12	2	17	3.9
DF-137-050	DFVO-137-050	7.8	1.5 - 7	14	2.2	19	4.2
DF-137-060	DFVO-137-060	5.5	6 - 9	12	2	17.5	3.8

MMB Mini Mounting Button

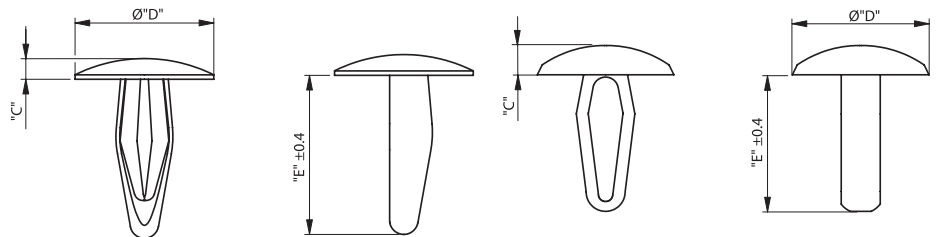
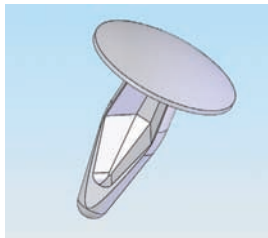

Material: UL94 V2 Nylon 6/6, RMS-01*							
Standard Pack: 1,000 per bag							
Part No.		Mounting Hole Ø	Total Holding Thickness	"C"	"D" Ø	"E"	Fig.
Color: Natural	Color: Black						
MMB-125-01	MMB-125-01BK	3.10-3.22	2-2.5	1	6.9	8.4	1
MMB-136-01	MMB-136-01BK	3.32-3.58	2.9-4	1.7	10.3	11.1	
MMB-187-01	MMB-187-01BK	4.61-4.88	2.5-4	2.2	12.7	10.9	
MMB-210-01	MMB-210-01BK	5-5.4	2.5-4	3	14	14	2
MMB-250-01	MMB-250-01BK	6.27-6.42	2.5-5.6	2.2	12.7	16.3	1

*Available in UL94 V0 material by special order. To order, replace -01 with -19.

RIVETS, SCREWS, WASHERS & NUTS

MB
Mounting Button

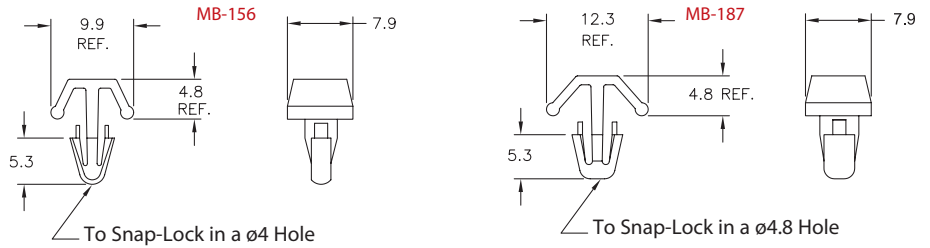
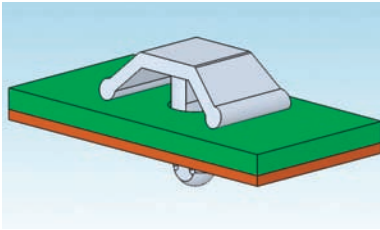

Material: UL94 V2 Nylon 6/6, RMS-01* Color: Natural		
Standard Pack: 1,000 per bag		
Part No.	Total Holding Thickness	
MB-1-156	MB-1-187	0.8 - 2.4
MB-3-156	MB-3-187	2.4 - 4
MB-5-156	MB-5-187	4 - 5.6
MB-7-156	MB-7-187	5.6 - 7.1
MB-9-156	MB-9-187	7.1 - 8.7
MB-11-156	MB-11-187	8.7 - 10.3

*Available in UL94 V0 material by special order. To order, add -19 to the end of the part number.

BHF
Blind Hole Fasteners

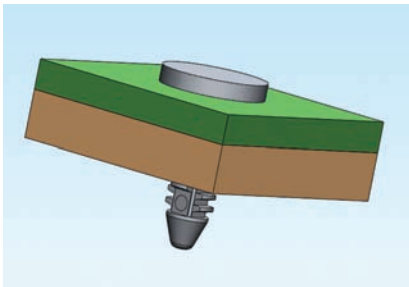

NEW

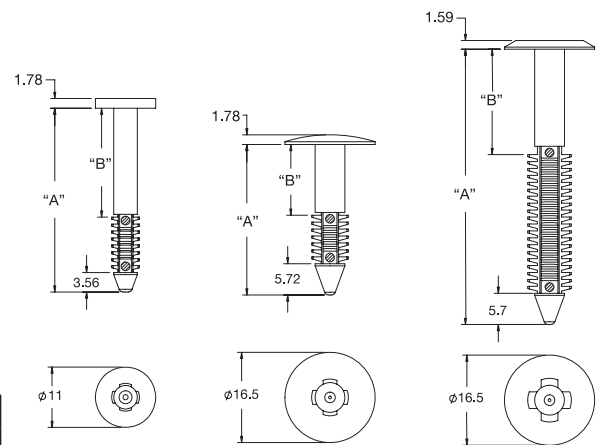

Material: UL94 V2 Nylon 6/6, RMS-01*				Color: Black	
Standard Pack: 1,000 per bag					
Part No.	"A"	"B" Ref	Suggested Total Board Thickness	Hole Diameter	Fig.
BHF-1	14.2	0.5	0.9 - 9.8	4.75	1
BHF-2	16.5	2.8	3.2 - 12.1		
BHF-3	24.1	10.4	10.8 - 19.7		
BHF-4	33.7	19.9	20.3 - 29.2	6.35	2
BHF-5	15.1	0.5	0.9 - 8.5		
BHF-6	16.6	2	2.4 - 10		
BHF-7	22.5	7.9	8.3 - 15.9		
BHF-8	27.6	12.9	13.3 - 21	7.14	3
BHF-9	18.7	1.5	1.9 - 12.1		
BHF-10	28.8	11.7	12.2 - 22.2		
BHF-11	32.6	1.5	1.9 - 26		
BHF-12	37.7	6.6	7 - 31.1		
BHF-13	45.3	14.2	14.6 - 38.7	7.14	3
BHF-14	50.8	19.3	19.7 - 43.8		

*Available in UL94 V0 material by special order. To order, add -V0 to the end of the part number

Natural color available by special order. To order, add NT to the end of the part number

PFP-7-01
Press Fit Pin

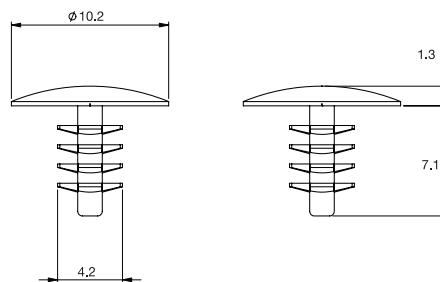
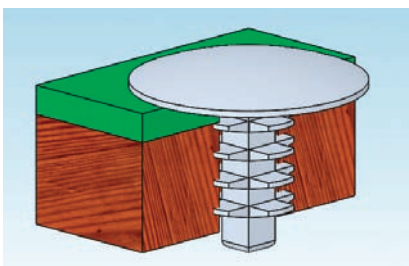

PFP	Standard Pack: 1,000 per bag	
Mat'l: UL94 V2 Nylon 6/6, RMS-01* Color: Natural	Hole Diameter	Panel Thickness
PFP-7-01	3.5 ± .05	6.35 Min.

*Available in UL94 V0 material by special order. To order, change -01 to -19

RIVETS, SCREWS, WASHERS & NUTS

PL
Pawl Lock

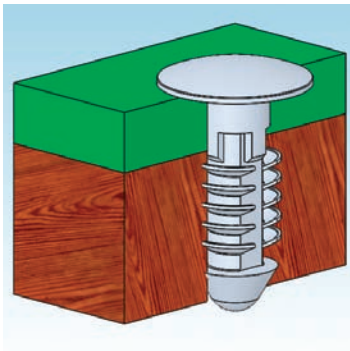

Material: Nylon 6/6, RMS-01 Color: Natural				Standard Pack: 1000 per bag			
Part No.	"A"	"B"	"C"	"D"	"E"	Hole Size	Fig.
PL-250-10-01	15.4F	3.2	2	12.7	4.1	6.35	1
PL-250-12-01	19.1	6.7	1.8				
PL-250-20-01	25	2.1		9	5	5.5	2

Fig 1

Fig 2

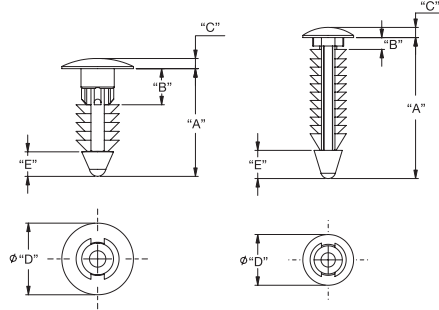

MPL
Mini Pawl Locks

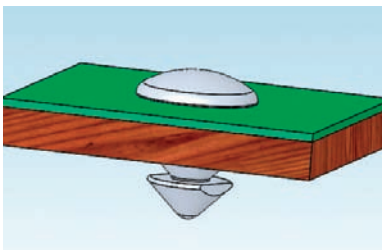

MPL-3.2M-01

MPL-3.2M/3.5M-01

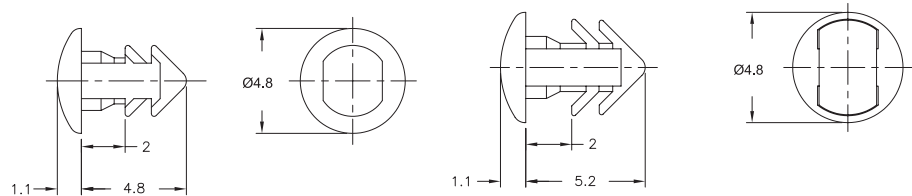

Mat'l: UL94 V2 Nylon 6/6, RMS-01* Color: Natural		
Standard Pack: 1000 per bag		
Part No.	Hole Ø	Total Holding Thickness
MPL-3.2M-01	3.2	1.85 Max
MPL-3.2M/3.5M-01	3.2 - 3.5	

*Parts are available in UL94 V0 material by special order only. To order, replace -01 with -19.

BPF
Barbed Push Fastener

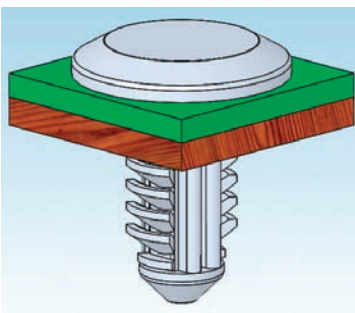

Fig. 1

Fig. 2

Fig. 3

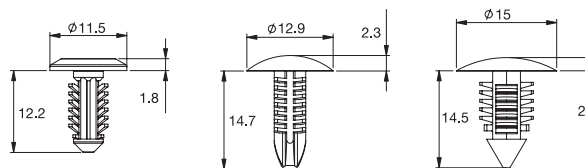
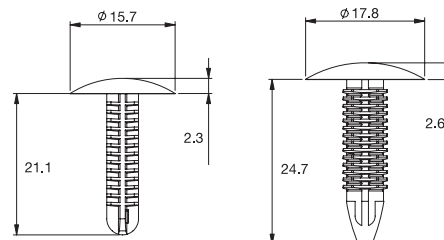

Fig. 4

Fig. 5



Color: Black		Standard Pack: 1000 per bag		
Part No.	Material	Hole Ø	Total Holding Thickness	Fig
BPF-A414	UL94 V0, RMS-19	4.7	0.8 - 3	1
BPF-F4410	UL94 V2, RMS-01	5	1.5 - 7.5	2
BPF-F2495	UL94 V0, RMS-19	7	3.2 - 6	3
BPF-F3T31		5	2 - 10	4
BPF-F1G12		7	2 - 15	5

RIVETS, SCREWS, WASHERS & NUTS

RBF Barbed Fasteners

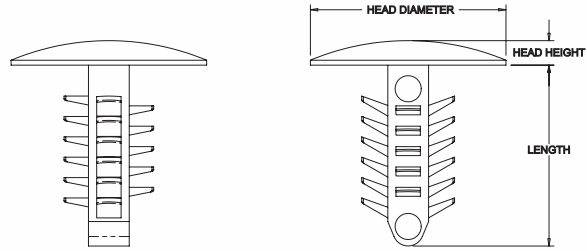
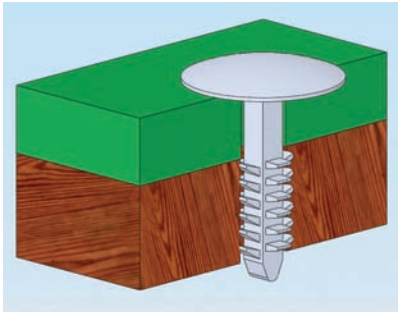

Mat'l: UL94 V2 Nylon 6/6, RMS-01* Color: Black						
Standard Pack: 1,000 per bag						
Part No.	Hole Diameter	Head Diameter	Suggested Total Board Thickness	Head Height	Length	
RBF-4-8.6-8	4	8	2.1 - 4.3	1	8.6	
RBF-4-11.1-8			2.1 - 7.2		11.1	
RBF-4-15-8			5.7 - 10.7		15	
RBF-4-8.6-12		12	12	2.1 - 4.3	1.5	8.6
RBF-4-11.1-12				2.1 - 7.2		11.1
RBF-4-15-12				5.7 - 10.7		15
RBF-4-8.6-16		16	16	2.1 - 4.3	2	8.6
RBF-4-11.1-16				2.1 - 7.2		11.1
RBF-4-15-16				5.7 - 10.7		15
RBF-4.8-8.6-8	4.76	8	2.1 - 4.3	1	8.6	
RBF-4.8-11.1-8			2.1 - 7.2		11.1	
RBF-4.8-15-8			5.7 - 10.7		15	
RBF-4.8-8.6-12		12	12	2.1 - 4.3	1.5	8.6
RBF-4.8-11.1-12				2.1 - 7.2		11.1
RBF-4.8-15-12				5.7 - 10.7		15
RBF-4.8-8.6-16		16	16	2.1 - 4.3	2	8.6
RBF-4.8-11.1-16				2.1 - 7.2		11.1
RBF-4.8-15-16				5.7 - 10.7		15
RBF-6.4-8.6-8	6.35	8	2.1 - 4.3	1	8.6	
RBF-6.4-11.1-8			2.1 - 7.2		11.1	
RBF-6.4-15-8			5.7 - 10.7		15	
RBF-6.4-8.6-12		12	12	2.1 - 4.3	1.5	8.6
RBF-6.4-11.1-12				2.1 - 7.2		11.1
RBF-6.4-15-12				5.7 - 10.7		15
RBF-6.4-8.6-16		16	16	2.1 - 4.3	2	8.6
RBF-6.4-11.1-16				2.1 - 7.2		11.1
RBF-6.4-15-16				5.7 - 10.7		15
RBF-7.1-11.1-8	7.14	8	2.1 - 7.2	1	11.1	
RBF-7.1-15-8			3.8 - 10.7		15	
RBF-7.1-19-8			6.9 - 14.2		19	
RBF-7.1-11.1-12		12	12	2.1 - 7.2	1.5	11.1
RBF-7.1-15-12				3.8 - 10.7		15
RBF-7.1-19-12				6.9 - 14.2		19
RBF-7.1-11.1-16		16	16	2.1 - 7.2	2	11.1
RBF-7.1-15-16				3.8 - 10.7		15
RBF-7.1-19-16				6.9 - 14.2		19

*Available in UL94 V0 material by special order. To order, add -V0 to the end of the part number.

Natural color available by special order. To order, add NT to the end of the part number

MBRR/MBRP Mini Barbed Rivet

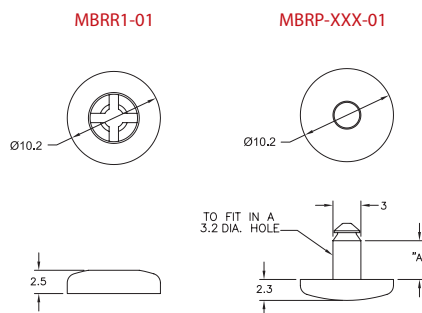
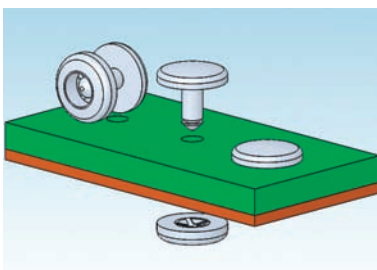

Material: UL94 V2 Nylon 6/6, RMS-01 Color: Natural		
Standard Pack: 1,000 per bag		
Part No.	"A"	Panel Thickness Max.
MBRP1-030-01	1.60	0.76
MBRP1-062-01	2.41	1.57
MBRP1-100-01	3.38	2.54
MBRP1-125-01	4.01	3.18
MBRP1-187-01	5.59	4.75
MBRP1-250-01	7.19	6.35
MBRR1-01	-	-

Female part is sold separately and is common to all sizes in the MBRP series. To order, use part number MBRR1-01

RIVETS, SCREWS, WASHERS & NUTS

BR
Barbed Rivet

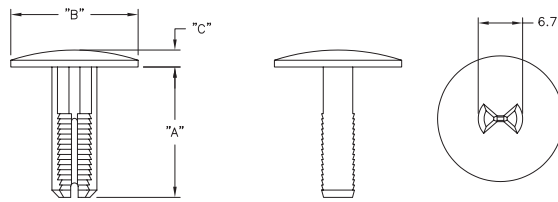
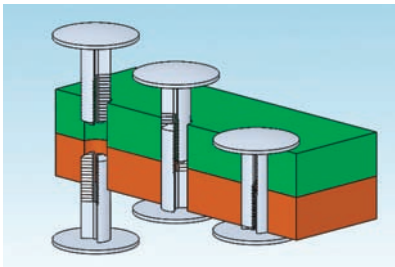

Material: UL94 V2 Nylon 6/6, RMS-01* Color: Natural					
Standard Pack: 1,000 per bag (500 sets per bag)					
Part No.	"A" Ref.	"B" Dia.	"C"	Total Holding Thickness	Hole Diameter
BR1-226-01	5.7	19.1	2.4	6 - 7.5	7.1
BR1-344-01	8.7			8.8 - 12.8	
BR1-488-01	12.4			12.7 - 20.6	
BR1-768-01	19.5			19.8 - 34.9	
BR2-226-01	5.7	10.2	1.6	6 - 7.5	
BR2-344-01	8.7			8.8 - 12.8	
BR2-488-01	12.4			12.7 - 20.6	
BR2-768-01	19.5			19.8 - 34.9	

*Parts are available in UL94 V0 material by special order only. To order, replace -01 with -19.

HSR-1
Heat Sink Spring Mount Rivet

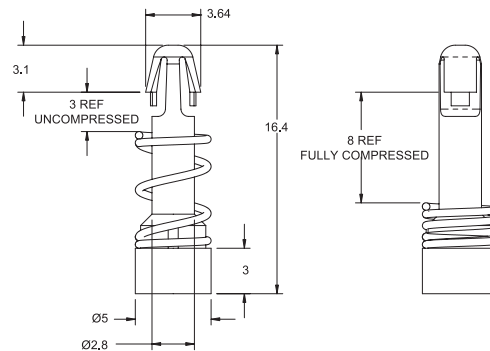
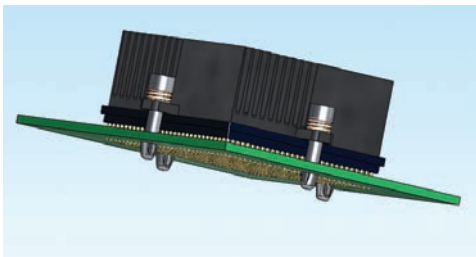

Rivet Mat'l: Nylon 6/6, RMS-47 Color: Natural		
Spring Mat'l: Steel, RMS-326 Chrome Plated RMS-355		
Standard Pack: 1,000 per bag		
Part No.	Heat Sink Hole	Chassis Hole
HSR-1	Inserts through a 3.18 - 4 Hole	Snap-lock into a 3±0.08 Hole

SLPA
Snap Lock Pin with Arrowhead

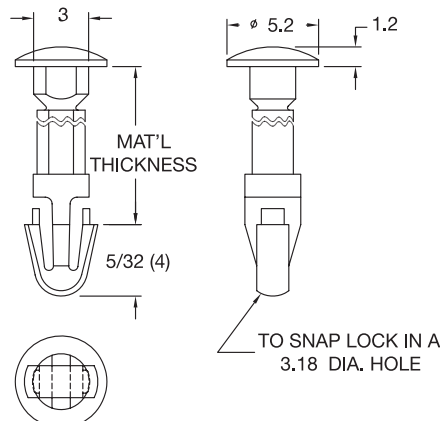
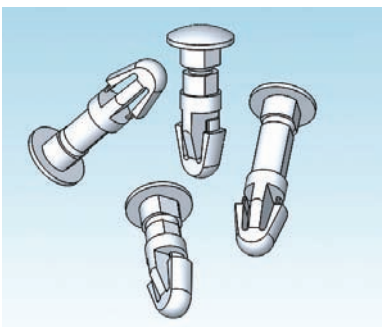

Material: Nylon 6/6, RMS-01* Color: Natural	Standard Pack: 1,000 per bag
	Material Thickness Maximum
SLPA125-187-01	4.7
SLPA125-250-01	6.4
SLPA125-312-01	7.9
SLPA125-375-01	9.5
SLPA125-500-01	12.7
SLPA125-625-01	15.9
SLPA125-750-01	19.1

*Available in UL94 V0 material by special order. To order, replace -01 with -19.

SLP Snap Lock Pin

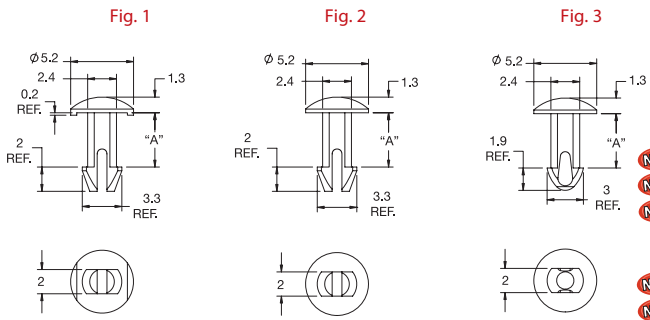

Material: Nylon 6/6, RMS-01* Color: Natural			Standard Pack: 1,000 per bag	
Fig. 1	Fig. 2	Fig. 3	"A"	Hole Dia
SLP100-177-01	SLP-1-100-177-01	SLP-2-100-177-01	4.5	2.5±0.05
NEW SLP100-221-01	NEW SLP-1-100-221-01	NEW SLP-2-100-221-01	5.6	
NEW SLP100-236-01	NEW SLP-1-100-236-01	NEW SLP-2-100-236-01	6	
NEW SLP100-245-01	NEW SLP-1-100-245-01	NEW SLP-2-100-245-01	6.2	
SLP100-307-01	SLP-1-100-307-01	SLP-2-100-307-01	7.8	
SLP100-316-01	SLP-1-100-316-01	SLP-2-100-316-01	8	
NEW SLP100-330-01	NEW SLP-1-100-330-01	NEW SLP-2-100-330-01	8.4	
NEW SLP100-413-01	NEW SLP-1-100-413-01	NEW SLP-2-100-413-01	10.5	
SLP100-638-01	SLP-1-100-638-01	SLP-2-100-638-01	16.2	

*Available in UL94 V0 material, RMS-19 by special order. To order, replace -01 with -19.

SLP125 Snap Lock Pin

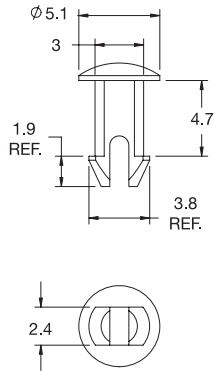
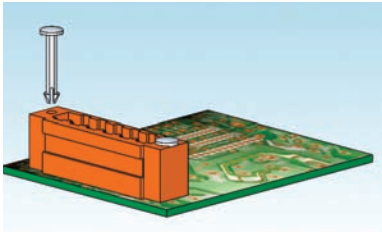

Material: UL94 V2 Nylon 6/6, RMS-01* Color: Natural	
Standard Pack: 1,000 per bag	
Part No.	Hole Dia.
SLP125-187-01	3.18

*Available in UL94 V0 material, RMS-19 by special order. To order, replace -01 with -19.

SEI Sheet Edge Insert

NEW

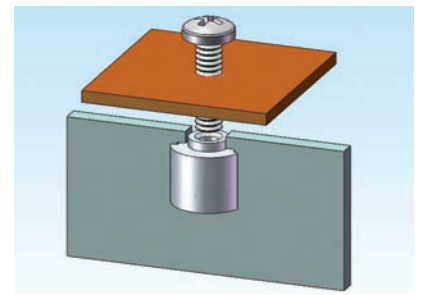
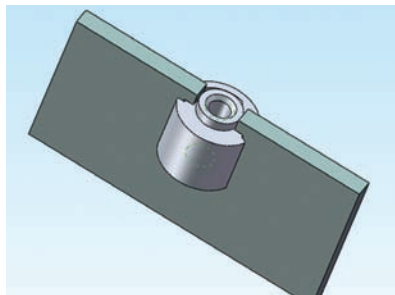
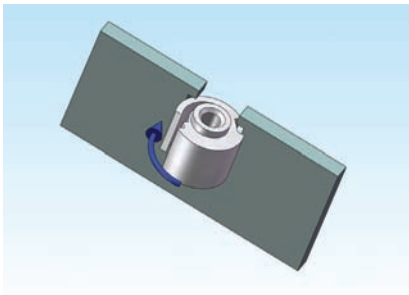

Mounting Hole 1 Mounting Hole 2

Material: UL94 V2 Nylon 6/6, RMS-01 Color: Black						
Standard Pack: 1,000 per bag						
Part No.	"A" Dia.	"B" Dia.	"C"	Thread Type	Panel Thickness	Mounting Hole
SEI-1	9.9	5.3	7.6	#6-32 UNC	1.27 - 2.41	1
SEI-2				M4	1.27 - 2.3	
SEI-3				M3	1.27 - 2.41	
SEI-4	10.9	6.3	8.6	M5	1.27 - 2.41	2
SEI-5				M6		

Screwdriver required for screw installation

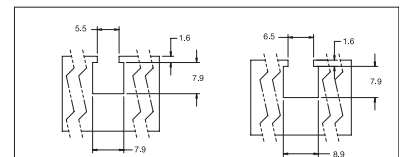
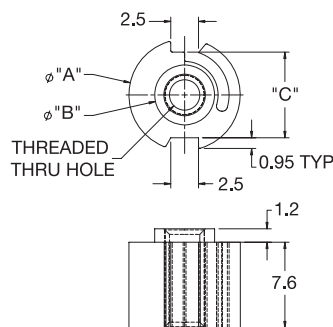

RIVETS, SCREWS, WASHERS & NUTS

SC
Screw Cap

NEW

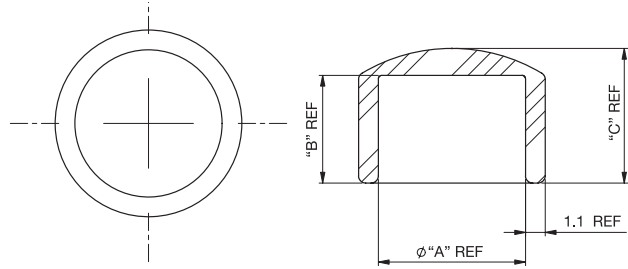

Material: Silicone Rubber, 50 Shore A, RMS-368 Color: Black				
Standard pack: 1,000 per bag				
Part No.	Recommended Button Head Screw Size	"A"	"B"	"C"
SC1-M4	#8, M4	6.7	5	6.5
SC1-M5	1/4, M5	8.2	6	7.5
SC1-M6	5/16, M6	9.7	7	8.5
Other colors available by special order				

NSS/NSP
Slotted and Phillips
Pan Head Screws

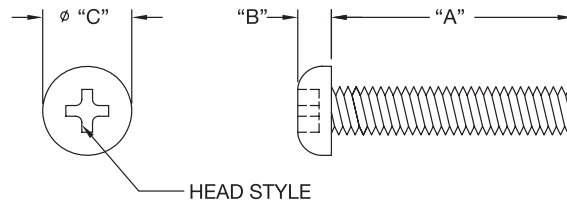
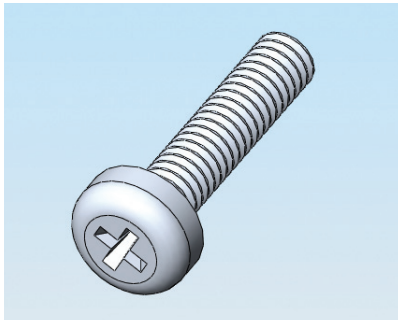

Mating Richco Hex Nuts		
Part#	Thread	Part#
NSS/NSP-4	#4-40	HN#4-40-01
NSS/NSP-6	#6-32	HN#6-32-01
NSS/NSP-8	#8-32	HN#8-32-01
See page 65 for HN series		

Material: UL94 V2 Nylon 6/6, RMS-01 Color: Natural				
Standard Pack: 1,000 per bag				
Part No.	"B"	Thread	"C"	Head Style
NSS-4-#-01	1.8	#4-40	5.3	Slotted, Pan
NSS-6-#-01		#6-32	6.9	
NSS-8-#-01		#8-32	8.1	
NSP-4-#-01	2.3	#4-40	5.3	Phillips, Pan
NSP-6-#-01		#6-32	6.6	
NSP-8-#-01		#8-32	8.1	
Parts available by special order only. 5,000 piece minimum				

#	"A"
-2-	3.2
-3-	4.8
-4-	6.4
-5-	7.9
-6-	9.5
-7-	11.1
-8-	12.7
-10-	15.9
-12-	19.1
-14-	22.2
-16-	25.4

NMS
Nylon Metric Screw

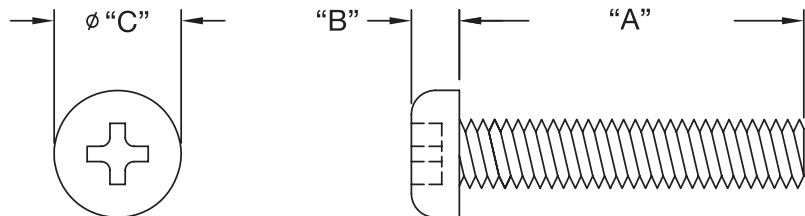
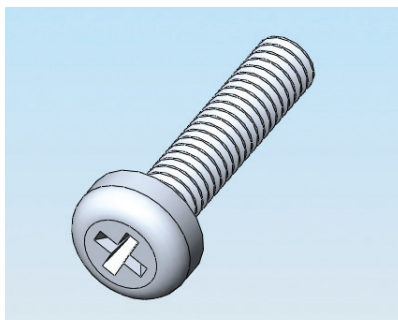

Material: UL94 V2 Nylon 6/6, RMS-01			Color: Natural	
Standard Pack: 1,000 per bag				
Part No.	"A"	"B"	Thread	"C"
NMS-306	6.4	2.5	M3	5.7
NMS-308	8			
NMS-310	10			
NMS-312	12.1			
NMS-408	8	2.8	M4	7.4

RIVETS, SCREWS, WASHERS & NUTS

NSE-1207

Slotted Cheese Head Screw



To DIN EN 1207

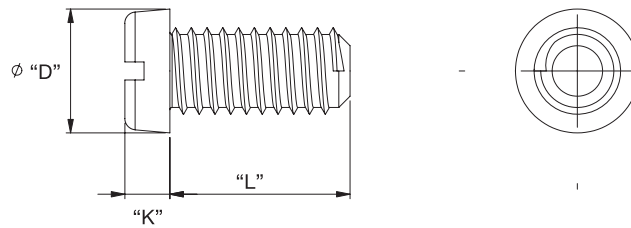

NSE-1207		Standard Pack: 1000 per bag													
Mat'l: Nylon 6/6, RMS-179 Color: Natural	Thread	"L" Screw Length												"D"	"K"
NSE-1207-M2-L	M2	4	5	6	8	10	12	16	20	25	-	-	-	3.8	1.4
NSE-1207-M2.5-L	M2.5	-	-	6	8	10	12	15	20	25	-	-	-	4.5	1.8
NSE-1207-M3-L	M3	4	5	6	8	10	12	16	20	25	30	-	-	5.5	2
NSE-1207-M4-L	M4	-	-	6	8	10	12	16	20	25	30	40	-	7	2.6
NSE-1207-M5-L	M5	-	-	6	8	10	12	16	20	25	30	40	-	8.5	3.3
NSE-1207-M6-L	M6	-	-	6	8	10	12	16	20	25	30	40	50	10	3.9

Parts available by special order only.

NSE-1580

Slotted Pan Head Screw



To DIN EN 1580

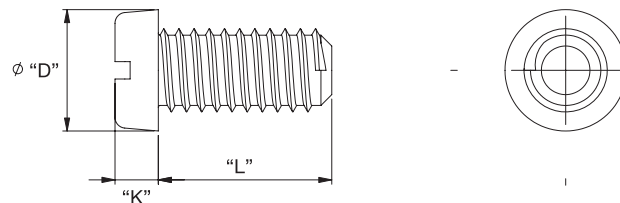

Material: UL94 HB Nylon 6/6, RMS-179											Color: Natural				
Standard Pack: 1000 per bag															
Part No.	Thread	"L" Screw Length												"D"	"K"
NSE-1580-M2-L	M2	4	5	6	8	10	12	16	20	25	-	-	-	4	1.3
NSE-1580-M2.5-L	M2.5	-	-	6	8	10	12	15	20	25	-	-	-	5	1.5
NSE-1580-M3-L	M3	4	5	6	8	10	12	16	20	25	30	-	-	5.6	1.8
NSE-1580-M4-L	M4	-	-	6	8	10	12	16	20	25	30	40	-	8	2.4
NSE-1580-M5-L	M5	-	-	6	8	10	12	16	20	25	30	40	-	9.5	3
NSE-1580-M6-L	M6	-	5	6	8	10	12	16	20	25	30	40	50	12	3.6

Parts available by special order only.

NSE-2009

Countersunk Head Screw

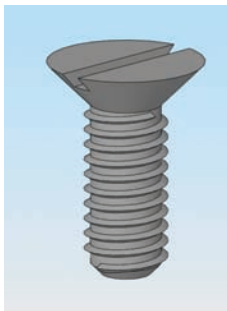

To DIN EN 2009

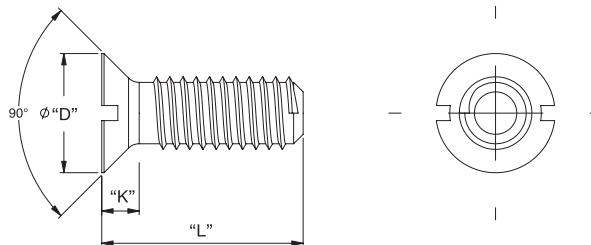

NSE-2009		Standard Pack: 1000 per bag																		
Mat'l: Nylon 6/6, RMS-179 Color: Natural	Thread	"L" Screw Length												"D"	"K"					
NSE-2009-M3-L	M3	5	6	-	8	-	-	16	-	20	25	30	-	-	42	-	-	5.5	1.65	
NSE-2009-M4-L	M4	-	6	-	8	10	12	15	16	-	20	25	30	35	-	-	-	8.4	2.7	
NSE-2009-M5-L	M5	-	-	7	8	10	12	15	16	18	20	25	30	35	40	-	-	9.3	2.7	
NSE-2009-M6-L	M6	-	-	-	8	10	12	-	16	-	20	25	30	-	40	-	50	60	11.3	3.3

Parts available by special order only.

RIVETS, SCREWS, WASHERS & NUTS

NSE-2010

Slotted Countersunk
Oval Head Screw

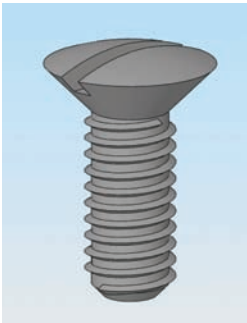

To DIN EN 2010

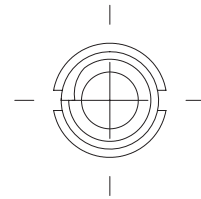
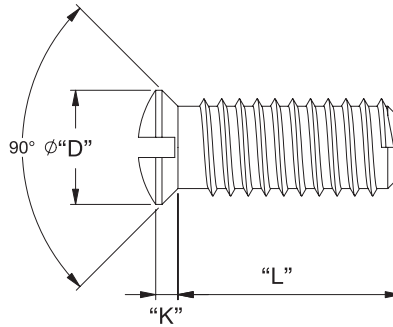

NSE-2010		Standard Pack: 1000 per bag															
Mat'l: Nylon 6/6, RMS-179 Color: Natural	Thread	"L" Screw Length														"D"	"K"
NSE-2010-M3-L	M3	5	6	8	10	12	-	16	-	20	-	25	-	-	-	5.5	1.65
NSE-2010-M4-L	M4	-	6	8	10	12	15	-	-	20	-	25	30	-	-	8.4	2.7
NSE-2010-M5-L	M5	-	-	-	10	12	15	-	18	20	-	25	30	-	-	9.3	2.7
NSE-2010-M6-L	M6	-	-	8	10	12	15	-	-	20	22	25	30	40	50	11.3	3.3

Parts available by special order only.

NSE-34812

Cross Recessed
Oval Head Screw

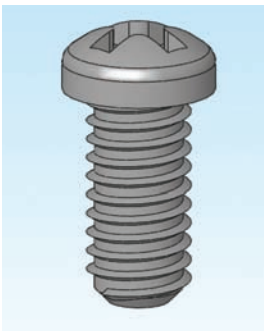

To DIN EN 34812

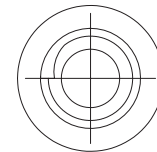
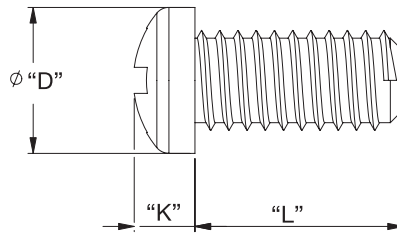

NSE-34812		Standard Pack: 1000 per bag															
Mat'l: Nylon 6/6, RMS-179 Color: Natural	Thread	"L" Screw Length														"D"	"K"
NSE-34812-M3-L	M3	4	5	6	8	10	12	16	20	25	-	-	-	-	6	2.4	
NSE34812-M4-L	M4	-	-	6	8	10	12	16	20	25	30	40	-	-	8	3.1	
NSE-34812-M5-L	M5	-	-	6	8	10	12	16	20	25	30	40	50	-	9.5	3.7	
NSE-34812-M6-L	M6	-	-	-	8	10	12	16	20	25	30	40	50	60	12	4.6	

Parts available by special order only.

NWE

Nylon Washer

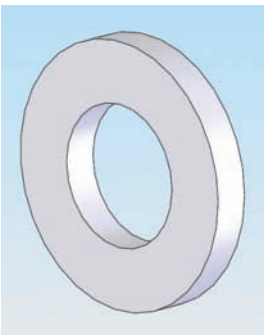

To DIN EN 34815

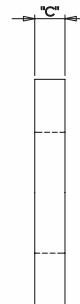
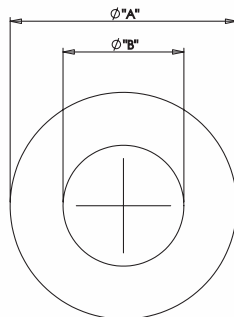

NWE-34815		Standard Pack: 1000 per bag			
Mat'l: Nylon 6/6, RMS-174 Color: Natural	Thread	$\phi "A"$	$\phi "B"$	"C"	
NWE-34815-M2.5	M2.5	6.5	2.7	0.5	
NWE-34815-M3	M3	7	3.2	0.5	
NWE-34815-M4	M4	9	4.3	0.8	
NWE-34815-M5	M5	10	5.3	1	
NWE-34815-M6	M6	12	6.4	1.6	

Parts available by special order only.

RIVETS, SCREWS, WASHERS & NUTS

HN
Hex Nut

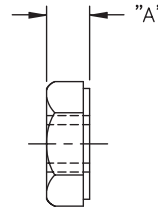
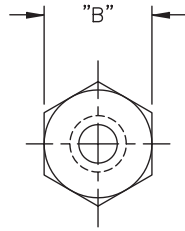
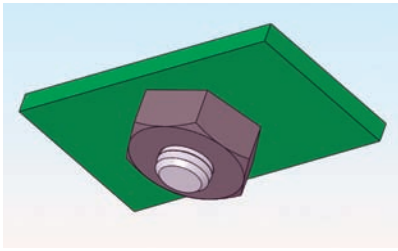

Color: Natural				
Standard Pack: 1000 per bag				
Part No.	"A"	"B"	Material	Thread
*HN#4-40-01	2.3	6.2	Nylon 6/6, RMS-01	#4-40
HN#6-32-01	2.8	7.7		#6-32
HN#8-32-01	3.2	8.6		#8-32
HN-M3-79	2.5	5.5	Polycarbonate, RMS-79	M3
HN-M4-01	3	6.9	Nylon 6/6, RMS-01	M4
HN-M4-79	3.3	8	Polycarbonate, RMS-79	M4
HN-M6-01	5.4	9.9	Nylon 6/6, RMS-01	M6

*Part does not carry the washer face

KNF
Kwik Nut Fastener

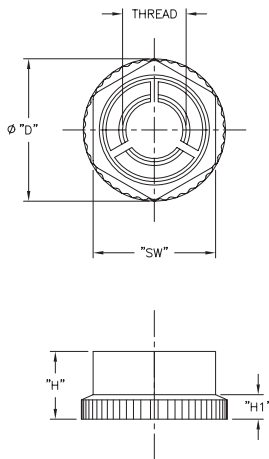
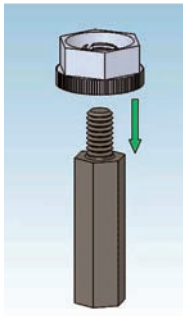

Material: Nylon 6/6, RMS-48 Color: Black					
Part No.	Standard Pack: 1000 per bag				
	Thread	"SW"	"D"	"H"	"H1"
KNF-30	M3	7	8.2	4	1.5
KNF-40	M4	8	9.4	4.7	1.5

Features

- To press fit over a threaded stud. To install, push down the length of the threaded fastener to desired location and lock with a 180° turn
- To unscrew, remove with a wrench

NNE
Nylon Nuts

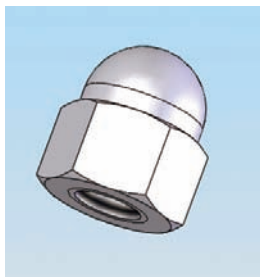

To DIN EN 34814, 1587

NNE-34814

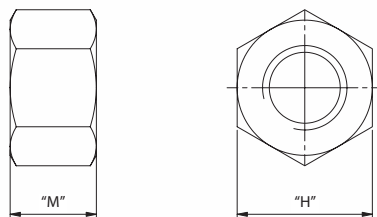

Material: UL94 HB Nylon 6/6, RMS-174 Color: Natural			
Standard Pack: 1000 per bag			
Part No.	Thread	"M"	"H"
NNE-34814-M2	M2	1.6	4
NNE-34814-M2.5	M2.5	2	5
NNE-34814-M3	M3	2.4	5.5
NNE-34814-M4	M4	3.2	7
NNE-34814-M5	M5	4.2	8
NNE-34814-M6	M6	5	10

Parts available by special order only.

NNE-1587

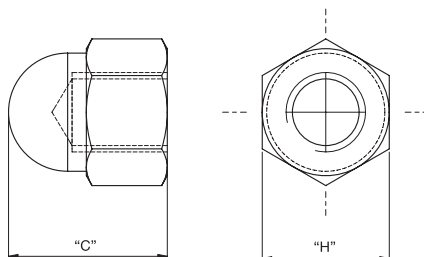

Material: UL94 HB Nylon 6/6, RMS-174 Color: Natural			
Standard Pack: 1000 per bag			
Part No.	Thread	"C"	"H"
NNE-1587-M3	M3	6	5.5
NNE-1587-M4	M4	8	7
NNE-1587-M5	M5	10	8
NNE-1587-M6	M6	12	10

Parts available by special order only.

CONVERSION CHARTS

inches		mm
1/64	0.015625	0.396875
1/32	0.03125	0.79375
3/64	0.046875	1.190625
1/16	0.0625	1.5875
5/64	0.078125	1.984375
3/32	0.09375	2.38125
7/64	0.109375	2.77812
1/8	0.125	3.175
9/64	0.140625	3.571875
5/32	0.15625	3.96875
11/64	0.171875	4.365625
3/16	0.1875	4.7625
13/64	0.203125	5.159375
7/32	0.21875	5.55625
15/64	0.234375	5.953125
1/4	0.25	6.35
17/64	0.265625	6.746875
9/32	0.281250	7.14375
19/64	0.296875	7.540625
5/16	0.312500	7.9375
21/64	0.328125	8.334375
11/32	0.34375	8.73125
23/64	0.359375	9.128125
3/8	0.375	9.525
25/64	0.390625	9.921875
13/32	0.40625	10.31875
27/64	0.421875	10.715625
7/16	0.4375	11.1125
29/64	0.453125	11.509375
15/32	0.46875	11.90625
31/64	0.484375	12.303125
1/2	0.5	12.7

inches		mm
33/64	0.515625	13.096875
17/32	0.53125	13.49375
35/64	0.546875	13.890625
9/16	0.5625	14.2875
37/64	0.578125	14.684375
19/32	0.59375	15.08125
39/64	0.609375	15.478125
5/8	0.625	15.875
41/64	0.640625	16.271875
21/32	0.65625	16.66875
43/64	0.671875	17.065625
11/16	0.6875	17.4625
45/64	0.703125	17.859375
23/32	0.71875	18.25625
47/64	0.734375	18.653125
3/4	0.75	19.05
49/64	0.765625	19.446875
25/32	0.78125	19.84375
51/64	0.796875	20.240625
13/16	0.8125	20.6375
53/64	0.828125	21.034375
27/32	0.84375	21.43125
55/64	0.859375	21.828125
7/8	0.875	22.225
57/64	0.890625	22.621875
29/32	0.90625	23.01875
59/64	0.921875	23.415625
15/16	0.9375	23.8125
61/64	0.953125	24.209375
31/32	0.96875	24.60625
63/64	0.984375	25.003125
1	1.00	25.4



in.	mm	in.	mm
0.001	0.0254	0.01	0.254
0.002	0.0508	0.02	0.508
0.003	0.0762	0.03	0.762
0.004	0.1016	0.04	1.016
0.005	0.1270	0.05	1.270
0.006	0.1524	0.06	1.524
0.007	0.1778	0.07	1.778
0.008	0.2032	0.08	2.032
0.009	0.2286	0.09	2.286

in.	mm
0.1	2.54
0.2	5.08
0.3	7.62
0.4	10.16
0.5	12.70
0.6	15.24
0.7	17.78
0.8	20.32
0.9	22.86

°C	°F	°C	°F	°C	°F	°C	°F	°C	°F	°C	°F
-50	-58	50	122	150	302	250	482	350	662	450	842
-45	-49	55	131	155	311	255	491	355	671	455	851
-40	-40	60	140	160	320	260	500	360	680	460	860
-35	-31	65	149	165	329	265	509	365	689	465	869
-30	-22	70	158	170	338	270	518	370	698	470	878
-25	-13	75	167	175	347	275	527	375	707	475	887
-20	-4	80	176	180	356	280	536	380	716	480	896
-15	5	85	185	185	365	285	545	3.85	725	485	905
-10	14	90	194	190	374	290	554	390	734	490	914
-5	23	95	203	195	383	295	563	395	743	495	923
0	32	100	212	200	392	300	572	400	752	500	932
5	41	105	221	205	401	305	581	405	761	505	941
10	50	110	230	210	410	310	590	410	770	510	950
15	59	115	239	215	419	315	599	415	779	515	959
20	68	120	248	220	428	320	608	420	788	520	968
25	77	125	257	225	437	325	617	425	797	525	977
30	86	130	266	230	446	330	626	430	806	530	986
35	95	135	275	235	455	335	635	435	815	535	995
40	104	140	284	240	464	340	644	440	824	540	1004
45	113	145	293	245	473	345	653	445	833	545	1013

Looking for pricing, stock, or lifecycle information?

Click below to explore more details on WIN SOURCE:

-  [View NSP-6-7-01 on WIN SOURCE](#)
-  [Essentra Components Information](#)

Optimize Your Supply Chain with WIN SOURCE Solutions

-  Global Sourcing Solution
-  Obsolete Management
-  Cost Control Management
-  Shortage Management
-  Alternative Solution
-  Excess Inventory Management