



## GENERAL DESCRIPTION

The SP2526A device is a dual +3.0V to +5.5V USB Supervisory Power Control Switch ideal for self-powered and bus-powered Universal Serial Bus (USB) applications.

Each switch has low on-resistance (110mΩ typical) and can supply 500mA minimum. The fault currents are limited to 1.0A typical and the flag output pin for each switch is available to indicate fault conditions to the USB controller. The thermal shutdown feature will prevent damage to the device when subjected to excessive current loads. The undervoltage lockout feature will ensure that the device will remain off unless there is a valid input voltage present.

The SP2526A is offered in a RoHS compliant "green"/halogen free 8-pin NSOIC package.

## APPLICATIONS

- Self Powered USB 2.0 and 3.0 Hubs
- USB Compliant V<sub>Bus</sub> Power Distribution
- Audio-Video Equipments
- Generic Power Switching

## FEATURES

- +3.0V to +5.5V Input Voltage Range
- Two Independent Power Switches
- Two Error Flag Outputs, Open Drain
- 2.6V Undervoltage Lockout
- 1.25A Short Circuit Current Limit
- 150mΩ Maximum On-Resistance
- 110μA On-State Supply Current
- 1μA Shutdown Current
- Output can be Forced Higher than Input (Off-State)
- Thermal Shutdown
- 1ms Soft Start Power Up, Fast Turn Off
- Active-high Version: SP2526A-1
- Active-low Version: SP2526A-2
- RoHS Compliant, Green/Halogen Free 8-Pin NSOIC Package

## TYPICAL APPLICATION DIAGRAM

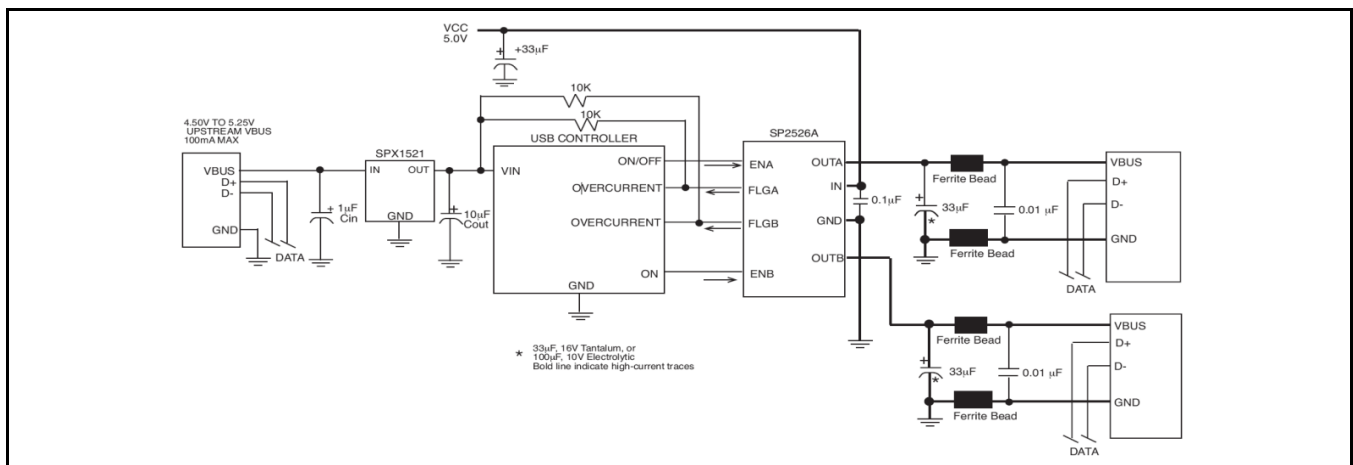

Fig. 1: SP2526A Application Diagram – Two Port Self Powered Hub

**ABSOLUTE MAXIMUM RATINGS**

These are stress ratings only and functional operation of the device at these ratings or any other above those indicated in the operation sections of the specifications below is not implied. Exposure to absolute maximum rating conditions for extended periods of time may affect reliability.

Supply Voltage  $V_{IN}$ ..... 7.0V  
 Fault Flag Voltage  $V_{FLG}$  ..... 7.0V  
 Fault Flag Current  $I_{FLG}$  .....50mA  
 Enable Input  $V_{EN}$ ..... -0.3V to 15V  
 Storage Temperature..... -65°C to 150°C  
 Soldering Temperature (10sec) ..... 260°C  
 Maximum Junction Temperature..... 125°C  
 Power Dissipation (NSOIC-8) .....  
 (derate 6.14mW/°C above 70°C)..... 500mW

**OPERATING RATINGS**

Ambient Temperature Range..... -40°C to 85°C

**ELECTRICAL SPECIFICATIONS**

Specifications with standard type are for an Operating Ambient Temperature of  $T_A = 25^\circ\text{C}$  only; limits applying over the full Operating Junction Temperature range are denoted by a "•". Minimum and Maximum limits are guaranteed through test, design, or statistical correlation. Typical values represent the most likely parametric norm at  $T_A = 25^\circ\text{C}$ , and are provided for reference purposes only. Unless otherwise indicated,  $V_{IN} = 5.0\text{V}$ ,  $T_A = 25^\circ\text{C}$ .

Parameter	Min.	Typ.	Max.	Units	Conditions
Supply Current		0.75	5.0	$\mu\text{A}$	$V_{EN} = \text{Logic "0"}$ OUT =open
		110	160		$V_{EN} = \text{Logic "1"}$ OUT =open
Enable Input Voltage	0.8	1.7		V	$V_{EN} = \text{Logic "0"}$
		2.0	2.4		$V_{EN} = \text{Logic "1"}$
Enable Input Current		0.01	1	$\mu\text{A}$	$V_{EN} = \text{Logic "0"}$
		0.01	1		$V_{EN} = \text{Logic "1"}$
Enable Input Capacitance		1		pF	
Output MOSFET Resistance		110	150	m $\Omega$	
Output turn-on delay		100		$\mu\text{s}$	$R_L = 10\Omega$ , each output
Output turn-on rise time		1000	4000	$\mu\text{s}$	$R_L = 10\Omega$ , each output
Output turn-off delay		0.8	20	$\mu\text{s}$	$R_L = 10\Omega$ , each output
Output turn-off fall time		0.7	20	$\mu\text{s}$	$R_L = 10\Omega$ , each output
Output Leakage Current			10	$\mu\text{A}$	
Current limit threshold	0.6	1.0	1.25	A	
Over temperature shutdown threshold		135		$^\circ\text{C}$	Temperature $T_J$ raising
		125			Temperature $T_J$ decreasing
Error Flag Output Resistance		10	25	$\Omega$	$V_{IN} = 5\text{V}$ , $I_L = 10\text{mA}$
		15	40		$V_{IN} = 3.3\text{V}$ , $I_L = 10\text{mA}$
Error Flag Current		0.01	1	$\mu\text{A}$	$V_{FLAG} = 5\text{V}$
UVLO threshold		2.6		V	$V_{IN}$ increasing
		2.4			$V_{IN}$ decreasing

**BLOCK DIAGRAM**

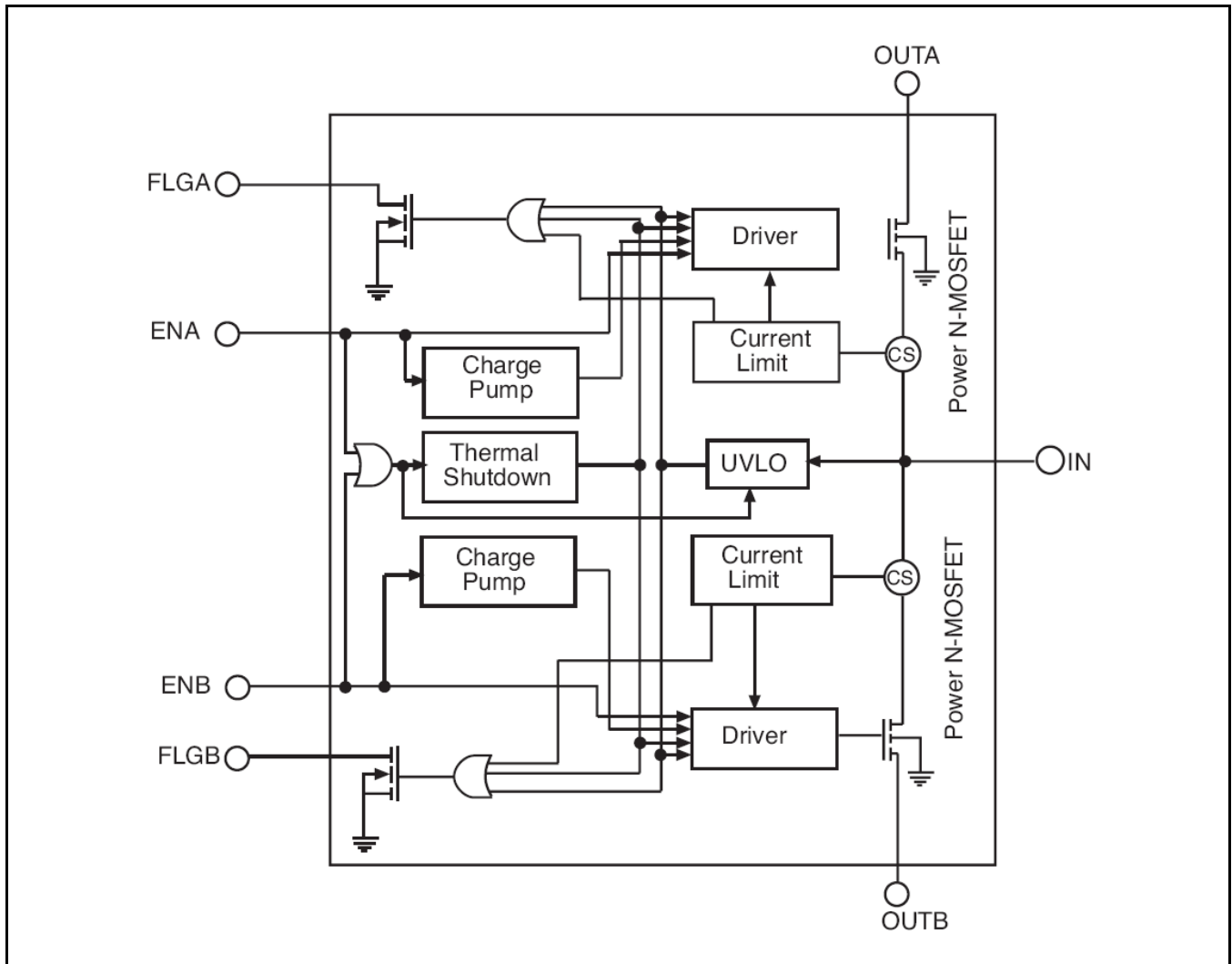

Fig. 2: SP2526A Block Diagram

**PIN ASSIGNMENT**

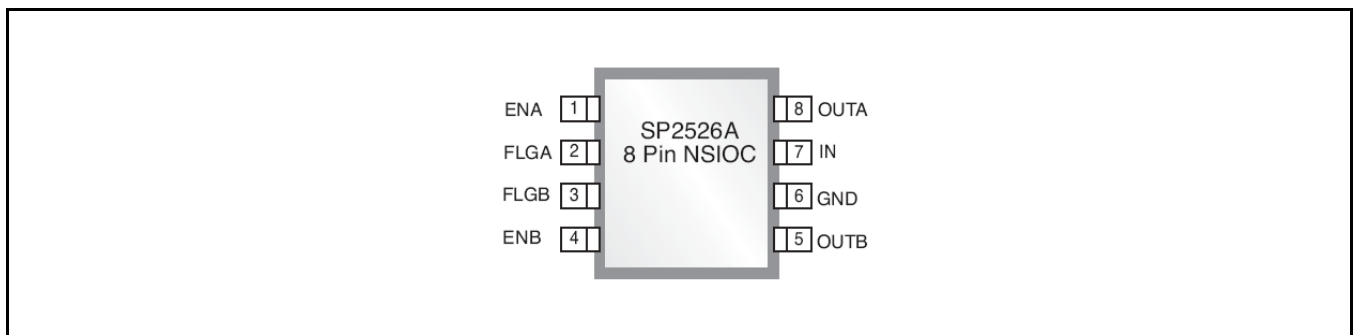

Fig. 3: SP2526A Pin Assignment

**PIN DESCRIPTION**

Name	Pin Number	Description
ENA	1	Enable Input for channel A. Active High for SP2526A-1 and Active Low for SP2526A-2
FLGA	2	An active-low and open-drained fault flag output for channel A. It can indicate current limit ENA is active. In normal mode operation (ENA and/or ENB is active), it also can indicate thermal shutdown or under voltage
FLGB	3	An active-low and open-drained fault flag output for channel B. It can indicate current limit ENA is active. In normal mode operation (ENA and/or ENB is active), it also can indicate thermal shutdown or under voltage
ENB	1	Enable Input for channel B. Active High for SP2526A-1 and Active Low for SP2526A-2
OUTB	5	Output for Channel B. This is the output pin of the MOSFET source of channel B, typically connected to the switched side of the load
GND	6	Ground
IN	7	Power Supply Input
OUTA	8	Output for Channel A. This is the output pin of the MOSFET source of channel A, typically connected to the switched side of the load

**ORDERING INFORMATION<sup>(1)</sup>**

Part Number	Temperature Range	Package	Packing Method	Lead Free <sup>(2)</sup>	Note 1
SP2526A-1EN-L/TR	-40°C ≤ T <sub>A</sub> ≤ +85°C	NSOIC8	Tape & Reel	Yes	Enable Active High
SP2526A-2EN-L/TR	-40°C ≤ T <sub>A</sub> ≤ +85°C	NSOIC8	Tape & Reel	Yes	Enable Active Low

**Notes:**

1. Refer to [www.maxlinear.com/SP2526A](http://www.maxlinear.com/SP2526A) for most up-to-date Ordering Information.
2. Visit [www.maxlinear.com](http://www.maxlinear.com) for additional information on Environmental Rating.

**TYPICAL PERFORMANCE CHARACTERISTICS**

All data taken at  $V_{IN} = 5.0V$ ,  $T_A = 25^{\circ}C$ , unless otherwise specified - Schematic and BOM from Application Information section of this datasheet.

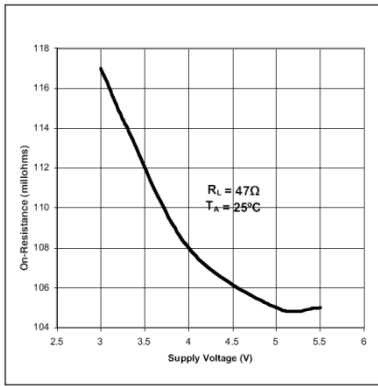

Fig. 4: Output On-Resistance vs Supply Voltage

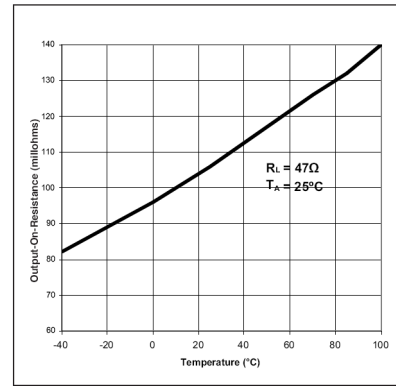

Fig. 5: Output On-Resistance vs Temperature

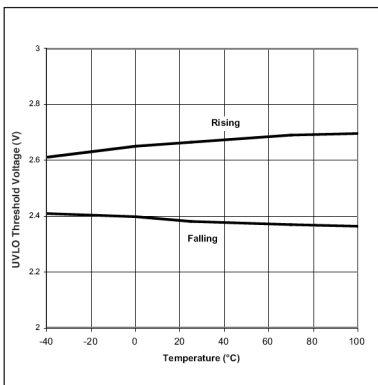

Fig. 6: UVLO Threshold vs Temperature

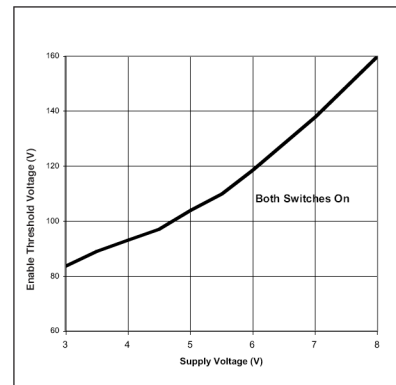

Fig. 7: On-state Supply Current vs Supply Voltage

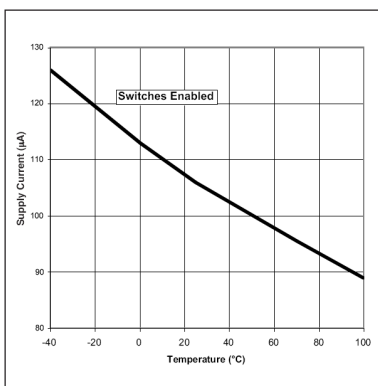

Fig. 8: On-state Supply Current vs Temperature

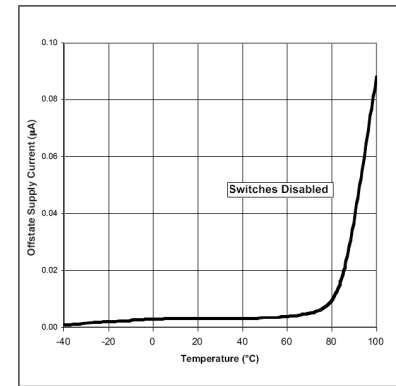

Fig. 9: Off-state Supply Current vs Temperature

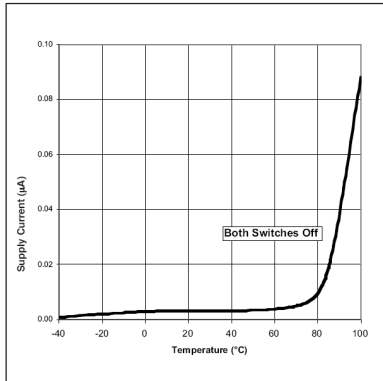

Fig. 10: Off-state Supply Current vs Supply Voltage

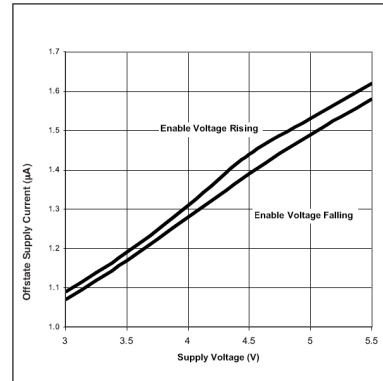

Fig. 11: Control Threshold vs Supply Voltage

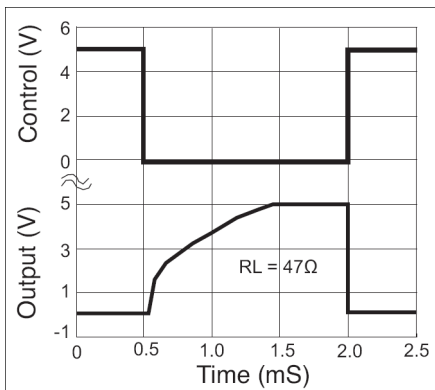

Fig. 12: Turn-on/Turn-off Characteristics

## APPLICATION INFORMATION

### ERROR FLAG

An open-drained output of an N-channel MOSFET, the FLG output is pulled low to signal the following fault conditions: input undervoltage, output current limit, and thermal shutdown.

### CURRENT LIMIT

The current limit threshold is preset internally. It protects the output MOSFET switches from damage resulting from undesirable short circuit conditions or excess inrush current, which is often encountered during hot plug-in. The low limit of the current limit threshold of the SP2526A allows a minimum current of 0.6A through the MOSFET switches. A current limit condition will signal the Error Flag.

### THERMAL SHUTDOWN

When the chip temperature exceeds 135°C for any reason other than overcurrent fault of either one of the two MOSFETs, the thermal shutdown function turns off both MOSFET switches and signals the error flag. A hysteresis of 10°C prevents the MOSFETs from turning back on until the chip temperature drops below 125°C. However, if thermal shutdown is triggered by chip temperature rise resulting from overcurrent fault condition of either one of the MOSFET switches, the thermal shutdown function will only turn off the switch that is in overcurrent condition and the other switch can still remain its normal operation. In other words, the thermal shutdown function of the two switches is independent of each other in the case of overcurrent fault.

### SUPPLY FILTERING

A 0.1µF to 1µF bypass capacitor from IN to GND, located near the device, is strongly recommended to control supply transients. Without a bypass capacitor, an output short may cause ringing on the input (from supply

lead inductance) which can damage internal control circuitry.

### TRANSIENT REQUIREMENTS

USB supports dynamic attachment (hot plugin) of peripherals. A current surge is caused by the input capacitance of a downstream device. Ferrite beads are recommended in series with all power and ground connector pins. Ferrite beads reduce EMI and limit the inrush current during hot-attachment by filtering high-frequency signals.

### SHORT CIRCUIT TRANSIENT

Bulk capacitance provides the short-term transient current needed during a hot-attachment event. A 33µF/16V tantalum or a 100µF/10V electrolytic capacitor mounted close to the downstream connector at each port should provide sufficient transient drop protection.

### PRINTED CIRCUIT LAYOUT

The Power circuitry of USB printed circuit boards requires a customized layout to maximize thermal dissipation and to minimize voltage drop and EMI.

### TEST CIRCUIT

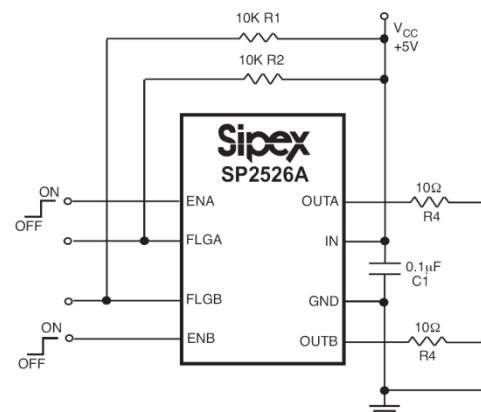

**PACKAGE SPECIFICATION**

**8-PIN NSOIC**

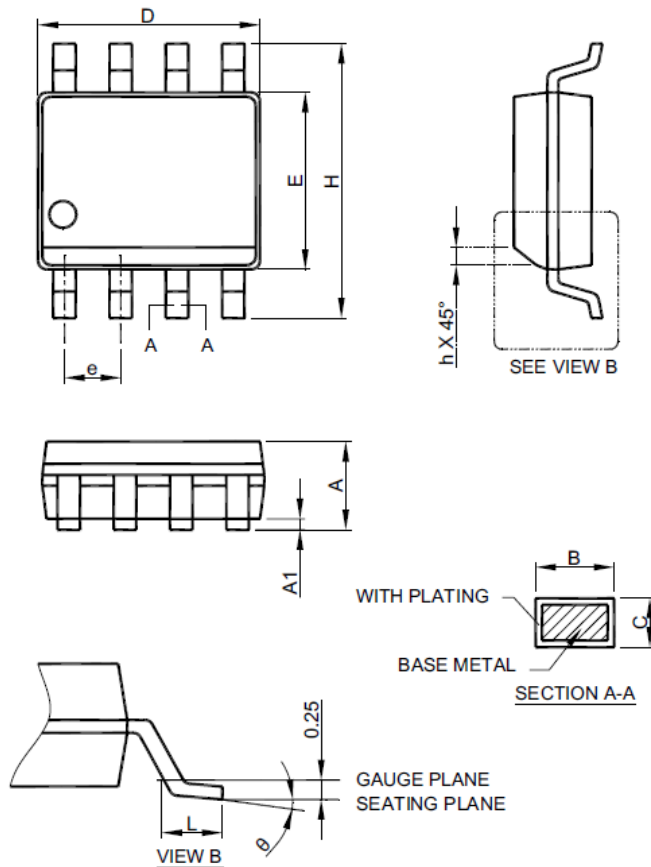

- Note: 1. Refer to JEDEC MS-012AA.  
 2. Dimension "D" does not include mold flash, protrusions or gate burrs. Mold flash, protrusion or gate burrs shall not exceed 6 mil per side.  
 3. Dimension "E" does not include inter-lead flash or protrusions.  
 4. Controlling dimension is millimeter, converted inch dimensions are not necessarily exact.

SYMBOL	8 PIN SOICN	
	MILLIMETERS	
	MIN.	MAX.
A	1.35	1.75
A1	0.10	0.25
B	0.33	0.51
C	0.19	0.25
D	4.80	5.00
E	3.80	4.00
e	1.27 BSC	
H	5.80	6.20
h	0.25	0.50
L	0.40	1.27
$\theta$	0°	8°



REVISION HISTORY

Revision	Date	Description
2.0.0	11/19/2010	Reformat of datasheet
2.1.0	11/04/2011	Updated package specification
2.1.1	01/22/2020	Updated to MaxLinear logo. Updated Ordering Information.



CORPORATE HEADQUARTERS:

5966 La Place Court  
Suite 100  
Carlsbad, CA 92008  
Tel.: +1 (760) 692-0711  
Fax: +1 (760) 444-8598  
[www.maxlinear.com](http://www.maxlinear.com)

The content of this document is furnished for informational use only, is subject to change without notice, and should not be construed as a commitment by Maxlinear, Inc. Maxlinear, Inc. Assumes no responsibility or liability for any errors or inaccuracies that may appear in the informational content contained in this guide. Complying with all applicable copyright laws is the responsibility of the user. Without limiting the rights under copyright, no part of this document may be reproduced into, stored in, or introduced into a retrieval system, or transmitted in any form or by any means (electronic, mechanical, photocopying, recording, or otherwise), or for any purpose, without the express written permission of Maxlinear, Inc.

Maxlinear, Inc. Does not recommend the use of any of its products in life support applications where the failure or malfunction of the product can reasonably be expected to cause failure of the life support system or to significantly affect its safety or effectiveness. Products are not authorized for use in such applications unless Maxlinear, Inc. Receives, in writing, assurances to its satisfaction that: (a) the risk of injury or damage has been minimized; (b) the user assumes all such risks; (c) potential liability of Maxlinear, Inc. Is adequately protected under the circumstances.

Maxlinear, Inc. May have patents, patent applications, trademarks, copyrights, or other intellectual property rights covering subject matter in this document. Except as expressly provided in any written license agreement from Maxlinear, Inc., the furnishing of this document does not give you any license to these patents, trademarks, copyrights, or other intellectual property.

Maxlinear, the Maxlinear logo, and any Maxlinear trademarks, MxL, Full-Spectrum Capture, FSC, G.now, AirPHY and the Maxlinear logo are all on the products sold, are all trademarks of Maxlinear, Inc. or one of Maxlinear's subsidiaries in the U.S.A. and other countries. All rights reserved. Other company trademarks and product names appearing herein are the property of their respective owners.

© 2011 - 2020 Maxlinear, Inc. All rights reserved.

## Looking for pricing, stock, or lifecycle information?

Click below to explore more details on WIN SOURCE:

 [View SP2526A-2EN-L on WIN SOURCE](#)

 [MaxLinear Inc Information](#)

## Optimize Your Supply Chain with WIN SOURCE Solutions

-  Global Sourcing Solution
-  Obsolete Management
-  Cost Control Management
-  Shortage Management
-  Alternative Solution
-  Excess Inventory Management