



**THE DATASHEET OF  
SN74ABT543ADW**



# SN54ABT543A, SN74ABT543A OCTAL REGISTERED TRANSCEIVERS WITH 3-STATE OUTPUTS

SCBS157F – JANUARY 1991 – REVISED MAY 1997

- State-of-the-Art *EPIC-II B*<sup>™</sup> BiCMOS Design Significantly Reduces Power Dissipation
- ESD Protection Exceeds 2000 V Per MIL-STD-883, Method 3015; Exceeds 200 V Using Machine Model (C = 200 pF, R = 0)
- Typical  $V_{OLP}$  (Output Ground Bounce) < 1 V at  $V_{CC} = 5$  V,  $T_A = 25^\circ\text{C}$
- High-Drive Outputs (–32-mA  $I_{OH}$ , 64-mA  $I_{OL}$ )
- Package Options Include Plastic Small-Outline (DW), Shrink Small-Outline (DB), and Thin Shrink Small-Outline (PW) Packages, Ceramic Chip Carriers (FK), Ceramic Flat (W) Package, and Plastic (NT) and Ceramic (JT) DIPs

## description

The 'ABT543A octal transceivers contain two sets of D-type latches for temporary storage of data flowing in either direction. Separate latch-enable ( $\overline{\text{LEAB}}$  or  $\overline{\text{LEBA}}$ ) and output-enable ( $\overline{\text{OEAB}}$  or  $\overline{\text{OEBA}}$ ) inputs are provided for each register to permit independent control in either direction of data flow.

The A-to-B enable ( $\overline{\text{CEAB}}$ ) input must be low to enter data from A or to output data from B. If  $\overline{\text{CEAB}}$  is low and  $\overline{\text{LEAB}}$  is low, the A-to-B latches are transparent; a subsequent low-to-high transition of  $\overline{\text{LEAB}}$  puts the A latches in the storage mode. With  $\overline{\text{CEAB}}$  and  $\overline{\text{OEAB}}$  both low, the 3-state B outputs are active and reflect the data present at the output of the A latches. Data flow from B to A is similar, but requires using the  $\overline{\text{CEBA}}$ ,  $\overline{\text{LEBA}}$ , and  $\overline{\text{OEBA}}$  inputs.

To ensure the high-impedance state during power up or power down,  $\overline{\text{OE}}$  should be tied to  $V_{CC}$  through a pullup resistor; the minimum value of the resistor is determined by the current-sinking capability of the driver.

The SN54ABT543A is characterized for operation over the full military temperature range of  $-55^\circ\text{C}$  to  $125^\circ\text{C}$ . The SN74ABT543A is characterized for operation from  $-40^\circ\text{C}$  to  $85^\circ\text{C}$ .

SN54ABT543A . . . JT OR W PACKAGE  
SN74ABT543A . . . DB, DW, NT, OR PW PACKAGE  
(TOP VIEW)

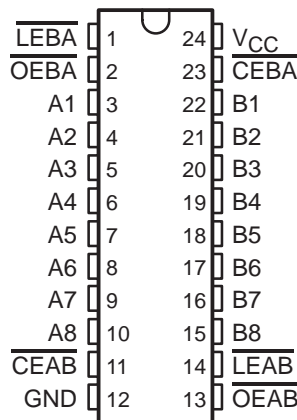

SN54ABT543A . . . FK PACKAGE  
(TOP VIEW)

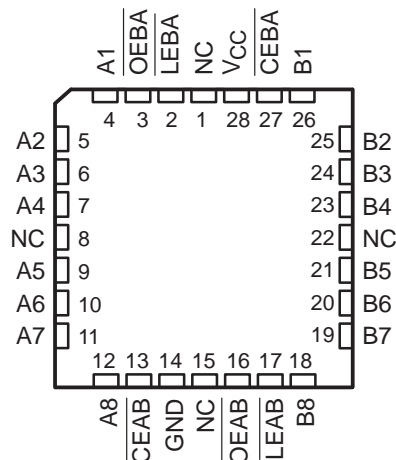

NC – No internal connection



Please be aware that an important notice concerning availability, standard warranty, and use in critical applications of Texas Instruments semiconductor products and disclaimers thereto appears at the end of this data sheet.

EPIC-II B is a trademark of Texas Instruments Incorporated.

PRODUCTION DATA information is current as of publication date. Products conform to specifications per the terms of Texas Instruments standard warranty. Production processing does not necessarily include testing of all parameters.



POST OFFICE BOX 655303 • DALLAS, TEXAS 75265

Copyright © 1997, Texas Instruments Incorporated

# SN54ABT543A, SN74ABT543A OCTAL REGISTERED TRANSCEIVERS WITH 3-STATE OUTPUTS

SCBS157F – JANUARY 1991 – REVISED MAY 1997

FUNCTION TABLE†

INPUTS				OUTPUT B
$\overline{CEAB}$	$\overline{LEAB}$	$\overline{OEAB}$	A	
H	X	X	X	Z
X	X	H	X	Z
L	H	L	X	$B_0^\ddagger$
L	L	L	L	L
L	L	L	H	H

† A-to-B data flow is shown; B-to-A flow control is the same except that it uses  $\overline{CEBA}$ ,  $\overline{LEBA}$ , and  $\overline{OEBA}$ .

‡ Output level before the indicated steady-state input conditions were established

## logic symbols§

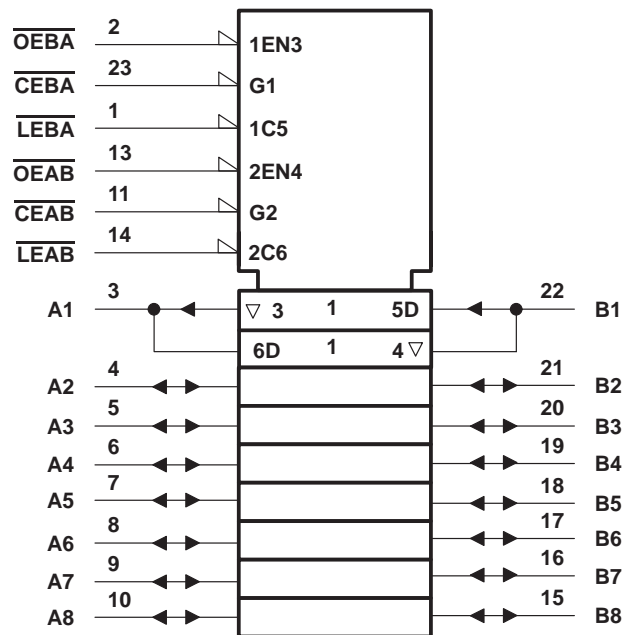

§ This symbol is in accordance with ANSI/IEEE Std 91-1984 and IEC Publication 617-12. Pin numbers shown are for the DB, DW, JT, NT, PW, and W packages.



# SN54ABT543A, SN74ABT543A OCTAL REGISTERED TRANSCIEVERS WITH 3-STATE OUTPUTS

SCBS157F – JANUARY 1991 – REVISED MAY 1997

## recommended operating conditions (see Note 3)

		SN54ABT543A		SN74ABT543A		UNIT
		MIN	MAX	MIN	MAX	
V <sub>CC</sub>	Supply voltage	4.5	5.5	4.5	5.5	V
V <sub>IH</sub>	High-level input voltage	2		2		V
V <sub>IL</sub>	Low-level input voltage		0.8		0.8	V
V <sub>I</sub>	Input voltage	0	V <sub>CC</sub>	0	V <sub>CC</sub>	V
I <sub>OH</sub>	High-level output current		-24		-32	mA
I <sub>OL</sub>	Low-level output current		48		64	mA
Δt/Δv	Input transition rise or fall rate	Outputs enabled		5	5	ns/V
T <sub>A</sub>	Operating free-air temperature	-55	125	-40	85	°C

NOTE 3: Unused pins (input or I/O) must be held high or low to prevent them from floating.

## electrical characteristics over recommended operating free-air temperature range (unless otherwise noted)

PARAMETER	TEST CONDITIONS	T <sub>A</sub> = 25°C			SN54ABT543A		SN74ABT543A		UNIT	
		MIN	TYP†	MAX	MIN	MAX	MIN	MAX		
V <sub>IK</sub>	V <sub>CC</sub> = 4.5 V, I <sub>I</sub> = -18 mA			-1.2		-1.2		-1.2	V	
V <sub>OH</sub>	V <sub>CC</sub> = 4.5 V, I <sub>OH</sub> = -3 mA		2.5		2.5		2.5		V	
	V <sub>CC</sub> = 5 V, I <sub>OH</sub> = -3 mA		3		3		3			
	V <sub>CC</sub> = 4.5 V, I <sub>OH</sub> = -24 mA		2		2					
V <sub>OL</sub>	V <sub>CC</sub> = 4.5 V, I <sub>OL</sub> = 48 mA			0.55		0.55			V	
				0.55*			0.55			
V <sub>hys</sub>			100						mV	
I <sub>I</sub>	Control inputs	V <sub>CC</sub> = 5.5 V, V <sub>I</sub> = V <sub>CC</sub> or GND		±1		±1		±1	μA	
	A or B ports			±100		±100		±100		
I <sub>OZH</sub> ‡	V <sub>CC</sub> = 5.5 V, V <sub>O</sub> = 2.7 V			10§		10§		10§	μA	
I <sub>OZL</sub> ‡	V <sub>CC</sub> = 5.5 V, V <sub>O</sub> = 0.5 V			-10§		-10§		-10§	μA	
I <sub>off</sub>	V <sub>CC</sub> = 0, V <sub>I</sub> or V <sub>O</sub> ≤ 4.5 V			±100				±100	μA	
I <sub>CEX</sub>	V <sub>CC</sub> = 5.5 V, V <sub>O</sub> = 5.5 V	Outputs high		50		50		50	μA	
I <sub>O</sub> ¶	V <sub>CC</sub> = 5.5 V, V <sub>O</sub> = 2.5 V		-50*	-100	-180*	-50	-200	-50	-180	mA
I <sub>CC</sub>	V <sub>CC</sub> = 5.5 V, I <sub>O</sub> = 0, V <sub>I</sub> = V <sub>CC</sub> or GND	Outputs high		1	250*		350		250	μA
		Outputs low		24	30*		34		30	mA
		Outputs disabled		0.5	250*		350		250	μA
ΔI <sub>CC</sub> #	V <sub>CC</sub> = 5.5 V, One input at 3.4 V, Other inputs at V <sub>CC</sub> or GND			1.5		1.5		1.5	mA	
C <sub>i</sub>	Control inputs	V <sub>I</sub> = 2.5 V or 0.5 V		4					pF	
C <sub>io</sub>	A or B ports	V <sub>O</sub> = 2.5 V or 0.5 V		7					pF	

\* On products compliant to MIL-PRF-38535, this parameter does not apply.

† All typical values are at V<sub>CC</sub> = 5 V.

‡ The parameters I<sub>OZH</sub> and I<sub>OZL</sub> include the input leakage current.

§ This data sheet limit may vary among suppliers.

¶ Not more than one output should be tested at a time, and the duration of the test should not exceed one second.

# This is the increase in supply current for each input that is at the specified TTL voltage level rather than V<sub>CC</sub> or GND.



**SN54ABT543A, SN74ABT543A**  
**OCTAL REGISTERED TRANSCEIVERS**  
**WITH 3-STATE OUTPUTS**

SCBS157F – JANUARY 1991 – REVISED MAY 1997

timing requirements over recommended ranges of supply voltage and operating free-air temperature (unless otherwise noted) (see Figure 1)

			SN54ABT543A		UNIT		
			V <sub>CC</sub> = 5 V, T <sub>A</sub> = 25°C			MIN	MAX
			MIN	MAX			
t <sub>w</sub>	Pulse duration, $\overline{\text{LEAB}}$ or $\overline{\text{LEBA}}$ low		3.5	3.5	ns		
t <sub>su</sub>	Setup time	Data before $\overline{\text{LEAB}}$ or $\overline{\text{LEBA}}\uparrow$	High	2.5	2.5	ns	
			Low	3	3		
		Data before $\overline{\text{CEAB}}$ or $\overline{\text{CEBA}}\uparrow$	High	2.5	2.5		
			Low	3	3		
t <sub>h</sub>	Hold time	Data after $\overline{\text{LEAB}}$ or $\overline{\text{LEBA}}\uparrow$	1	1	ns		
		Data after $\overline{\text{CEAB}}$ or $\overline{\text{CEBA}}\uparrow$	1	1			

timing requirements over recommended ranges of supply voltage and operating free-air temperature (unless otherwise noted) (see Figure 1)

			SN74ABT543A		UNIT		
			V <sub>CC</sub> = 5 V, T <sub>A</sub> = 25°C			MIN	MAX
			MIN	MAX			
t <sub>w</sub>	Pulse duration, $\overline{\text{LEAB}}$ or $\overline{\text{LEBA}}$ low		3.5	3.5	ns		
t <sub>su</sub>	Setup time	Data before $\overline{\text{LEAB}}$ or $\overline{\text{LEBA}}\uparrow$	High	3.5	3.5	ns	
			Low	3	3		
		Data before $\overline{\text{CEAB}}$ or $\overline{\text{CEBA}}\uparrow$	High	3.5	3.5		
			Low	3	3		
t <sub>h</sub>	Hold time	Data after $\overline{\text{LEAB}}$ or $\overline{\text{LEBA}}\uparrow$	0.5	0.5	ns		
		Data after $\overline{\text{CEAB}}$ or $\overline{\text{CEBA}}\uparrow$	0.5	0.5			



**SN54ABT543A, SN74ABT543A**  
**OCTAL REGISTERED TRANSCEIVERS**  
**WITH 3-STATE OUTPUTS**

SCBS157F – JANUARY 1991 – REVISED MAY 1997

switching characteristics over recommended ranges of supply voltage and operating free-air temperature,  $C_L = 50$  pF (unless otherwise noted) (see Figure 1)

PARAMETER	FROM (INPUT)	TO (OUTPUT)	SN54ABT543A				UNIT	
			$V_{CC} = 5$ V, $T_A = 25^\circ$ C			MIN		MAX
			MIN	TYP	MAX			
$t_{PLH}$	A or B	B or A	1.6†	4.4	4.4	1.6†	5.5	ns
$t_{PHL}$			1.6	4.4	5.1	1.6	6.2	
$t_{PLH}$	$\overline{LEBA}$ or $\overline{LEAB}$	A or B	1.6†	4.1	5.1	1.6†	6.6	ns
$t_{PHL}$			1.6	4.6	5.4	1.6	6.4	
$t_{PZH}$	$\overline{OEBA}$ or $\overline{OEAB}$	A or B	1.4	3.9	4.1	1.4	5.1	ns
$t_{PZL}$			2	5	4.9	2	5.8	
$t_{PHZ}$	$\overline{OEBA}$ or $\overline{OEAB}$	A or B	2.5†	5.9	5.8	2.5†	6.9	ns
$t_{PLZ}$			2.5†	5.5	6.1	2.5†	7.6	
$t_{PZH}$	$\overline{CEBA}$ or $\overline{CEAB}$	A or B	1.4	3.9	4.7	1.4	5.6	ns
$t_{PZL}$			2	5	5.7	2	6.2	
$t_{PHZ}$	CEBA or CEAB	A or B	3.2†	5.9	6.5	3.2†	7.3	ns
$t_{PLZ}$			2.5†	5.5	6.7	2.5†	7.8	

† This data sheet limit may vary among suppliers.

switching characteristics over recommended ranges of supply voltage and operating free-air temperature,  $C_L = 50$  pF (unless otherwise noted) (see Figure 1)

PARAMETER	FROM (INPUT)	TO (OUTPUT)	SN74ABT543A				UNIT	
			$V_{CC} = 5$ V, $T_A = 25^\circ$ C			MIN		MAX
			MIN	TYP	MAX			
$t_{PLH}$	A or B	B or A	1.8†	4.4	5.9	1.8†	6.9	ns
$t_{PHL}$			1.9	4.4	5.9	1.9	6.9	
$t_{PLH}$	$\overline{LEBA}$ or $\overline{LEAB}$	A or B	1.5†	4.1	5.6	1.5†	6.6	ns
$t_{PHL}$			2.1	4.6	6.1	2.1	7.1	
$t_{PZH}$	$\overline{OEBA}$ or $\overline{OEAB}$	A or B	1.4	3.9	5.4	1.4	6.4	ns
$t_{PZL}$			2.5	5	6.5	2.5	7.5	
$t_{PHZ}$	$\overline{OEBA}$ or $\overline{OEAB}$	A or B	2.5†	5.9	7.4	2.5†	8.4	ns
$t_{PLZ}$			2.5†	5.5	7	2.5†	8	
$t_{PZH}$	$\overline{CEBA}$ or $\overline{CEAB}$	A or B	1.4	3.9	5.4	1.4	6.4	ns
$t_{PZL}$			2.5	5	6.5	2.5	7.5	
$t_{PHZ}$	$\overline{CEBA}$ or $\overline{CEAB}$	A or B	2.9†	5.9	7.4	2.9†	8.4	ns
$t_{PLZ}$			2.4†	5.5	7	2.4†	8	

† This data sheet limit may vary among suppliers.



PARAMETER MEASUREMENT INFORMATION

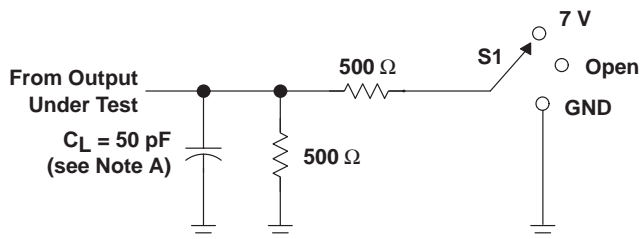

TEST	S1
$t_{PLH}/t_{PHL}$	Open
$t_{PLZ}/t_{PZL}$	7 V
$t_{PHZ}/t_{PZH}$	Open

LOAD CIRCUIT

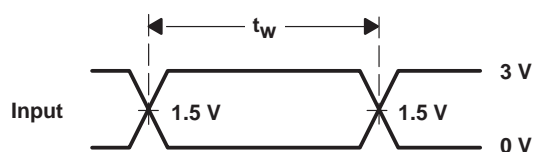

VOLTAGE WAVEFORMS  
 PULSE DURATION

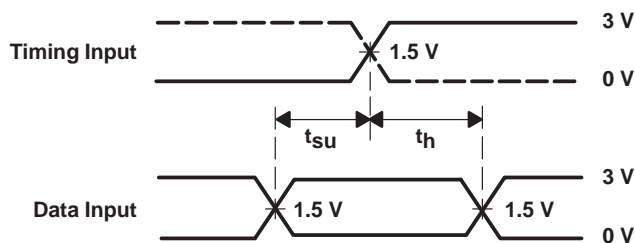

VOLTAGE WAVEFORMS  
 SETUP AND HOLD TIMES

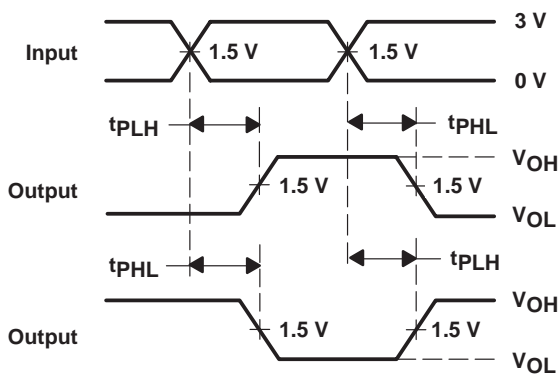

VOLTAGE WAVEFORMS  
 PROPAGATION DELAY TIMES  
 INVERTING AND NONINVERTING OUTPUTS

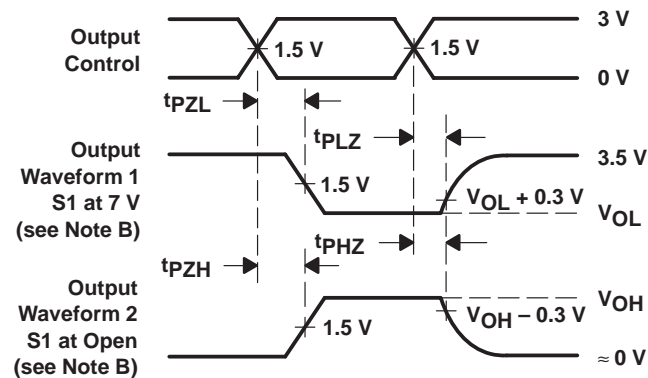

VOLTAGE WAVEFORMS  
 ENABLE AND DISABLE TIMES  
 LOW- AND HIGH-LEVEL ENABLING

- NOTES: A.  $C_L$  includes probe and jig capacitance.  
 B. Waveform 1 is for an output with internal conditions such that the output is low except when disabled by the output control. Waveform 2 is for an output with internal conditions such that the output is high except when disabled by the output control.  
 C. All input pulses are supplied by generators having the following characteristics:  $PRR \leq 10 \text{ MHz}$ ,  $Z_O = 50 \Omega$ ,  $t_r \leq 2.5 \text{ ns}$ ,  $t_f \leq 2.5 \text{ ns}$ .  
 D. The outputs are measured one at a time with one transition per measurement.

Figure 1. Load Circuit and Voltage Waveforms

**PACKAGING INFORMATION**

Orderable Device	Status (1)	Package Type	Package Drawing	Pins	Package Qty	Eco Plan (2)	Lead finish/ Ball material (6)	MSL Peak Temp (3)	Op Temp (°C)	Device Marking (4/5)	Samples
5962-9231402Q3A	ACTIVE	LCCC	FK	28	42	Non-RoHS & Green	SNPB	N / A for Pkg Type	-55 to 125	5962-9231402Q3A SNJ54 ABT543AFK	<a href="#">Samples</a>
SN74ABT543ADBR	ACTIVE	SSOP	DB	24	2000	RoHS & Green	NIPDAU	Level-1-260C-UNLIM	-40 to 85	AB543A	<a href="#">Samples</a>
SN74ABT543ADBRG4	ACTIVE	SSOP	DB	24	2000	RoHS & Green	NIPDAU	Level-1-260C-UNLIM	-40 to 85	AB543A	<a href="#">Samples</a>
SN74ABT543ADW	ACTIVE	SOIC	DW	24	25	RoHS & Green	NIPDAU	Level-1-260C-UNLIM	-40 to 85	ABT543A	<a href="#">Samples</a>
SN74ABT543ADWR	ACTIVE	SOIC	DW	24	2000	RoHS & Green	NIPDAU	Level-1-260C-UNLIM	-40 to 85	ABT543A	<a href="#">Samples</a>
SN74ABT543APW	ACTIVE	TSSOP	PW	24	60	RoHS & Green	NIPDAU	Level-1-260C-UNLIM	-40 to 85	AB543A	<a href="#">Samples</a>
SN74ABT543APWR	ACTIVE	TSSOP	PW	24	2000	RoHS & Green	NIPDAU	Level-1-260C-UNLIM	-40 to 85	AB543A	<a href="#">Samples</a>
SNJ54ABT543AFK	ACTIVE	LCCC	FK	28	42	Non-RoHS & Green	SNPB	N / A for Pkg Type	-55 to 125	5962-9231402Q3A SNJ54 ABT543AFK	<a href="#">Samples</a>

(1) The marketing status values are defined as follows:

**ACTIVE:** Product device recommended for new designs.

**LIFEBUY:** TI has announced that the device will be discontinued, and a lifetime-buy period is in effect.

**NRND:** Not recommended for new designs. Device is in production to support existing customers, but TI does not recommend using this part in a new design.

**PREVIEW:** Device has been announced but is not in production. Samples may or may not be available.

**OBSELETE:** TI has discontinued the production of the device.

(2) **RoHS:** TI defines "RoHS" to mean semiconductor products that are compliant with the current EU RoHS requirements for all 10 RoHS substances, including the requirement that RoHS substance do not exceed 0.1% by weight in homogeneous materials. Where designed to be soldered at high temperatures, "RoHS" products are suitable for use in specified lead-free processes. TI may reference these types of products as "Pb-Free".

**RoHS Exempt:** TI defines "RoHS Exempt" to mean products that contain lead but are compliant with EU RoHS pursuant to a specific EU RoHS exemption.

**Green:** TI defines "Green" to mean the content of Chlorine (Cl) and Bromine (Br) based flame retardants meet JS709B low halogen requirements of <=1000ppm threshold. Antimony trioxide based flame retardants must also meet the <=1000ppm threshold requirement.

(3) MSL, Peak Temp. - The Moisture Sensitivity Level rating according to the JEDEC industry standard classifications, and peak solder temperature.

- (4) There may be additional marking, which relates to the logo, the lot trace code information, or the environmental category on the device.
- (5) Multiple Device Markings will be inside parentheses. Only one Device Marking contained in parentheses and separated by a "~" will appear on a device. If a line is indented then it is a continuation of the previous line and the two combined represent the entire Device Marking for that device.
- (6) Lead finish/Ball material - Orderable Devices may have multiple material finish options. Finish options are separated by a vertical ruled line. Lead finish/Ball material values may wrap to two lines if the finish value exceeds the maximum column width.

**Important Information and Disclaimer:**The information provided on this page represents TI's knowledge and belief as of the date that it is provided. TI bases its knowledge and belief on information provided by third parties, and makes no representation or warranty as to the accuracy of such information. Efforts are underway to better integrate information from third parties. TI has taken and continues to take reasonable steps to provide representative and accurate information but may not have conducted destructive testing or chemical analysis on incoming materials and chemicals. TI and TI suppliers consider certain information to be proprietary, and thus CAS numbers and other limited information may not be available for release.

In no event shall TI's liability arising out of such information exceed the total purchase price of the TI part(s) at issue in this document sold by TI to Customer on an annual basis.

**OTHER QUALIFIED VERSIONS OF SN54ABT543A, SN74ABT543A :**

- Catalog : [SN74ABT543A](#)
- Military : [SN54ABT543A](#)

NOTE: Qualified Version Definitions:

- Catalog - TI's standard catalog product
- Military - QML certified for Military and Defense Applications

**TAPE AND REEL INFORMATION**

**QUADRANT ASSIGNMENTS FOR PIN 1 ORIENTATION IN TAPE**

\*All dimensions are nominal

Device	Package Type	Package Drawing	Pins	SPQ	Reel Diameter (mm)	Reel Width W1 (mm)	A0 (mm)	B0 (mm)	K0 (mm)	P1 (mm)	W (mm)	Pin1 Quadrant
SN74ABT543ADBR	SSOP	DB	24	2000	330.0	16.4	8.2	8.8	2.5	12.0	16.0	Q1
SN74ABT543ADWR	SOIC	DW	24	2000	330.0	24.4	10.75	15.7	2.7	12.0	24.0	Q1
SN74ABT543APWR	TSSOP	PW	24	2000	330.0	16.4	6.95	8.3	1.6	8.0	16.0	Q1

**TAPE AND REEL BOX DIMENSIONS**

\*All dimensions are nominal

Device	Package Type	Package Drawing	Pins	SPQ	Length (mm)	Width (mm)	Height (mm)
SN74ABT543ADBR	SSOP	DB	24	2000	356.0	356.0	35.0
SN74ABT543ADWR	SOIC	DW	24	2000	350.0	350.0	43.0
SN74ABT543APWR	TSSOP	PW	24	2000	356.0	356.0	35.0

**TUBE**

\*All dimensions are nominal

Device	Package Name	Package Type	Pins	SPQ	L (mm)	W (mm)	T (μm)	B (mm)
SN74ABT543ADW	DW	SOIC	24	25	506.98	12.7	4826	6.6
SN74ABT543APW	PW	TSSOP	24	60	530	10.2	3600	3.5

FK (S-CQCC-N\*\*)

LEADLESS CERAMIC CHIP CARRIER

28 TERMINAL SHOWN



NO. OF TERMINALS **	A		B	
	MIN	MAX	MIN	MAX
20	0.342 (8,69)	0.358 (9,09)	0.307 (7,80)	0.358 (9,09)
28	0.442 (11,23)	0.458 (11,63)	0.406 (10,31)	0.458 (11,63)
44	0.640 (16,26)	0.660 (16,76)	0.495 (12,58)	0.560 (14,22)
52	0.740 (18,78)	0.761 (19,32)	0.495 (12,58)	0.560 (14,22)
68	0.938 (23,83)	0.962 (24,43)	0.850 (21,6)	0.858 (21,8)
84	1.141 (28,99)	1.165 (29,59)	1.047 (26,6)	1.063 (27,0)



4040140/D 01/11

- NOTES:
- All linear dimensions are in inches (millimeters).
  - This drawing is subject to change without notice.
  - This package can be hermetically sealed with a metal lid.
  - Falls within JEDEC MS-004

# PW0024A



# PACKAGE OUTLINE

## TSSOP - 1.2 mm max height

SMALL OUTLINE PACKAGE

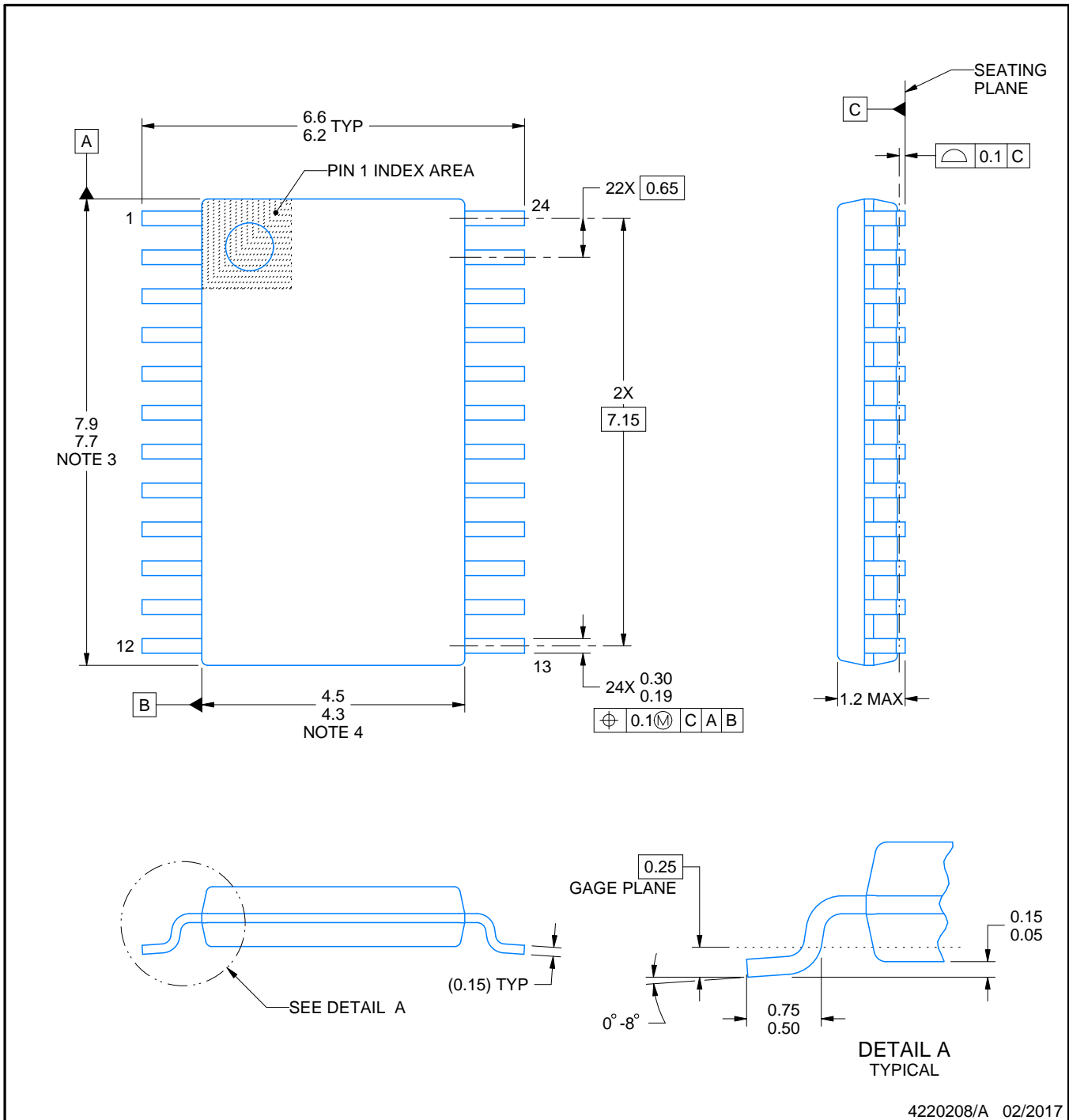

4220208/A 02/2017

### NOTES:

1. All linear dimensions are in millimeters. Any dimensions in parenthesis are for reference only. Dimensioning and tolerancing per ASME Y14.5M.
2. This drawing is subject to change without notice.
3. This dimension does not include mold flash, protrusions, or gate burrs. Mold flash, protrusions, or gate burrs shall not exceed 0.15 mm per side.
4. This dimension does not include interlead flash. Interlead flash shall not exceed 0.25 mm per side.
5. Reference JEDEC registration MO-153.

# EXAMPLE BOARD LAYOUT

PW0024A

TSSOP - 1.2 mm max height

SMALL OUTLINE PACKAGE



LAND PATTERN EXAMPLE  
EXPOSED METAL SHOWN  
SCALE: 10X



SOLDER MASK DETAILS

4220208/A 02/2017

NOTES: (continued)

- 6. Publication IPC-7351 may have alternate designs.
- 7. Solder mask tolerances between and around signal pads can vary based on board fabrication site.

# EXAMPLE STENCIL DESIGN

PW0024A

TSSOP - 1.2 mm max height

SMALL OUTLINE PACKAGE



NOTES: (continued)

8. Laser cutting apertures with trapezoidal walls and rounded corners may offer better paste release. IPC-7525 may have alternate design recommendations.
9. Board assembly site may have different recommendations for stencil design.



DW (R-PDSO-G24)

PLASTIC SMALL OUTLINE



4209202-5/F 08/13

- NOTES:
- A. All linear dimensions are in millimeters.
  - B. This drawing is subject to change without notice.
  - C. Refer to IPC7351 for alternate board design.
  - D. Laser cutting apertures with trapezoidal walls and also rounding corners will offer better paste release. Customers should contact their board assembly site for stencil design recommendations. Refer to IPC-7525
  - E. Customers should contact their board fabrication site for solder mask tolerances between and around signal pads.

DB (R-PDSO-G\*\*)

PLASTIC SMALL-OUTLINE

28 PINS SHOWN



- NOTES: A. All linear dimensions are in millimeters.  
 B. This drawing is subject to change without notice.  
 C. Body dimensions do not include mold flash or protrusion not to exceed 0,15.  
 D. Falls within JEDEC MO-150

## IMPORTANT NOTICE AND DISCLAIMER

TI PROVIDES TECHNICAL AND RELIABILITY DATA (INCLUDING DATA SHEETS), DESIGN RESOURCES (INCLUDING REFERENCE DESIGNS), APPLICATION OR OTHER DESIGN ADVICE, WEB TOOLS, SAFETY INFORMATION, AND OTHER RESOURCES "AS IS" AND WITH ALL FAULTS, AND DISCLAIMS ALL WARRANTIES, EXPRESS AND IMPLIED, INCLUDING WITHOUT LIMITATION ANY IMPLIED WARRANTIES OF MERCHANTABILITY, FITNESS FOR A PARTICULAR PURPOSE OR NON-INFRINGEMENT OF THIRD PARTY INTELLECTUAL PROPERTY RIGHTS.

These resources are intended for skilled developers designing with TI products. You are solely responsible for (1) selecting the appropriate TI products for your application, (2) designing, validating and testing your application, and (3) ensuring your application meets applicable standards, and any other safety, security, regulatory or other requirements.

These resources are subject to change without notice. TI grants you permission to use these resources only for development of an application that uses the TI products described in the resource. Other reproduction and display of these resources is prohibited. No license is granted to any other TI intellectual property right or to any third party intellectual property right. TI disclaims responsibility for, and you will fully indemnify TI and its representatives against, any claims, damages, costs, losses, and liabilities arising out of your use of these resources.

TI's products are provided subject to [TI's Terms of Sale](#) or other applicable terms available either on [ti.com](https://www.ti.com) or provided in conjunction with such TI products. TI's provision of these resources does not expand or otherwise alter TI's applicable warranties or warranty disclaimers for TI products.

TI objects to and rejects any additional or different terms you may have proposed.

Mailing Address: Texas Instruments, Post Office Box 655303, Dallas, Texas 75265  
Copyright © 2023, Texas Instruments Incorporated

## Looking for pricing, stock, or lifecycle information?

Click below to explore more details on WIN SOURCE:

 [View SN74ABT543ADW on WIN SOURCE](#)

 [Texas Instruments](#) Information

## Optimize Your Supply Chain with WIN SOURCE Solutions

-  Global Sourcing Solution
-  Obsolete Management
-  Cost Control Management
-  Shortage Management
-  Alternative Solution
-  Excess Inventory Management