



**THE DATASHEET OF
SMCJ28CAQ-13-F**



Product Summary (@T_A = +25°C)

| P _{PK} | I _{FSM} | V _{RWM} | PM _(AV) |
|-----------------|------------------|------------------|--------------------|
| 1500W | 200A | 5V to 110V | 5W |

Description and Applications

Suitable to protect sensitive automotive circuits against surges defined in ISO7637-2 and against electrostatic discharges according to ISO10605.

Compliance with following standards:

- ISO10605, C = 150pF, R = 330Ω:
30kV (Air Discharge)
30kV (Contact Discharge)
- ISO7637-2
Pulse 1: V_S = -100V
Pulse 2a: V_S = +50V
Pulse 3a: V_S = -150V
Pulse 3b: V_S = +100V

Features and Benefits

- 1,500W Peak Pulse Power Dissipation
- 5V to 110V Standoff Voltages
- Glass Passivated Die Construction
- Unidirectional and Bidirectional Versions Available
- Excellent Clamping Capability
- Fast Response Time
- Lead-Free Finish; RoHS Compliant (Notes 1 & 2)**
- Halogen and Antimony Free. "Green" Device (Note 3)**
- The DIODES™ SMCJ5.0(C)AQ – SMCJ110(C)AQ are suitable for automotive applications requiring specific change control; these parts are AEC-Q101 qualified, PPAP capable, and manufactured in IATF 16949 certified facilities.**
<https://www.diodes.com/quality/product-definitions/>

Mechanical Data

- Package: SMC
- Package Material: Molded Plastic. UL Flammability Classification Rating 94V-0
- Moisture Sensitivity: Level 1 per J-STD-020
- Terminals: Lead-Free Plating (Matte Tin Finish). Solderable per MIL-STD-202, Method 208 [Ⓔ]
- Polarity Indicator: Cathode Band (Note: Bidirectional devices have no polarity indicator.)
- Weight: 0.21 grams (Approximate)

SMC

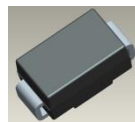

Top View

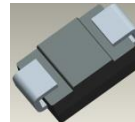

Bottom View

Ordering Information (Note 4)

| Part Number | Package | Packing | |
|--------------------|---------|---------|-------------|
| | | Qty. | Carrier |
| SMCJX.X(C)AQ-13-F* | SMC | 3000 | Tape & Reel |
| SMCJXX(C)AQ-13-F* | SMC | 3000 | Tape & Reel |
| SMCJXXX(C)AQ-13-F* | SMC | 3000 | Tape & Reel |

*X = Device Voltage, e.g., SMCJ14AQ-13-F.

- Notes:
- EU Directive 2002/95/EC (RoHS), 2011/65/EU (RoHS 2) & 2015/863/EU (RoHS 3) compliant. All applicable RoHS exemptions applied.
 - See <https://www.diodes.com/quality/lead-free/> for more information about Diodes Incorporated's definitions of Halogen- and Antimony-free, "Green" and Lead-free.
 - Halogen- and Antimony-free "Green" products are defined as those which contain <900ppm bromine, <900ppm chlorine (<1500ppm total Br + Cl) and <1000ppm antimony compounds.
 - For packaging details, go to our website at <https://www.diodes.com/design/support/packaging/diodes-packaging/>.

Marking Information

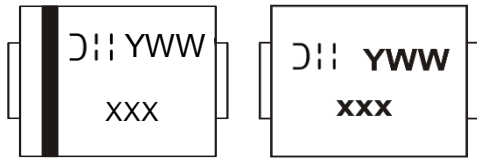

XXX = Product Type Marking Code
 (See Electrical Characteristics Table)
 D; = Manufacturer's Marking
 YWW = Date Code Marking
 Y = Last Digit of Year (ex: 2 for 2022)
 WW = Week Code (01 to 53)



Maximum Ratings (@T_A = +25°C, unless otherwise specified.)

| Characteristic | Symbol | Value | Unit |
|--|--------------------|-------|------|
| Peak Pulse Power Dissipation (Non-Repetitive Current Pulse Derated Above T _A = +25°C) (Note 5) | P _{PK} | 1500 | W |
| Peak Forward Surge Current, 8.3ms Single Half Sine-Wave Superimposed on Rated Load (Notes 5, 6, & 7) | I _{FSM} | 200 | A |
| Steady State Power Dissipation @ T _L = +75°C | PM _(AV) | 5.0 | W |
| Instantaneous Forward Voltage @ I _{PP} = 100A (Notes 5 & 7) | V _F | 3.5 | V |

Thermal Characteristics

| Characteristic | Symbol | Value | Unit |
|-----------------------------|------------------|-------------|------|
| Operating Temperature Range | T _J | -55 to +150 | °C |
| Storage Temperature Range | T _{STG} | -55 to +175 | °C |

Notes:

5. Valid provided that terminals are kept at ambient temperature.
6. Measured with 8.3ms single half sine-wave. Duty cycle = 4 pulses per minute maximum.
7. Unidirectional units only.

Electrical Characteristics (@T_A = +25°C, unless otherwise specified.)

| Part Number Add C For Bidirectional (Note 8) | Reverse Standoff Voltage V _{RWM} (V) | Breakdown Voltage V _{BR} @ I _T (Note 9) | | Test Current I _T (mA) | Max. Reverse Leakage @ V _{RWM} (Note 10) I _R (μA) | Max. Clamping Voltage @ I _{PP} (Note 11) V _C (V) | Max. Peak Pulse Current I _{PP} (A) | Marking Code | |
|---|--|---|---------|--|--|---|---|--------------|-----|
| | | Min (V) | Max (V) | | | | | BI | UNI |
| SMCJ5.0(C)AQ | 5.0 | 6.40 | 7.07 | 10 | 1000 | 9.2 | 163.0 | BDE | GDE |
| SMCJ6.0(C)AQ | 6.0 | 6.67 | 7.37 | 10 | 1000 | 10.3 | 145.6 | BDG | GDG |
| SMCJ6.5(C)AQ | 6.5 | 7.22 | 7.98 | 10 | 500 | 11.2 | 133.9 | BDK | GDK |
| SMCJ7.0(C)AQ | 7.0 | 7.78 | 8.60 | 10 | 200 | 12.0 | 125.0 | BDM | GDM |
| SMCJ7.5(C)AQ | 7.5 | 8.33 | 9.21 | 1.0 | 100 | 12.9 | 116.3 | BDP | GDP |
| SMCJ8.0(C)AQ | 8.0 | 8.89 | 9.83 | 1.0 | 50 | 13.6 | 110.3 | BDR | GDR |
| SMCJ8.5(C)AQ | 8.5 | 9.44 | 10.4 | 1.0 | 20 | 14.4 | 104.2 | BDT | GDT |
| SMCJ9.0(C)AQ | 9.0 | 10.00 | 11.1 | 1.0 | 10 | 15.4 | 97.4 | BDV | GDV |
| SMCJ10(C)AQ | 10.0 | 11.10 | 12.3 | 1.0 | 5.0 | 17.0 | 88.2 | BDX | GDX |
| SMCJ11(C)AQ | 11.0 | 12.20 | 13.5 | 1.0 | 5.0 | 18.2 | 82.4 | BDZ | GDZ |
| SMCJ12(C)AQ | 12.0 | 13.30 | 14.7 | 1.0 | 5.0 | 19.9 | 75.3 | BEE | GEE |
| SMCJ13(C)AQ | 13.0 | 14.40 | 15.9 | 1.0 | 5.0 | 21.5 | 69.7 | BEG | GEG |
| SMCJ14(C)AQ | 14.0 | 15.60 | 17.2 | 1.0 | 5.0 | 23.2 | 64.7 | BEK | GEK |
| SMCJ15(C)AQ | 15.0 | 16.70 | 18.5 | 1.0 | 5.0 | 24.4 | 61.5 | BEM | GEM |
| SMCJ16(C)AQ | 16.0 | 17.80 | 19.7 | 1.0 | 5.0 | 26.0 | 57.7 | BEP | GEP |
| SMCJ17(C)AQ | 17.0 | 18.90 | 20.9 | 1.0 | 5.0 | 27.6 | 53.3 | BER | GER |
| SMCJ18(C)AQ | 18.0 | 20.00 | 22.1 | 1.0 | 5.0 | 29.2 | 51.4 | BET | GET |
| SMCJ20(C)AQ | 20.0 | 22.20 | 24.5 | 1.0 | 5.0 | 32.4 | 46.3 | BEV | GEV |
| SMCJ22(C)AQ | 22.0 | 24.40 | 27.0 | 1.0 | 5.0 | 35.5 | 42.2 | BEX | GEX |
| SMCJ24(C)AQ | 24.0 | 26.70 | 29.5 | 1.0 | 5.0 | 38.9 | 38.6 | BEZ | GEZ |
| SMCJ26(C)AQ | 26.0 | 28.90 | 31.9 | 1.0 | 5.0 | 42.1 | 35.6 | BFE | GFE |
| SMCJ28(C)AQ | 28.0 | 31.10 | 34.4 | 1.0 | 5.0 | 45.4 | 33.0 | BFG | GFG |
| SMCJ30(C)AQ | 30.0 | 33.30 | 36.8 | 1.0 | 5.0 | 48.4 | 31.0 | BFK | GFK |
| SMCJ33(C)AQ | 33.0 | 36.70 | 40.6 | 1.0 | 5.0 | 53.3 | 28.1 | BFM | GFM |
| SMCJ36(C)AQ | 36.0 | 40.00 | 44.2 | 1.0 | 5.0 | 58.1 | 25.8 | BFP | GFP |
| SMCJ40(C)AQ | 40.0 | 44.40 | 49.1 | 1.0 | 5.0 | 64.5 | 23.2 | BFR | GFR |
| SMCJ48(C)AQ | 48.0 | 53.30 | 58.9 | 1.0 | 5.0 | 77.4 | 19.4 | BFX | GFX |
| SMCJ51(C)AQ | 51.0 | 56.70 | 62.7 | 1.0 | 5.0 | 82.4 | 18.2 | BFZ | GFZ |
| SMCJ58(C)AQ | 58.0 | 64.40 | 71.2 | 1.0 | 5.0 | 93.6 | 16.0 | BGG | GGG |
| SMCJ60(C)AQ | 60.0 | 66.70 | 73.7 | 1.0 | 5.0 | 96.8 | 15.5 | BGK | GGK |
| SMCJ64(C)AQ | 64.0 | 71.10 | 78.6 | 1.0 | 5.0 | 103.0 | 14.6 | BGM | GGM |
| SMCJ70(C)AQ | 70.0 | 77.80 | 86.0 | 1.0 | 5.0 | 113.0 | 13.3 | BGP | GGP |
| SMCJ75(C)AQ | 75.0 | 83.30 | 92.1 | 1.0 | 5.0 | 121.0 | 12.4 | BGR | GGR |
| SMCJ78(C)AQ | 78.0 | 86.70 | 95.8 | 1.0 | 5.0 | 126.0 | 11.4 | BGT | GGT |
| SMCJ85(C)AQ | 85.0 | 94.40 | 104 | 1.0 | 5.0 | 137.0 | 10.4 | BGV | GGV |
| SMCJ110(C)AQ | 110.0 | 122.00 | 135 | 1.0 | 5.0 | 177.0 | 8.4 | BHE | GHE |

- Notes:
8. Suffix C denotes bidirectional device.
 9. V_{BR} measured with I_T current pulse = 10ms to 15ms.
 10. For bidirectional devices having V_{RWM} of 10V and under, the I_R is doubled.
 11. Per 10 x 1000μs waveform. See Fig 4.



Fig. 1 Pulse Derating Curve

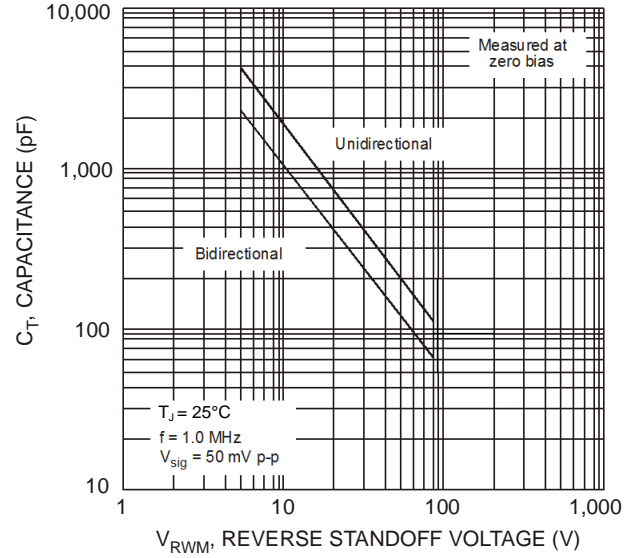

Fig. 2 Typical Total Capacitance



Fig. 3 Pulse Rating Curve

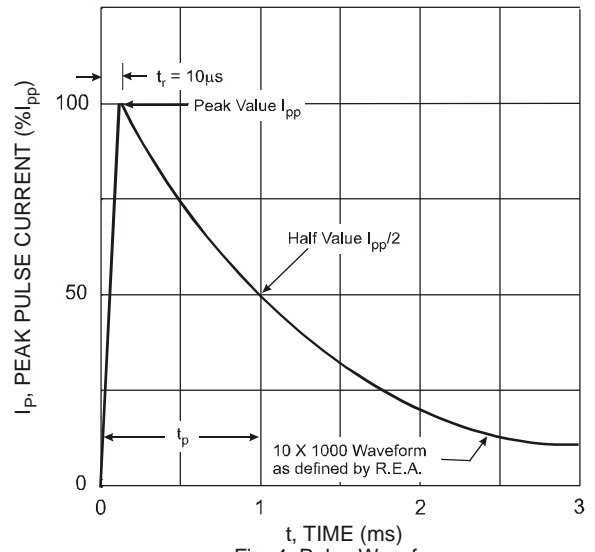

Fig. 4 Pulse Waveform



Fig. 5 Maximum Non-Repetitive Surge Current

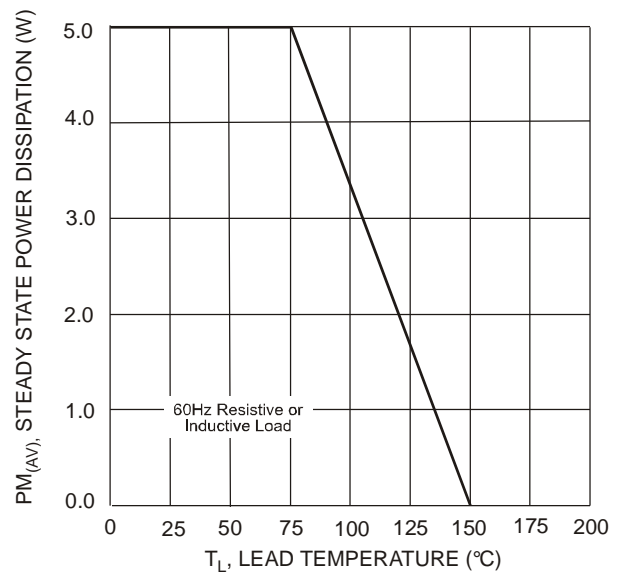
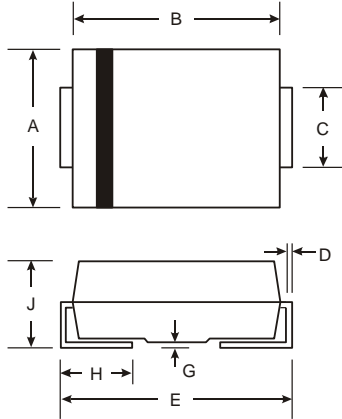

Fig. 6 Steady State Power Derating Curve

Package Outline Dimensions

Please see <http://www.diodes.com/package-outlines.html> for the latest version.

SMC



| SMC | | |
|----------------------|------|------|
| Dim | Min | Max |
| A | 5.59 | 6.22 |
| B | 6.60 | 7.11 |
| C | 2.75 | 3.18 |
| D | 0.15 | 0.31 |
| E | 7.75 | 8.13 |
| G | 0.10 | 0.20 |
| H | 0.76 | 1.52 |
| J | 2.00 | 2.50 |
| All Dimensions in mm | | |

Suggested Pad Layout

Please see <http://www.diodes.com/package-outlines.html> for the latest version.

SMC

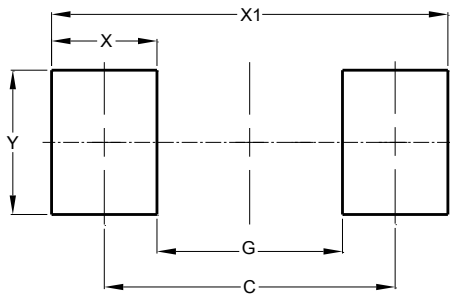

| Dimensions | Value (in mm) |
|------------|---------------|
| C | 6.90 |
| G | 4.40 |
| X | 2.50 |
| X1 | 9.40 |
| Y | 3.30 |

IMPORTANT NOTICE



1. DIODES INCORPORATED (Diodes) AND ITS SUBSIDIARIES MAKE NO WARRANTY OF ANY KIND, EXPRESS OR IMPLIED, WITH REGARDS TO ANY INFORMATION CONTAINED IN THIS DOCUMENT, INCLUDING, BUT NOT LIMITED TO, THE IMPLIED WARRANTIES OF MERCHANTABILITY, FITNESS FOR A PARTICULAR PURPOSE OR NON-INFRINGEMENT OF THIRD PARTY INTELLECTUAL PROPERTY RIGHTS (AND THEIR EQUIVALENTS UNDER THE LAWS OF ANY JURISDICTION).
2. The Information contained herein is for informational purpose only and is provided only to illustrate the operation of Diodes' products described herein and application examples. Diodes does not assume any liability arising out of the application or use of this document or any product described herein. This document is intended for skilled and technically trained engineering customers and users who design with Diodes' products. Diodes' products may be used to facilitate safety-related applications; however, in all instances customers and users are responsible for (a) selecting the appropriate Diodes products for their applications, (b) evaluating the suitability of Diodes' products for their intended applications, (c) ensuring their applications, which incorporate Diodes' products, comply the applicable legal and regulatory requirements as well as safety and functional-safety related standards, and (d) ensuring they design with appropriate safeguards (including testing, validation, quality control techniques, redundancy, malfunction prevention, and appropriate treatment for aging degradation) to minimize the risks associated with their applications.
3. Diodes assumes no liability for any application-related information, support, assistance or feedback that may be provided by Diodes from time to time. Any customer or user of this document or products described herein will assume all risks and liabilities associated with such use, and will hold Diodes and all companies whose products are represented herein or on Diodes' websites, harmless against all damages and liabilities.
4. Products described herein may be covered by one or more United States, international or foreign patents and pending patent applications. Product names and markings noted herein may also be covered by one or more United States, international or foreign trademarks and trademark applications. Diodes does not convey any license under any of its intellectual property rights or the rights of any third parties (including third parties whose products and services may be described in this document or on Diodes' website) under this document.
5. Diodes' products are provided subject to Diodes' Standard Terms and Conditions of Sale (<https://www.diodes.com/about/company/terms-and-conditions/terms-and-conditions-of-sales/>) or other applicable terms. This document does not alter or expand the applicable warranties provided by Diodes. Diodes does not warrant or accept any liability whatsoever in respect of any products purchased through unauthorized sales channel.
6. Diodes' products and technology may not be used for or incorporated into any products or systems whose manufacture, use or sale is prohibited under any applicable laws and regulations. Should customers or users use Diodes' products in contravention of any applicable laws or regulations, or for any unintended or unauthorized application, customers and users will (a) be solely responsible for any damages, losses or penalties arising in connection therewith or as a result thereof, and (b) indemnify and hold Diodes and its representatives and agents harmless against any and all claims, damages, expenses, and attorney fees arising out of, directly or indirectly, any claim relating to any noncompliance with the applicable laws and regulations, as well as any unintended or unauthorized application.
7. While efforts have been made to ensure the information contained in this document is accurate, complete and current, it may contain technical inaccuracies, omissions and typographical errors. Diodes does not warrant that information contained in this document is error-free and Diodes is under no obligation to update or otherwise correct this information. Notwithstanding the foregoing, Diodes reserves the right to make modifications, enhancements, improvements, corrections or other changes without further notice to this document and any product described herein. This document is written in English but may be translated into multiple languages for reference. Only the English version of this document is the final and determinative format released by Diodes.
8. Any unauthorized copying, modification, distribution, transmission, display or other use of this document (or any portion hereof) is prohibited. Diodes assumes no responsibility for any losses incurred by the customers or users or any third parties arising from any such unauthorized use.
9. This Notice may be periodically updated with the most recent version available at <https://www.diodes.com/about/company/terms-and-conditions/important-notice>

DIODES is a trademark of Diodes Incorporated in the United States and other countries.
The Diodes logo is a registered trademark of Diodes Incorporated in the United States and other countries.
© 2022 Diodes Incorporated. All Rights Reserved.

www.diodes.com

Looking for pricing, stock, or lifecycle information?

Click below to explore more details on WIN SOURCE:

-  [View SMCJ28CAQ-13-F on WIN SOURCE](#)
-  [Diodes Incorporated Information](#)

Optimize Your Supply Chain with WIN SOURCE Solutions

-  Global Sourcing Solution
-  Obsolete Management
-  Cost Control Management
-  Shortage Management
-  Alternative Solution
-  Excess Inventory Management