



**THE DATASHEET OF
SIT9120AI-1B2-33E25.000000**



SNx4AHCT240 Octal Inverting Buffers/Drivers With Tri-State Outputs

1 Features

- Inputs are TTL-Voltage Compatible
- Latch-Up Performance Exceeds 250 mA Per JESD 17
- On Products Compliant to MIL-PRF-38535, All Parameters Are Tested Unless Otherwise Noted. On All Other Products, Production Processing Does Not Necessarily Include Testing of All Parameters.

2 Applications

- Network Switches
- Health and Fitness
- Televisions
- Power Infrastructures

3 Description

The SNx4AHCT240 octal buffers/drivers are designed specifically to improve both the performance and density of tri-state memory-address drivers, clock drivers, and bus-oriented receivers and transmitters.

Device Information⁽¹⁾

PART NUMBER	PACKAGE	BODY SIZE (NOM)
SN74AHCT240DB	SSOP (20)	7.50 mm x 5.30 mm
SN74AHCT240NS	SO (20)	12.60 mm x 5.30 mm
SN74AHCT240PW	TSSOP (20)	6.50 mm x 4.40 mm
SN74AHCT240DW	SOIC (20)	12.80 mm x 7.50 mm
SN74AHCT240N	PDIP (20)	25.40 mm x 6.35 mm

(1) For all available packages, see the orderable addendum at the end of the data sheet.

Simplified Schematic

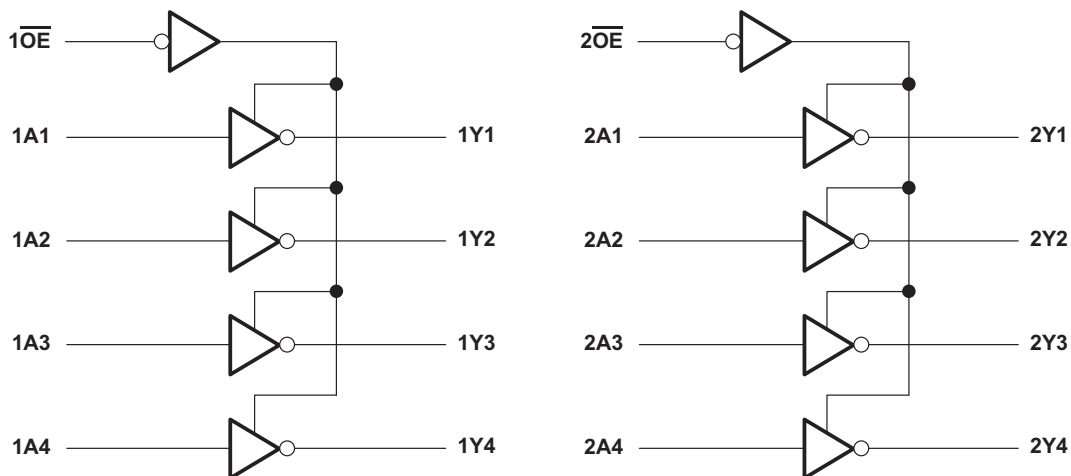

Copyright © 2016, Texas Instruments Incorporated



Table of Contents

1	Features	1	9.2	Functional Block Diagram	10
2	Applications	1	9.3	Feature Description	10
3	Description	1	9.4	Device Functional Modes	10
4	Revision History	2	10	Application and Implementation	11
5	Pin Configuration and Functions	3	10.1	Application Information	11
6	Specifications	4	10.2	Typical Application	11
6.1	Absolute Maximum Ratings	4	11	Power Supply Recommendations	12
6.2	ESD Ratings	4	12	Layout	12
6.3	Recommended Operating Conditions	5	12.1	Layout Guidelines	12
6.4	Thermal Information	5	12.2	Layout Example	12
6.5	Electrical Characteristics	5	13	Device and Documentation Support	13
6.6	Switching Characteristics	6	13.1	Community Resources	13
6.7	Noise Characteristics	6	13.2	Related Links	13
6.8	Operating Characteristics	6	13.3	Trademarks	13
7	Typical Characteristics	7	13.4	Electrostatic Discharge Caution	13
8	Parameter Measurement Information	8	13.5	Glossary	13
9	Detailed Description	10	14	Mechanical, Packaging, and Orderable Information	13
9.1	Overview	10			

4 Revision History

Changes from Revision M (April 2016) to Revision N	Page
• Added junction temperature to <i>Absolute Maximum Ratings</i> table	4
• Moved storage temperature from <i>ESD Ratings</i> table to <i>Absolute Maximum Ratings</i> table	4
• Changed the <i>Function</i> table layout	10

Changes from Revision L (October 2014) to Revision M	Page
• Changed <i>Handling Ratings</i> table title to <i>ESD Ratings</i>	4
• Added –40°C to 85°C to SN74AHCT240 header in <i>Electrical Characteristics</i> table	5
• Added –40°C to 85°C to SN74AHCT240 header in <i>Switching Characteristics</i> table	6

Changes from Revision K (July 2003) to Revision L	Page
• Updated document to new TI data sheet format	1
• Deleted Ordering Information table	1
• Added Military Disclaimer to Features list	1
• Added Applications	1
• Extended operating temperature range to 125°C	5
• Added <i>Thermal Information</i> table	5
• Added –40°C to 125°C for SN74AHCT240 in the Electrical Specifications table	5
• Added –40°C to 125°C for SN74AHCT240 in the Switching Characteristics table	6
• Added Detailed Description section	10
• Added <i>Application and Implementation</i> section	11
• Added Power Supply Recommendations and Layout sections	12

5 Pin Configuration and Functions

SN54AHCT240, J or W Package
SN74AHCT240, DB, DGV, DW, N, NS, or PW Package (20) Pin
Top View

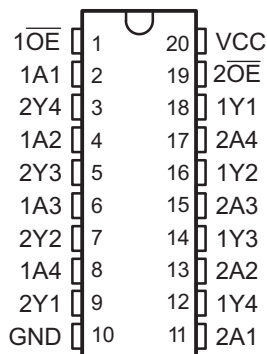

SN54AHCT240 FK Package (20) Pin
Top View

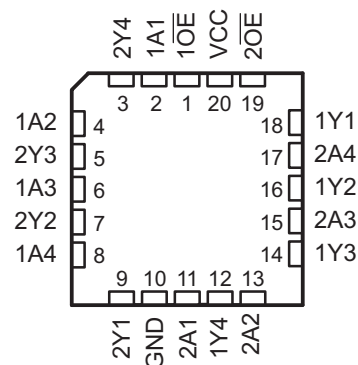

Pin Functions

PIN		I/O	DESCRIPTION
NAME	NO.		
$\overline{1OE}$	1	I	Output Enable 1
1A1	2	I	1A1 Input
2Y4	3	O	2Y4 Output
1A2	4	I	1A2 Input
2Y3	5	O	2Y3 Output
1A3	6	I	1A3 Input
2Y2	7	O	2Y2 Output
1A4	8	I	1A4 Input
2Y1	9	O	2Y1 Output
GND	10	—	Ground Pin
2A1	11	I	2A1 Input
1Y4	12	O	1Y4 Output
2A2	13	I	2A2 Input
1Y3	14	O	1Y3 Output
2A3	15	I	2A3 Input
1Y2	16	O	1Y2 Output
2A4	17	I	2A4 Input
1Y1	18	O	1Y1 Output
$\overline{2OE}$	19	I	Output Enable 2
VCC	20	—	Power Pin

6 Specifications

6.1 Absolute Maximum Ratings

over operating free-air temperature range (unless otherwise noted)⁽¹⁾

		MIN	MAX	UNIT
Supply voltage, V_{CC}		-0.5	7	V
Input voltage, V_I ⁽²⁾		-0.5	7	V
Output voltage, V_O ⁽²⁾		-0.5	$V_{CC} + 0.5$	V
Input clamp current, I_{IK}	$V_I < 0$		-20	mA
Output clamp current, I_{OK}	$V_O < 0$ or $V_O > V_{CC}$		± 20	mA
Continuous output current, I_O	$V_O = 0$ to V_{CC}		± 25	mA
Continuous current through V_{CC} or GND			± 75	mA
Junction temperature, T_J			150	°C
Storage temperature, T_{stg}		-65	150	°C

- (1) Stresses beyond those listed under *Absolute Maximum Ratings* may cause permanent damage to the device. These are stress ratings only, which do not imply functional operation of the device at these or any other conditions beyond those indicated under *Recommended Operating Conditions*. Exposure to absolute-maximum-rated conditions for extended periods may affect device reliability.
- (2) The input and output voltage ratings may be exceeded if the input and output current ratings are observed.

6.2 ESD Ratings

		MIN	MAX	UNIT
$V_{(ESD)}$ Electrostatic discharge	Human body model (HBM), per ANSI/ESDA/JEDEC JS-001, all pins ⁽¹⁾	0	1000	V
	Charged device model (CDM), per JEDEC specification JESD22-C101, all pins ⁽²⁾	0	2000	

- (1) JEDEC document JEP155 states that 500-V HBM allows safe manufacturing with a standard ESD control process.
- (2) JEDEC document JEP157 states that 250-V CDM allows safe manufacturing with a standard ESD control process.

6.3 Recommended Operating Conditions

 over operating free-air temperature range (unless otherwise noted)⁽¹⁾

		SN54AHCT240		SN74AHCT240		UNIT
		MIN	MAX	MIN	MAX	
V _{CC}	Supply voltage	4.5	5.5	4.5	5.5	V
V _{IH}	High-level input voltage	2		2		V
V _{IL}	Low-level Input voltage		0.8		0.8	V
V _I	Input voltage	0	5.5	0	5.5	V
V _O	Output voltage	0	V _{CC}	0	V _{CC}	V
I _{OH}	High-level output current		-8		-8	mA
I _{OL}	Low-level output current		8		8	mA
T _A	Operating free-air temperature	-55	125	-40	125	°C

(1) All unused inputs of the device must be held at V_{CC} or GND to ensure proper device operation. See the [Implications of Slow or Floating CMOS Inputs application report](#).

6.4 Thermal Information

THERMAL METRIC ⁽¹⁾		SN74AHCT240					UNIT
		DW	DB	N	NS	PW	
		20 PINS	20 PINS	20 PINS	20 PINS	20 PINS	
R _{θJA}	Junction-to-ambient thermal resistance	83.0	99.9	54.9	80.4	105.4	°C/W
R _{θJC(top)}	Junction-to-case (top) thermal resistance	48.9	61.7	41.7	46.9	39.5	
R _{θJB}	Junction-to-board thermal resistance	50.5	55.2	35.8	47.9	56.4	
ψ _{JT}	Junction-to-top characterization parameter	21.1	22.6	27.9	19.9	3.1	
ψ _{JB}	Junction-to-board characterization parameter	50.1	54.8	35.7	47.5	55.8	

(1) For more information about traditional and new thermal metrics, see the [IC Package Thermal Metrics application report](#).

6.5 Electrical Characteristics

over recommended operating free-air temperature range (unless otherwise noted)

PARAMETER	TEST CONDITIONS	T _A = 25°C			SN54AHCT240		-40°C to 85°C SN74AHCT240		-40°C to 125°C SN74AHCT240		UNIT
		MIN	TYP	MAX	MIN	MAX	MIN	MAX	MIN	MAX	
V _{OH}	High-level output voltage	I _{OH} = -50 μA, V _{CC} = 4.5 V	4.4	4.5	4.4		4.4		4.4		V
		I _{OH} = -8 mA, V _{CC} = 4.5 V	3.94		3.8		3.8		3.8		
V _{OL}	Low-level output voltage	I _{OL} = 50 μA, V _{CC} = 4.5 V			0.1		0.1		0.1		V
		I _{OL} = 8 mA, V _{CC} = 4.5 V			0.36		0.44		0.44		
I _{OZ}	High-impedance-state output current	V _O = V _{CC} or GND V _{CC} = 5.5 V			±0.25		±2.5		±2.5		μA
I _I	Inflection-point current	V _I = 5.5 V or GND V _{CC} = 0 V to 5.5 V			±0.1		±1 ⁽¹⁾		±1		μA
I _{CC}	Supply current	V _I = V _{CC} or GND I _O = 0, V _{CC} = 5.5 V			4		40		40		μA
ΔI _{CC} ⁽²⁾	Supply current change	One input at 3.4 V other inputs at V _{CC} or GND V _{CC} = 5.5 V			1.35		1.5		1.5		mA
C _i	Input capacitance	V _I = V _{CC} or GND V _{CC} = 5.5 V			2.5		10		10		pF
C _o	Output capacitance	V _O = V _{CC} or GND V _{CC} = 5.5 V			3						pF

(1) On products compliant to MIL-PRF-38535, this parameter is not production tested at V_{CC} = 0 V.

(2) This is the increase in supply current for each input at one of the specified TTL voltage levels, rather than 0 V or V_{CC}.

6.6 Switching Characteristics

over recommended operating free-air temperature range, $V_{CC} = 5\text{ V} \pm 0.5\text{ V}$ (unless otherwise noted) (see [Parameter Measurement Information](#) section)

PARAMETER	TEST CONDITIONS		$T_A = 25^\circ\text{C}$		SN54AHCT240		–40°C to 85°C SN74AHCT240		–40°C to 125°C SN74AHCT240		UNIT
			TYP	MAX	MIN	MAX	MIN	MAX	MIN	MAX	
t_{PLH} Propagation delay time (low-to-high output)	A-to-Y	$C_L = 15\text{ pF}$	5.4 ⁽¹⁾	7.4 ⁽¹⁾	1 ⁽¹⁾	8.5 ⁽¹⁾	1	8.5	1	9.5	ns
t_{PHL} Propagation delay time (high-to-low output)			5.4 ⁽¹⁾	7.4 ⁽¹⁾	1 ⁽¹⁾	8.5 ⁽¹⁾	1	8.5	1	9.5	
t_{PZH} Enable time (to the high level)	\overline{OE} -to-Y	$C_L = 15\text{ pF}$	7.7 ⁽¹⁾	10.4 ⁽¹⁾	1 ⁽¹⁾	12 ⁽¹⁾	1	12	1	13	ns
t_{PZL} Enable time (to the low level)			7.7 ⁽¹⁾	10.4 ⁽¹⁾	1 ⁽¹⁾	12 ⁽¹⁾	1	12	1	13	
t_{PHZ} Disable time (from high level)	\overline{OE} -to-Y	$C_L = 15\text{ pF}$	8.3 ⁽¹⁾	10.4 ⁽¹⁾	1 ⁽¹⁾	12 ⁽¹⁾	1	12	1	13	ns
t_{PLZ} Disable time (from low level)			8.3 ⁽¹⁾	10.4 ⁽¹⁾	1 ⁽¹⁾	12 ⁽¹⁾	1	12	1	13	
t_{PLH} Propagation delay time (low-to-high output)	A-to-Y	$C_L = 50\text{ pF}$	5.9	8.4	1	9.5	1	9.5	1	10.5	ns
t_{PHL} Propagation delay time (high-to-low output)			5.9	8.4	1	9.5	1	9.5	1	10.5	
t_{PZH} Enable time (to the high level)	\overline{OE} -to-Y	$C_L = 50\text{ pF}$	8.2	11.4	1	13	1	13	1	14	ns
t_{PZL} Enable time (to the low level)			8.2	11.4	1	13	1	13	1	14	
t_{PHZ} Disable time (from high level)	\overline{OE} -to-Y	$C_L = 50\text{ pF}$	8.8	11.4	1	13	1	13	1	14	ns
t_{PLZ} Disable time (from low level)			8.8	11.4	1	13	1	13	1	14	
$t_{sk(o)}$ Skew (time), output		$C_L = 50\text{ pF}$		1 ⁽²⁾		1		1		1	ns

(1) On products compliant to MIL-PRF-38535, this parameter is not production tested.

(2) On products compliant to MIL-PRF-38535, this parameter does not apply.

6.7 Noise Characteristics

$V_{CC} = 5\text{ V}$, $C_L = 50\text{ pF}$, $T_A = 25^\circ\text{C}$ ⁽¹⁾

PARAMETER	SN74AHCT240			UNIT
	MIN	TYP	MAX	
$V_{OH(V)}$ Quiet output, minimum dynamic V_{OH}		4.1		V
$V_{IH(D)}$ High-level dynamic input voltage	2			V
$V_{IL(D)}$ Low-level dynamic input voltage			0.8	V

(1) Characteristics are for surface-mount packages only.

6.8 Operating Characteristics

$V_{CC} = 5\text{ V}$, $T_A = 25^\circ\text{C}$

PARAMETER	TEST CONDITIONS	TYP	UNIT
C_{pd} Power dissipation capacitance	No load, $f = 1\text{ MHz}$	10	pF

7 Typical Characteristics

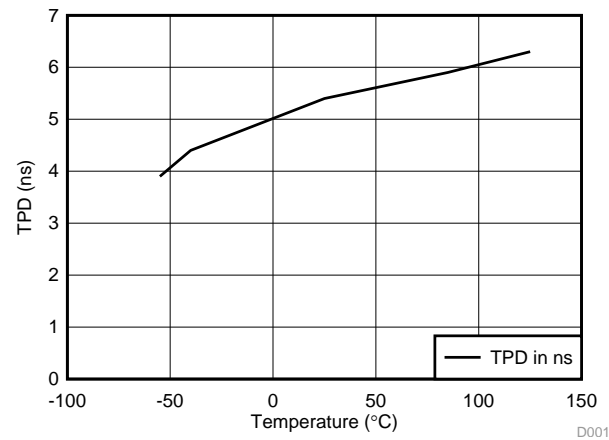

Figure 1. TPD vs Temperature

8 Parameter Measurement Information

Unless otherwise noted, all input pulses are supplied by generators having the following characteristics:

- $PRR \leq 1 \text{ MHz}$
- $Z_O = 50 \Omega$
- $t_r \leq 3 \text{ ns}$
- $t_f \leq 3 \text{ ns}$

NOTE

All parameters and waveforms are not applicable to all devices.

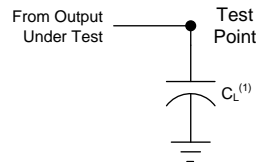

- (1) C_L includes probe and jig capacitance.
- (2) The outputs are measured one at a time, with one transition per measurement.

Figure 2. Load Circuit For Totem-Pole Outputs

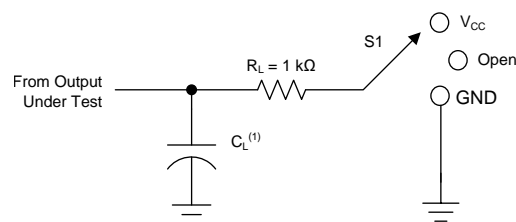

- (1) C_L includes probe and jig capacitance.
- (2) The outputs are measured one at a time, with one transition per measurement.

Figure 3. Load Circuit For Tri-State And Open-Drain Outputs

Table 1. Loading Conditions For Parameter

TEST	S1
$t_{PLH}^{(1)}$, $t_{PHL}^{(1)}$	Open
$t_{PLZ}^{(2)}$, $t_{PZL}^{(3)}$	V_{CC}
$t_{PHZ}^{(2)}$, $t_{PZH}^{(3)}$	GND
Open drain	V_{CC}

- (1) t_{PLH} and t_{PHL} are the same as t_{pd} .
- (2) t_{PLZ} and t_{PHZ} are the same as t_{dis} .
- (3) t_{PZL} and t_{PZH} are the same as t_{en} .

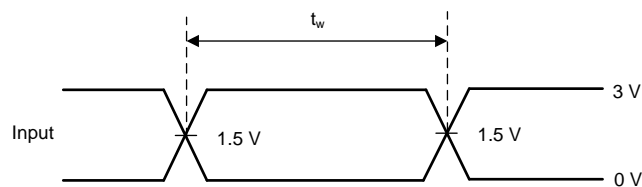
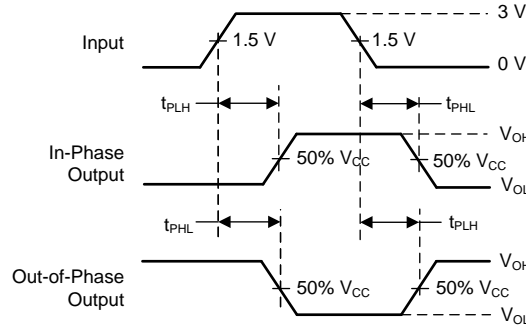

Figure 4. Voltage Waveforms Pulse Durations



(1) The outputs are measured one at a time, with one transition per measurement.

Figure 5. Voltage Waveforms Propagation Delay Times Inverting and Noninverting Outputs

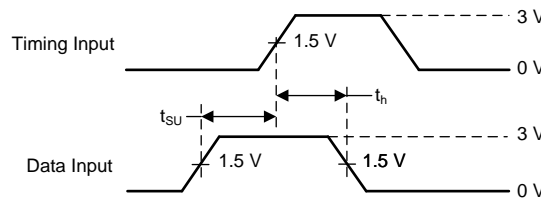
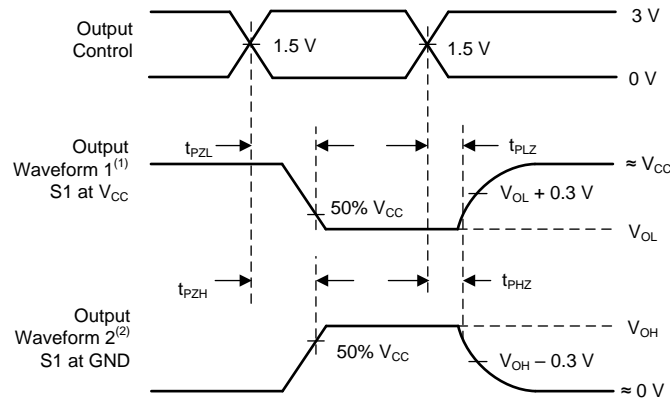

Figure 6. Voltage Waveforms Setup And Hold Times



- (1) Waveform 1 is for an output with internal conditions such that the output is low, except when disabled by the output control.
- (2) Waveform 2 is for an output with internal conditions such that the output is high, except when disabled by the output control.
- (3) The outputs are measured one at a time, with one transition per measurement.

Figure 7. Voltage Waveforms Enable And Disable Times Low- and High-Level Enabling

9 Detailed Description

9.1 Overview

The SN74AHCT240 devices are organized as two 4-bit buffers/line drivers with separate output-enable (\overline{OE}) inputs. When \overline{OE} is low, the device passes inverted data from the A inputs to the Y outputs. When \overline{OE} is high, the outputs are in the high-impedance state. To ensure the high-impedance state during power up or power down, \overline{OE} should be tied to V_{CC} through a pull-up resistor; the minimum value of the resistor is determined by the current-sinking capability of the driver.

9.2 Functional Block Diagram

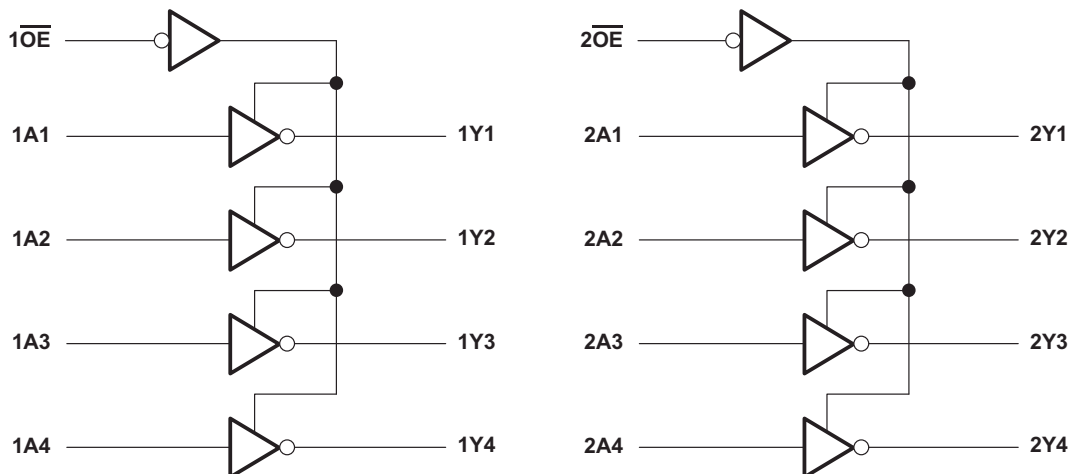

Copyright © 2016, Texas Instruments Incorporated

9.3 Feature Description

- V_{CC} is optimized at 5 V
- Allows up-voltage translation from 3.3 V to 5 V
 - Inputs accept V_{IH} levels of 2 V
- Slow edge rates minimize output ringing
- Inputs are TTL-voltage compatible

9.4 Device Functional Modes

Table 2. Function Table
(Each 4-bit Inverting Buffer/Driver)

INPUTS		OUTPUT Y
\overline{OE}	A	
L	H	L
L	L	H
H	X	Z

10 Application and Implementation

NOTE

Information in the following applications sections is not part of the TI component specification, and TI does not warrant its accuracy or completeness. TI's customers are responsible for determining suitability of components for their purposes. Customers should validate and test their design implementation to confirm system functionality.

10.1 Application Information

The SNx4AHCT240 device is a low-drive CMOS device that may be used for a multitude of bus interface type applications where output ringing is a concern. The low drive and slow edge rates will minimize overshoot and undershoot on the outputs. The input switching levels have been lowered to accommodate TTL inputs of 0.8-V V_{IL} and 2-V V_{IH} . This feature makes the SNx4AHCT240 device ideal for translating up from 3.3 V to 5 V. Figure 8 shows this type of translation.

10.2 Typical Application

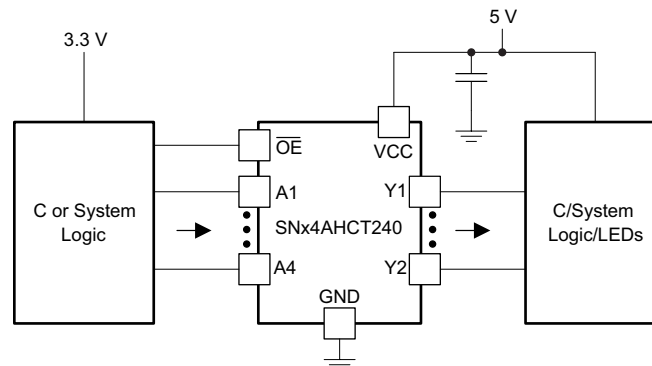

Copyright © 2018, Texas Instruments Incorporated

Figure 8. Application Diagram

10.2.1 Design Requirements

This device uses CMOS technology and has balanced output drive. Care should be taken to avoid bus contention because it can drive currents that would exceed maximum limits. The high drive will also create fast edges into light loads; therefore, routing and load conditions should be considered to prevent ringing.

10.2.2 Detailed Design Procedure

1. Recommended Input Conditions:
 - For rise time and fall time specifications, see $\Delta t/\Delta V$ in the [Recommended Operating Conditions](#) table.
 - For specified high and low levels, see V_{IH} and V_{IL} in the [Recommended Operating Conditions](#) table.
 - Inputs are overvoltage tolerant, allowing them to go as high as 5.5 V at any valid V_{CC} .
2. Recommend Output Conditions:
 - Load currents should not exceed 25 mA per output and 75 mA total for the part.
 - Outputs should not be pulled above V_{CC} .

Typical Application (continued)

10.2.3 Application Curves

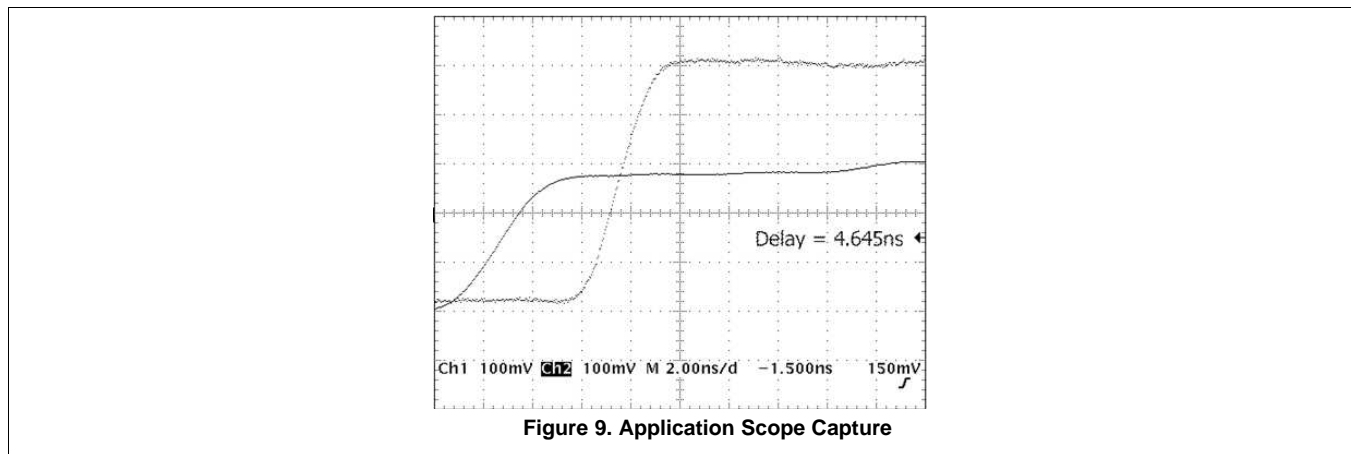

11 Power Supply Recommendations

The power supply can be any voltage between the MIN and MAX supply voltage rating located in the [Recommended Operating Conditions](#).

Each V_{CC} terminal should have a good bypass capacitor to prevent power disturbance. For devices with a single supply, a 0.1 μF capacitor is recommended. If there are multiple V_{CC} terminals then 0.01 μF or 0.022 μF capacitors are recommended for each power terminal. It is ok to parallel multiple bypass capacitors to reject different frequencies of noise. 0.1 μF and 1.0 μF capacitors are commonly used in parallel. The bypass capacitor should be installed as close to the power terminal as possible for the best results.

12 Layout

12.1 Layout Guidelines

When using multiple bit logic devices, inputs should not float. In many cases, functions or parts of functions of digital logic devices are unused. Such examples are when only two inputs of a triple-input AND gate are used, or only 3 of the 4-buffer gates are used. Such input pins should not be left unconnected because the undefined voltages at the outside connections result in undefined operational states.

Specified in [Figure 10](#) are rules that must be observed under all circumstances. All unused inputs of digital logic devices must be connected to a high or low bias to prevent them from floating. The logic level that should be applied to any particular unused input depends on the function of the device. Generally they will be tied to GND or V_{CC} , whichever makes more sense or is more convenient. It is acceptable to float outputs unless the part is a transceiver. If the transceiver has an output enable pin, it will disable the outputs section of the part when asserted. This will not disable the input section of the I/Os so they also cannot float when disabled.

12.2 Layout Example

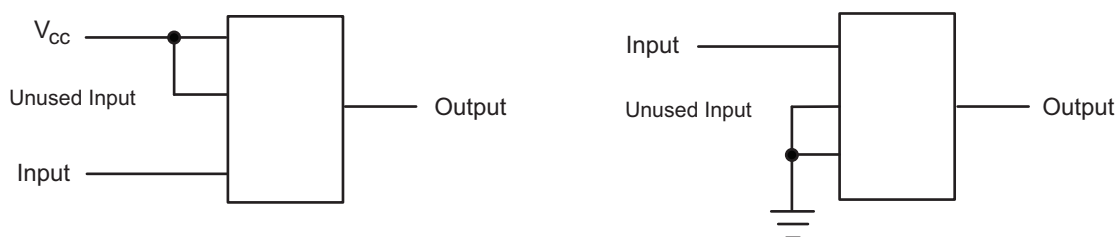

Figure 10. Layout Diagram

13 Device and Documentation Support

13.1 Community Resources

The following links connect to TI community resources. Linked contents are provided "AS IS" by the respective contributors. They do not constitute TI specifications and do not necessarily reflect TI's views; see TI's [Terms of Use](#).

TI E2E™ Online Community *TI's Engineer-to-Engineer (E2E) Community*. Created to foster collaboration among engineers. At e2e.ti.com, you can ask questions, share knowledge, explore ideas and help solve problems with fellow engineers.

Design Support *TI's Design Support* Quickly find helpful E2E forums along with design support tools and contact information for technical support.

13.2 Related Links

The table below lists quick access links. Categories include technical documents, support and community resources, tools and software, and quick access to sample or buy.

Table 3. Related Links

PARTS	PRODUCT FOLDER	SAMPLE & BUY	TECHNICAL DOCUMENTS	TOOLS & SOFTWARE	SUPPORT & COMMUNITY
SN54AHCT240	Click here	Click here	Click here	Click here	Click here
SN74AHCT240	Click here	Click here	Click here	Click here	Click here

13.3 Trademarks

E2E is a trademark of Texas Instruments.
All other trademarks are the property of their respective owners.

13.4 Electrostatic Discharge Caution



These devices have limited built-in ESD protection. The leads should be shorted together or the device placed in conductive foam during storage or handling to prevent electrostatic damage to the MOS gates.

13.5 Glossary

[SLYZ022](#) — *TI Glossary*.

This glossary lists and explains terms, acronyms, and definitions.

14 Mechanical, Packaging, and Orderable Information

The following pages include mechanical, packaging, and orderable information. This information is the most current data available for the designated devices. This data is subject to change without notice and revision of this document. For browser-based versions of this data sheet, refer to the left-hand navigation.

PACKAGING INFORMATION

Orderable Device	Status (1)	Package Type	Package Drawing	Pins	Package Qty	Eco Plan (2)	Lead finish/ Ball material (6)	MSL Peak Temp (3)	Op Temp (°C)	Device Marking (4/5)	Samples
5962-9680601Q2A	ACTIVE	LCCC	FK	20	55	Non-RoHS & Green	SNPB	N / A for Pkg Type	-55 to 125	5962- 9680601Q2A SNJ54AHCT 240FK	Samples
5962-9680601QRA	ACTIVE	CDIP	J	20	20	Non-RoHS & Green	SNPB	N / A for Pkg Type	-55 to 125	5962-9680601QR A SNJ54AHCT240J	Samples
5962-9680601QSA	ACTIVE	CFP	W	20	25	Non-RoHS & Green	SNPB	N / A for Pkg Type	-55 to 125	5962-9680601QS A SNJ54AHCT240W	Samples
SN74AHCT240DBR	ACTIVE	SSOP	DB	20	2000	RoHS & Green	NIPDAU	Level-1-260C-UNLIM	-40 to 125	HB240	Samples
SN74AHCT240DWR	ACTIVE	SOIC	DW	20	2000	RoHS & Green	NIPDAU	Level-1-260C-UNLIM	-40 to 125	AHCT240	Samples
SN74AHCT240N	ACTIVE	PDIP	N	20	20	RoHS & Green	NIPDAU	N / A for Pkg Type	-40 to 125	SN74AHCT240N	Samples
SN74AHCT240NSR	ACTIVE	SO	NS	20	2000	RoHS & Green	NIPDAU	Level-1-260C-UNLIM	-40 to 125	AHCT240	Samples
SN74AHCT240PWR	ACTIVE	TSSOP	PW	20	2000	RoHS & Green	NIPDAU	Level-1-260C-UNLIM	-40 to 125	HB240	Samples
SN74AHCT240PWRG4	ACTIVE	TSSOP	PW	20	2000	RoHS & Green	NIPDAU	Level-1-260C-UNLIM	-40 to 125	HB240	Samples
SNJ54AHCT240FK	ACTIVE	LCCC	FK	20	55	Non-RoHS & Green	SNPB	N / A for Pkg Type	-55 to 125	5962- 9680601Q2A SNJ54AHCT 240FK	Samples
SNJ54AHCT240J	ACTIVE	CDIP	J	20	20	Non-RoHS & Green	SNPB	N / A for Pkg Type	-55 to 125	5962-9680601QR A SNJ54AHCT240J	Samples
SNJ54AHCT240W	ACTIVE	CFP	W	20	25	Non-RoHS & Green	SNPB	N / A for Pkg Type	-55 to 125	5962-9680601QS A SNJ54AHCT240W	Samples

(1) The marketing status values are defined as follows:

ACTIVE: Product device recommended for new designs.

LIFEBUY: TI has announced that the device will be discontinued, and a lifetime-buy period is in effect.

NRND: Not recommended for new designs. Device is in production to support existing customers, but TI does not recommend using this part in a new design.

PREVIEW: Device has been announced but is not in production. Samples may or may not be available.

OBSOLETE: TI has discontinued the production of the device.

(2) **RoHS:** TI defines "RoHS" to mean semiconductor products that are compliant with the current EU RoHS requirements for all 10 RoHS substances, including the requirement that RoHS substance do not exceed 0.1% by weight in homogeneous materials. Where designed to be soldered at high temperatures, "RoHS" products are suitable for use in specified lead-free processes. TI may reference these types of products as "Pb-Free".

RoHS Exempt: TI defines "RoHS Exempt" to mean products that contain lead but are compliant with EU RoHS pursuant to a specific EU RoHS exemption.

Green: TI defines "Green" to mean the content of Chlorine (Cl) and Bromine (Br) based flame retardants meet JS709B low halogen requirements of ≤ 1000 ppm threshold. Antimony trioxide based flame retardants must also meet the ≤ 1000 ppm threshold requirement.

(3) MSL, Peak Temp. - The Moisture Sensitivity Level rating according to the JEDEC industry standard classifications, and peak solder temperature.

(4) There may be additional marking, which relates to the logo, the lot trace code information, or the environmental category on the device.

(5) Multiple Device Markings will be inside parentheses. Only one Device Marking contained in parentheses and separated by a "~" will appear on a device. If a line is indented then it is a continuation of the previous line and the two combined represent the entire Device Marking for that device.

(6) Lead finish/Ball material - Orderable Devices may have multiple material finish options. Finish options are separated by a vertical ruled line. Lead finish/Ball material values may wrap to two lines if the finish value exceeds the maximum column width.

Important Information and Disclaimer:The information provided on this page represents TI's knowledge and belief as of the date that it is provided. TI bases its knowledge and belief on information provided by third parties, and makes no representation or warranty as to the accuracy of such information. Efforts are underway to better integrate information from third parties. TI has taken and continues to take reasonable steps to provide representative and accurate information but may not have conducted destructive testing or chemical analysis on incoming materials and chemicals. TI and TI suppliers consider certain information to be proprietary, and thus CAS numbers and other limited information may not be available for release.

In no event shall TI's liability arising out of such information exceed the total purchase price of the TI part(s) at issue in this document sold by TI to Customer on an annual basis.

OTHER QUALIFIED VERSIONS OF SN54AHCT240, SN74AHCT240 :

- Catalog : [SN74AHCT240](#)

- Automotive : [SN74AHCT240-Q1](#), [SN74AHCT240-Q1](#)

- Military : [SN54AHCT240](#)

NOTE: Qualified Version Definitions:

- Catalog - TI's standard catalog product

- Automotive - Q100 devices qualified for high-reliability automotive applications targeting zero defects
- Military - QML certified for Military and Defense Applications

TAPE AND REEL INFORMATION



QUADRANT ASSIGNMENTS FOR PIN 1 ORIENTATION IN TAPE



*All dimensions are nominal

Device	Package Type	Package Drawing	Pins	SPQ	Reel Diameter (mm)	Reel Width W1 (mm)	A0 (mm)	B0 (mm)	K0 (mm)	P1 (mm)	W (mm)	Pin1 Quadrant
SN74AHCT240DBR	SSOP	DB	20	2000	330.0	16.4	8.2	7.5	2.5	12.0	16.0	Q1
SN74AHCT240DWR	SOIC	DW	20	2000	330.0	24.4	10.8	13.3	2.7	12.0	24.0	Q1
SN74AHCT240NSR	SO	NS	20	2000	330.0	24.4	8.4	13.0	2.5	12.0	24.0	Q1
SN74AHCT240PWR	TSSOP	PW	20	2000	330.0	16.4	6.95	7.0	1.4	8.0	16.0	Q1

TAPE AND REEL BOX DIMENSIONS

*All dimensions are nominal

Device	Package Type	Package Drawing	Pins	SPQ	Length (mm)	Width (mm)	Height (mm)
SN74AHCT240DBR	SSOP	DB	20	2000	356.0	356.0	35.0
SN74AHCT240DWR	SOIC	DW	20	2000	367.0	367.0	45.0
SN74AHCT240NSR	SO	NS	20	2000	367.0	367.0	45.0
SN74AHCT240PWR	TSSOP	PW	20	2000	356.0	356.0	35.0

TUBE

*All dimensions are nominal

Device	Package Name	Package Type	Pins	SPQ	L (mm)	W (mm)	T (μm)	B (mm)
5962-9680601Q2A	FK	LCCC	20	55	506.98	12.06	2030	NA
5962-9680601QSA	W	CFP	20	25	506.98	26.16	6220	NA
SN74AHCT240N	N	PDIP	20	20	506	13.97	11230	4.32
SNJ54AHCT240FK	FK	LCCC	20	55	506.98	12.06	2030	NA
SNJ54AHCT240W	W	CFP	20	25	506.98	26.16	6220	NA

W (R-GDFP-F20)

CERAMIC DUAL FLATPACK



- NOTES:
- A. All linear dimensions are in inches (millimeters).
 - B. This drawing is subject to change without notice.
 - C. This package can be hermetically sealed with a ceramic lid using glass frit.
 - D. Index point is provided on cap for terminal identification only.
 - E. Falls within Mil-Std 1835 GDFP2-F20

PW0020A



PACKAGE OUTLINE

TSSOP - 1.2 mm max height

SMALL OUTLINE PACKAGE



4220206/A 02/2017

NOTES:

1. All linear dimensions are in millimeters. Any dimensions in parenthesis are for reference only. Dimensioning and tolerancing per ASME Y14.5M.
2. This drawing is subject to change without notice.
3. This dimension does not include mold flash, protrusions, or gate burrs. Mold flash, protrusions, or gate burrs shall not exceed 0.15 mm per side.
4. This dimension does not include interlead flash. Interlead flash shall not exceed 0.25 mm per side.
5. Reference JEDEC registration MO-153.

EXAMPLE BOARD LAYOUT

PW0020A

TSSOP - 1.2 mm max height

SMALL OUTLINE PACKAGE



LAND PATTERN EXAMPLE
EXPOSED METAL SHOWN
SCALE: 10X



SOLDER MASK DETAILS

4220206/A 02/2017

NOTES: (continued)

- 6. Publication IPC-7351 may have alternate designs.
- 7. Solder mask tolerances between and around signal pads can vary based on board fabrication site.

EXAMPLE STENCIL DESIGN

PW0020A

TSSOP - 1.2 mm max height

SMALL OUTLINE PACKAGE



SOLDER PASTE EXAMPLE
BASED ON 0.125 mm THICK STENCIL
SCALE: 10X

4220206/A 02/2017

NOTES: (continued)

8. Laser cutting apertures with trapezoidal walls and rounded corners may offer better paste release. IPC-7525 may have alternate design recommendations.
9. Board assembly site may have different recommendations for stencil design.

DB0020A



PACKAGE OUTLINE

SSOP - 2 mm max height

SMALL OUTLINE PACKAGE



4214851/B 08/2019

NOTES:

1. All linear dimensions are in millimeters. Any dimensions in parenthesis are for reference only. Dimensioning and tolerancing per ASME Y14.5M.
2. This drawing is subject to change without notice.
3. This dimension does not include mold flash, protrusions, or gate burrs. Mold flash, protrusions, or gate burrs shall not exceed 0.15 mm per side.
4. This dimension does not include interlead flash. Interlead flash shall not exceed 0.25 mm per side.
5. Reference JEDEC registration MO-150.

EXAMPLE BOARD LAYOUT

DB0020A

SSOP - 2 mm max height

SMALL OUTLINE PACKAGE



LAND PATTERN EXAMPLE
EXPOSED METAL SHOWN
SCALE: 10X

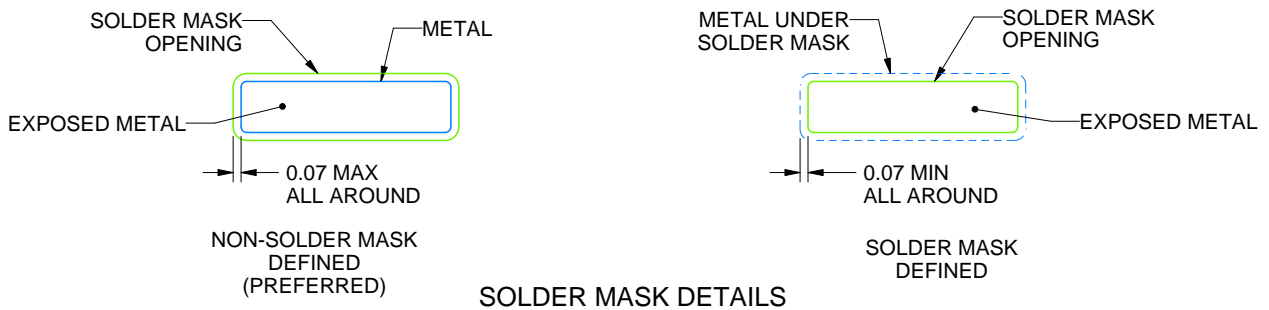

4214851/B 08/2019

NOTES: (continued)

- 6. Publication IPC-7351 may have alternate designs.
- 7. Solder mask tolerances between and around signal pads can vary based on board fabrication site.

EXAMPLE STENCIL DESIGN

DB0020A

SSOP - 2 mm max height

SMALL OUTLINE PACKAGE



SOLDER PASTE EXAMPLE
BASED ON 0.125 mm THICK STENCIL
SCALE: 10X

4214851/B 08/2019

NOTES: (continued)

8. Laser cutting apertures with trapezoidal walls and rounded corners may offer better paste release. IPC-7525 may have alternate design recommendations.
9. Board assembly site may have different recommendations for stencil design.

MECHANICAL DATA

NS (R-PDSO-G**)

PLASTIC SMALL-OUTLINE PACKAGE

14-PINS SHOWN



- NOTES:
- A. All linear dimensions are in millimeters.
 - B. This drawing is subject to change without notice.
 - C. Body dimensions do not include mold flash or protrusion, not to exceed 0,15.

J (R-GDIP-T**)

14 LEADS SHOWN

CERAMIC DUAL IN-LINE PACKAGE



DIM \ PINS **	14	16	18	20
A	0.300 (7,62) BSC	0.300 (7,62) BSC	0.300 (7,62) BSC	0.300 (7,62) BSC
B MAX	0.785 (19,94)	.840 (21,34)	0.960 (24,38)	1.060 (26,92)
B MIN	—	—	—	—
C MAX	0.300 (7,62)	0.300 (7,62)	0.310 (7,87)	0.300 (7,62)
C MIN	0.245 (6,22)	0.245 (6,22)	0.220 (5,59)	0.245 (6,22)



4040083/F 03/03

- NOTES:
- All linear dimensions are in inches (millimeters).
 - This drawing is subject to change without notice.
 - This package is hermetically sealed with a ceramic lid using glass frit.
 - Index point is provided on cap for terminal identification only on press ceramic glass frit seal only.
 - Falls within MIL STD 1835 GDIP1-T14, GDIP1-T16, GDIP1-T18 and GDIP1-T20.

GENERIC PACKAGE VIEW

FK 20

LCCC - 2.03 mm max height

8.89 x 8.89, 1.27 mm pitch

LEADLESS CERAMIC CHIP CARRIER

This image is a representation of the package family, actual package may vary.
Refer to the product data sheet for package details.



4229370VA\

N (R-PDIP-T**)

PLASTIC DUAL-IN-LINE PACKAGE

16 PINS SHOWN



4040049/E 12/2002

- NOTES:
- A. All linear dimensions are in inches (millimeters).
 - B. This drawing is subject to change without notice.
 - $\triangle C$ Falls within JEDEC MS-001, except 18 and 20 pin minimum body length (Dim A).
 - $\triangle D$ The 20 pin end lead shoulder width is a vendor option, either half or full width.

DW0020A



PACKAGE OUTLINE

SOIC - 2.65 mm max height

SOIC



4220724/A 05/2016

NOTES:

1. All linear dimensions are in millimeters. Dimensions in parenthesis are for reference only. Dimensioning and tolerancing per ASME Y14.5M.
2. This drawing is subject to change without notice.
3. This dimension does not include mold flash, protrusions, or gate burrs. Mold flash, protrusions, or gate burrs shall not exceed 0.15 mm per side.
4. This dimension does not include interlead flash. Interlead flash shall not exceed 0.43 mm per side.
5. Reference JEDEC registration MS-013.

EXAMPLE BOARD LAYOUT

DW0020A

SOIC - 2.65 mm max height

SOIC



LAND PATTERN EXAMPLE
SCALE:6X



SOLDER MASK DETAILS

4220724/A 05/2016

NOTES: (continued)

- 6. Publication IPC-7351 may have alternate designs.
- 7. Solder mask tolerances between and around signal pads can vary based on board fabrication site.

EXAMPLE STENCIL DESIGN

DW0020A

SOIC - 2.65 mm max height

SOIC

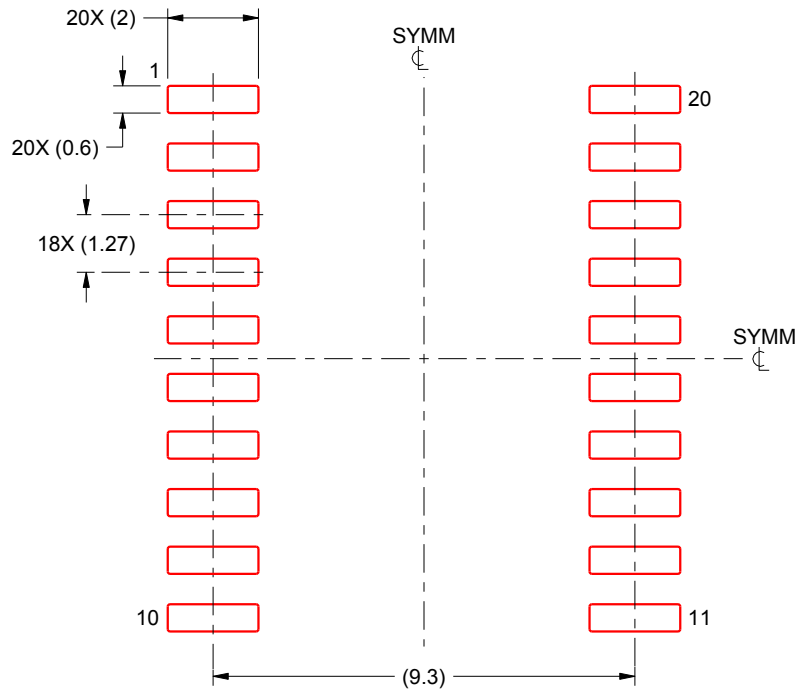

SOLDER PASTE EXAMPLE
BASED ON 0.125 mm THICK STENCIL
SCALE:6X

4220724/A 05/2016

NOTES: (continued)

8. Laser cutting apertures with trapezoidal walls and rounded corners may offer better paste release. IPC-7525 may have alternate design recommendations.
9. Board assembly site may have different recommendations for stencil design.

IMPORTANT NOTICE AND DISCLAIMER

TI PROVIDES TECHNICAL AND RELIABILITY DATA (INCLUDING DATA SHEETS), DESIGN RESOURCES (INCLUDING REFERENCE DESIGNS), APPLICATION OR OTHER DESIGN ADVICE, WEB TOOLS, SAFETY INFORMATION, AND OTHER RESOURCES "AS IS" AND WITH ALL FAULTS, AND DISCLAIMS ALL WARRANTIES, EXPRESS AND IMPLIED, INCLUDING WITHOUT LIMITATION ANY IMPLIED WARRANTIES OF MERCHANTABILITY, FITNESS FOR A PARTICULAR PURPOSE OR NON-INFRINGEMENT OF THIRD PARTY INTELLECTUAL PROPERTY RIGHTS.

These resources are intended for skilled developers designing with TI products. You are solely responsible for (1) selecting the appropriate TI products for your application, (2) designing, validating and testing your application, and (3) ensuring your application meets applicable standards, and any other safety, security, regulatory or other requirements.

These resources are subject to change without notice. TI grants you permission to use these resources only for development of an application that uses the TI products described in the resource. Other reproduction and display of these resources is prohibited. No license is granted to any other TI intellectual property right or to any third party intellectual property right. TI disclaims responsibility for, and you will fully indemnify TI and its representatives against, any claims, damages, costs, losses, and liabilities arising out of your use of these resources.

TI's products are provided subject to [TI's Terms of Sale](#) or other applicable terms available either on [ti.com](https://www.ti.com) or provided in conjunction with such TI products. TI's provision of these resources does not expand or otherwise alter TI's applicable warranties or warranty disclaimers for TI products.

TI objects to and rejects any additional or different terms you may have proposed.

Mailing Address: Texas Instruments, Post Office Box 655303, Dallas, Texas 75265
Copyright © 2024, Texas Instruments Incorporated

Looking for pricing, stock, or lifecycle information?

Click below to explore more details on WIN SOURCE:

 [View SIT9120AI-1B2-33E25.000000 on WIN SOURCE](#)

 [SiTIME Information](#)

Optimize Your Supply Chain with WIN SOURCE Solutions

-  Global Sourcing Solution
-  Obsolete Management
-  Cost Control Management
-  Shortage Management
-  Alternative Solution
-  Excess Inventory Management