



**THE DATASHEET OF  
RO3164E-2**



**RO3164E-1**

**868.35 MHz  
SAW Resonator**

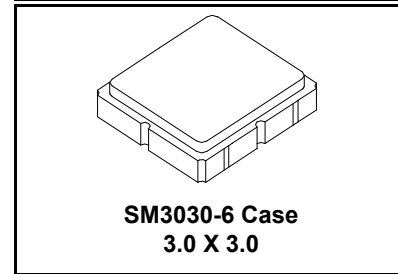

- **Ideal for European 868.35 MHz Transmitters**
- **Very Low Series Resistance**
- **Quartz Stability**
- **Complies with Directive 2002/95/EC (RoHS)**
- **Tape and Reel Standard per ANSI/EIA-481**
- **Moisture Sensitivity Level: 1**
- **AEC-Q200 Qualified**

The RO3164E-1 is a true one-port, surface-acoustic-wave (SAW) resonator in a surface-mount ceramic case. It provides reliable, fundamental-mode, quartz frequency stabilization of fixed-frequency transmitters operating at 868.35 MHz. This SAW is designed specifically for remote-control and wireless security transmitters operating under ETSI-ETS 300 220 in Europe and under FTZ 17 TR 2100 in Germany.

**Absolute Maximum Ratings**

Rating	Value	Units
Input Power Level	0	dBm
DC Voltage	12	VDC
Storage Temperature	-40 to +125	°C
Operating Temperature Range	-40 to +125	°C
Soldering Temperature	+260	°C

**Electrical Characteristics**

Characteristic	Sym	Notes	Minimum	Typical	Maximum	Units
Frequency (+25 °C) Nominal Frequency	$f_C$		868.200		868.500	MHz
Tolerance from 868.35 MHz	$\Delta f_C$				$\pm 150$	kHz
Insertion Loss	IL			1.3	2.0	dB
Quality Factor	$Q_U$	Unloaded Q		7200		
		50 $\Omega$ Loaded Q		975		
Temperature Stability	$T_O$	Turnover Temperature	10	25	40	°C
		Turnover Frequency		$f_C$		kHz
		Frequency Temperature Coefficient	FTC		0.032	
Frequency Aging	fA	Absolute Value during the First Year		< $\pm 10$		ppm/yr
DC Insulation Resistance between Any Two Terminals			1.0			M $\Omega$
RF Equivalent RLC Model	$R_M$	Motional Resistance		16		$\Omega$
		Motional Inductance	$L_M$		20	$\mu$ H
		Motional Capacitance	$C_M$		1.7	fF
		Shunt Static Capacitance	$C_O$		1.6	pF
Test Fixture Shunt Inductance	$L_{TEST}$			20		nH
Lid Symbolization (Y = Year, WW = Week, S = Shift)			773, YWWS			
Standard Reel Quantity	Reel Size 7 Inch		500 Pieces / Reel			
	Reel Size 13 Inch		3000 Pieces / Reel			



**CAUTION: Electrostatic Sensitive Device. Observe precautions for handling.**

**NOTES:**

1. The design, manufacturing process, and specifications of this device are subject to change.
2. US or International patents may apply.
3. RoHS compliant from the first date of manufacture.

**Electrical Connections**

The SAW resonator is bidirectional and may be installed with either orientation. The two terminals are interchangeable and unnumbered. The callout NC indicates no internal connection. The NC pads assist with mechanical positioning and stability. External grounding of the NC pads is recommended to help reduce parasitic capacitance in the circuit.

Pin	Connection
1	NC
2	Terminal
3	NC
4	NC
5	Terminal
6	NC

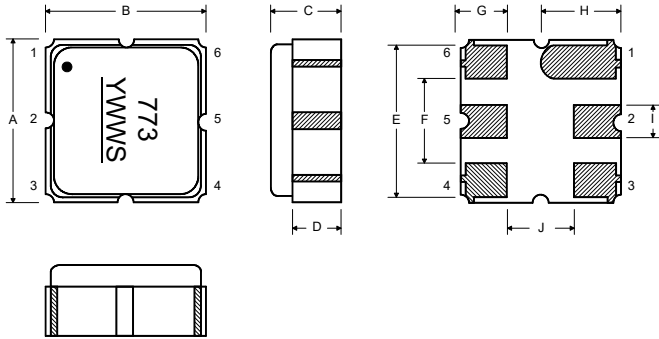

**Case Dimensions**

Dimension	mm			Inches		
	Min	Nom	Max	Min	Nom	Max
A	2.87	3.0	3.13	0.113	0.118	0.123
B	2.87	3.0	3.13	0.113	0.118	0.123
C	1.12	1.25	1.38	0.044	0.049	0.054
D	0.77	0.90	1.03	0.030	0.035	0.040
E	2.67	2.80	2.93	0.105	0.110	0.115
F	1.47	1.6	1.73	0.058	0.063	0.068
G	0.72	0.85	0.98	0.028	0.033	0.038
H	1.37	1.5	1.63	0.054	0.059	0.064
I	0.47	0.60	0.73	0.019	0.024	0.029
J	1.17	1.30	1.43	0.046	0.051	0.056

**Typical Test Circuit**

The test circuit inductor,  $L_{TEST}$ , is tuned to resonate with the static capacitance,  $C_O$ , at  $F_C$ .

**Electrical Test**

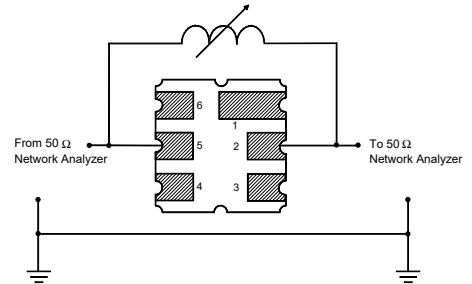

**Power Test**

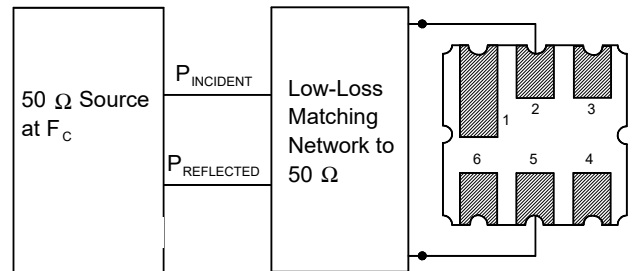

**Typical Application Circuits**

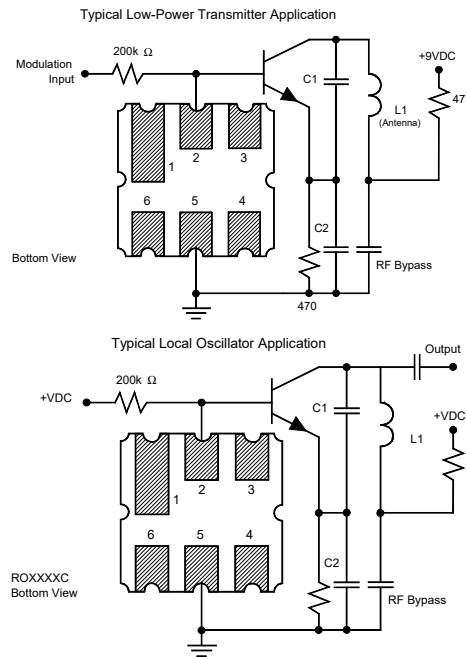

## Equivalent LC Model

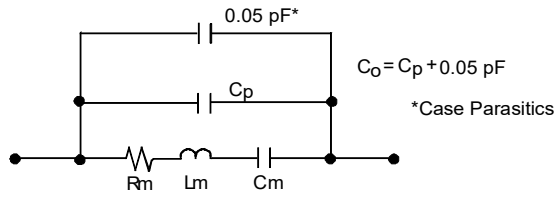

## Temperature Characteristics

The curve shown on the right accounts for resonator contribution only and does not include LC component temperature contributions.

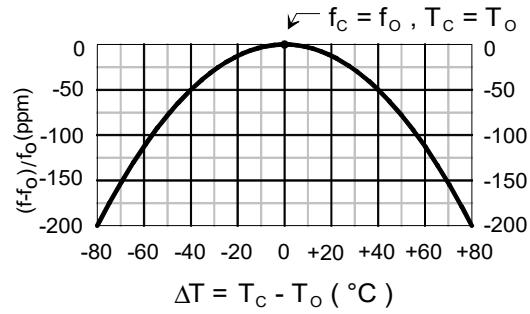

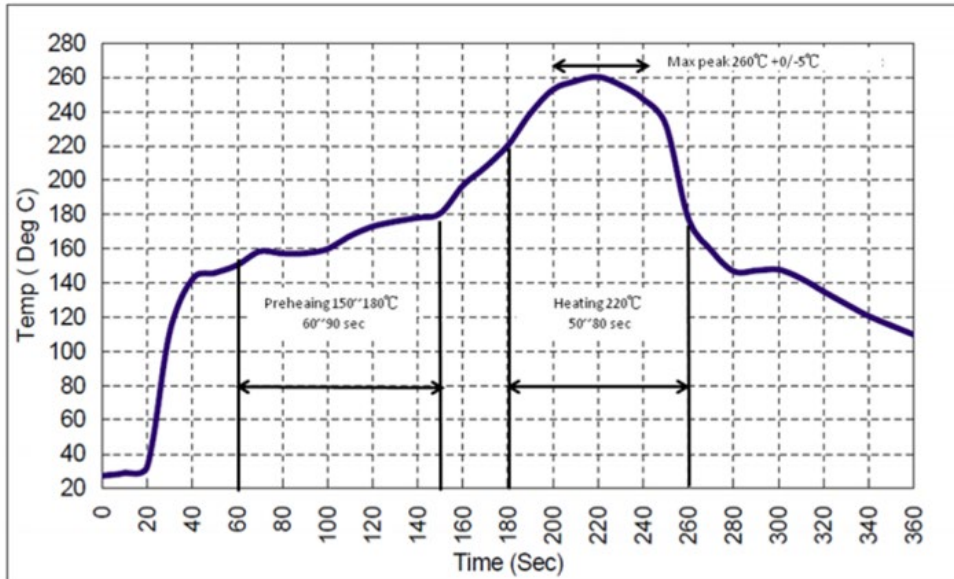

## Recommended Reflow Profile

1. Preheating shall be fixed at 150~180°C for 60~90 seconds.
2. Ascending time to preheating temperature 150°C shall be 30 seconds min.
3. Heating shall be fixed at 220°C for 50~80 seconds and at 260°C +0/-5°C peak (10 seconds).
4. Time: 5 times maximum.



## Looking for pricing, stock, or lifecycle information?

Click below to explore more details on WIN SOURCE:

-  [View RO3164E-2 on WIN SOURCE](#)
-  [RF Monolithics, Inc Information](#)

## Optimize Your Supply Chain with WIN SOURCE Solutions

-  Global Sourcing Solution
-  Obsolete Management
-  Cost Control Management
-  Shortage Management
-  Alternative Solution
-  Excess Inventory Management