



**THE DATASHEET OF  
RI-STU-MRD1-30**



***Series 2000 Reader System***  
***Micro-reader RI-STU-MRD1***

***Reference Guide***

***May 2000***

***TIRIS*** *Technology by  
Texas Instruments™*

# ***Series 2000 Reader System***

***Micro-reader RI-STU-MRD1***

## ***Reference Guide***

***TIRIS*** *Technology by  
Texas Instruments™*

Literature Number: SCBU027  
May 2000



<b>Preface</b> .....	<b>7</b>
<b>1 Product Description</b> .....	<b>9</b>
1.1 General .....	10
1.2 Product Description .....	10
1.2.1 Power Supply .....	11
1.2.2 Antenna .....	11
1.2.3 Synchronization .....	11
1.2.4 Trigger Mode .....	12
1.2.5 Continuous Mode .....	12
1.2.6 Serial Communication .....	12
1.3 Connector Pins .....	13
1.3.1 Pin Connection Description .....	14
1.3.2 Module and Antenna Block Diagrams .....	15
<b>2 Communications Protocol</b> .....	<b>17</b>
2.1 Protocol PC to Micro-reader .....	18
2.1.1 Start Mark .....	18
2.1.2 Length .....	18
2.1.3 Command Field .....	18
2.1.4 Data Field .....	20
2.1.5 BCC .....	20
2.2 Protocol Micro-reader to PC .....	20
2.2.1 Start Mark .....	21
2.2.2 Length .....	21
2.2.3 Status .....	21
2.2.4 Data Field .....	21
2.2.5 BCC .....	21
<b>3 Specifications</b> .....	<b>23</b>
3.1 Recommended Operating Conditions .....	24
3.2 Timings .....	24
3.3 Mechanical Data .....	25
<b>4 Transponder Protocols</b> .....	<b>27</b>
4.1 Transponder Commands .....	28
4.1.1 Read RO, R/W .....	28
4.1.2 Program R/W .....	28
4.1.3 Addressing MPTs/SAMPTs .....	28
4.2 Transponder Responses .....	30
4.2.1 Read Only Transponder .....	30
4.2.2 Read/Write Transponder .....	30
4.2.3 MPT/SAMPT .....	31
<b>5 Communication Protocol Examples</b> .....	<b>33</b>
5.1 PC to Micro-reader .....	34
5.1.1 Read RO, R/W .....	34

---

5.1.2	Program R/W Transponder .....	34
5.1.3	General Read Page of MPT .....	35
5.1.4	Program Page of MPT .....	35
5.1.5	Lock Page of MPT .....	36
5.1.6	Selective Read Page of SAMPT .....	36
5.1.7	Selective Program Page of SAMPT .....	37
5.1.8	Selective Lock Page of SAMPT .....	38
5.2	Micro-reader to PC .....	38
5.2.1	Successful Read of RO.....	38
5.2.2	Successful Program Page 2 of MPT.....	39
5.2.3	No Read .....	39
<b>A</b>	<b>CE Declaration .....</b>	<b>41</b>
<b>B</b>	<b>Demonstration Circuit .....</b>	<b>43</b>
<b>C</b>	<b>Antenna Design .....</b>	<b>45</b>
C.1	Introduction.....	45
C.2	Antenna Construction.....	45
C.3	Q Factor .....	46
C.4	Adapting the Inductance Range .....	46

---

## List of Figures

1-1	Micro-reader Module .....	10
1-2	Micro-reader Pin Connections .....	13
1-3	Block Diagram of the Micro-reader .....	15
1-4	Antenna Circuit Block Diagram .....	16
3-1	Top, Front, and Side Views (Measurements in mm) .....	25
4-1	Read Function .....	28
4-2	Programming Data Format of the 64-bit Read/Write Transponder .....	28
4-3	Data Format of the General Read Page Function .....	29
4-4	Programming Data Format of the MPT.....	29
4-5	Lock Page of MPT/SAMPT .....	29
4-6	Data Format of the Selective Read Page Function .....	29
4-7	Data Format of the Selective Program Page Function .....	30
4-8	Data Format of the Selective Lock Page Function.....	30
4-9	RO Read Data Format.....	30
4-10	R/W Read Data Format .....	30
4-11	MPT/SAMPT Read Data Format .....	31
B-1	Micro-reader Demonstration Circuit.....	43

## List of Tables

1-1	Pin Connections .....	13
-----	-----------------------	----



### **Edition Three - May 2000**

This is the third edition of this manual, it describes the following equipment:

TIRIS™ Micro-reader Module RI-STU-MRD1

### **About This Guide**

This manual describes the TIRIS Micro-reader, its goal is to describe the reader, how it works, how to integrate it and how to use it.

### **Conventions**

#### **WARNING**

**A WARNING IS USED WHERE CARE MUST BE TAKEN, OR A CERTAIN PROCEDURE MUST BE FOLLOWED IN ORDER TO PREVENT INJURY OR HARM TO YOUR HEALTH.**

#### **CAUTION**

This indicates information on conditions which must be met, or a procedure which must be followed, which if not heeded could cause permanent damage to the equipment or software.

---

**Note:** Indicates conditions which must be met, or procedures which must be followed, to ensure proper functioning of the equipment or software.

Also indicates information that makes use of the equipment or software easier.

---

### **If You Need Assistance**

Application Centers are located in Europe, North and South America, the Far East and Australia to provide direct support. For more information, please contact your nearest TIRIS Sales and Application Center. The contact addresses can be found on our home page: <http://www.tiris.com>

### **Trademarks**

The TIRIS logo and the word TIRIS are registered trademarks of Texas Instruments.



## ***Product Description***

---

---

---

This chapter describes the hardware of the Micro-reader. It tells you about the module and how to integrate it.

<b>Topic</b>	<b>Page</b>
<b>1.1 General .....</b>	<b>10</b>
<b>1.2 Product Description .....</b>	<b>10</b>
<b>1.3 Connector Pins .....</b>	<b>13</b>

## 1.1 General

The Micro-reader is an intelligent module providing RF and Control functions to read and program TIRIS transponders. It is equipped with a Serial Communications Interface (SCI) which may be directly connected to commonly used system controllers. The Micro-reader works together with a 47  $\mu$ H, low-Q antenna, and therefore the system does not need tuning.

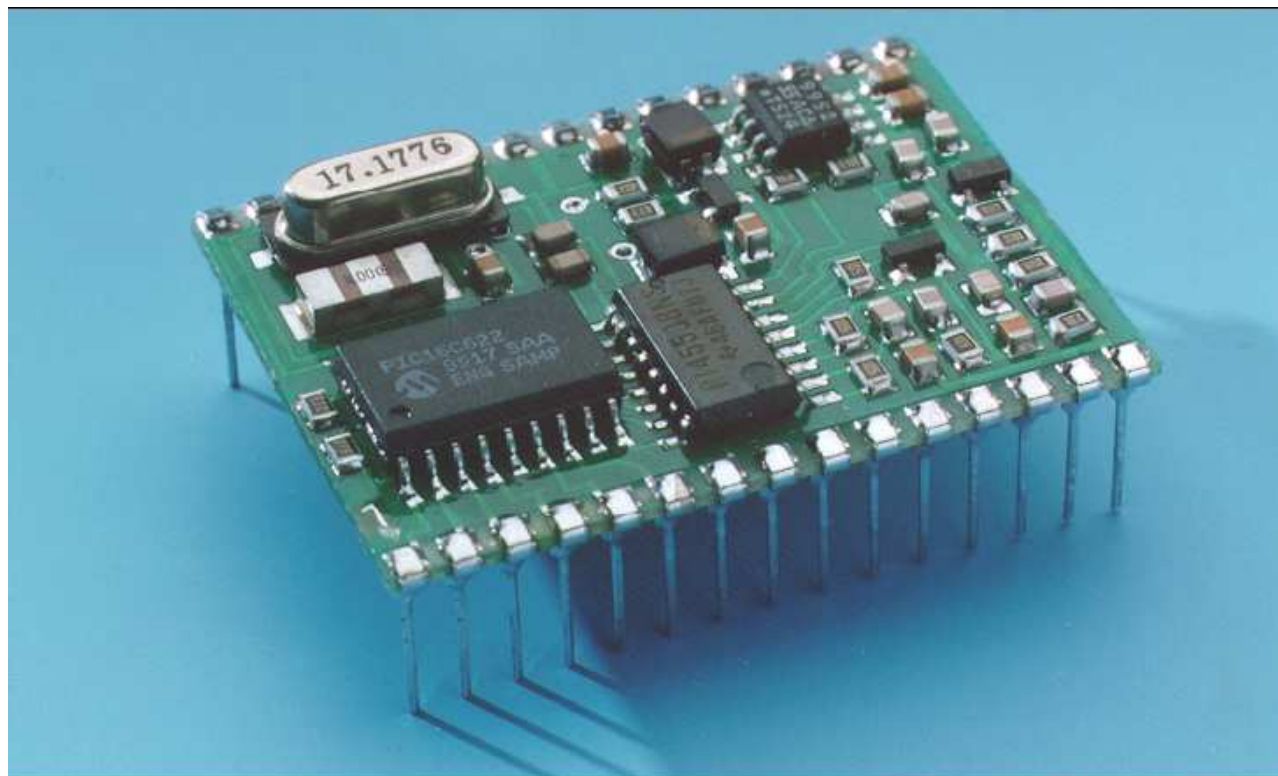

**Figure 1-1. Micro-reader Module**

## 1.2 Product Description

The Micro-reader module is a plug-in module which can be plugged into or soldered onto an application specific adapter board. It supports serial data communications between a PC and TIRIS transponders. With its Serial Communications Interface (SCI) the Micro-reader supports TTL data communications, which with the addition of a communications driver (for example: RS232 or RS422) allows communication to a standard interface.

The Micro-reader can be controlled remotely by either providing certain inputs with the corresponding voltage level or sending commands to the SCI. It can be driven either with or without synchronization - the synchronization can be either wireless or wired to enable reliable operation in multi-reader environments. Two outputs show the reader status and inform the user about a successful command execution. The Micro-reader supports all available TIRIS™ LF transponders.

### 1.2.1 Power Supply

There are two separate 5V supplies to the Micro-reader, one for the output stage (VSP) and the other for the logic (VSL). On power up VSL should rise faster than 0.1 V/ms to ensure a reliable operation. The Micro-reader has an on-board reset circuit which will reset it should the supply fall below 4 V ( $\pm 0.2$  V).

In order to avoid problems with noise conducted via the supply lines, we recommend that if a single supply is used, separate connections from a common de-coupling capacitor are used to feed the Micro-reader.

---

**Note:** The RF Module must not be supplied by Switched Mode Power Supplies (SMPS). This is because most SMPS operate at frequencies around 50 kHz. The harmonics of the generated field can interfere with the TIRIS receiver. Therefore only use linear regulated power supplies, or SMPS with a fundamental operating frequency of 200 kHz or higher.

---

### 1.2.2 Antenna

The Micro-reader has been designed for use with a 47  $\mu$ H antenna with a Q of 10 to 20 to generate the exciter frequency of 134.2 kHz. Because of the low Q the system does not need to be tuned.

**WARNING**  
**CARE MUST BE TAKEN WHEN HANDLING THE MICRO-READER  
AS HIGH VOLTAGES ACROSS THE ANTENNA PINS COULD BE  
HARMFUL TO YOUR HEALTH.**

### 1.2.3 Synchronization

There are two possible methods of wired synchronization:

1. Connect a pulse waveform to all RDEN- input pins of the Micro-readers to be synchronized. The pulse would normally be at VSL, dropping to GND for 100  $\mu$ s every 200 ms.
2. Connect all SYNC outputs to an 'Or' and then connect this as an input to RDEN- of each Micro-reader to be synchronized.

Wireless synchronization of the Micro-reader is very effective at synchronizing to adjacent readers, however problems may occur if the antennas are positioned such that a transponder can be within range of two readers at the same time. In this situation one reader could synchronize with the transponder instead of the other reader.

When the WLSC input is active the Micro-reader is in wireless synchronization mode. Wireless synchronization can also be switched on/off by a corresponding command via the serial interface. During execution of this command it has priority over the WLSC input. After the command execution the status of the WLSC input will be considered again.

---

**Note:** It is not recommended to have both wired and wireless synchronization switched on as synchronization could be unreliable.

We recommend the use of bus drivers for wired synchronization with other Micro-readers and to prevent ESD damage.

Wired or wireless synchronization prolongs the cycle time by typically 20 ms.

---

### 1.2.4 Trigger Mode

When the Micro-reader is in idle mode it is possible to trigger a single charge-only read with a power burst duration of 50 ms by taking the RDEN- pin to logic high for 100  $\mu$ s. The single read will start on the falling edge of the 100  $\mu$ s pulse.

If a transponder command is sent to the Micro-reader via the SCI while RDEN- is in a logic high state (waiting position), a falling edge would trigger execution of the command. In waiting position the Micro-reader can only store one command. This means that if two commands were to be sent to the Micro-reader while it is in the waiting position the second command will overwrite the first one.

### 1.2.5 Continuous Mode

When the CRDM input is active the Micro-reader goes into continuous charge-only read mode using a power burst duration of 50 ms. The serial data input takes priority over the CRDM input such that if a serial command is received it will be executed regardless of the state of the CRDM input. After the execution of the serial data command the Micro-reader continues with the previous read mode.

In the default continuous read mode, only those valid RO, R/W or MPT IDs that differ from the previously read ID; or valid IDs read after a "NO READ", are transferred via the SCI (Normal Mode). The Micro-reader can be set to transfer all valid IDs that are read (Line Mode) by means of a corresponding serial data command.

Without synchronization the Micro-reader has a reading frequency of approximately 10 readouts per second using a power burst duration of 50 ms. Timing is given in more detail in [Section 3.2](#).

### 1.2.6 Serial Communication

The two serial I/O pins are configured for 9600 Baud, 1 start bit, 8 data bits, no parity and 1 stop bit; they can be connected directly to a communications driver to allow a half duplex communication with a PC via its serial communications interface (for example: RS232 or RS422).

The communications protocol is specified in [Chapter 2](#).

#### Handshake

The Micro-reader accepts handshake commands  $X_{on}/X_{off}$ . When it receives an  $X_{off}$  ( $13_{hex}$ ) the Micro-reader stops its current operation and stops transmitting data via the serial port. It stays in idle mode until  $X_{on}$  ( $11_{hex}$ ) is received when it continues with the previous mode/command. During this idle period the Micro-reader accepts commands via the serial port, however, it waits for its execution until  $X_{on}$  is received. In this idle period the Micro-reader can store only one command.

---

**Note:** While receiving a command protocol from the serial port  $X_{on}/X_{off}$  is interpreted as normal data without affecting the serial communication.

---

### 1.3 Connector Pins

The Micro-reader module has 30 pin connections which are shown in [Figure 1-2](#) and listed in [Table 1-1](#).

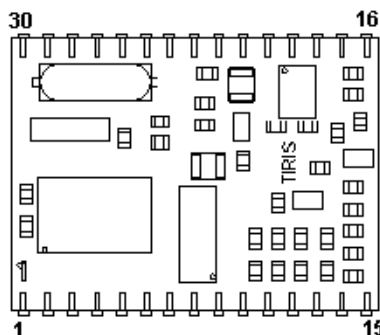

**Figure 1-2. Micro-reader Pin Connections**

**Table 1-1. Pin Connections**

Pin	Signal Name	Function
1	SYNC	Output for wired synchronization
2	RDEN-	Input for wired synchronization and single read trigger
3	–	Reserved, do not connect
4	RESET-	Reset of the Micro-reader
5	RXD	Receive Data signal input of serial interface
6	TXD	Transmit Data signal output of serial interface
7	–	Reserved, do not connect
8	–	Reserved, do not connect
9	–	Reserved, do not connect
10	–	Reserved, do not connect
11	–	Reserved, do not connect
12	–	Reserved, do not connect
13	–	Reserved, do not connect
14	–	Reserved, do not connect
15	GND	Ground for logic
16	ANT1	Antenna terminal 1
17	ANTCAP	Antenna capacitor terminal
18	–	Reserved, do not connect
19	ANT2	Antenna terminal 2
20	–	Reserved, do not connect
21	GNDP	Ground for output stage
22	VSP	Supply voltage output stage
23	–	Reserved, do not connect
24	VSL	Supply voltage logic
25	GND	Ground for logic
26	CRD	Input for continuous read mode
27	WLS	Input to switch wireless synchronization on
28	–	Reserved, do not connect
29	OKT	Output to show if a valid ID was read
30	STAT	Output to show status of RF-transmitter control signal

### 1.3.1 Pin Connection Description

- SYNC (1) Output for wired synchronization. This output is at GND level until the Micro-reader starts its read cycle, at which time it goes to VSL until the complete reading, programming or locking cycle is finished.
- RDEN- (2) Input for wired synchronization. Taking this pin to VSL acts as a hold-off for the Micro-reader's output stage preventing it from transmitting until the input returns to GND. The Micro-reader only samples this input at the start of its own reading, programming or locking cycle, this means that if the input goes to VSL after a cycle is started, the cycle is not interrupted. RDEN- is a high impedance input and must be tied to GND via a suitable resistor (27 k $\Omega$ ) when it is not being used.
- When the Micro-reader is idle it is possible to trigger a single read by taking the RDEN-pin logic high for 100 ms. The single read will start on the falling edge of the 100 ms pulse.
- RESET- (4) Taking this pin to GND holds the Micro-reader in reset. If the reset pin is not used it can be left disconnected as it is internally pulled up. Minimum pulse duration to perform a reset is 1 ms. After a reset the processor takes between 28 ms and 132 ms (typically 72 ms) before it can receive new instructions via the serial communications interface.
- RXD (5) Input configured to receive serial data commands at 9600 Baud, 1 start bit, 8 data bits, no parity and 1 stop bit.
- TXD (6) Output configured to transmit serial data at 9600 Baud, 1 start bit, 8 data bits, no parity and 1 stop bit.
- GND (15, 25) Pins 15 and 25 are ground for the logic part.
- ANT1 (16) Antenna pin for the connection of 47  $\mu$ H, low Q antennas.
- ANTCAP (17) It is possible to use antennas of lower inductance by connecting a suitable capacitor between ANT1 and ANTCAP. This additional capacitor (ceramic, 100 VDC) will be in parallel with the 30 nF resonance capacitor on board the Micro-reader (see [Figure 1-4](#) and [Appendix C](#)).
- ANT2 (19) Antenna pin (GND) for the connection of 47  $\mu$ H, low Q antennas.
- GNDP (21) Pin 21 is ground for the output stage.
- VSP (22) Pin 22 is for connecting the positive supply voltage (5 V) for the output stage.
- VSL (24) Pin 24 is for connecting the positive supply voltage (5 V) for the logic part.
- CRDM (26) Supplying pin 26 with a logic high signal causes the Micro-reader to run in a continuous charge-only read mode (see [Section 1.2.5](#) for more information).
- When the CRDM pin is tied to logic low, the Micro-reader is in an idle state waiting for commands via the serial interface or for a trigger signal (RDEN-) to start a single read out cycle. CRDM is a high impedance input and must be tied to either VSL or GND via a suitable resistor (27 k $\Omega$ ).
- WLSC (27) Pin 27 enables or disables wireless synchronization. To enable the wireless synchronization, pin 27 must be taken to VSL. When wireless synchronization is enabled, the Micro-reader will try to synchronize its transmit signals with any other readers in range. To disable wireless synchronization pin 27 must be taken to GND. Pin 27 is a high impedance input and must be tied to either VSL or GND via a suitable resistor (27 k $\Omega$ ).
- Wireless synchronization can also be switched on/off by a corresponding command via the serial interface. During execution of this command it has priority over the WLSC input.

- OKT (29) This output is set to logic high for approx. 60 ms if a valid transponder was read. It can be connected to an LED externally to indicate the result of the read cycle.
- STAT(30) Pin 30 is set to logic low when the RF-transmitter is activated. Supplying an external LED with this signal makes the status of the Micro-reader visible.

### 1.3.2 Module and Antenna Block Diagrams

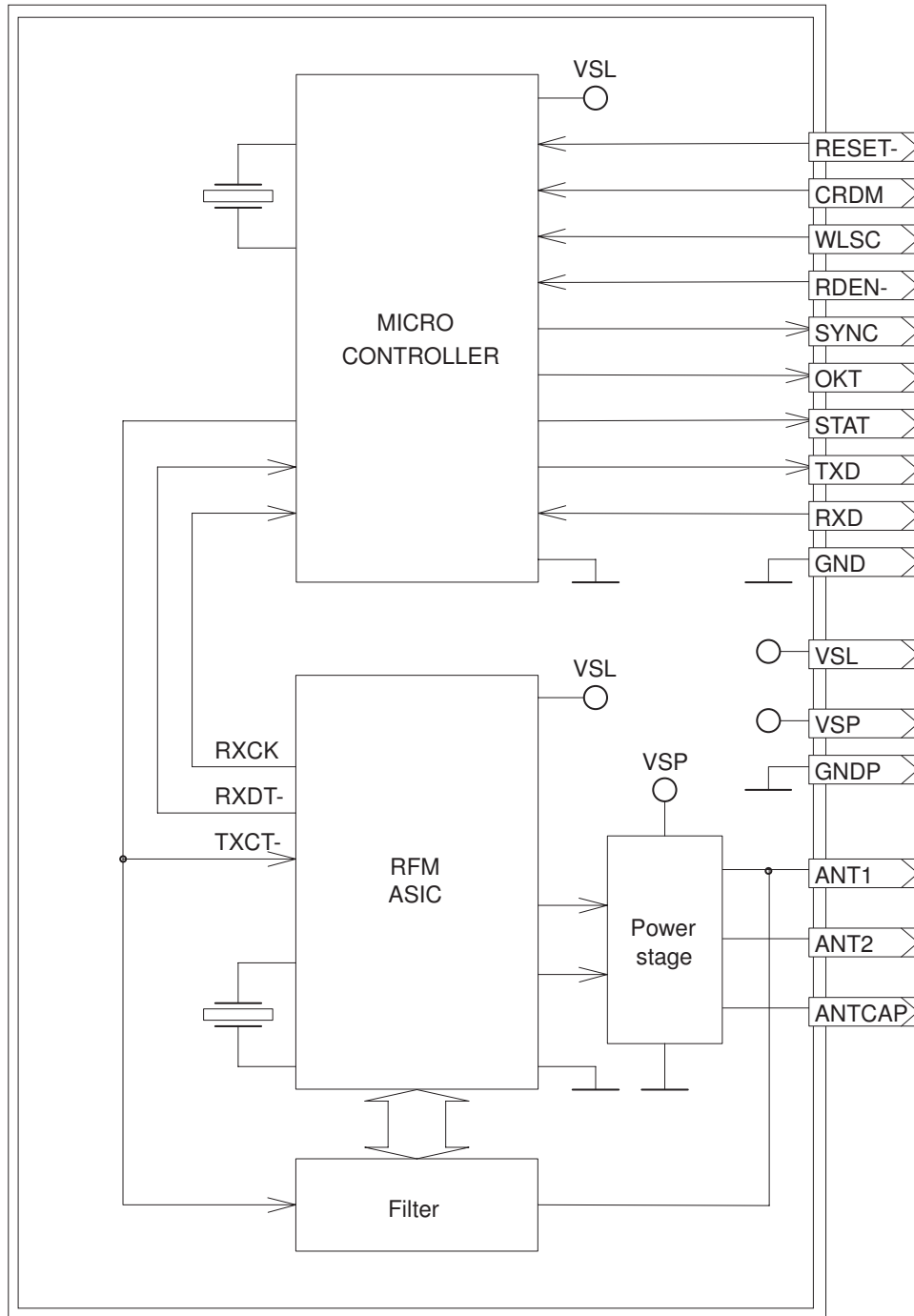

Figure 1-3. Block Diagram of the Micro-reader

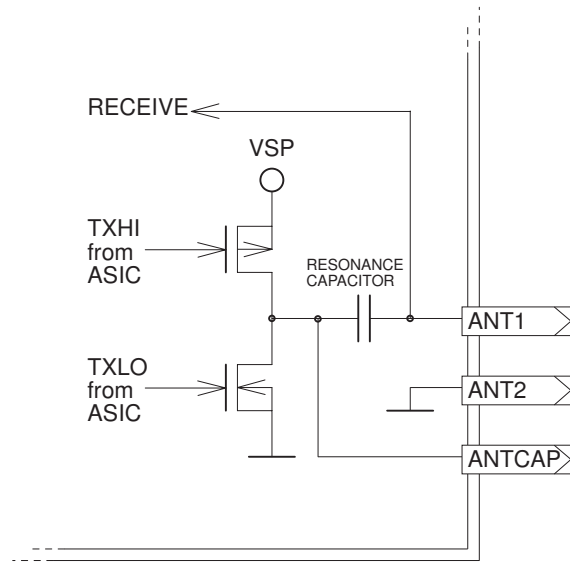

Figure 1-4. Antenna Circuit Block Diagram

## Communications Protocol

---

---

---

This chapter describes the protocol that you need to use to send instructions from your PC to the Micro-reader. It also describes the protocol that the Micro-reader uses to respond to the PC.

Topic	Page
2.1 Protocol PC to Micro-reader .....	18
2.2 Protocol Micro-reader to PC .....	20

## 2.1 Protocol PC to Micro-reader



Byte	Contents (hexadecimal value)
0	Start Mark (SOH, 01 <sub>hex</sub> )
1	Length
2	Command Field (1)
3	Command Field (2) (optional)
4(3)	Data Field (1)
.	.
.	.
N+3(2)	Data Field (N)
N+4(3)	BCC

---

**Note:** The total number of bytes sent within a protocol frame (including Start Mark and BCC) is limited to 41 bytes.

---

Examples are given in [Section 5.1](#).

### 2.1.1 Start Mark

The 'Start-Mark' signifies the beginning of a message. It is represented by the ASCII character SOH (Start Of Header, 01<sub>hex</sub>).

### 2.1.2 Length

The 'Length' byte indicates the length, in bytes, of the following Command and Data Fields.

### 2.1.3 Command Field

The 'Command Field(s)' defines the mode in which the Micro-reader operates and determines the operation that is to be carried out in the transponder. Depending on the setting of the relevant bits, the corresponding information specified in the Data Fields will be sent to the transponder or not. Thus all functions of each particular transponder type can be executed (see 2.1.4 for further information).

#### Command Field (1)

Bit	Use	Setting	Comment
0/1	Mode/Cmd	00 (MSB,LSB)	Perform single command (for example: single read, program, lock)
		01	Read in continuous Normal Mode
		10	Read in continuous Line Mode
		11	Send Micro-reader S/W version
2	FBCC Calculation	1/0	If set, Micro-reader calculates FBCC of the MPT protocol
3	Power Burst I	1/0	If set, needs to be determined in Data Field (see <a href="#">Section 2.1.4</a> )
4	Power Pause Duration	1/0	If set, needs to be determined in Data Field
5	Power Burst II	1/0	If set, needs to be determined in Data Field
6	Data	1/0	If set, needs to be determined in Data Field
7	Cmd Expansion Field	1/0	If set, Command Field (2) follows

If bit 5 (Power Burst II, for example: for programming and locking) is set, the Microreader automatically operates in single mode. Thus the user is enabled to validate the programming or lock response before a further cycle is started.

If bit 2 (FBCC calculation) and bit 6 (Data) are set, the Micro-reader automatically calculates a two byte BCC over the data to be sent to the transponder and adds it to the protocol. When bits 2 and 6 are set the PC must not send the 2 byte FBCC to the Micro-reader.

Bit 4 (Power Pause Duration) is for future use and must not be set when addressing standard TIRIS transponders.

**Example:**  $E8_{Hex} = 1110\ 1000_{BIN}$

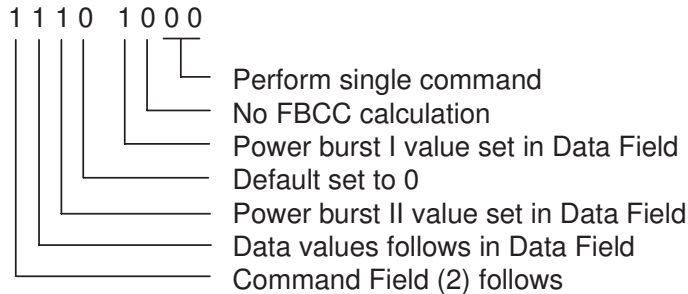

### Command Field (2)

Bit	Use	Setting	Comment
0	Special Write Timing	1/0	If set, needs to be determined in Data Field (see <a href="#">Section 2.1.4</a> )
1	Wireless Synchronization	1/0	If set, wireless synchronization is used
2	DBCC calculation	1/0	If set, Micro-reader calculates DBCC of the R/W and MPT write data
3-7	Reserved		

**Example:**  $06_{Hex} = 0000\ 0110_{BIN}$

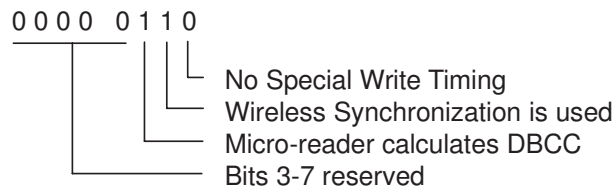

If Command Field (2) is not present, standard TIRIS write timings are used and wireless synchronization is switched on/off according to the status of input line WLSC.

---

**Note:** The settings specified in Command Field (1) and (2) are only valid during the execution of the current command.

---

### 2.1.4 Data Field

The presence of the relevant data field depends on the setting of the bits in the Command Field.

If the relevant bit (for example: Command bit 3 “Power Burst I”) is set to “1”, then Data Field 1 is present defining the Power Burst length. If the relevant bit in the Command Field is set to “0” the consequent Data Field is omitted, this results in the following data field being moved forward (decremented) by one.

Data Field	Use	Range (dec)	Comment
1	Power Burst I	1..255 ms	If bit 3 of Command Field(1) is set
2	Power Pause Duration	1..255 ms	If bit 4 of Command Field(1) is set
3	Power Burst II	1..255 ms	If bit 5 of Command Field(1) is set
4/5	toffLow (LSByte/MSByte)	28..2044 ms	If bit 0 of Command Field(2) is set
6/7	tonLow (LSByte/MSByte)	28..2044 ms	If bit 0 of Command Field(2) is set
8/9	toffHigh (LSByte/MSByte)	28..2044 ms	If bit 0 of Command Field(2) is set
10/11	tonHigh (LSByte/MSByte)	28..2044 ms	If bit 0 of Command Field(2) is set
12	# of Data Fields that follow	See <sup>(1)</sup>	If bit 6 of Command Field(1) is set
13..	Data Fields	LSByte first	

<sup>(1)</sup> The number of Data Fields must not cause an infringement of the total number of bytes allowed within a protocol frame.

Transponder command protocols are described in detail in [Section 4.1](#).

### 2.1.5 BCC

The 'BCC' field is a one-byte value of the Longitudinal Redundancy Check calculation (Xor'ed bytes) for the preceding message. The calculation is performed on the whole message excluding the Start-Mark.

**Example:** 02 08 32

```

02  0000 0010
08  0000 1000
-----
XOR 0000 1010
32  0011 0010
-----
XOR 0011 1000 = 38 (hex)

```

## 2.2 Protocol Micro-reader to PC

Start	Length	Status	Data	---	BCC
-------	--------	--------	------	-----	-----

Byte	Contents (hexadecimal value)
0	Start Mark (SOH, 01 <sub>hex</sub> )
1	Length
2	Status
3	Data Field (1) (LSByte)
.	
.	
.	
N+2	Data Field (N) (MSByte)
N+3	BCC

See [Section 5.2](#) for examples.

### 2.2.1 Start Mark

The 'Start-Mark' signifies the beginning of a message. It is represented by the ASCII character SOH (Start Of Header: 01<sub>hex</sub>)

### 2.2.2 Length

The 'Length' byte indicates the length, in bytes, of the following Status and Data Fields.

### 2.2.3 Status

The 'Status' byte provides feedback from the preceding read or program operation.

Status Bits	Setting	Comment
0,1	00 (MSB,LSB)	Transponder type: RO
	01	Transponder type: R/W
	10	Transponder type: MPT/SAMPT
	11	Other
2	1/0	If set, Startbyte detected
3	1/0	If set, DBCC O.K.
4	1/0	If set, FBCC O.K.
5	1/0	If set, Micro-reader S/W version follows
6-7	Reserved	

### 2.2.4 Data Field

Response Type	# of Bytes in Data Field	Comment
RO	8	Identification Data (LSByte first), see <a href="#">Section 4.2.1</a>
R/W	8	Identification Data (LSByte first), see <a href="#">Section 4.2.2</a>
MPT/SAMP	9	Identification Data (LSByte first), plus Read Address, see <a href="#">Section 4.2.3</a>
Other	14	Complete transponder protocol without pre-bits provided that a valid RO or R/W start byte was detected
No read	0	No Data Fields, not even transponder start byte was detected, status 03 <sub>hex</sub>
S/W version	1	For example: 15 <sub>hex</sub> means S/W version 1.5

[Section 4.2](#) provides an overview of the response telegrams of the current TIRIS transponder types.

### 2.2.5 BCC

The 'BCC' field is a one-byte value of the Longitudinal Redundancy Check calculation (Xor'ed bytes) for the preceding message. The calculation is performed on the whole message excluding the Start-Mark. An example is shown in [Section 2.1.5](#).



# Specifications

---

---

---

This chapter provides the specifications for the Micro-reader, its inputs and outputs, and its timing.

Topic	Page
3.1 Recommended Operating Conditions .....	24
3.2 Timings.....	24
3.3 Mechanical Data.....	25

### 3.1 Recommended Operating Conditions

Operating free-air temperature range	T_oper	-25 to +70°C
Storage temperature range	T_store	-40 to +85°C

**Note:** Free-air temperature: air temperature immediately surrounding the Module. If the module is incorporated into a housing, it must be guaranteed by proper design or cooling that the internal temperature does not exceed the absolute maximum ratings.

Symbol	Parameter	Min	Typ	Max	Unit
V_VSP	Supply voltage for power stage	4.5	5.0	5.5	V
V_VSL	Supply voltage for logic	4.5	5.0	5.5	V
I_VSP	Supply current for power stage		10 <sup>(1)</sup>		mA
I_VSL	Supply current for logic		30 <sup>(2)</sup>		mA
I_su	Output current sunk by an output pin		5.0	15.0	mA
I_so	Output current sourced by an output pin		5.0	15.0	mA
I_sutot	Output current sunk by all output pins		20.0	60.0	mA
I_sotot	Output current sourced by all output pins		20.0	60.0	mA
V_ret	VSP start voltage to ensure power on reset			GND	V
Vrise_ret	VSP rise rate to ensure power on reset	0.1			V/ms
I_idle	Supply current with Micro-reader idle		5.0		mA
I_act	Supply current with Micro-reader active		100 <sup>(3)</sup>		mA
ViH	Input high voltage	0.8VSL		VSL	V
ViL	Input low voltage	GND		0.2VSL	V
VoH	Output high voltage	VSL - 0.7		VSL	V
VoL	Output low voltage	GND		0.6	V
Q_Ant	Antenna quality factor	10	15	20	
L_Ant	Antenna inductance value	46.1	47.0	47.9	μH

- (1) Typical supply current (peak value) for the power stage when the RF transmitter is switched on (L = 47 μH, Q = 12).
- (2) Typical supply current for logic when the RF transmitter is switched on.
- (3) Typical supply current (average value) of the Micro-reader when the RF transmitter is switched on (L = 47 μH, Q = 12).

### 3.2 Timings

Parameter	Typ	Max	Unit
Read Cycle time without synch (no read)	100	105	ms
Read Cycle time with synch (no read)	120	175	ms
Read Cycle time without synch (valid read)	170	175	ms
Read Cycle time with synch (valid read)	190	245	ms
Interbyte time-out for serial communication	10 <sup>(1)</sup>		ms

- (1) If an Interbyte time-out occurs the Micro-reader performs a reset.

### 3.3 Mechanical Data

Parameter	Min	Typ	Max	Unit
Length	37.9	38.3	38.7	mm
Width	28.8	29.3	29.6	mm
Height including pins	12.5	13.5	14.0	mm
Weight		5.0		g

Recommended finished pin hole size is 1 mm diameter.

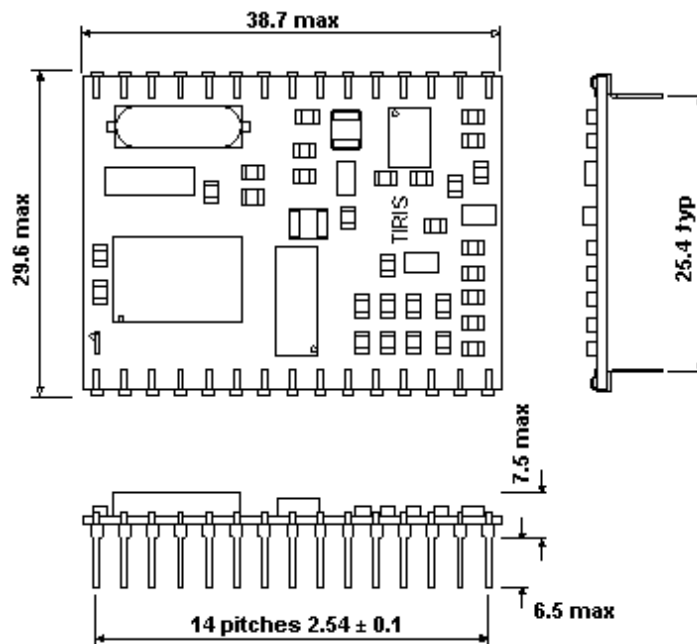

Figure 3-1. Top, Front, and Side Views (Measurements in mm)



## ***Transponder Protocols***

---

---

---

This chapter describes the protocols used when sending commands to the transponder and the protocols used by the transponder when responding.

Topic	Page
4.1 Transponder Commands.....	28
4.2 Transponder Responses.....	30

## 4.1 Transponder Commands

This section describes the protocols that need to be sent by the PC to the transponder via the Micro-reader in order to execute the required function.

### 4.1.1 Read RO, R/W

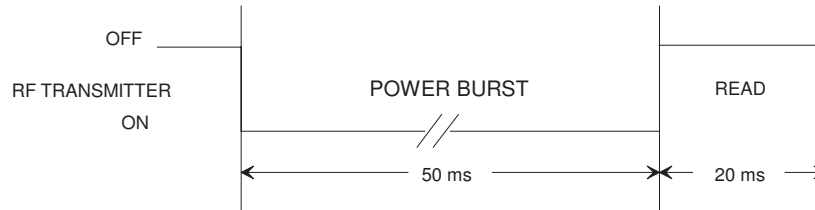

Figure 4-1. Read Function

### 4.1.2 Program R/W

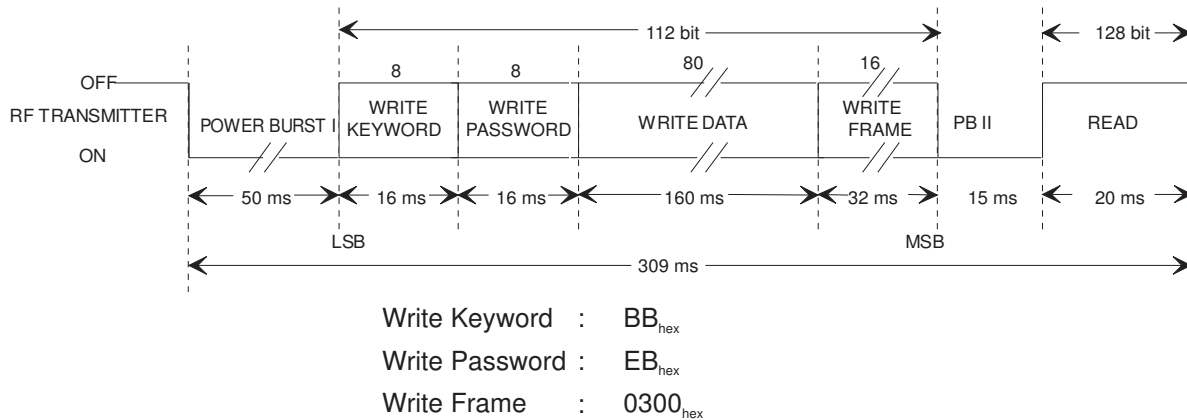

Figure 4-2. Programming Data Format of the 64-bit Read/Write Transponder

### 4.1.3 Addressing MPTs/SAMPTs

Since MPT/SAMPTs allow the execution of the different commands applicable to multiple pages the 'Write Address' needs to be sent within the protocol in order to determine the function to be executed with a specific MPT/SAMPT page.

		WRITE ADDRESS						
		MSB		LSB				
		P	P	P	P	C	C	
		PAGE		COMMAND				
		MSB	LSB	MSB	LSB			
Page 1		0	0	0	0	0	0	General read page
Page 2		0	0	0	0	1	0	Program page
...		.	.	.	.	1	0	Lock page
Page 16		0	1	0	0	0	0	Selective read
Page 17		0	1	0	0	0	1	

### 4.1.3.1 General Read Page of MPT/SAMPT

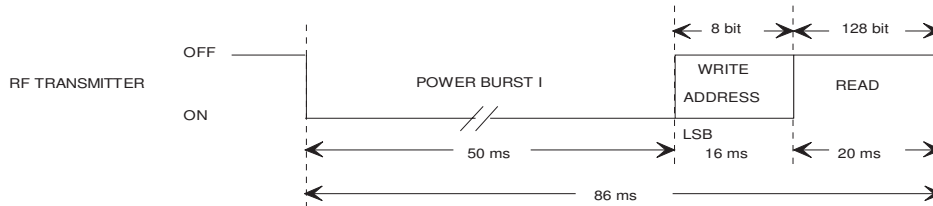

Figure 4-3. Data Format of the General Read Page Function

### 4.1.3.2 Program Page of MPT/SAMPT

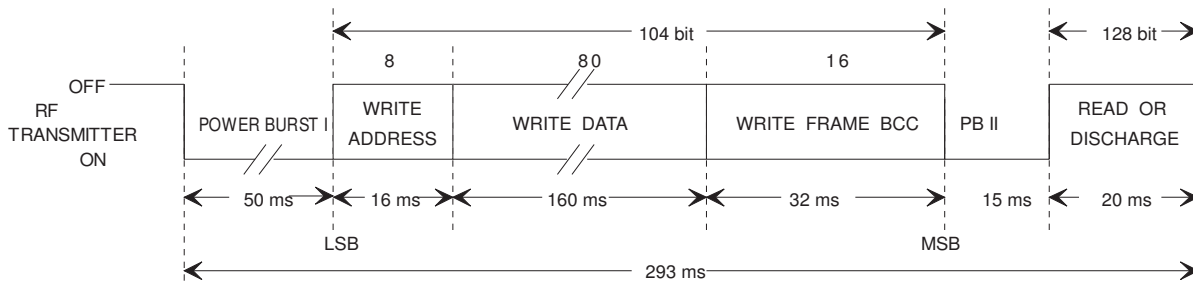

Figure 4-4. Programming Data Format of the MPT

### 4.1.3.3 Lock Page of MPT/SAMPT

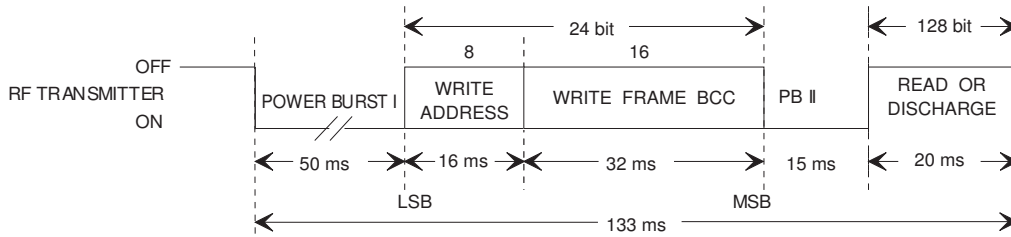

Figure 4-5. Lock Page of MPT/SAMPT

### 4.1.3.4 Selective Read Page of SAMPT

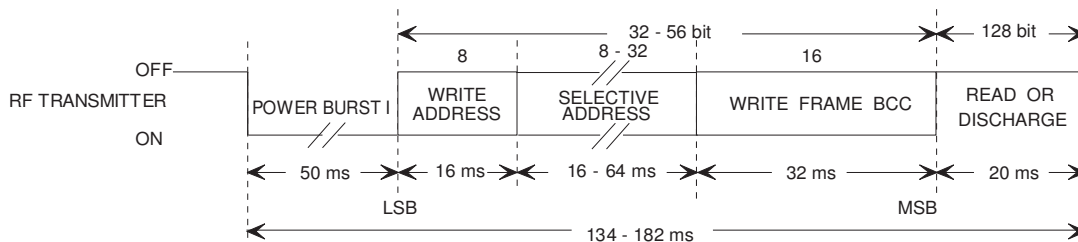
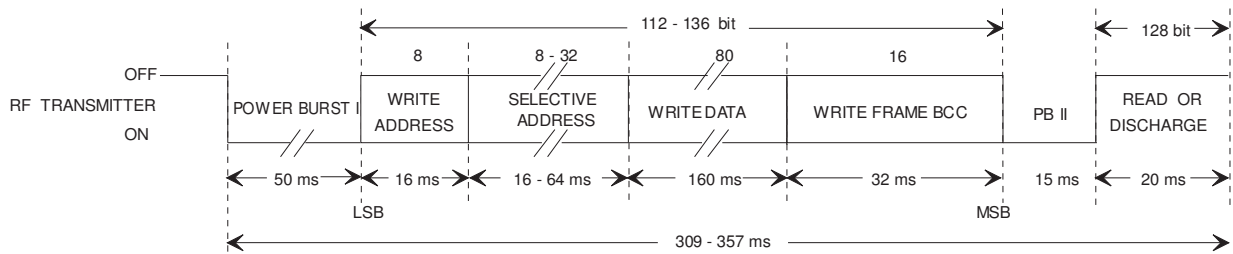

Figure 4-6. Data Format of the Selective Read Page Function

Transponder Responses

**4.1.3.5 Selective Program Page of SAMPT**



**Figure 4-7. Data Format of the Selective Program Page Function**

**4.1.3.6 Selective Lock Page of SAMPT**

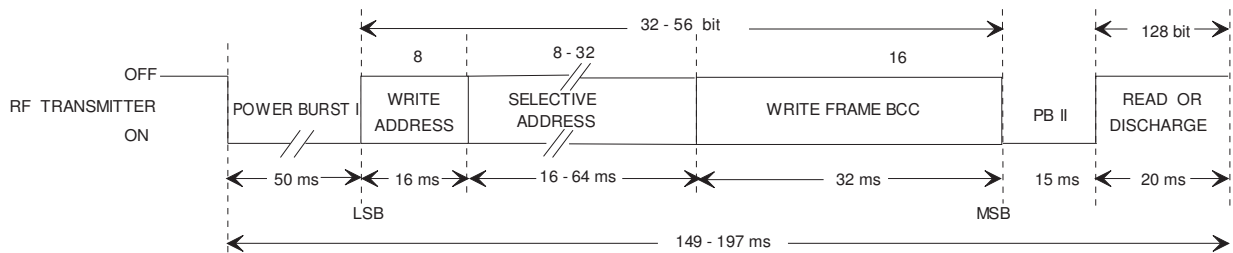
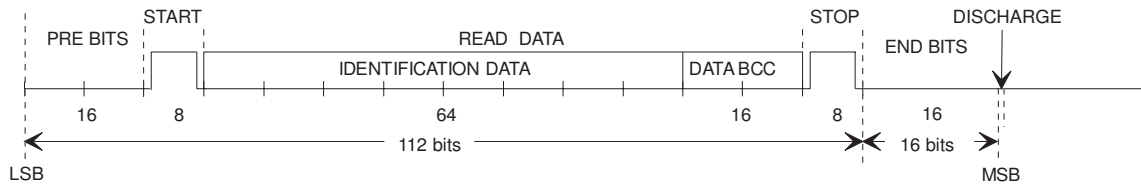

**Figure 4-8. Data Format of the Selective Lock Page Function**

**4.2 Transponder Responses**

This section shows the response telegrams of the current TIRIS transponder types.

**4.2.1 Read Only Transponder**



**Figure 4-9. RO Read Data Format**

**4.2.2 Read/Write Transponder**

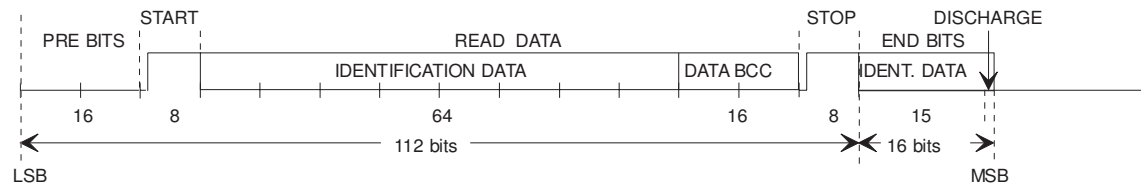

**Figure 4-10. R/W Read Data Format**

### 4.2.3 MPT/SAMPT

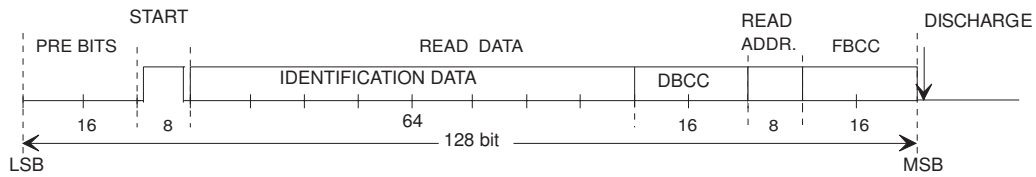

**Figure 4-11. MPT/SAMPT Read Data Format**

The Read Address consists of a 2-bit status field and a 6-bit page field. The status field provides information about the function the multipage transponder has executed and the page field shows which page was affected.

READ ADDRESS				
	MSB		LSB	
	P	P	P	
	P	P	P	
	C	C		
	PAGE		COMMAND	
	MSB	LSB	MSB LSB	
Page 1	0	0	00	Read unlocked page
Page 2	0	0	01	Programming done
. . .	.	.	10	Read locked page
Page 16	0	1	11	Reserved (see Note A)
Page 17	0	1	00	Read unlocked page, locking not correctly executed
	0	0	01	Programming done, but possibly not reliable
	0	0	10	Read locked page, but locking possibly not reliable

A If the status indicates 'Reserved', the read data cannot be interpreted as identification data.

---

**Note:** It is strongly recommended to verify whether the requested function has actually been carried out in the transponder by checking the Read Address. If a 'not reliable' response message is received, the command must be sent again to guarantee transponder data retention.

---



## Communication Protocol Examples

---

---

---

This chapter provides some examples of some actual commands sent to a transponder and some possible responses.

Topic	Page
5.1 PC to Micro-reader .....	34
5.2 Micro-reader to PC .....	38

## 5.1 PC to Micro-reader

### 5.1.1 Read RO, R/W

Byte	Content (hex)	Comment	Description
0	01	Start Mark	
1	02	Length	Two bytes follow excluding BCC
2	08	Command Field (1)	Perform Single command, send Power Burst I
3	32	Data Field (1)	Power Burst I with 50 ms duration (charge-up)
4	38	BCC	BCC over previous bytes excluding Start Mark

### 5.1.2 Program R/W Transponder

The following sequence of bytes programs a R/W transponder with:

00 00 00 00 00 00 00 01  
 MSByte LSByte

Byte	Content (hex)	Comment	Description
0	01	Start Mark	
1	11	Length	17 bytes follow excluding BCC
2	E8	Command Field (1)	Perform Single command, no FBCC calculation, send Power Burst I and II with Data Command Field (2) follows
3	06	Command Field (2)	Wireless synchronization, calculate DBCC of the R/W and MPT write data
4	32	Data Field (1)	Power Burst I with 50 ms duration (charge-up)
5	0F	Data Field (2)	Power Burst II with 15 ms duration (Progr. burst)
6	0C	Data Field (3)	12 Data Fields follow
7	BB	Data Field (4)	Write Keyword
8	EB	Data Field (5)	Write Password
9	01	Data Field (6)	Programming data (LSByte)
10	00	Data Field (7)	Programming data
11	00	Data Field (8)	Programming data
12	00	Data Field (9)	Programming data
13	00	Data Field (10)	Programming data
14	00	Data Field (11)	Programming data
15	00	Data Field (12)	Programming data
16	00	Data Field (13)	Programming data (MSByte)
17	00	Data Field (14)	Write Frame
18	03	Data Field (15)	Write Frame
19	9C	BCC	BCC over previous bytes excluding Start Mark

### 5.1.3 General Read Page of MPT

The following sequence of bytes reads page 2 of an MPT.

Byte	Content (hex)	Comment	Description
0	01	Start Mark	
1	04	Length	Four bytes follow excluding BCC
2	48	Command Field (1)	Perform Single command, send Power Burst I with data
3	32	Data Field (1)	Power Burst I with 50 ms duration (charge-up)
4	01	Data Field (2)	One Data Field follows
5	08	Data Field (3)	Write Address specifying General Read Page 2
6	77	BCC	BCC over previous bytes excluding Start Mark

### 5.1.4 Program Page of MPT

The following sequence of bytes programs page 2 of an MPT with:

00 00 00 00 00 2D C6 47  
 MSByte LSByte

Byte	Content (hex)	Comment	Description
0	01	Start Mark	
1	0F	Length	15 bytes follow excluding BCC
2	6C	Command Field (1)	Perform Single command, calculate FBCC, send Power Burst I & II with Data
3	32	Data Field (1)	Power Burst I with 50 ms duration (charge-up)
4	0F	Data Field (2)	Power Burst II with 15 ms duration (Progr. burst)
5	0B	Data Field (3)	11 Data Fields follow
6	09	Data Field (4)	Write Address specifying Program Page 2
7	47	Data Field (5)	Programming data (LSByte)
8	C6	Data Field (6)	Programming data
9	2D	Data Field (7)	Programming data
10	00	Data Field (8)	Programming data
11	00	Data Field (9)	Programming data
12	00	Data Field (10)	Programming data
13	00	Data Field (11)	Programming data
14	00	Data Field (12)	Programming data (MSByte)
15	96	Data Field (13)	DBCC (LSByte)
16	50	Data Field (14)	DBCC (MSByte)
17	36	BCC	BCC over previous bytes excluding Start Mark

### 5.1.5 Lock Page of MPT

The following sequence of bytes locks page 2 of an MPT.

Byte	Content (hex)	Comment	Description
0	01	Start Mark	
1	05	Length	Five bytes follow excluding BCC
2	6C	Command Field (1)	Perform Single command, calculate FBCC, send Power Burst I & II with data
3	32	Data Field (1)	Power Burst I with 50 ms duration (charge-up)
4	07	Data Field (2)	Power Burst II with 15 ms duration (Progr. burst)
5	01	Data Field (3)	One Data Field follows
6	0A	Data Field (4)	Write Address specifying Lock Page 2
7	5F	BCC	BCC over previous bytes excluding Start Mark

### 5.1.6 Selective Read Page of SAMPT

The following sequence of bytes reads page 2 of an SAMPT.

The 24 bit selective address =

12 34 56

MSByte LSByte

Byte	Content (hex)	Comment	Description
0	01	Start Mark	
1	07	Length	7 bytes follow excluding BCC
2	4C	Command Field (1)	Perform Single command, calculate FBCC, send Power Burst I with Data
3	32	Data Field (1)	Power Burst I with 50 ms duration (charge-up)
4	04	Data Field (2)	4 Data Fields follow
5	0B	Data Field (3)	Write Address specifying selective Read Page 2
6	56	Data Field (4)	Selective Address LSB
7	34	Data Field (5)	Selective Address
8	12	Data Field (6)	Selective Address MSB
9	06	BCC	BCC over previous bytes excluding Start Mark

### 5.1.7 Selective Program Page of SAMPT

The following sequence of bytes selective programs page 2 of an SAMPT with:

00 00 00 00 00 00 00 11  
 MSByte LSByte

The 24 bit selective address =

12 34 56  
 MSByte LSByte

Byte	Content (hex)	Comment	Description
0	01	Start Mark	
1	12	Length	18 bytes follow excluding BCC
2	6C	Command Field (1)	Perform Single command, calculate FBCC, send Power Burst I & II with Data
3	32	Data Field (1)	Power Burst I with 50 ms duration (charge-up)
4	0F	Data Field (2)	Power Burst II with 15 ms duration (Progr. burst)
5	0E	Data Field (3)	14 Data Fields follow
6	09	Data Field (4)	Write Address specifying Program Page 2
7	56	Data Field (5)	Selective Address LSB
8	34	Data Field (6)	Selective Address
9	12	Data Field (7)	Selective Address MSB
10	11	Data Field (8)	Programming data (LSByte)
11	00	Data Field (9)	Programming data
12	00	Data Field (10)	Programming data
13	00	Data Field (11)	Programming data
14	00	Data Field (12)	Programming data
15	00	Data Field (13)	Programming data
16	00	Data Field (14)	Programming data
17	00	Data Field (15)	Programming data (MSByte)
18	9F	Data Field (16)	DBCC (LSByte)
19	BD	Data Field (17)	DBCC (MSByte)
20	34	BCC	BCC over previous bytes excluding Start Mark

### 5.1.8 Selective Lock Page of SAMPT

The following sequence of bytes locks page 2 of an SAMPT.

The 24 bit selective address =

12    34    56  
MSByte    LSByte

Byte	Content (hex)	Comment	Description
0	01	Start Mark	
1	08	Length	8 bytes follow excluding BCC
2	6C	Command Field (1)	Perform Single command, calculate FBCC, send Power Burst I & II with Data
3	32	Data Field (1)	Power Burst I with 50 ms duration (charge-up)
4	0F	Data Field (2)	Power Burst II with 15 ms duration (Progr. burst)
5	04	Data Field (3)	4 Data Fields follow
6	0A	Data Field (4)	Write Address specifying selective Lock Page 2
7	56	Data Field (5)	Selective Address LSB
8	34	Data Field (6)	Selective Address
9	12	Data Field (7)	Selective Address MSB
10	27	BCC	BCC over previous bytes excluding Start Mark

## 5.2 Micro-reader to PC

### 5.2.1 Successful Read of RO

Byte	Content (hex)	Comment	Description
0	01	Start Mark	
1	09	Length	9 bytes follow excluding BCC
2	0C	Status	Valid RO, Startbyte detected, DBCC O.K.
3	6A	Data Field (1)	Identification Data (LSByte)
4	58	Data Field (2)	Identification Data
5	4C	Data Field (3)	Identification Data
6	00	Data Field (4)	Identification Data
7	00	Data Field (5)	Identification Data
8	00	Data Field (6)	Identification Data
9	00	Data Field (7)	Identification Data
10	00	Data Field (8)	Identification Data (MSByte)
11	7B	BCC	BCC over previous bytes excluding Start Mark

### 5.2.2 Successful Program Page 2 of MPT

Byte	Content (hex)	Comment	Description
0	01	Start Mark	
1	0A	Length	10 bytes follow excluding BCC
2	1E	Status	Valid MPT, Startbyte detected, DBCC O.K., FBCC O.K.
3	47	Data Field (1)	New Identification Data (LSByte)
4	C6	Data Field (2)	New Identification Data
5	2D	Data Field (3)	New Identification Data
6	00	Data Field (4)	New Identification Data
7	00	Data Field (5)	New Identification Data
8	00	Data Field (6)	New Identification Data
9	00	Data Field (7)	New Identification Data
10	00	Data Field (8)	New Identification Data (MSByte)
11	09	Data Field (9)	Read Address specifying successful progr. of page 2
12	B1	BCC	BCC over previous bytes excluding Start Mark

### 5.2.3 No Read

Byte	Content (hex)	Comment	Description
0	01	Start Mark	
1	01	Length	One byte follows excluding BCC
2	03	Status	Other, no Startbyte, DBCC not O.K., FBCC not O.K.
3	02	BCC	BCC over previous bytes excluding Start Mark



## ***CE Declaration***

---

---

---

The Micro-reader module complies with the European CE requirements specified in the EMC Directive 89/336/EEC. The relevant documentation numbers are:

Declaration of Conformity 11-06-02-005

Type Examination Certificate 11-06-05-001

If the Micro-reader is operated from a mains power supply, all power connections and additional components of the final device must comply with the European EMC directive.

Additional connections may have a length of up to 2 m maximum, or in fixed installations up to 1 m maximum.

European customers must themselves make sure that the final device conforms to the European EMC Directive.



## Demonstration Circuit

The Micro-reader module can be demonstrated using the circuit shown in [Figure B-1](#).

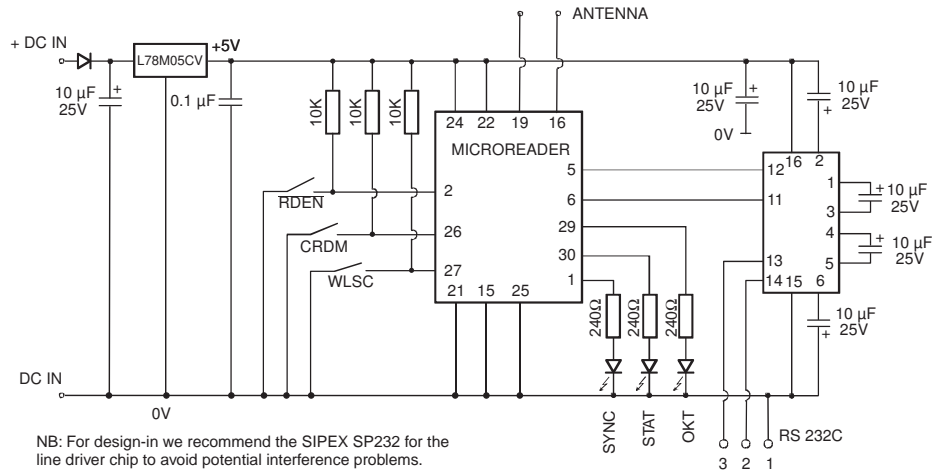

**Figure B-1. Micro-reader Demonstration Circuit**



## Antenna Design

### C.1 Introduction

This appendix gives an example of how you could construct an antenna to work with the Micro-reader. It also provides information about calculating the Q factor and adapting the inductance range.

The antenna properties should be:

- Q factor less than 20
- Inductance between 46  $\mu$ H and 48  $\mu$ H
- Recommended maximum size 200 mm  $\times$  200 mm

### C.2 Antenna Construction

Item List:

Item	Description	Quantity
1	Enamelled solid copper wire, 0.2 mm	2.1 g
2	Tape, 10 mm wide	20 mm
3	Block cloth tape, 12 mm wide	0.12 m
4	Spiroband, 3 mm diameter	0.24 m
5	Screened antenna lead	1 m

Method:

- Wind 15 turns of item 1 with a diameter of 75 mm.
- Leave about 50 mm free at the ends, cross the wires (at the  $\pm$  50 mm point) and secure them together using the tape (item 2).
- Twist the spiroband (item 4) onto the coil that you have just made, leaving the start and finish ends free.
- Strip the insulating braid back at the end of the antenna lead (item 5). Wrap the start and finish ends at least three times around the bared ends and solder the joints (the polarity is not important).
- Tightly bind the soldered joints to the spiroband using the cloth tape (item 3).

This method should result in a 47  $\mu$ H antenna with a quality factor of approximately 17 to 18.

### C.3 Q Factor

If the antenna's Q factor exceeds 20:

1. The output capacitors will be overloaded and long term damage could result.
2. The antenna may still be resonating when the response from the transponder is received. Without built-in damping the data will not be correctly received.
3. The antenna may be detuned if there is any metal in the area.

The following formula provides an approximate method of calculating the Q factor of the antenna:

$$Q = \frac{2\pi fL}{R}$$

Where: f = 134200 Hz (Frequency = 134.2 kHz)

L = Inductance (H)

R = Series resistance ( $\Omega$ )

Example:

Inductance (L) = 47  $\mu$ H

Resistance (R) = 2.2  $\Omega$

$$\begin{aligned} Q &= \frac{2 \times \pi \times 134200 \times 0.000047}{2.2} \\ &= \frac{39.636}{2.2} \\ &= 18 \end{aligned}$$

### C.4 Adapting the Inductance Range

If your antenna is outside of the required inductance range of 46 to 48  $\mu$ H, you can adapt it to work with the Micro-reader by adding an external capacitor to it, either in series or in parallel. You can use this external capacitor to change the inductance range by  $\pm 5 \mu$ H.

You can work out the total resonance capacity using the following formula:

$$C_{\text{tot}} = 1 / (4\pi^2 L_{\text{Ant}} f^2)$$

If the antenna inductance is less than 46.1  $\mu$ H you can add an extra capacitor (externally) to the antenna between pin 16 (ANT1) and pin 17 (ANTCAP). The formula to work out the value of this capacitor is:

$$C_{\text{ext}} = C_{\text{tot}} - 30 \text{ nF}$$

If the antenna inductance is more than 47.9  $\mu$ H you can add an extra capacitor in series with the antenna between pin 19 (ANT2) and the antenna. The formula to work out the value of this capacitor is:

$$\frac{1}{C_{\text{ext}}} = \frac{1}{C_{\text{tot}}} - \frac{1}{30 \text{ nF}}$$

## IMPORTANT NOTICE

Texas Instruments Incorporated and its subsidiaries (TI) reserve the right to make corrections, modifications, enhancements, improvements, and other changes to its products and services at any time and to discontinue any product or service without notice. Customers should obtain the latest relevant information before placing orders and should verify that such information is current and complete. All products are sold subject to TI's terms and conditions of sale supplied at the time of order acknowledgment.

TI warrants performance of its hardware products to the specifications applicable at the time of sale in accordance with TI's standard warranty. Testing and other quality control techniques are used to the extent TI deems necessary to support this warranty. Except where mandated by government requirements, testing of all parameters of each product is not necessarily performed.

TI assumes no liability for applications assistance or customer product design. Customers are responsible for their products and applications using TI components. To minimize the risks associated with customer products and applications, customers should provide adequate design and operating safeguards.

TI does not warrant or represent that any license, either express or implied, is granted under any TI patent right, copyright, mask work right, or other TI intellectual property right relating to any combination, machine, or process in which TI products or services are used. Information published by TI regarding third-party products or services does not constitute a license from TI to use such products or services or a warranty or endorsement thereof. Use of such information may require a license from a third party under the patents or other intellectual property of the third party, or a license from TI under the patents or other intellectual property of TI.

Reproduction of information in TI data books or data sheets is permissible only if reproduction is without alteration and is accompanied by all associated warranties, conditions, limitations, and notices. Reproduction of this information with alteration is an unfair and deceptive business practice. TI is not responsible or liable for such altered documentation.

Resale of TI products or services with statements different from or beyond the parameters stated by TI for that product or service voids all express and any implied warranties for the associated TI product or service and is an unfair and deceptive business practice. TI is not responsible or liable for any such statements.

Following are URLs where you can obtain information on other Texas Instruments products and application solutions:

<b>Products</b>		<b>Applications</b>	
Amplifiers	<a href="http://amplifier.ti.com">amplifier.ti.com</a>	Audio	<a href="http://www.ti.com/audio">www.ti.com/audio</a>
Data Converters	<a href="http://dataconverter.ti.com">dataconverter.ti.com</a>	Automotive	<a href="http://www.ti.com/automotive">www.ti.com/automotive</a>
DSP	<a href="http://dsp.ti.com">dsp.ti.com</a>	Broadband	<a href="http://www.ti.com/broadband">www.ti.com/broadband</a>
Interface	<a href="http://interface.ti.com">interface.ti.com</a>	Digital Control	<a href="http://www.ti.com/digitalcontrol">www.ti.com/digitalcontrol</a>
Logic	<a href="http://logic.ti.com">logic.ti.com</a>	Military	<a href="http://www.ti.com/military">www.ti.com/military</a>
Power Mgmt	<a href="http://power.ti.com">power.ti.com</a>	Optical Networking	<a href="http://www.ti.com/opticalnetwork">www.ti.com/opticalnetwork</a>
Microcontrollers	<a href="http://microcontroller.ti.com">microcontroller.ti.com</a>	Security	<a href="http://www.ti.com/security">www.ti.com/security</a>
Low Power Wireless	<a href="http://www.ti.com/lpw">www.ti.com/lpw</a>	Telephony	<a href="http://www.ti.com/telephony">www.ti.com/telephony</a>
		Video & Imaging	<a href="http://www.ti.com/video">www.ti.com/video</a>
		Wireless	<a href="http://www.ti.com/wireless">www.ti.com/wireless</a>

Mailing Address: Texas Instruments  
Post Office Box 655303 Dallas, Texas 75265

## Looking for pricing, stock, or lifecycle information?

Click below to explore more details on WIN SOURCE:

 [View RI-STU-MRD1-30](#) on WIN SOURCE

 [Texas Instruments](#) Information

## Optimize Your Supply Chain with WIN SOURCE Solutions

-  Global Sourcing Solution
-  Obsolete Management
-  Cost Control Management
-  Shortage Management
-  Alternative Solution
-  Excess Inventory Management