



THE DATASHEET OF RFX8425



DATA SHEET

RFX8425: 2.4 GHz CMOS WLAN/Bluetooth® Dual-Mode RFeIC with PA, LNA, and SP3T

Applications

- Smartphones, feature phones, and MIDs with WLAN/Bluetooth
- WLAN/Bluetooth platforms requiring shared antenna
- Laptop/netbook/smartbook with embedded WiFi and Bluetooth
- Portable platforms with integrated 802.11b/g/n and Bluetooth
- RoHS and REACH compliant

Features

- Combines 802.11b/g/n/ac and Bluetooth applications
- High-linearity PA for 802.11 b/g/n/ac WLAN
- Low noise figure WLAN receive LNA with bypass for near range operation
- Built-in directional coupler-based output power detector
- ESD protection circuitry on all ports
- DC decoupled RF ports and VDD/RF isolation
- Small QFN (16-lead, 2.3 x 2.3 x 0.45 mm) package (MSL1, 260 °C per JEDEC J-STD-020)



Skyworks Green™ products are compliant with all applicable legislation and are halogen-free. For additional information, refer to *Skyworks Definition of Green™*, document number SQ04-0074.

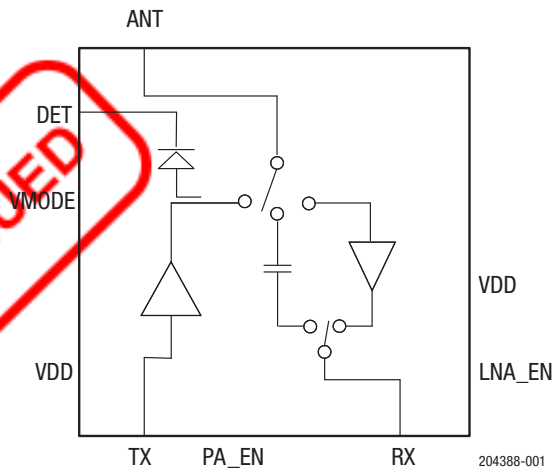
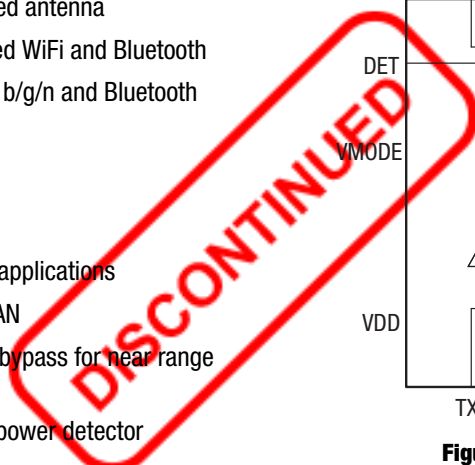

Figure 1. RFX8425 Block Diagram

Description

The RFX8425 is a pure CMOS-based, single-chip/single-die RFeIC (RF front-end integrated circuit) that incorporates all key RF functionality needed for implementing high-performance RF front-end for WLAN IEEE 802.11b/g/n and OFDM/256QAM operation in the 2.4 GHz band. The RFX8425 architecture integrates a high-efficiency high-linearity power amplifier (PA) with harmonic filter, a directional coupler-based power detector, a low-noise amplifier (LNA), an SP3T switch for Bluetooth antenna sharing, and an additional SPDT switch for selection between LNA and Bypass in receive mode. All the impedance matching components and DC-block capacitors are also integrated to minimize the PCB footprint for system implementation.

The RFX8425 is assembled in an ultra-compact, low-profile 2.3 x 2.3 x 0.45 mm 16-lead QFN package. It has simple and low-voltage CMOS control logic, and requires minimal external components. Designed to work in the 3.0 to 3.6 V range, the RFX8425 is an ideal RF front-end solution for implementing 2.4 GHz WLAN/BT in PC clients, tablets, and many other mobile platforms including smartphones that have a PMIC available to provide the required supply voltage for the RF front-end.

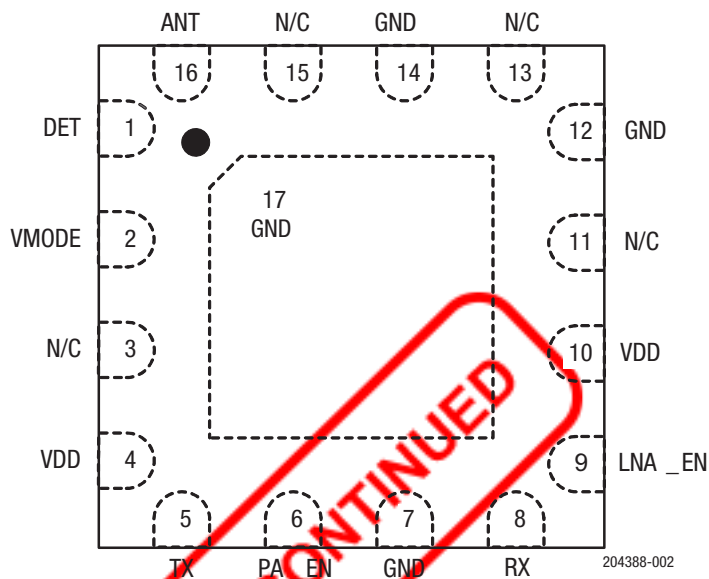

Figure 2. RFX8425 Pinout (Top View)

Table 1. RFX8425 Signal Descriptions

Pin	Name	Description	Pin	Name	Description
1	DET	PA power detector output voltage	8	RX	WLAN RX signal port to the transceiver/BT port (DC shorted to GND)
2	VMODE	CMOS logic control used for PA Mode control in rome platform (unused for rhino platform)	9	LNA_EN	CMOS logic control to enable LNA
4, 10	VDD	DC voltage supply	3, 11, 13, 15	N/C	Not connected internally (can be grounded or left open)
5	TX	WLAN TX signal port from the transceiver (DC shorted to GND)	7, 12, 14, 17	GND	Ground (must be connected to ground in the application circuit)
6	PA_EN	CMOS logic control to enable WLAN transmit	16	ANT	RF signal port to/from the antenna (DC shorted to GND)

Electrical and Mechanical Specifications

The absolute maximum ratings of the RFX8425 are provided in Table 2. The recommended operating conditions are specified in Table 3.

The electrical specifications are provided in Tables 4 and 5. The state of the RFX8425 is determined by the logic provided in Table 6.

Table 2. RFX8425 Absolute Maximum Ratings¹

Parameter	Conditions	Minimum	Maximum	Units
DC VDD voltage supply	All VDD pins	-0.3	4	V
DC control pin voltage	All control pins	-0.3	3.6	V
DC VDD current consumption	Through VDD pins when TX is ON		350	mA
TX RF input power			+10	dBm
ANT RF input power	Bypass mode		+20	dBm
Junction temperature			150	°C
Storage ambient temperature	Appropriate care required according to JEDEC Standards	-40	+150	°C
Operating ambient temperature		-20	+85	°C
Electrostatic discharge: Human Body Model (HBM)	All pins	±4250		V

¹ Exposure to maximum rating conditions for extended periods may reduce device reliability. There is no damage to device with only one parameter set at the limit and all other parameters set at or below their nominal value. Exceeding any of the limits listed here may result in permanent damage to the device. All maximum RF input power ratings assume 50 Ω terminal impedance.

ESD HANDLING: *Although this device is designed to be as robust as possible, electrostatic discharge (ESD) can damage this device. This device must be protected at all times from ESD when handling or transporting. Static charges may easily produce potentials of several kilovolts on the human body or equipment, which can discharge without detection. Industry-standard ESD handling precautions should be used at all times.*

Table 3. RFX8425 Recommended Operating Conditions

Parameter	Conditions	Min	Typ	Max	Units
VDD voltage supply ¹	All VDD pins	3.0	3.3	3.6	V
RF port impedance			50		Ω
Control voltage high ²		1.2		3.6	V
Control voltage low		0		0.4	V
Control pin current			1		µA
Shutdown current			6		µA
PA turn on/off time				0.4	µs
LNA turn on/off time				0.4	µs
θ _{jc} ³			29		°C/W
θ _{ja}			45		°C/W

¹ For normal operation of the RFX8425, VDD must be continuously applied to all VDD supply pins.

² If control voltage can exceed 2.0 V, a 1 kΩ to 10 kΩ series resistor is recommended for the application circuit on each control line.

³ Thermal measurements were performed on a test EVB under typical use conditions. Please contact Skyworks for details regarding the test conditions and the configuration of the thermal vias on the EVB. Refer to the PCB Land Pattern in Figure 3 for recommended thermal vias.

Table 4. RFX8425 Transmit Electrical Characteristics (VDD = 3.3 V, TA = +25°C, Unless Otherwise Specified)

Parameter	Test Condition	Min	Typ	Max	Units
Operating frequency band		2.4		2.5	GHz
Linear output power for 802.11ac	Dynamic EVM < -35 dB for MCS9/VHT40		+18		dBm
Linear output power for 802.11n	Dynamic EVM < -32 dB for MCS7/HT20		+18.5		dBm
Linear output power for 802.11a	Dynamic EVM < -32 dB for 64 QAM/54 Mbps		+19		dBm
Linear output power for 802.11a, 6 Mbps	For 802.11b 1 Mbps CCK mask compliance with 1.5 dB margin		+22		dBm
Total supply current for 802.11ac	For P _{OUT} = +18 dBm, MCS9/VHT40		140		dB
TX small signal gain			26		mA
Second harmonic	P _{OUT} = +22 dBm, 11b 1 Mbps CCK		-8		dB
Third harmonic	P _{OUT} = +22 dBm, 11b 1 Mbps CCK		-27		dBm/MHz
Power detector voltage	Measured with 10 kΩ load, P _{OUT} = +5 to +20 dBm		250 to 1000		mV
Input return loss			-12		dB
Output return loss			-6		dB

Table 5. RFX8425 Receive Electrical Characteristics (VDD = 3.3 V, TA = +25°C, Unless Otherwise Specified)

Parameter	Test Condition	Min	Typical	Max	Units
Operating frequency		2.4		2.5	GHz
Small-signal gain (high-gain mode)			16		dB
Noise figure			2.6		dB
LNA quiescent current			12		mA
IIP3			+3.0		dBm
Insertion loss (bypass mode)			1.5		dB

Table 6. RFX8425 Control Logic¹

Mode of Operation	TXEN	LEN	RXEN
Bypass/sleep mode	0	0	0
High linearity transmit mode	1	X	X
Receive mode with LNA ON	0	1	1
Power save transmit mode	0	0	1
Power save transmit mode	All others		

¹ "1" denotes high voltage state (> 1.2 V)

"0" denotes low voltage stage (< 0.4 V) at control pins

"X" denotes do not care

1 kΩ – 10 kΩ series resistor may be required for each control line.

Package Dimensions

The PCB layout footprint for the RFX8425 is shown in Figure 3. The typical part marking is shown in Figure 4. Package dimensions are shown in Figure 5.

Package and Handling Information

Instructions on the shipping container label regarding exposure to moisture after the container seal is broken must be followed. Otherwise, problems related to moisture absorption may occur when the part is subjected to high temperature during solder assembly.

The RFX8425 is rated to Moisture Sensitivity Level 1 (MSL1) at 260 °C. It can be used for lead or lead-free soldering. For additional information, refer to the Skyworks Application Note, *Solder Reflow Information*, document number 200164.

Care must be taken when attaching this product, whether it is done manually or in a production solder reflow environment. Production quantities of this product are shipped in a standard tape and reel format.

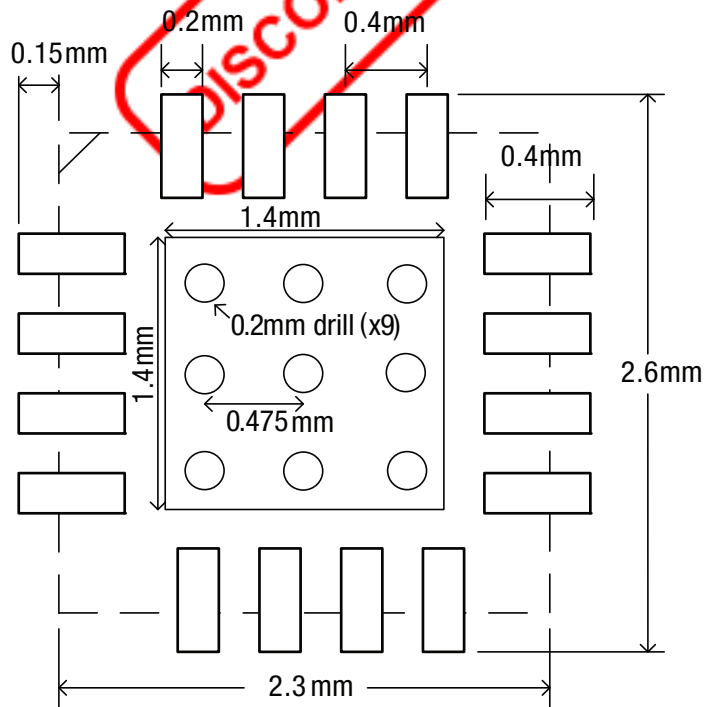

204388-003

Figure 3. RFX8425 PCB Layout Footprint

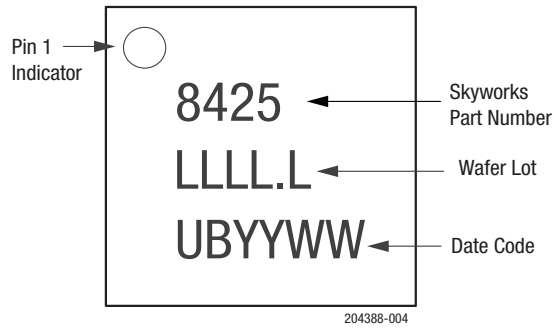
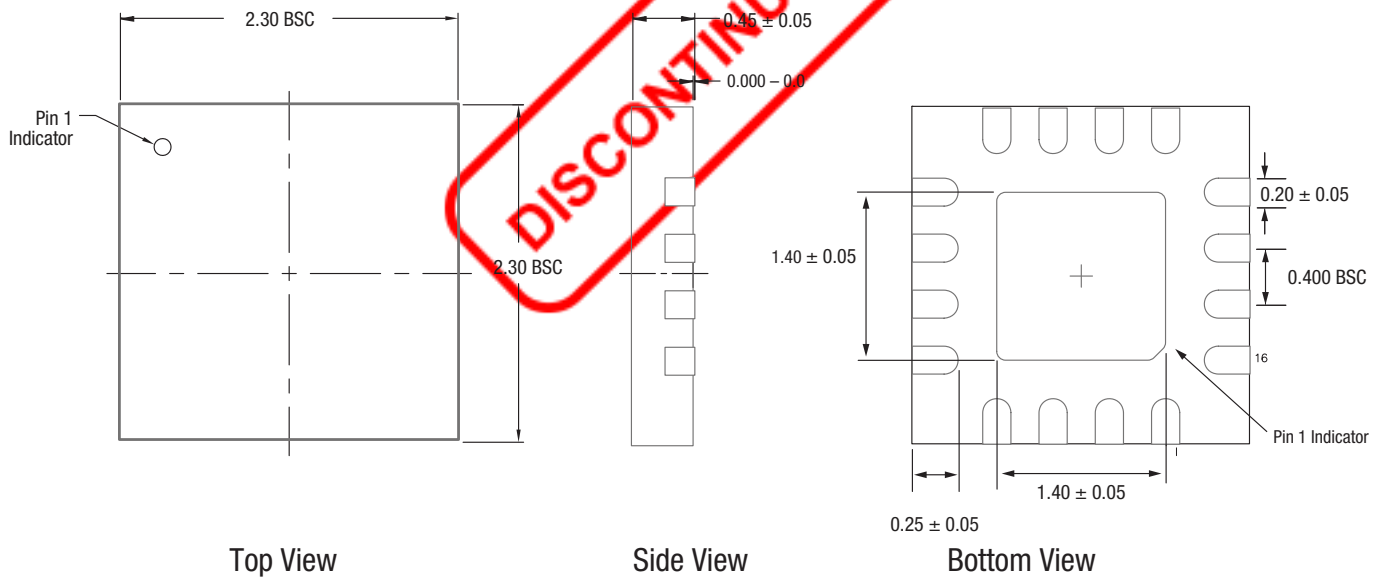

Figure 4. Typical Part Markings (Top View)



All dimensions are in millimeters.

204388-005

Figure 5. RFX8425 Package Dimensions

Ordering Information

Model Name	Manufacturing Part Number	Evaluation Board Part Number
RFX8425: 2.4 GHz CMOS WLAN/Bluetooth® Dual-Mode RFEIC with PA, LNA, and SP3T	RFX8425	RFX8425-EK1



Copyright © 2016,2018 Skyworks Solutions, Inc. All Rights Reserved.

Information in this document is provided in connection with Skyworks Solutions, Inc. (“Skyworks”) products or services. These materials, including the information contained herein, are provided by Skyworks as a service to its customers and may be used for informational purposes only by the customer. Skyworks assumes no responsibility for errors or omissions in these materials or the information contained herein. Skyworks may change its documentation, products, services, specifications or product descriptions at any time, without notice. Skyworks makes no commitment to update the materials or information and shall have no responsibility whatsoever for conflicts, incompatibilities, or other difficulties arising from any future changes.

No license, whether express, implied, by estoppel or otherwise, is granted to any intellectual property rights by this document. Skyworks assumes no liability for any materials, products or information provided hereunder, including the sale, distribution, reproduction or use of Skyworks products, information or materials, except as may be provided in Skyworks Terms and Conditions of Sale.

THE MATERIALS, PRODUCTS AND INFORMATION ARE PROVIDED “AS IS” WITHOUT WARRANTY OF ANY KIND, WHETHER EXPRESS, IMPLIED, STATUTORY, OR OTHERWISE, INCLUDING FITNESS FOR A PARTICULAR PURPOSE OR USE, MERCHANTABILITY, PERFORMANCE, QUALITY OR NON-INFRINGEMENT OF ANY INTELLECTUAL PROPERTY RIGHT; ALL SUCH WARRANTIES ARE HEREBY EXPRESSLY DISCLAIMED. SKYWORKS DOES NOT WARRANT THE ACCURACY OR COMPLETENESS OF THE INFORMATION, TEXT, GRAPHICS OR OTHER ITEMS CONTAINED WITHIN THESE MATERIALS. SKYWORKS SHALL NOT BE LIABLE FOR ANY DAMAGES, INCLUDING BUT NOT LIMITED TO ANY SPECIAL, INDIRECT, INCIDENTAL, STATUTORY, OR CONSEQUENTIAL DAMAGES, INCLUDING WITHOUT LIMITATION, LOST REVENUES OR LOST PROFITS THAT MAY RESULT FROM THE USE OF THE MATERIALS OR INFORMATION, WHETHER OR NOT THE RECIPIENT OF MATERIALS HAS BEEN ADVISED OF THE POSSIBILITY OF SUCH DAMAGE.



Skyworks products are not intended for use in medical, lifesaving or life-sustaining applications, or other equipment in which the failure of the Skyworks products could lead to personal injury, death, physical or environmental damage. Skyworks customers using or selling Skyworks products for use in such applications do so at their own risk and agree to fully indemnify Skyworks for any damages resulting from such improper use or sale.

Customers are responsible for their products and applications using Skyworks products, which may deviate from published specifications as a result of design defects, errors, or operation of products outside of published parameters or design specifications. Customers should include design and operating safeguards to minimize these and other risks. Skyworks assumes no liability for applications assistance, customer product design, or damage to any equipment resulting from the use of Skyworks products outside of stated published specifications or parameters.

Skyworks and the Skyworks symbol are trademarks or registered trademarks of Skyworks Solutions, Inc., in the United States and other countries. Third-party brands and names are for identification purposes only, and are the property of their respective owners. Additional information, including relevant terms and conditions, posted at www.skyworksinc.com, are incorporated by reference.

Looking for pricing, stock, or lifecycle information?

Click below to explore more details on WIN SOURCE:

-  [View RFX8425 on WIN SOURCE](#)
-  [Skyworks Solutions Inc. Information](#)

Optimize Your Supply Chain with WIN SOURCE Solutions

-  Global Sourcing Solution
-  Obsolete Management
-  Cost Control Management
-  Shortage Management
-  Alternative Solution
-  Excess Inventory Management