



**THE DATASHEET OF  
PT7C5006ANDWE**



**Features**

- Up to 107MHz operation
- Capacitors 8pF CG and 16pF CD built-in
- Inverter amplifier feedback resistor built-in
- TTL input level
- 16 mA (VDD = 4.5 V) drive capability
- 4 mA (VDD = 4.5 V) drive capability (PT7C5006AHx)
- Output three-state function
- 2.7 to 5.5 V supply voltage
- Oscillator frequency output
- 8-pin SOIC package (PT7C5006xxxW) and Die form (PT7C5006xxxDE) available

**Application**

- Used for crystal oscillator

**Description**

The PT7C5006 series are crystal oscillator module ICs, that incorporate high-frequency, low current consumption oscillator and output buffer circuits. Highly accurate feedback resistors and high-frequency capacitors are built-in, eliminating the need for external components to make a stable 3rd-harmonic oscillator.

**Ordering Information**

Part no.	Package type
PT7C5006xxxW	SOIC-8
PT7C5006xxxWE	Lead free SOIC-8
PT7C5006xxxDE	DIE

**Note :** Below is the detailed definition of part no.

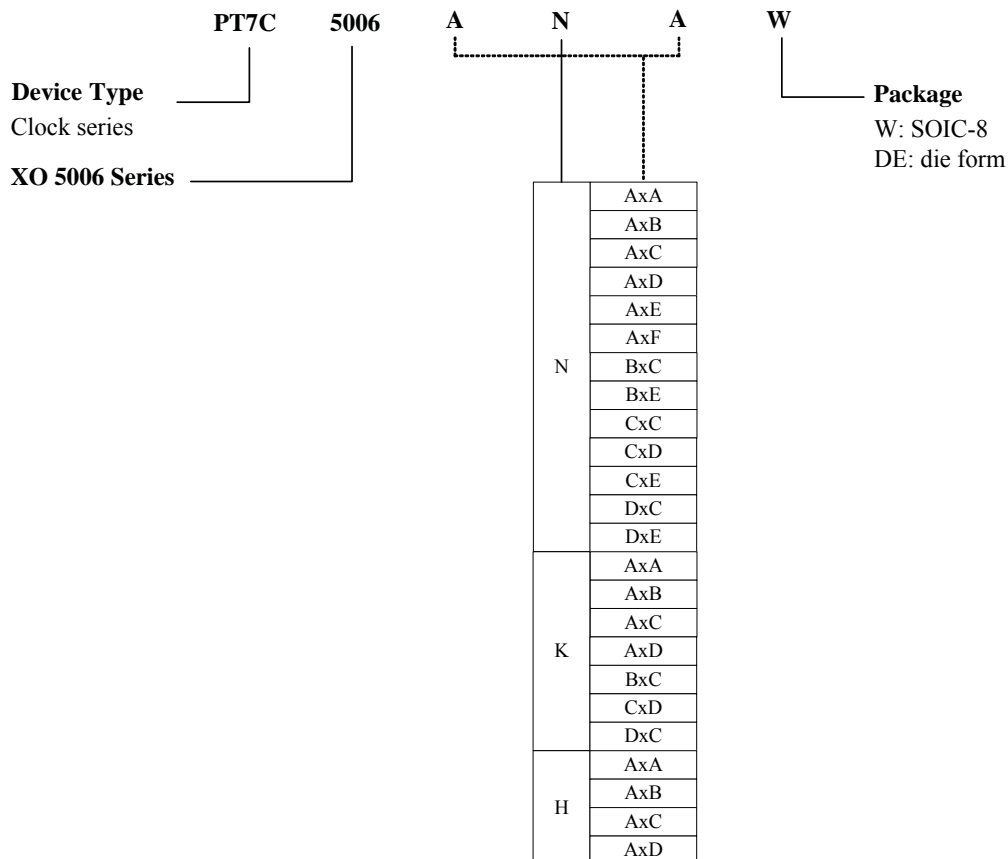

**Series Configuration**

Part No.	g <sub>m</sub> ratio	R <sub>f</sub> (kΩ)	3V operating		5V operating			Built-in capacitance		Input level	Output Duty level				
			Output load (max) (pF)	Recommended Operating Frequency Rang (MHz)	Output load (max) (pF)	Recommended Operating Frequency Rang (MHz)	Output Waveform <sup>2)</sup> t <sub>r</sub> /t <sub>f</sub> (ns)	C <sub>G</sub> (pF)	C <sub>D</sub> (pF)						
PT7C5006ANA	0.5	8.2	-	-	50	22 to 30	8/8	8	16	TTL	CMOS				
PT7C5006ANB	1	5.6	-	-	50	30 to 40	8/8								
PT7C5006ANC	2	4.9	15	22 to 30	50	40 to 60	7/7								
PT7C5006AND	2	2.6	15	30 to 50	50	50 to 70	7/7								
PT7C5006ANE	3	2.6	15	50 to 70	30 15 <sup>1)</sup>	70 to 100	6/6								
PT7C5006ANF	4	2.6	-	-	30 15 <sup>1)</sup>	80 to 107	6/6								
PT7C5006CNC	2	4.9	15	22 to 30	15 50	40 to 60 40 to 50	8/8								
PT7C5006CND	2	2.6	15	30 to 40	15	50 to 70	8/8								
PT7C5006CNE	3	2.6	15	50 to 70	15	70 to 100	7/7								
PT7C5006BNC	2	No	15	22 to 70	15 50	22 to 100 22 to 70	7/7								
PT7C5006BNE	3	No	15	22 to 70	30 15 <sup>1)</sup>	70 to 107	6/6								
PT7C5006DNC	2	No	15	22 to 40	15 50	22 to 70 22 to 50	8/8								
PT7C5006DNE	3	No	15	22 to 70	15 50	22 to 100 22 to 70	7/7								
PT7C5006AKA	0.5	8.2	-	-	15	22 to 30	4/4					8	16	TTL	TTL
PT7C5006AKB	1	5.6	-	-	15	30 to 40									
PT7C5006AKC	2	4.9	-	-	15	40 to 60									
PT7C5006AKD	2	2.6	-	-	15	50 to 70									
PT7C5006CKD	2	2.6	-	-	15	50 to 70									
PT7C5006BKC	2	No	-	-	15	22 to 70									
PT7C5006DKC	2	No	-	-	15	22 to 70									
PT7C5006AHA	0.5	8.2	-	-	15	22 to 30	7/7	8	16	TTL	CMOS				
PT7C5006AHB	1	5.6	-	-	15	30 to 40									
PT7C5006AHC	2	4.9	-	-	15	40 to 60									
PT7C5006AHD	2	2.6	-	-	15	50 to 70									

1): SOIC package only.

2): 5006xNx: C<sub>L</sub>= 50pF, CMOS load

5006xKx: C<sub>L</sub>= 15pF, 10TTL load

5006AHx: C<sub>L</sub>= 15pF, CMOS load

**Note:** Recommend operating frequency is not the guaranteed value but is measured using PTI's standard crystal.

**Block Diagram**

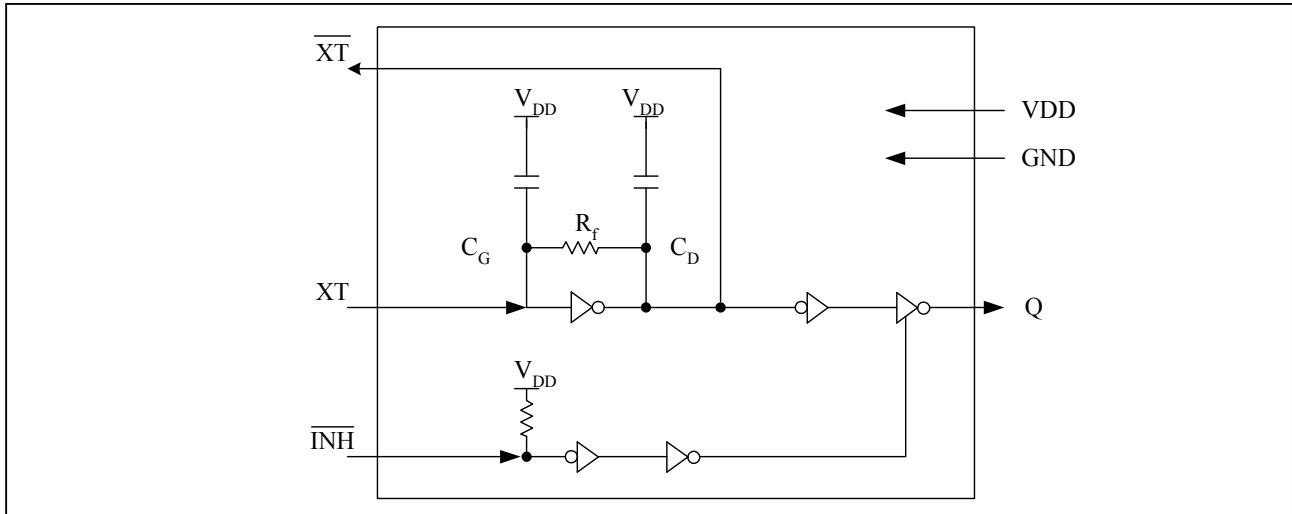

**Pin Configuration**

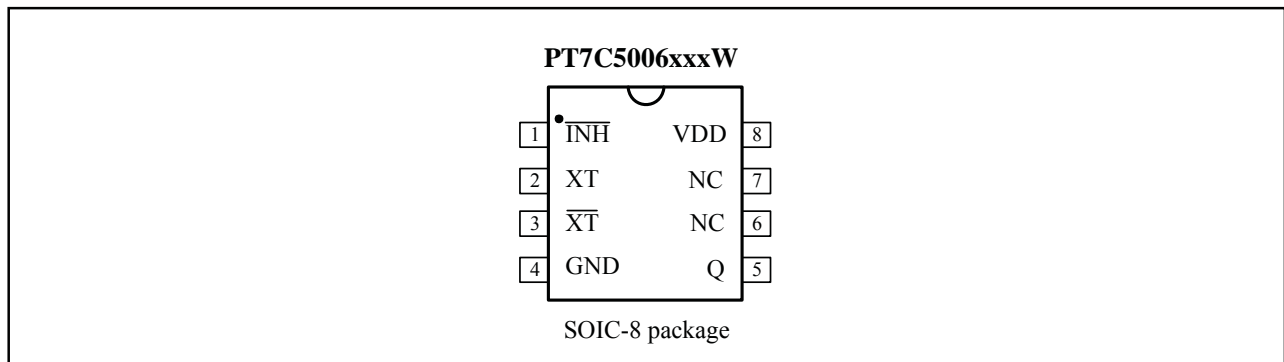

**Pin Description**

Pin	Sym.	Type	Description
1	INH̄	I	Output state control input. High impedance when LOW. Pull-up resistor built in.
2	XT	I	Amplifier input.
3	XT̄	O	Amplifier output.
Crystal oscillator connected between XT and XT̄			
4	GND	P	Ground
5	Q	O	Output. Output frequency (f <sub>0</sub> ).
6,7	NC	-	No connection
8	V <sub>DD</sub>	P	Supply voltage

**Function Description**

When  $\overline{INH}$  goes LOW, the output on Q becomes high impedance, but internally the oscillator does not stop.

$\overline{INH}$	Oscillator	Q
High (or open)	Normal operation	Output $f_o$ frequency
Low	Normal operation	High impedance

**Maximum Ratings**

Storage Temperature (die form).....	-65°C to +150°C
Storage Temperature (package form) .....	-40°C to +125°C
Ambient Temperature with Power Applied.....	-40°C to +85°C
Supply Voltage to Ground Potential ( $V_{DD}$ to GND) .....	-0.5V to 7.0V
Input Voltage (All Inputs except $V_{DD}$ & GND) ....	-0.5V to $V_{DD} + 0.5V$
Output Voltage .....	-0.5V to $V_{DD} + 0.5V$
Output Current (PT7C5006xNx/xKx).....	25mA
Output Current (PT7C5006AHx).....	10mA
Power Dissipation.....	200mW (package form)

**Note:**

Stresses greater than those listed under MAXIMUM RATINGS may cause permanent damage to the device. This is a stress rating only and functional operation of the device at these or any other conditions above those indicated in the operational sections of this specification is not implied. Exposure to absolute maximum rating conditions for extended periods may affect reliability.

**Recommended Operating Conditions**

**PT7C5006 series (package form)**

Sym.	Parameter	Series	Conditions	Min	Typ	Max	Unit
V <sub>DD</sub>	Supply voltage	ANA, ANB, CNC, CND, DNC	f ≤ 50MHz, C <sub>L</sub> =50pF	4.5	-	5.5	V
			f ≤ 70MHz, C <sub>L</sub> =15pF	4.5	-	5.5	
			f ≤ 40MHz, C <sub>L</sub> =15pF	2.7	-	3.6	
		ANC, AND, BNC, CNE, DNE	f ≤ 70MHz, C <sub>L</sub> =50pF	4.5	-	5.5	V
			f ≤ 100MHz, C <sub>L</sub> =15pF	4.5	-	5.5	
			f ≤ 50MHz, C <sub>L</sub> =15pF	2.7	-	3.6	
		ANE, ANF, BNE	f ≤ 70MHz, C <sub>L</sub> =15pF	3.0	-	3.6	V
			f ≤ 100MHz, C <sub>L</sub> =15pF	4.5	-	5.5	
			f ≤ 107MHz, C <sub>L</sub> =15pF	4.5	-	5.5	
		AKA, AKB, AKC, CKD, DKC	f ≤ 50MHz, C <sub>L</sub> =15pF	2.7	-	3.6	V
			f ≤ 70MHz, C <sub>L</sub> =15pF	3.0	-	3.6	
			f ≤ 70MHz, C <sub>L</sub> =15pF	4.5	-	5.5	
AKD, BKC	f ≤ 70MHz, C <sub>L</sub> =15pF	4.5	-	5.5	V		
	f ≤ 70MHz, C <sub>L</sub> =15pF	4.5	-	5.5	V		
AHA, AHB, AHC, AHD	f ≤ 70MHz, C <sub>L</sub> =15pF	4.5	-	5.5	V		
	f ≤ 70MHz, C <sub>L</sub> =15pF	4.5	-	5.5	V		
V <sub>IN</sub>	Input voltage	All series		GND	-	V <sub>DD</sub>	V
T <sub>OPR</sub>	Operating temperature	ANA, ANB, CNC, CND, DNC	f ≤ 50MHz, C <sub>L</sub> =50pF, 4.5 ≤ V <sub>DD</sub> ≤ 5.5	-40	-	80	°C
			f ≤ 70MHz, C <sub>L</sub> =15pF, 4.5 ≤ V <sub>DD</sub> ≤ 5.5	0	-	70	
			f ≤ 40MHz, C <sub>L</sub> =15pF, 2.7 ≤ V <sub>DD</sub> ≤ 3.6	-10	-	70	
		ANC, AND, BNC, CNE, DNE	f ≤ 50MHz, C <sub>L</sub> =50pF, 2.7 ≤ V <sub>DD</sub> ≤ 5.5	-40	-	80	°C
			f ≤ 70MHz, C <sub>L</sub> =50pF, 4.5 ≤ V <sub>DD</sub> ≤ 5.5	-20	-	80	
			f ≤ 70MHz, C <sub>L</sub> =15pF, 4.5 ≤ V <sub>DD</sub> ≤ 5.5	-40	-	85	
			f ≤ 100MHz, C <sub>L</sub> =15pF, 4.5 ≤ V <sub>DD</sub> ≤ 5.5	0	-	70	
			f ≤ 50MHz, C <sub>L</sub> =15pF, 2.7 ≤ V <sub>DD</sub> ≤ 3.6	-20	-	80	
			f ≤ 70MHz, C <sub>L</sub> =15pF, 3.0 ≤ V <sub>DD</sub> ≤ 3.6	-20	-	80	
		ANE, ANF, BNE	f ≤ 70MHz, C <sub>L</sub> =50pF, 4.5 ≤ V <sub>DD</sub> ≤ 5.5	-20	-	80	°C
			f ≤ 100MHz, C <sub>L</sub> =15pF, 4.5 ≤ V <sub>DD</sub> ≤ 5.5	-40	-	85	
			f ≤ 107MHz, C <sub>L</sub> =15pF, 4.5 ≤ V <sub>DD</sub> ≤ 5.5	-20	-	80	
			f ≤ 50MHz, C <sub>L</sub> =15pF, 2.7 ≤ V <sub>DD</sub> ≤ 3.6	-20	-	80	
			f ≤ 70MHz, C <sub>L</sub> =15pF, 3.0 ≤ V <sub>DD</sub> ≤ 3.6	-20	-	80	
		AKA, AKB, AKC, CKD, DKC	f ≤ 50MHz, C <sub>L</sub> =15pF, 4.5 ≤ V <sub>DD</sub> ≤ 5.5	-40	-	85	°C
			f ≤ 70MHz, C <sub>L</sub> =15pF, 4.5 ≤ V <sub>DD</sub> ≤ 5.5	0	-	70	
		AKD, BKC	f ≤ 50MHz, C <sub>L</sub> =15pF, 4.5 ≤ V <sub>DD</sub> ≤ 5.5	-40	-	85	°C
			f ≤ 70MHz, C <sub>L</sub> =15pF, 4.5 ≤ V <sub>DD</sub> ≤ 5.5	-20	-	80	
		AHA, AHB, AHC, AHD	f ≤ 50MHz, C <sub>L</sub> =15pF, 4.5 ≤ V <sub>DD</sub> ≤ 5.5	-40	-	85	°C
			f ≤ 70MHz, C <sub>L</sub> =15pF, 4.5 ≤ V <sub>DD</sub> ≤ 5.5	-15	-	75	

PT7C5006 series (die form)

Sym.	Parameter	Series	Condition	Min	Typ	Max	Unit
V <sub>DD</sub>	Supply voltage	ANA, ANB, CNC, CND, DNC	f ≤ 50MHz, C <sub>L</sub> =50pF	4.5	-	5.5	V
			f ≤ 70MHz, C <sub>L</sub> =15pF	4.5	-	5.5	
			f ≤ 40MHz, C <sub>L</sub> =15pF	2.7	-	3.6	
		ANC, AND, BNC, CNE, DNE	f ≤ 70MHz, C <sub>L</sub> =50pF	4.5	-	5.5	V
			f ≤ 100MHz, C <sub>L</sub> =15pF	4.5	-	5.5	
			f ≤ 50MHz, C <sub>L</sub> =15pF	2.7	-	3.6	
		ANE, ANF, BNE	f ≤ 70MHz, C <sub>L</sub> =15pF	3.0	-	3.6	V
			f ≤ 100MHz, C <sub>L</sub> =15pF	4.5	-	5.5	
			f ≤ 10.7MHz, C <sub>L</sub> =15pF	4.5	-	5.5	
		AKA, AKB, AKC, CKD, DKC	f ≤ 70MHz, C <sub>L</sub> =15pF	4.5	-	5.5	V
			AKD, BKC	f ≤ 70MHz, C <sub>L</sub> =15pF	4.5	-	5.5
		AHA, AHB, AHC, AHD	f ≤ 70MHz, C <sub>L</sub> =15pF	4.5	-	5.5	V
V <sub>IN</sub>	Input voltage	All series		GND	-	V <sub>DD</sub>	V
T <sub>OPR</sub>	Operating temperature	ANA, ANB, CNC, CND, DNC	f ≤ 50MHz, C <sub>L</sub> =50pF, 4.5 ≤ V <sub>DD</sub> ≤ 5.5	-40	-	80	°C
			f ≤ 70MHz, C <sub>L</sub> =15pF, 4.5 ≤ V <sub>DD</sub> ≤ 5.5	-15	-	75	
			f ≤ 40MHz, C <sub>L</sub> =15pF, 2.7 ≤ V <sub>DD</sub> ≤ 3.6	-10	-	70	
		ANC, AND, BNC, CNE, DNE	f ≤ 70MHz, C <sub>L</sub> =50pF, 4.5 ≤ V <sub>DD</sub> ≤ 5.5	-40	-	85	°C
			f ≤ 100MHz, C <sub>L</sub> =15pF, 4.5 ≤ V <sub>DD</sub> ≤ 5.5	-20	-	80	
			f ≤ 50MHz, C <sub>L</sub> =15pF, 2.7 ≤ V <sub>DD</sub> ≤ 3.6	-20	-	80	
		ANE, ANF, BNE	f ≤ 70MHz, C <sub>L</sub> =15pF, 2.7 ≤ V <sub>DD</sub> ≤ 3.6	-20	-	80	°C
			f ≤ 70MHz, C <sub>L</sub> =50pF, 4.5 ≤ V <sub>DD</sub> ≤ 5.5	-40	-	85	
			f ≤ 100MHz, C <sub>L</sub> =30pF, 4.5 ≤ V <sub>DD</sub> ≤ 5.5	-40	-	85	
		AKA, AKB, AKC, CKD, DKC	f ≤ 107MHz, C <sub>L</sub> =30pF, 4.5 ≤ V <sub>DD</sub> ≤ 5.5	-20	-	80	°C
			f ≤ 50MHz, C <sub>L</sub> =15pF, 2.7 ≤ V <sub>DD</sub> ≤ 3.6	-20	-	80	
		AKD, BKC	f ≤ 70MHz, C <sub>L</sub> =15pF, 3.0 ≤ V <sub>DD</sub> ≤ 3.6	-20	-	80	°C
			f ≤ 50MHz, C <sub>L</sub> =15pF, 4.5 ≤ V <sub>DD</sub> ≤ 5.5	-40	-	85	
		AHA, AHB, AHC, AHD	f ≤ 70MHz, C <sub>L</sub> =15pF, 4.5 ≤ V <sub>DD</sub> ≤ 5.5	-15	-	75	°C
			f ≤ 50MHz, C <sub>L</sub> =15pF, 4.5 ≤ V <sub>DD</sub> ≤ 5.5	-40	-	85	
			f ≤ 70MHz, C <sub>L</sub> =15pF, 4.5 ≤ V <sub>DD</sub> ≤ 5.5	-40	-	85	°C
			f ≤ 70MHz, C <sub>L</sub> =15pF, 4.5 ≤ V <sub>DD</sub> ≤ 5.5	-20	-	80	
			f ≤ 50MHz, C <sub>L</sub> =15pF, 4.5 ≤ V <sub>DD</sub> ≤ 5.5	-40	-	85	°C
			f ≤ 70MHz, C <sub>L</sub> =15pF, 4.5 ≤ V <sub>DD</sub> ≤ 5.5	-20	-	80	
			f ≤ 50MHz, C <sub>L</sub> =15pF, 4.5 ≤ V <sub>DD</sub> ≤ 5.5	-40	-	85	°C
			f ≤ 70MHz, C <sub>L</sub> =15pF, 4.5 ≤ V <sub>DD</sub> ≤ 5.5	-20	-	80	

**DC Electrical Characteristics**

**PT7C5006×N series**

**3V operation:**  $V_{DD} = 2.7$  to  $3.6V$ ,  $T_A = -20$  to  $80^\circ C$  unless otherwise noted.

Sym.	Parameter	Condition		Min	Typ	Max	Unit
$I_{DD}$	Current consumption	$\overline{INH}$ =open, Measurement cct 3, Load cct 1, $V_{DD}=3.0$ to $3.6V$ , $C_L=15pF$	f=30MHz PT7C5006ANC PT7C5006BNC	-	8	16	mA
			f=30MHz, $T_A = -10$ to $70^\circ C$ PT7C5006CNC	-	8	16	
			f=50MHz PT7C5006AND	-	13	26	
			f=70MHz PT7C5006BNE PT7C5006CNE PT7C5006DNE	-	15	30	
			f=40MHz, $T_A = -10$ to $70^\circ C$ PT7C5006CND PT7C5006DNC	-	11	22	
			f=70MHz PT7C5006ANE PT7C5006ANF	-	20	40	
$V_{IH}$	High-level input voltage	$\overline{INH}$		2.0	-	-	V
$V_{IL}$	Low-level input voltage	$\overline{INH}$		-	-	0.5	V
$R_{up}$	$\overline{INH}$ pull-up resistance	Measurement cct 4		50	-	150	k $\Omega$
$R_f$	Feedback resistance	Measurement cct 5	PT7C5006ANA	6.97	8.2	9.43	k $\Omega$
			PT7C5006ANB	4.76	5.6	6.44	
			PT7C5006ANC, PT7C5006CNC	4.16	4.9	5.64	
			PT7C5006AND, PT7C5006ANE, PT7C5006ANF, PT7C5006CND, PT7C5006CNE	2.21	2.6	2.99	
$C_G$	Built-in capacitance	Design value, determined by the value internal pattern		7.44	8	8.56	pF
$C_D$		Design value, determined by the value internal pattern		14.88	16	17.12	
$V_{OH}$	High-level output voltage	Q: Measurement cct 1, $V_{DD}=2.7V$ , $I_{OH}=8mA$		2.2	2.4	-	V
$V_{OL}$	Low-level output voltage	Q: Measurement cct 2, $V_{DD}=2.7V$ , $I_{OL}=8mA$		-	0.3	0.4	V
$I_Z$	Output leakage current	Q: Measurement cct 2, $\overline{INH}=LOW$ , $V_{DD}=5.5V$	$V_{OH} = V_{DD}$	-	-	10	$\mu A$
			$V_{OL} = GND$	-	-	10	

PT7C5006xN series

5V operation:  $V_{DD}=4.5$  to  $5.5V$ ,  $T_A=-40$  to  $85^\circ C$  unless otherwise noted.

Sym.	Parameter	Condition	Min	Typ	Max	Unit	
I <sub>DD</sub>	Current consumption	$\overline{INH}$ =open, Measurement cct 3, Load cct 1, $V_{DD}=4.5$ to $5.5V$ , $C_L=50pF$	f = 30MHz PT7C5006ANA	-	18	35	mA
			f = 40MHz, PT7C5006ANB	-	20	40	
			f = 60MHz PT7C5006ANCDE	-	30	60	
			f = 60MHz, $T_A=-20$ to $80^\circ C$ PT7C5006ANCW	-	30	50	
			f = 70MHz PT7C5006ANDDE PT7C5006BNCDE	-	40	80	
			f = 70MHz, $T_A=-20$ to $80^\circ C$ PT7C5006ANDW PT7C5006BNCW	-	40	70	
		$\overline{INH}$ =open, Measurement cct 3, Load cct 1, $V_{DD}=4.5$ to $5.5V$	f = 60MHz, $C_L=15pF$ $T_A=-15$ to $75^\circ C$ PT7C5006CNCDE	-	28	50	
			f = 60MHz, $C_L=15pF$ $T_A=0$ to $70^\circ C$ PT7C5006CNCW	-	28	50	
			f = 70MHz, $C_L=15pF$ $T_A=-15$ to $75^\circ C$ PT7C5006CNDDE PT7C5006DNCDE	-	35	65	
			f = 70MHz, $C_L=15pF$ $T_A=0$ to $70^\circ C$ PT7C5006CNDW PT7C5006DNCW	-	35	65	
			f = 100MHz, $C_L=15pF$ $T_A=-20$ to $80^\circ C$ PT7C5006CNEDE PT7C5006DNEDE	-	45	80	
			f = 100MHz, $C_L=15pF$ $T_A=0$ to $70^\circ C$ PT7C5006CNEW PT7C5006DNEW	-	45	80	
			f = 100MHz, $C_L=30pF$ PT7C5006ANEDE	-	50	100	
			f = 100MHz, $C_L=15pF$ PT7C5006ANEW	-	45	90	
f = 107MHz, $C_L=30pF$ $T_A=-20$ to $80^\circ C$ PT7C5006ANFDE PT7C5006BNEDE	-	60	100				
f = 107MHz, $C_L=15pF$ $T_A=-20$ to $80^\circ C$ PT7C5006ANFW PT7C5006BNEW	-	50	90				
V <sub>IH</sub>	High-level input voltage	$\overline{INH}$	2.0	-	-	V	
V <sub>IL</sub>	Low-level input voltage	$\overline{INH}$	-	-	0.8	V	
R <sub>up</sub>	$\overline{INH}$ pull-up resistance	Measurement cct 4	50	-	150	k $\Omega$	
R <sub>f</sub>	Feedback resistance	Measurement cct 5	PT7C5006ANA	6.97	8.2	9.43	k $\Omega$
			PT7C5006ANB	4.76	5.6	6.44	
			PT7C5006ANC, PT7C5006CNC	4.16	4.9	5.64	
			PT7C5006AND, PT7C5006ANES, PT7C5006ANF, PT7C5006CND, PT7C5006CNE	2.21	2.6	2.99	
C <sub>G</sub>	Built-in capacitance	Design value, determined by the value internal pattern	7.44	8	8.56	pF	
C <sub>D</sub>		Design value, determined by the value internal pattern	14.88	16	17.12		
V <sub>OH</sub>	High-level output voltage	Q: Measurement cct 1, $V_{DD}=4.5V, I_{OH}=16mA$	4.0	4.2	-	V	
V <sub>OL</sub>	Low-level output voltage	Q: Measurement cct 2, $V_{DD}=4.5V, I_{OL}=16mA$	-	0.3	0.4	V	
I <sub>Z</sub>	Output leakage current	Q: Measurement cct 2, $\overline{INH}=LOW,$ $V_{DD}=5.5V$	$V_{OH} = V_{DD}$	-	-	10	$\mu A$
			$V_{OL} = GND$	-	-	10	

PT7C5006xK series

$V_{DD} = 4.5$  to  $5.5V$ ,  $T_A = -40$  to  $85^\circ C$  unless otherwise noted.

Sym.	Parameter	Condition		Min	Typ	Max	Unit
I <sub>DD</sub>	Current consumption	$\overline{INH}$ = open, Measurement cct 3, Load cct 1, $V_{DD} = 4.5$ to $5.5V$ , $C_L = 15pF$	f=30MHz PT7C5006AKA	-	16	32	mA
			f=40MHz PT7C5006AKB	-	18	36	
			f=60MHz, $T_A = -15$ to $75^\circ C$ PT7C5006AKCDE PT7C5006DKCDE	-	25	50	
			f=60MHz, $T_A = 0$ to $70^\circ C$ PT7C5006AKCW PT7C5006DKCW	-	25	50	
			f=70MHz, $T_A = -20$ to $80^\circ C$ PT7C5006AKDDE PT7C5006BKCDE	-	35	70	
			f=70MHz, $T_A = -15$ to $75^\circ C$ PT7C5006CKDDE	-	35	70	
			f=70MHz, $T_A = 0$ to $70^\circ C$ PT7C5006AKDW PT7C5006BKCW PT7C5006CKDW	-	35	70	
V <sub>IH</sub>	High-level input voltage	$\overline{INH}$		2.0	-	-	V
V <sub>IL</sub>	Low-level input voltage	$\overline{INH}$		-	-	0.8	V
R <sub>up</sub>	$\overline{INH}$ pull-up resistance	Measurement cct 4		50	-	150	k $\Omega$
R <sub>f</sub>	Feedback resistance	Measurement cct 5	PT7C5006AKA	6.97	8.2	9.43	k $\Omega$
			PT7C5006AKB	4.76	5.6	6.44	
			PT7C5006AKC	4.16	4.9	5.64	
			PT7C5006AKD, PT7C5006CKD	2.21	2.6	2.99	
C <sub>G</sub>	Built-in capacitance	Design value, determined by the value internal pattern		7.44	8	8.56	pF
C <sub>D</sub>		Design value, determined by the value internal pattern		14.88	16	17.12	
V <sub>OH</sub>	High-level output voltage	Q: Measurement cct 1, $V_{DD} = 4.5V$ , $I_{OH} = 16mA$	PT7C5006AKA, PT7C5006AKB PT7C5006AKC, PT7C5006CKD, PT7C5006DKC	3.9	4.2	-	V
			PT7C5006AKD, PT7C5006BKC	4.0	4.2	-	
V <sub>OL</sub>	Low-level output voltage	Q: Measurement cct 2, $V_{DD} = 4.5V$ , $I_{OL} = 16mA$		-	0.3	0.4	V
I <sub>Z</sub>	Output leakage current	Q: Measurement cct 2, $\overline{INH} = LOW$ , $V_{DD} = 5.5V$	$V_{OH} = V_{DD}$	-	-	10	$\mu A$
			$V_{OL} = V_{SS}$	-	-	10	

**PT7C5006AH series**

$V_{DD} = 4.5$  to  $5.5V$ ,  $T_A = -40$  to  $85^{\circ}C$  unless otherwise noted.

Sym.	Parameter	Condition		Min	Typ	Max	Unit	
$I_{DD}$	Current consumption	$\overline{INH}$ =open, Measurement cct 3, Load cct 1, $V_{DD} = 4.5$ to $5.5V$ , $C_L = 15pF$	$f = 30MHz$	PT7C5006AHA	-	15	30	mA
			$f = 40MHz$ ,	PT7C5006AHB	-	18	36	
			$f = 60MHz$ , $T_A = -20$ to $80^{\circ}C$	PT7C5006AHCDE	-	25	50	
			$f = 60MHz$ , $T_A = -15$ to $75^{\circ}C$	PT7C5006AHCW	-	25	50	
			$f = 70MHz$ , $T_A = -20$ to $80^{\circ}C$	PT7C5006AHDDE	-	32	65	
			$f = 70MHz$ , $T_A = -15$ to $75^{\circ}C$	PT7C5006AHDW	-	32	65	
$V_{IH}$	High-level input voltage	$\overline{INH}$		2.0	-	-	V	
$V_{IL}$	Low-level input voltage	$\overline{INH}$		-	-	0.8	V	
$R_{up}$	$\overline{INH}$ pull-up resistance	Measurement cct 4		50	-	150	k $\Omega$	
$R_f$	Feedback resistance	Measurement cct 5	PT7C5006AHA	6.97	8.2	9.43	k $\Omega$	
			PT7C5006AHB	4.76	5.6	6.44		
			PT7C5006AHC	4.16	4.9	5.64		
			PT7C5006AHD	2.21	2.6	2.99		
$C_G$	Built-in capacitance	Design value, determined by the value internal pattern		7.44	8	8.56	pF	
$C_D$		Design value, determined by the value internal pattern		14.88	16	17.12		
$V_{OH}$	High-level output voltage	Q: Measurement cct 1, $V_{DD} = 4.5V, I_{OH} = 4mA$		3.9	4.2	-	V	
$V_{OL}$	Low-level output voltage	Q: Measurement cct 2, $V_{DD} = 4.5V, I_{OL} = 4mA$		-	0.3	0.5	V	
$I_Z$	Output leakage current	Q: Measurement cct 2, $\overline{INH} = LOW$ , $V_{DD} = 5.5V$		$V_{OH} = V_{DD}$	-	-	10	$\mu A$
				$V_{OL} = GND$	-	-	10	

**AC Electrical Characteristics**

**Output duty level (CMOS)**

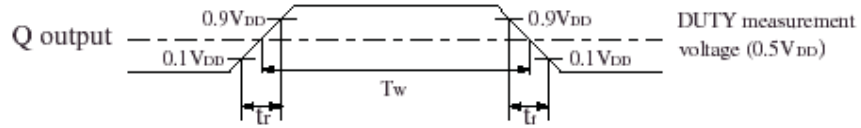

**Output duty level (TTL)**

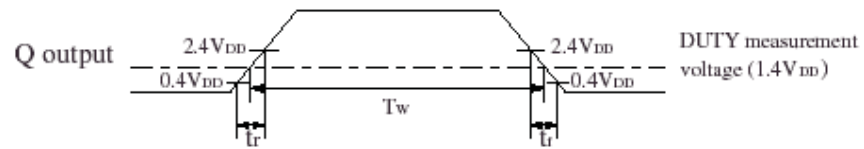

**Output duty cycle (CMOS)**

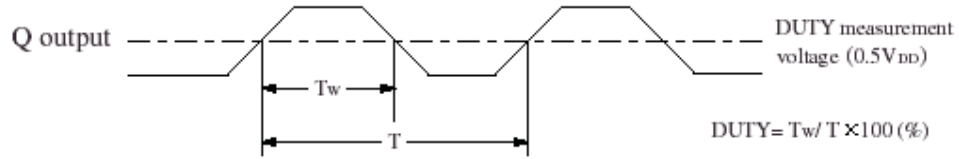

**Output duty cycle (TTL)**

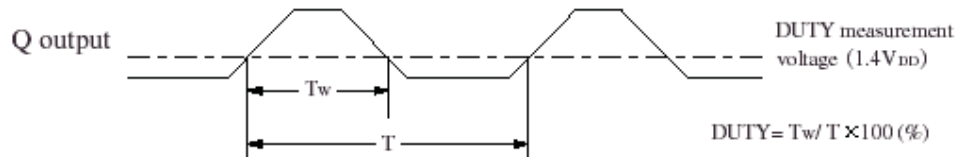

PT7C5006xN series

3V operation:  $V_{DD} = 2.7$  to  $3.6V$ ,  $T_A = -20$  to  $80^\circ C$ , unless otherwise noted.

Sym.	Parameter	Condition		Min	Typ	Max	Unit	
t <sub>r</sub>	Output rise time	Measurement cct 3, Load cct 1, $0.1V_{DD}$ to $0.9V_{DD}$ , $C_L = 15pF$	$T_A = -10$ to $70^\circ C$	PT7C5006ANA, PT7C5006ANB, PT7C5006CNC, PT7C5006CND, PT7C5006DNC	-	3.5	7.0	ns
				PT7C5006ANC, PT7C5006AND, PT7C5006ANE, PT7C5006ANF, PT7C5006BNC, PT7C5006BNE, PT7C5006CNE, PT7C5006DNE	-	3.5	7.0	
t <sub>f</sub>	Output fall time	Measurement cct 3, Load cct 1, $0.9V_{DD}$ to $0.1V_{DD}$ , $C_L = 15pF$	$T_A = -10$ to $70^\circ C$	PT7C5006ANA, PT7C5006ANB, PT7C5006CNC, PT7C5006CND, PT7C5006DNC	-	3.5	7.0	ns
				PT7C5006ANC, PT7C5006AND, PT7C5006ANE, PT7C5006ANF, PT7C5006BNC, PT7C5006BNE, PT7C5006CNE, PT7C5006DNE	-	3.5	7.0	
Duty	Output duty cycle*1	Measurement cct 3, Load cct 1, $T_A = 25^\circ C$ , $V_{DD} = 3.3V$ , $C_L = 15pF$	f = 30MHz	PT7C5006ANA, PT7C5006ANB, PT7C5006ANC, PT7C5006CNC	40	-	60	%
			f = 40MHz	PT7C5006CND, PT7C5006DNC	40	-	60	
			f = 50MHz	PT7C5006AND, PT7C5006BNC	40	-	60	
			f = 70MHz	PT7C5006ANE, PT7C5006ANF, PT7C5006BNE, PT7C5006CNE, PT7C5006DNE	40	-	60	
t <sub>PLZ</sub>	Output disable delay time	Measurement cct 3, Load cct 1, $T_A = 25^\circ C$ , $V_{DD} = 5V$ , $C_L \leq 15pF$		-	-	100	ns	
t <sub>PZL</sub>	Output enable delay time	Measurement cct 3, Load cct 1, $T_A = 25^\circ C$ , $V_{DD} = 5V$ , $C_L \leq 15pF$		-	-	100	ns	

PT7C5006xN series

5V operation:  $V_{DD}=4.5$  to  $5.5V$ ,  $T_A=-40$  to  $85^\circ C$  unless otherwise noted.

Sym.	Parameter	Condition		Min	Typ	Max	Unit	
$t_r$	Output rise time	Measurement cct 3, Load cct 1, $0.1V_{DD}$ to $0.9V_{DD}$	$C_L = 15pF$	PT7C5006ANA, PT7C5006ANB, PT7C5006CNC, PT7C5006CND, PT7C5006DNC	-	2.0	4.0	ns
				PT7C5006ANC, PT7C5006AND, PT7C5006BNC, PT7C5006CNE, PT7C5006DNE	-	1.5	3.0	
			$C_L = 30pF$	PT7C5006ANEDE, PT7C5006ANFDE, PT7C5006BNEDE	-	2.0	4.0	
				$C_L = 50pF$	PT7C5006ANA, PT7C5006ANB, PT7C5006CNC, PT7C5006CND, PT7C5006DNC	-	4.0	
			PT7C5006ANC, PT7C5006AND, PT7C5006BNC, PT7C5006CNE, PT7C5006DNE		-	3.5	7.0	
			PT7C5006ANE, PT7C5006ANF, PT7C5006BNE		-	3.0	6.0	
$t_f$	Output fall time	Measurement cct 3, Load cct 1, $0.9V_{DD}$ to $0.1V_{DD}$	$C_L = 15pF$	PT7C5006ANA, PT7C5006ANB, PT7C5006CNC, PT7C5006CND, PT7C5006DNC	-	2.0	4.0	ns
				PT7C5006ANC, PT7C5006AND, PT7C5006BNC, PT7C5006CNE, PT7C5006DNE	-	1.5	3.0	
			$C_L = 30pF$	PT7C5006ANEDE, PT7C5006ANFDE, PT7C5006BNEDE	-	2.0	4.0	
				$C_L = 50pF$	PT7C5006ANA, PT7C5006ANB, PT7C5006CNC, PT7C5006CND, PT7C5006DNC	-	4.0	
			PT7C5006ANC, PT7C5006AND, PT7C5006BNC, PT7C5006CNE, PT7C5006DNE		-	3.5	7.0	
			PT7C5006ANE, PT7C5006ANF, PT7C5006BNE		-	3.0	6.0	

-- to be continued --

-----

-- to be continued --

Sym.	Parameter	Condition		Min	Typ	Max	Unit	
Duty	Output duty cycle	Measurement cct 3, Load cct 1, $T_A = 25^\circ\text{C}$ , $V_{DD} = 5.0\text{V}$	f = 30MHz, $C_L = 50\text{pF}$	PT7C5006ANA	45	-	55	%
			f = 40MHz, $C_L = 50\text{pF}$	PT7C5006ANB	45	-	55	
			f = 60MHz, $C_L = 50\text{pF}$	PT7C5006ANC	45	-	55	
			f = 70MHz, $C_L = 50\text{pF}$	PT7C5006AND, PT7C5006BNC	45	-	55	
			f = 100MHz, $C_L = 30\text{pF}$	PT7C5006ANEDE	45	-	55	
			f = 100MHz, $C_L = 15\text{pF}$	PT7C5006ANEW	45	-	55	
			f = 107MHz, $C_L = 30\text{pF}$	PT7C5006ANFDE PT7C5006BNEDE	45	-	55	
			f = 107MHz, $C_L = 15\text{pF}$	PT7C5006ANFW PT7C5006BNEW	45	-	55	
			f = 50MHz, $C_L = 50\text{pF}$	PT7C5006CNC PT7C5006DNC	45	-	55	
			f = 100MHz, $C_L = 15\text{pF}$	PT7C5006CNE PT7C5006DNE	45	-	55	
			f = 60MHz, $C_L = 15\text{pF}$	PT7C5006CNC	40	-	60	
			f = 70MHz, $C_L = 15\text{pF}$	PT7C5006CND PT7C5006DNC	40	-	60	
$t_{PLZ}$	Output disable delay time	Measurement cct 3, Load cct 1, $T_A = 25^\circ\text{C}$ , $V_{DD} = 5\text{V}$ , $C_L \leq 15\text{pF}$		-	-	100	ns	
$t_{PZL}$	Output enable delay time	Measurement cct 3, Load cct 1, $T_A = 25^\circ\text{C}$ , $V_{DD} = 5\text{V}$ , $C_L \leq 15\text{pF}$		-	-	100	ns	

**PT7C5006×K series**

**5V operation:**  $V_{DD} = 4.5$  to  $5.5V$ ,  $T_A = -40$  to  $85^\circ C$  unless otherwise noted.

Sym.	Parameter	Condition		Min	Typ	Max	Unit	
$t_r$	Output rise time	Measurement cct 3, Load cct 1, 0.4V to 2.4V, $V_{DD} = 4.5$ to $5.5V$	$C_L = 15pF$	-	2	4	ns	
			$C_L = 50pF$	-	-	7		
$t_f$	Output fall time	Measurement cct 3, Load cct1, 2.4V to 0.4V, $V_{DD} = 4.5$ to $5.5V$	$C_L = 15pF$	-	2	4	ns	
			$C_L = 50pF$	-	-	7		
Duty	Output duty cycle	Measurement cct 3, Load cct 1, $T_A = 25^\circ C$ , $V_{DD} = 5.0V$ , $C_L = 15pF$	f = 30MHz	PT7C5006AKA	45	-	55	%
			f = 40MHz	PT7C5006AKB	45	-	55	
			f = 60MHz	PT7C5006AKC	40	-	60	
			f = 70MHz	PT7C5006AKD PT7C5006BKC	45	-	55	
			f = 50MHz	PT7C5006DKC	45	-	55	
			f = 70MHz	PT7C5006CKD PT7C5006DKC	40	-	60	
$t_{PLZ}$	Output disable delay time	Measurement cct 3, Load cct 1, $T_A = 25^\circ C$ ,		-	-	100	ns	
$t_{PZL}$	Output enable delay time	$V_{DD} = 5V, C_L \leq 15PF$		-	-	100	ns	

**PT7C5006AH series**

$V_{DD} = 4.5$  to  $5.5V$ ,  $T_A = -40$  to  $85^\circ C$  unless otherwise noted.

Sym.	Parameter	Condition		Min	Typ	Max	Unit	
$t_r$	Output rise time	Measurement cct 3, Load cct 1, $0.1 V_{DD}$ to $0.9V_{DD}$	$C_L = 15pF$	-	5.0	7.0	ns	
			$C_L = 50pF$	-	13	21		
$t_f$	Output fall time	Measurement cct 3, Load cct 1, $0.9 V_{DD}$ to $0.1V_{DD}$	$C_L = 15pF$	-	5.0	7.0	ns	
			$C_L = 50pF$	-	13	21		
Duty	Output duty cycle *1	Measurement cct 3, Load cct 1, $T_A = 25^\circ C$ , $V_{DD} = 5.0V$ , $C_L = 15pF$	f = 30MHz	PT7C5006AHA	45	-	55	%
			f = 40MHz	PT7C5006AHB	45	-	55	
			f = 50MHz	PT7C5006AHC	45	-	55	
			f = 60MHz $T_A = -20$ to $80^\circ C$	PT7C5006AHCDE	40	-	60	
			f = 60MHz $T_A = -15$ to $75^\circ C$	PT7C5006AHCW	40	-	60	
			f = 70MHz $T_A = -20$ to $80^\circ C$	PT7C5006AHDDE	40	-	60	
			f = 70MHz $T_A = -15$ to $75^\circ C$	PT7C5006AHDW	40	-	60	
$t_{PLZ}$	Output disable delay time	Measurement cct 3, Load cct 1, $T_A = 25^\circ C$ ,		-	-	100	ns	
$t_{PZL}$	Output enable delay time	$V_{DD} = 5V, C_L \leq 15PF$		-	-	100	ns	

**Measurement Circuit**

Measurement cct 1

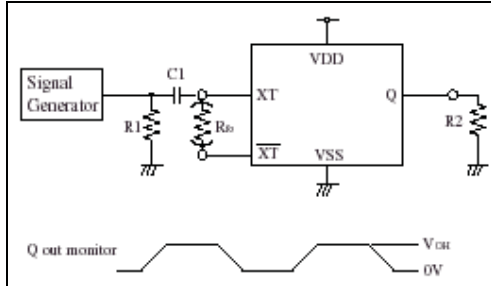

3.5V<sub>P-P</sub>, 10MHz sine wave input signal (5V operation)  
 2.0V<sub>P-P</sub>, 10MHz sine wave input signal (3V operation)  
 C1: 0.001 μ F  
 R1: 50Ω  
 R2: 250Ω (5006×N ×/5V operation)  
 275Ω (5006×N ×/3V operation)  
 245Ω (5006AKA, AKB, AKC, CKD, DKC)  
 250Ω (5006AKD, BKC)  
 975Ω (5006AH×)  
 R<sub>fo</sub> : 2.7kΩ (5006B××, D××)

Measurement cct 3

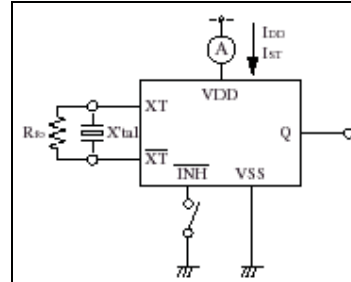

R<sub>fo</sub>: 2.7kΩ (5006B××, D××)

Measurement cct 4

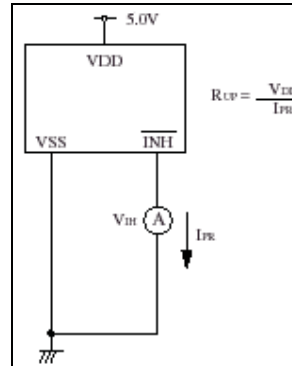

Measurement cct 2

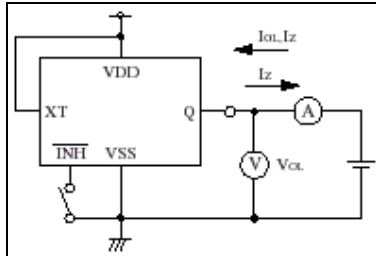

Measurement cct 5

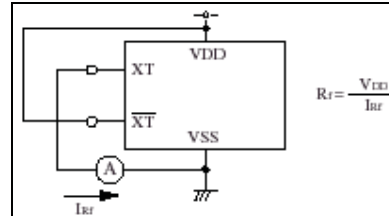

Load cct 1

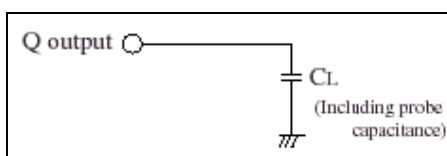

Load cct 2

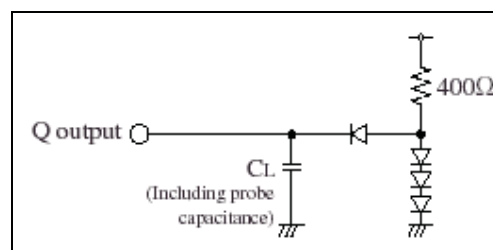

**Mechanical Information**

W/WE (SOIC-8)

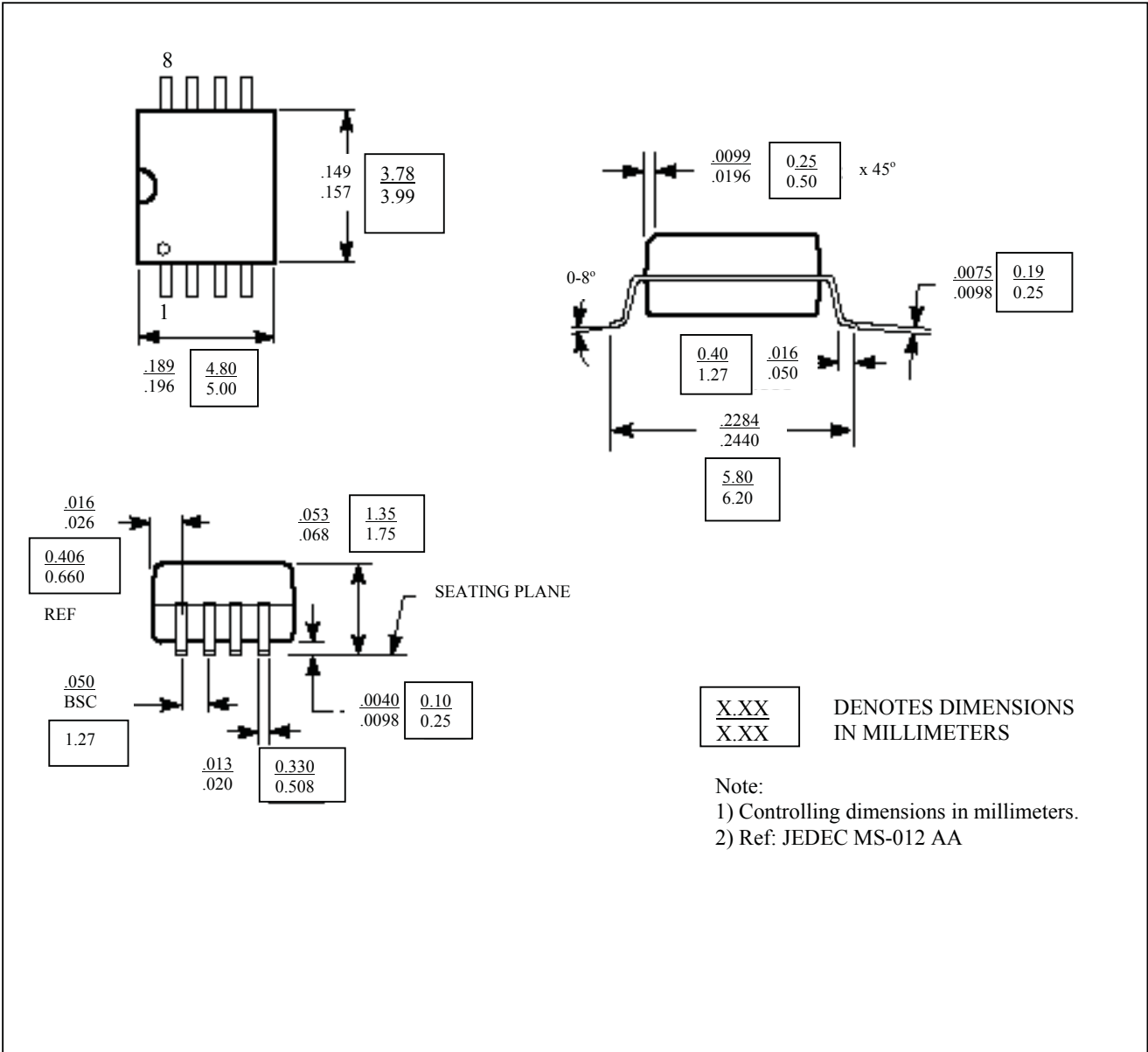

**Pad Location of PT7C5006**

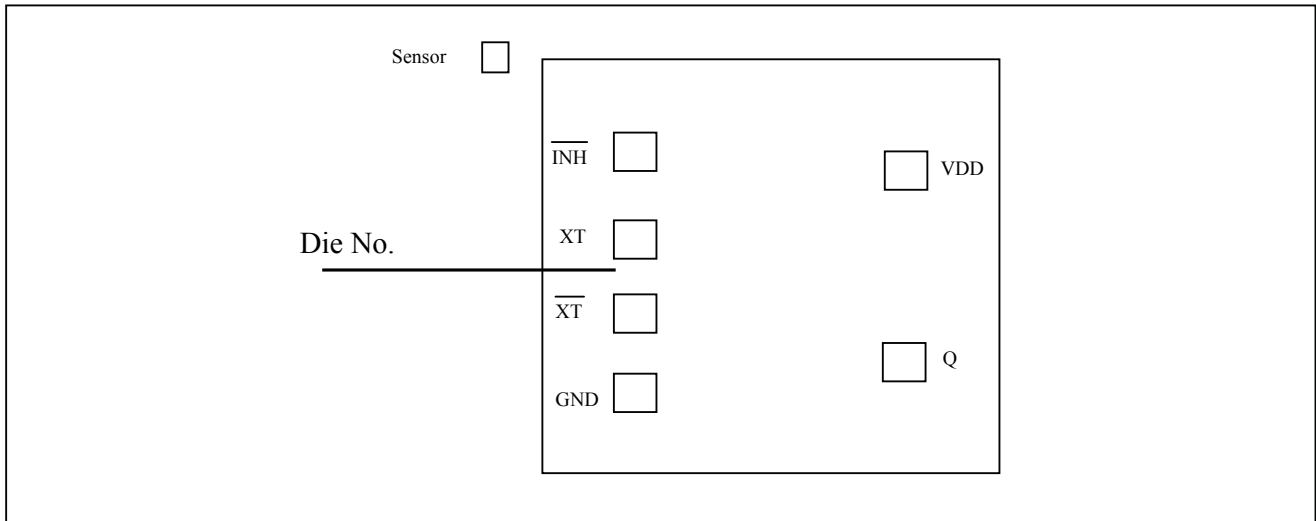

Pad Coordinate File					
Pad Name	X Coordinate	Y Coordinate	Pad Name	X Coordinate	Y Coordinate
sensor	-50	850.00	GND	184.20	112.80
$\overline{\text{INH}}$	184.20	687.10	VDD	815.20	542.00
XT	184.20	497.10	Q	815.20	159.00
$\overline{\text{XT}}$	184.20	302.80			

**Note:** Substrate is connected to GND or VDD or floating.  
**Die Size:** 950 $\mu\text{m}$ \*800 $\mu\text{m}$  (Including scribe line size.)  
**Die Thickness:** 265 $\pm$ 25 $\mu\text{m}$   
**Pad Size:** 100 $\mu\text{m}$ \*100 $\mu\text{m}$

---

**Notes**

---

***Pericom Technology Inc.***

Email: support@pti.com.cn      Web Site: www.pti.com.cn, www.pti-ic.com

**China:**      No. 20 Building, 3/F, 481 Guiping Road, Shanghai, 200233, China  
Tel: (86)-21-6485 0576      Fax: (86)-21-6485 2181

**Asia Pacific:**      Unit 1517, 15/F, Chevalier Commercial Centre, 8 Wang Hoi Rd, Kowloon Bay, Hongkong  
Tel: (852)-2243 3660      Fax: (852)- 2243 3667

**U.S.A.:**      3545 North First Street, San Jose, California 95134, USA  
Tel: (1)-408-435 0800      Fax: (1)-408-435 1100

Pericom Technology Incorporation reserves the right to make changes to its products or specifications at any time, without notice, in order to improve design or performance and to supply the best possible product. Pericom Technology does not assume any responsibility for use of any circuitry described other than the circuitry embodied in Pericom Technology product. The company makes no representations that circuitry described herein is free from patent infringement or other rights, of Pericom Technology Incorporation.

## Looking for pricing, stock, or lifecycle information?

Click below to explore more details on WIN SOURCE:

 [View PT7C5006ANDWE on WIN SOURCE](#)

 [Diodes Incorporated Information](#)

## Optimize Your Supply Chain with WIN SOURCE Solutions

-  Global Sourcing Solution
-  Obsolete Management
-  Cost Control Management
-  Shortage Management
-  Alternative Solution
-  Excess Inventory Management