

10/100/1000BASE-T GIGABIT COPPER TRANSCEIVER

FEATURES

- Fully-integrated 10BASE-T/100BASE-TX/1000BASE-T Gigabit Ethernet transceiver
- GMII, RGMII, SGMII, SerDes, RTBI and MII MAC Interface options
- Line-side copper and fiber interfaces
- On-chip low-voltage regulators
- Fully compliant with IEEE 802.3, 802.3u, and 802.3ab standards
- 0.13μ CMOS — low power and cost
- Low power
 - Less than 700 mW per port
 - Wake on LAN support
 - Advanced power management
- Trace matched output impedance
- Line-side loopback
- Low EMI emissions
- Cable plant diagnostic
 - Cable plant analyzer function detects cable plant impairments
 - Link quality indication LED
 - Automatic detection and correction of wiring pair swaps, pair skew, and pair polarity
 - Automatic MDI/MDIX crossover at all speeds
- Robust CESD tolerance
- Support for jumbo packets up to 9 KB
- IEEE 1149.1 (JTAG) boundary scan
- 128-pin MQFP, 117-pin BGA, and 100-pin FBGA packages

SUMMARY OF BENEFITS

- Simplifies system and board design.
 - Reduced I/O pin requirements with RGMII (over 50%), SGMII (over 75%), and SerDes (over 80%).
 - Clock timing can be adjusted to eliminate board trace delays required by the RGMII specification.
- Flexibility for copper or fiber applications.
- Lowers system BOM cost and simplifies system design.
- Provides interoperability with IEEE standard devices operating at 10 Mbps, 100 Mbps, and 1000 Mbps at half- and full-duplex.
- Requires no airflow or heatsink.
- Provides compliance with PCI 2.2 and PC99/PC2000.
- Eases system level debug.
- Reduces system design constraints to meet EMI emissions standards.
- Cable diagnostic function characterizes cable plant condition and immediately indicates cabling issues.
 - Prevents erroneous equipment return due to bad cable plants.
 - Prevents manufacturing fall-out due to bad cable plants.
- High CESD tolerance prevents equipment damage and return.
- Operates with larger packets for wider range of packet protocol support and improved efficiency.
- Ease of manufacturing with JTAG support, simplified power supply, and multiple MAC interfaces.

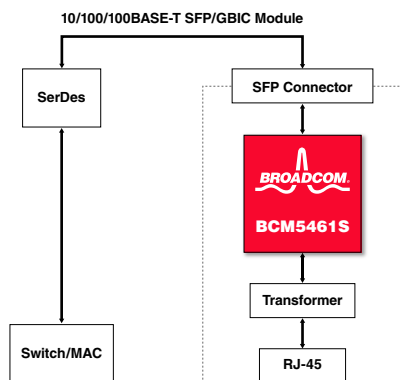

10/100/1000BASE-T SFP/GBIC Module

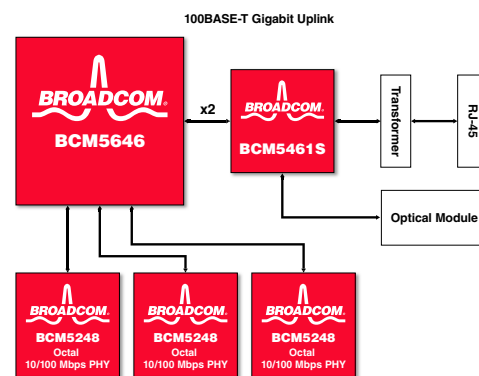

100BASE-T Gigabit Uplink

OVERVIEW

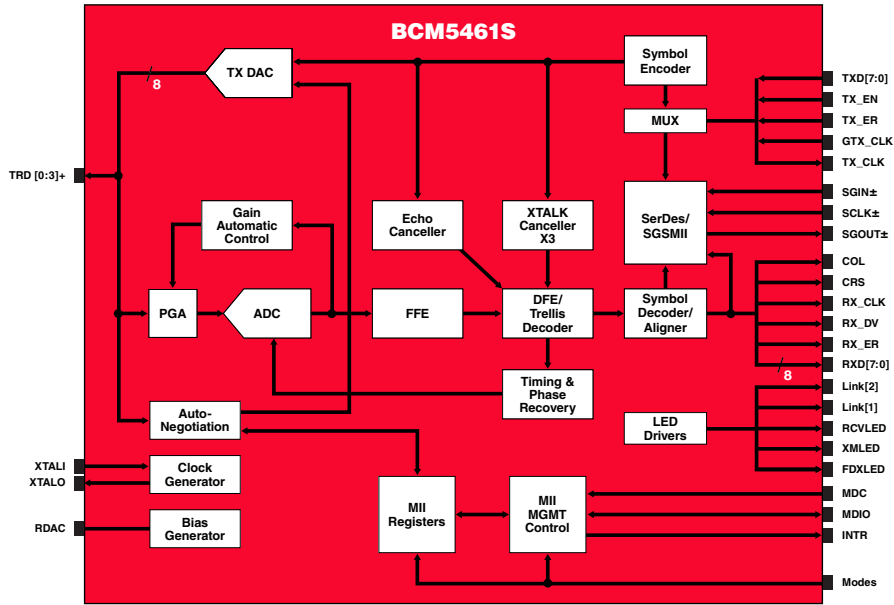

BCM5461S Reference Design

The BCM5461S is a fully integrated 10/100/1000BASE-T Gigabit Ethernet transceiver optimized for low power and small footprint size to enable backplane and uplink applications. By lowering system cost and reducing power dissipation by nearly 30%, the BCM5461S enables a new class of cost-effective Gigabit Ethernet equipment, driving the delivery of Gigabit bandwidth to the desktop.

The BCM5461S's Digital Signal Processor based architecture and advanced power management techniques combine to achieve robust and low-power operation over the existing CAT 5 twisted-pair wiring. The BCM5461S architecture also meets the requirements of 802.3, 802.3u, and 802.3ab, but maintains the industry's highest level of margin over IEEE requirements for Echo, NEXT, and FEXT. Low power is a key factor in implementing Gigabit small form factor NICs and uplinks and, at less than 700 mW per port, the BCM5461S has the industry's lowest power requirement. For NIC applications, support for Wake on LAN enables compliance with PCI 2.2 and PC99/PC2000. Also, the BCM5461S has extremely low EMI emissions, which reduces the design constraints required to meet EMI emission specifications.

The BCM5461S supports GMII, RGMII, SGMII, SerDes, TBI, RTBI, and MII MAC interfaces. A unique feature of the BCM5461S is its ability to support both copper and fiber networks, with an integrated SerDes PHY interface that can connect directly to a fiber-optic module. Switching between copper and fiber media can be accomplished either automatically or through software control. The BCM5461S monitors copper link and fiber signal detect status and, based on priorities set at initialization,

automatically swaps either copper traffic or fiber traffic to the MAC/switch.

This device is another member of Broadcom's 0.13µm Gigabit copper PHY family, joining the BCM5404, BCM5414, BCM5421, BCM5421S, BCM5424, BCM5434, BCM5464, and BCM5464S. The 0.13µm process is the optimal process that offers the best performance, lowest cost, and lowest power for Gigabit copper solutions. Further, devices based on the 0.13µm process offer an excellent long-term cost curve, enabling better cost reduction over time compared to older technologies, without having to redesign or requalify a new part.

The BCM5461S incorporates a number of advanced features. A link quality indicator LED provides instant notification of any problems with the wiring plant operating at the desired speed. This includes physical wiring defects that the BCM5461S cannot automatically correct and channel conditions such as excessive cable length, and return loss, crosstalk, echo, and noise. Broadcom's cable analyzer software can be used with the device to provide remote management of the cable and a first level of diagnostics and fault isolation.

The BCM5461S also has ESD tolerance that exceeds typical industry standards. This prevents ESD damage during manufacturing and during CESD events in the field. Cable-sourced electrostatic discharge (CESD) is an ESD event that occurs when an electrically charged network cable is plugged into a network port, an issue becoming more prevalent with contemporary cable installations.

Broadcom®, the pulse logo, Connecting everything®, and the Connecting everything logo are among the trademarks of Broadcom Corporation and/or its affiliates in the United States, certain other countries and/or the EU. Any other trademarks or trade names mentioned are the property of their respective owners.

Connecting
everything®



BROADCOM CORPORATION
16215 Alton Parkway, P.O. Box 57013
Irvine, California 92619-7013



© 2006 by BROADCOM CORPORATION. All rights reserved.

5461-PB06-R 04/17/06

Phone: 949-450-8700
Fax: 949-450-8710
E-mail: info@broadcom.com
Web: www.broadcom.com

Looking for pricing, stock, or lifecycle information?

Click below to explore more details on WIN SOURCE:

-  [View BCM5461SA1KPF on WIN SOURCE](#)
-  [Broadcom Limited Information](#)

Optimize Your Supply Chain with WIN SOURCE Solutions

-  Global Sourcing Solution
-  Obsolete Management
-  Cost Control Management
-  Shortage Management
-  Alternative Solution
-  Excess Inventory Management