



THE DATASHEET OF PS2501-4XSM





PS2501-1, PS2501-2, PS2501-4



DESCRIPTION

The PS2501-1, PS2501-2 and PS2501-4 series of optically coupled isolator consist of an infrared light emitting diode and an NPN silicon photo transistor in a space efficient Dual In Line Plastic Package.

FEATURES

- AC Isolation Voltage 5300V_{RMS}
- CTR Selections Available
- Wide Operating Temperature Range -30°C to +100°C
- Lead Free and RoHS Compliant
- UL File E91231 Package Code "EE"
- VDE Approval Certificate No. 40028086

APPLICATIONS

- Computer Terminals
- Industrial System Controllers
- Measuring Instruments
- Signal Transmission between Systems of Different Potentials and Impedances

ORDER INFORMATION

- Add X after PN for VDE Approval
- Add G after PN for 10mm lead spacing
- Add SM after PN for Surface Mount
- Add SMT&R after PN for Surface Mount Tape & Reel
(Available for PS2501-1SM and PS2501-2SM)

PS2501-1



PS2501-2

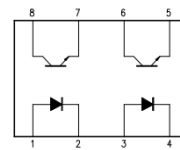

PS2501-4

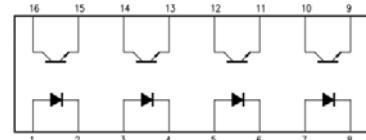

ABSOLUTE MAXIMUM RATINGS

Stresses exceeding the absolute maximum ratings can cause permanent damage to the device. Exposure to absolute maximum ratings for long periods of time can adversely affect reliability.

Input

Forward Current	50mA
Reverse Voltage	6V
Power dissipation	70mW

Output

Collector to Emitter Voltage BV _{CEO}	80V
Emitter to Collector Voltage BV _{ECO}	6V
Collector Current	50mA
Power Dissipation	150mW

Total Package

Operating Temperature	-30 to +100 °C
Storage Temperature	-55 to +125 °C
Total Power Dissipation (derate linearly 2.67mW/°C at >25°C)	200mW
Lead Soldering Temperature (10s)	260°C

ISOCOM COMPONENTS 2004 LTD

Unit 25B, Park View Road West, Park View Industrial Estate
Hartlepool, Cleveland, TS25 1PE, United Kingdom
Tel : +44 (0)1429 863 609 Fax : +44 (0)1429 863 581
e-mail : sales@isocom.co.uk
<http://www.isocom.com>

ISOCOM COMPONENTS ASIA LTD

Hong Kong Office
Block A, 8/F, Wah Hing Industrial Mansion
36 Tai Yau Street, San Po Kong, Kowloon, Hong Kong
Tel : +852 2995 9217 Fax : +852 8161 6292
e-mail : sales@isocom.com.hk

PS2501-1, PS2501-2, PS2501-4

ELECTRICAL CHARACTERISTICS (Ambient Temperature = 25°C unless otherwise specified)

INPUT

Parameter	Symbol	Test Condition	Min	Typ.	Max	Unit
Forward Voltage	V_F	$I_F = 20\text{mA}$		1.2	1.4	V
Reverse Voltage	V_R	$I_R = 10\mu\text{A}$	6.0			V
Reverse Leakage	I_R	$V_R = 4\text{V}$			10	μA
Terminal Capacitance	C_t	$V = 0\text{V}, f = 1\text{KHz}$		30	250	pF

OUTPUT

Parameter	Symbol	Test Condition	Min	Typ.	Max	Unit
Collector—Emitter Breakdown Voltage	BV_{CEO}	$I_C = 1\text{mA}, I_F = 0\text{mA}$	80			V
Emitter—Collector Breakdown Voltage	BV_{ECO}	$I_E = 100\mu\text{A}, I_F = 0\text{mA}$	6			V
Collector-Emitter Dark Current	I_{CEO}	$V_{CE} = 20\text{V}, I_F = 0\text{mA}$			100	nA

COUPLED

Parameter	Symbol	Test Condition	Min	Typ.	Max	Unit
Current transfer ratio	CTR	$I_F = 5\text{mA}, V_{CE} = 5\text{V}$	80		600	%
		Optional CTR Grades				
		GR L (PS2501-1 only)	100 200		300 400	
Collector—Emitter Saturation Voltage	$V_{CE(sat)}$	$I_F = 10\text{mA}, I_C = 2\text{mA}$			0.3	V
Input to Output Isolation Voltage	V_{ISO}	AC 1 minute, RH = 40 to 60% Note 1	5300			V_{RMS}
Input to Output Isolation Resistance	R_{ISO}	$V_{IO} = 500\text{V}$ Note 1	5×10^{10}			Ω
Output Rise Time	t_r	$V_{CE} = 2\text{V}, I_C = 2\text{mA}, R_L = 100\Omega$		4	18	μs
Output Fall Time	t_f	$V_{CE} = 2\text{V}, I_C = 2\text{mA}, R_L = 100\Omega$		3	18	μs

Note 1 : Measure with input leads shorted together and output leads shorted together.



PS2501-1, PS2501-2, PS2501-4

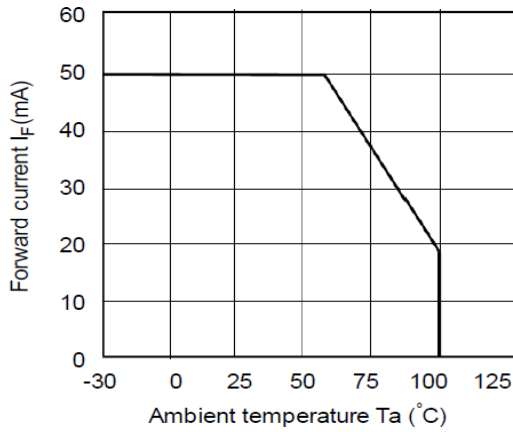

Fig 1 Forward Current vs T_A

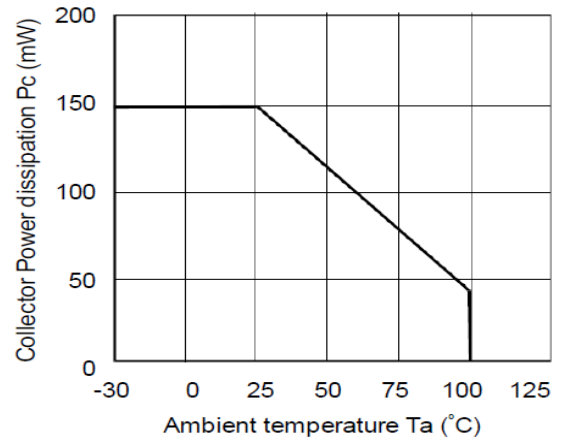

Fig 2 Collector Power Dissipation vs T_A

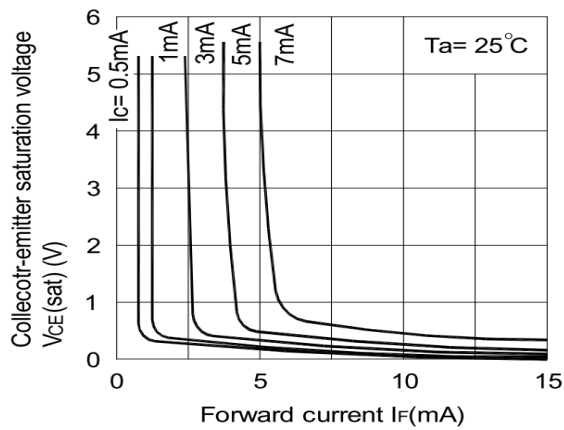

Fig 3 Collector-emitter Saturation Voltage vs Forward Current

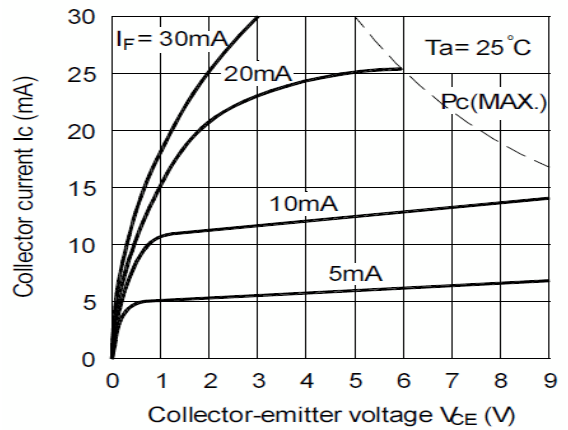

Fig 4 Collector Current vs Collector-emitter Voltage

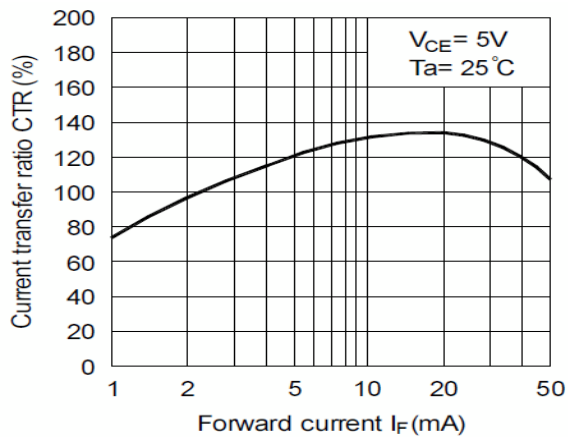

Fig 5 Current Transfer Ratio vs Forward Current

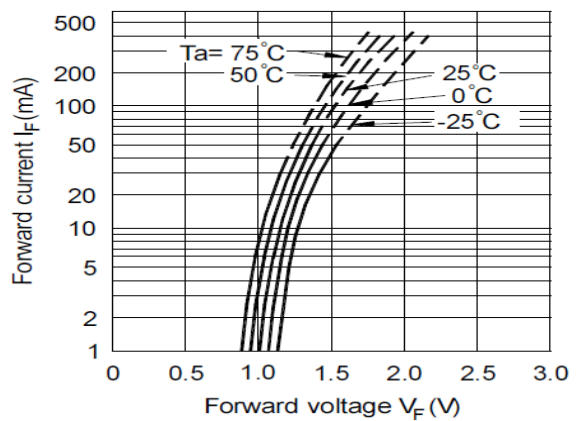

Fig 6 Forward Current vs Forward Voltage



PS2501-1, PS2501-2, PS2501-4

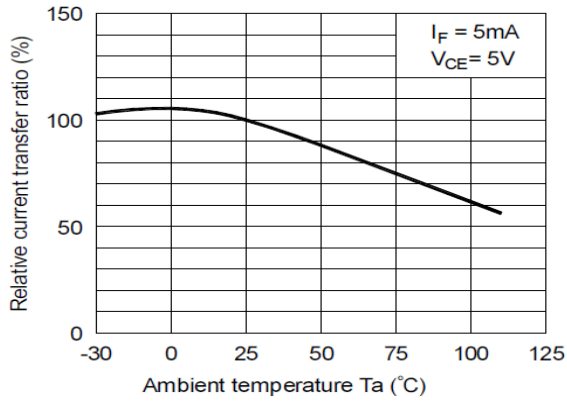

Fig 7 Relative CTR vs T_A

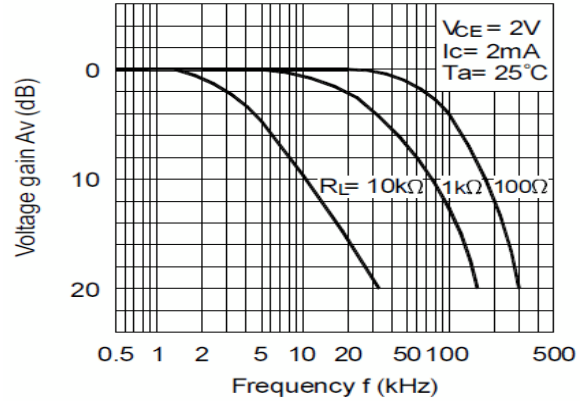

Fig 8 Frequency Response

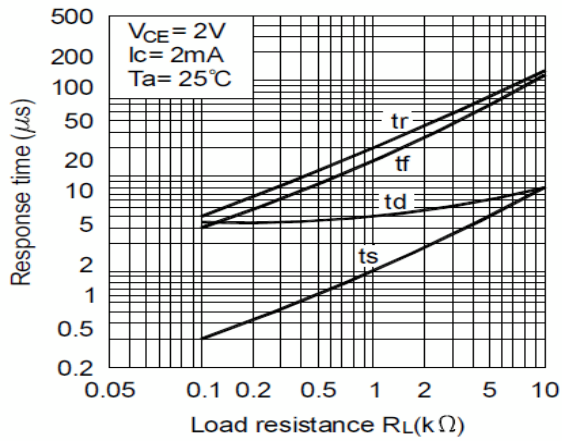
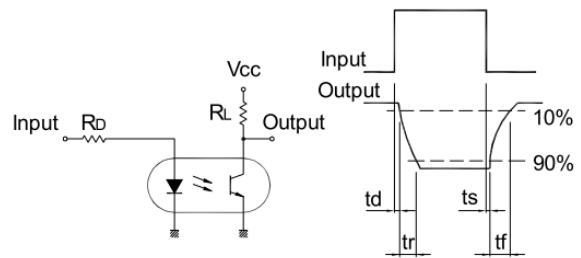

Fig 9 Response Time vs Load Resistance



Response Time Test Circuit



PS2501-1, PS2501-2, PS2501-4

ORDER INFORMATION

PS2501-1 (UL Approval)			
After PN	PN	Description	Packing quantity
None	PS2501-1, PS2501-1GR, PS2501-1L	Standard DIP4	100 pcs per tube
G	PS2501-1G, PS2501-1GRG, PS2501-1LG	10mm Lead Spacing	100 pcs per tube
SM	PS2501-1SM, PS2501-1GRSM, PS2501-1LSM	Surface Mount	100 pcs per tube
SMT&R	PS2501-1SMT&R, PS2501-1GRSMT&R, PS2501-1LSMT&R	Surface Mount Tape & Reel	1000 pcs per reel

PS2501-2 (UL Approval)			
After PN	PN	Description	Packing quantity
None	PS2501-2, PS2501-2GR	Standard DIP8	50 pcs per tube
G	PS2501-2G, PS2501-2GRG	10mm Lead Spacing	50 pcs per tube
SM	PS2501-2SM, PS2501-2GRSM	Surface Mount	50 pcs per tube
SMT&R	PS2501-2SMT&R, PS2501-2GRSMT&R,	Surface Mount Tape & Reel	1000 pcs per reel

PS2501-4 (UL Approval)			
After PN	PN	Description	Packing quantity
None	PS2501-4, PS2501-4GR	Standard DIP16	25 pcs per tube
G	PS2501-4G, PS2501-4GRG	10mm Lead Spacing	25 pcs per tube
SM	PS2501-4SM, PS2501-4GRSM	Surface Mount	25 pcs per tube

CTR grade "L" available only for PS2501-1.



PS2501-1, PS2501-2, PS2501-4

ORDER INFORMATION

PS2501-1X (UL and VDE Approvals)			
After PN	PN	Description	Packing quantity
None	PS2501-1X, PS2501-1XGR, PS2501-1XL	Standard DIP4	100 pcs per tube
G	PS2501-1XG, PS2501-1XGRG, PS2501-1XLG	10mm Lead Spacing	100 pcs per tube
SM	PS2501-1XSM, PS2501-1XGRSM, PS2501-1XLSM	Surface Mount	100 pcs per tube
SMT&R	PS2501-1XSMT&R, PS2501-1XGRSMT&R, PS2501-1XLSMT&R	Surface Mount Tape & Reel	1000 pcs per reel

PS2501-2X (UL and VDE Approvals)			
After PN	PN	Description	Packing quantity
None	PS2501-2X, PS2501-2XGR	Standard DIP8	50 pcs per tube
G	PS2501-2XG, PS2501-2XGRG	10mm Lead Spacing	50 pcs per tube
SM	PS2501-2XSM, PS2501-2XGRSM,	Surface Mount	50 pcs per tube
SMT&R	PS2501-2XSMT&R, PS2501-2XGRSMT&R	Surface Mount Tape & Reel	1000 pcs per reel

PS2501-4X (UL and VDE Approvals)			
After PN	PN	Description	Packing quantity
None	PS2501-4X, PS2501-4XGR,	Standard DIP16	25 pcs per tube
G	PS2501-4XG, PS2501-4XGRG	10mm Lead Spacing	25 pcs per tube
SM	PS2501-4XSM, PS2501-4XGRSM	Surface Mount	25 pcs per tube

CTR grade "L" available only for PS2501-1.



PS2501-1, PS2501-2, PS2501-4

PACKAGE DIMENSIONS in mm (inch)

DIP

PS2501-1

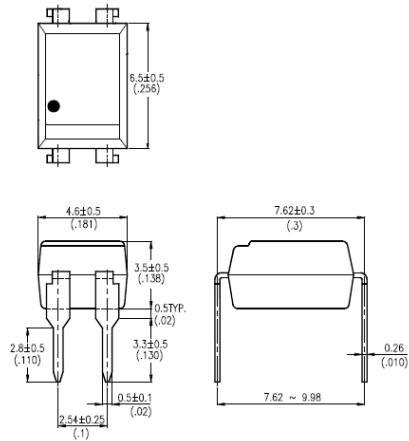

PS2501-2

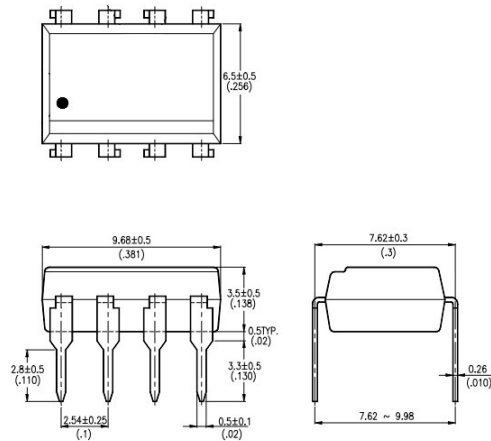

PS2501-4

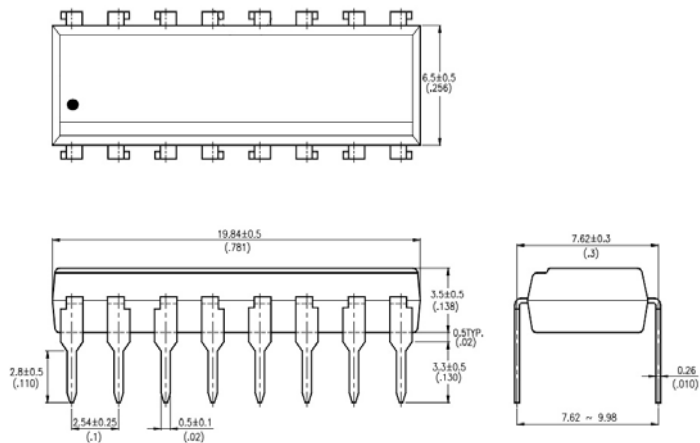



PS2501-1, PS2501-2, PS2501-4

PACKAGE DIMENSIONS in mm (inch)

G Form

PS2501-1G

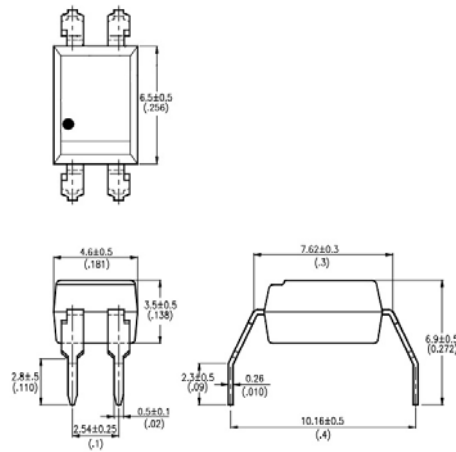

PS2501-2G

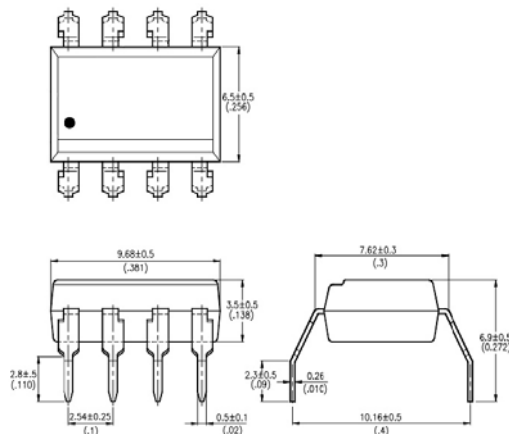

PS2501-4G

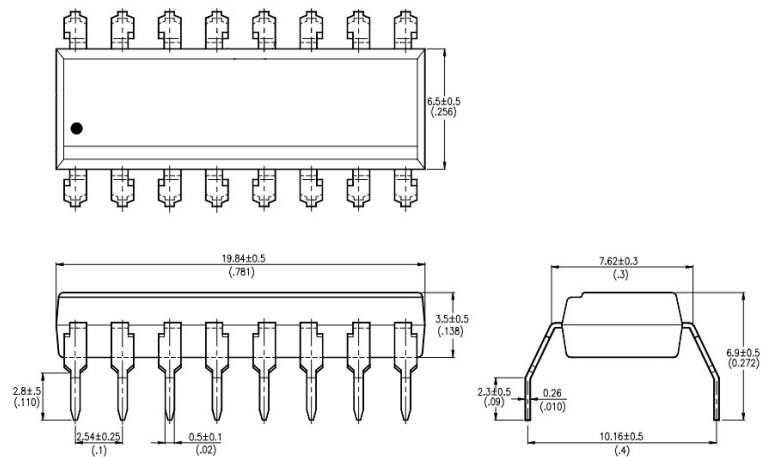



PS2501-1, PS2501-2, PS2501-4

PACKAGE DIMENSIONS in mm (inch)

SMD

PS2501-1SM

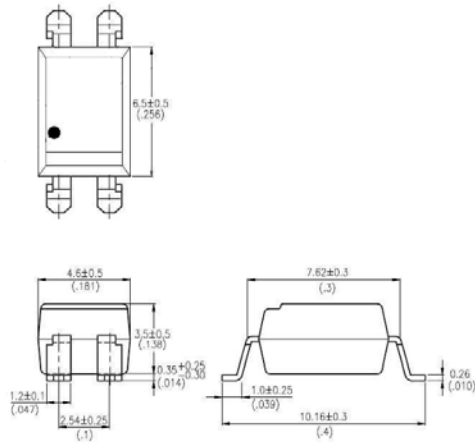

PS2501-2SM

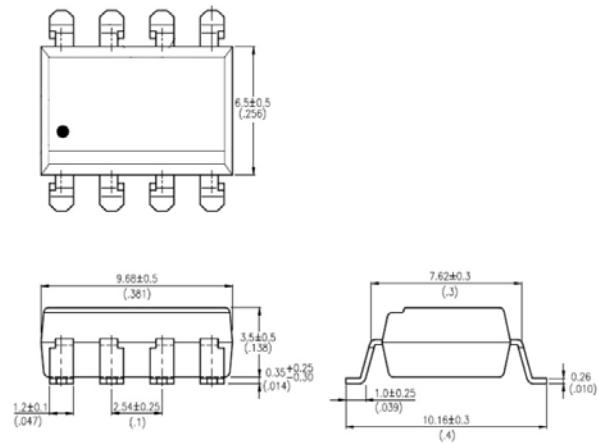

PS2501-4SM

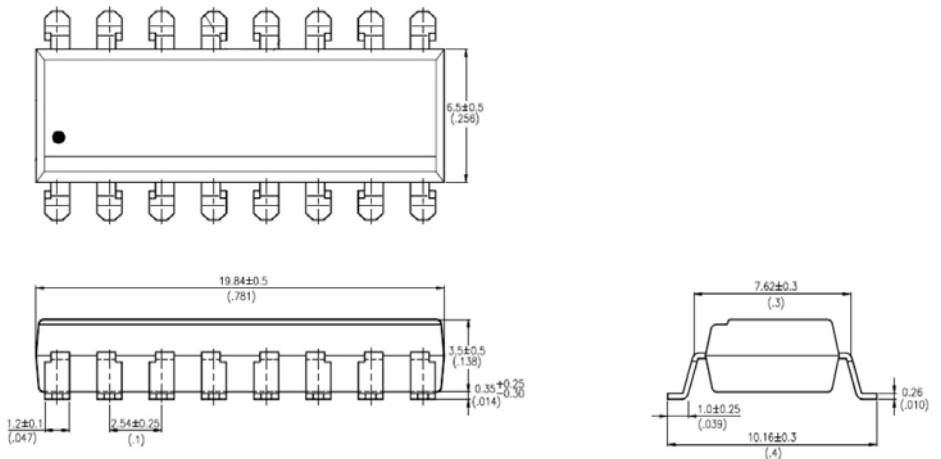



PS2501-1, PS2501-2, PS2501-4

RECOMMENDED PAD LAYOUT FOR SMD (mm)

PS2501-1SM

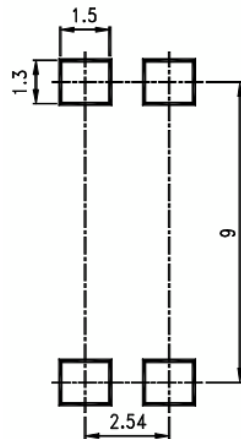

PS2501-2SM

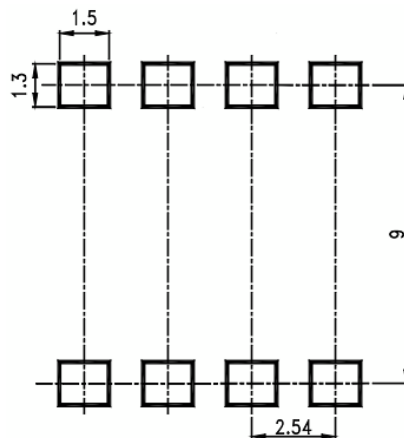

PS2501-4SM

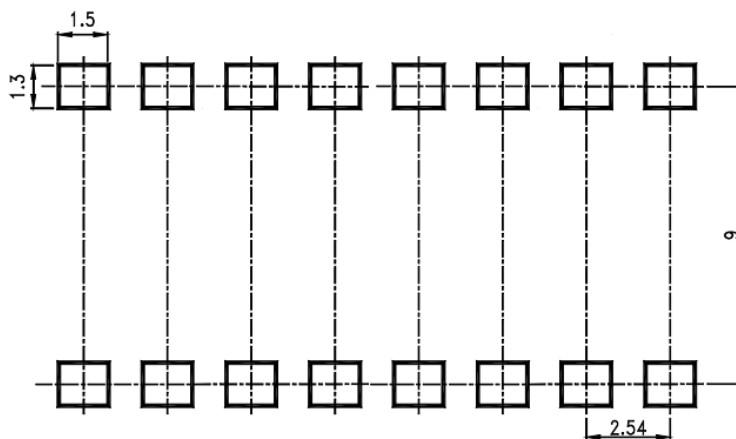



PS2501-1, PS2501-2, PS2501-4

TAPE AND REEL PACKAGING

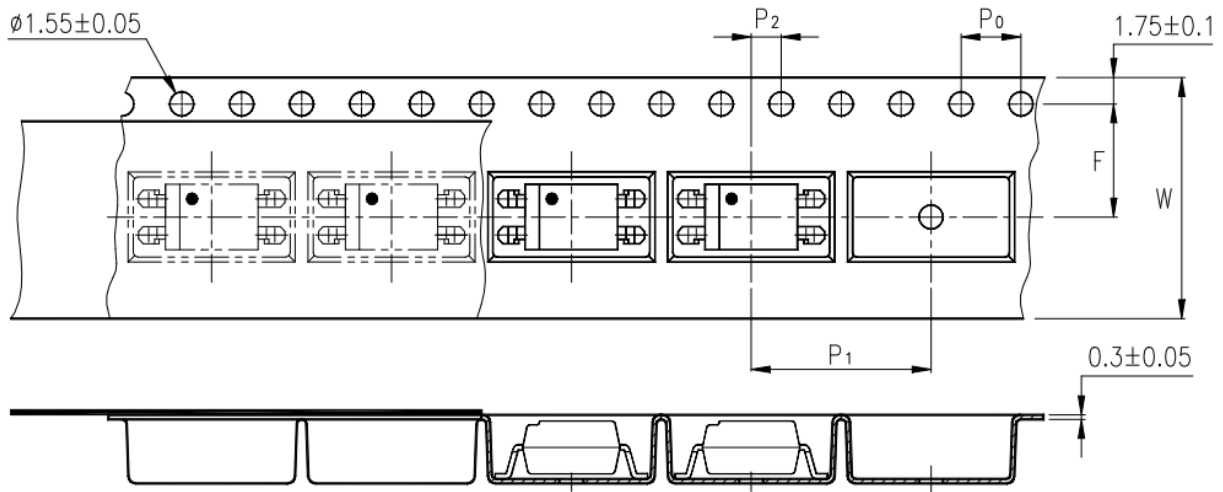

PS2501-1SMT&R

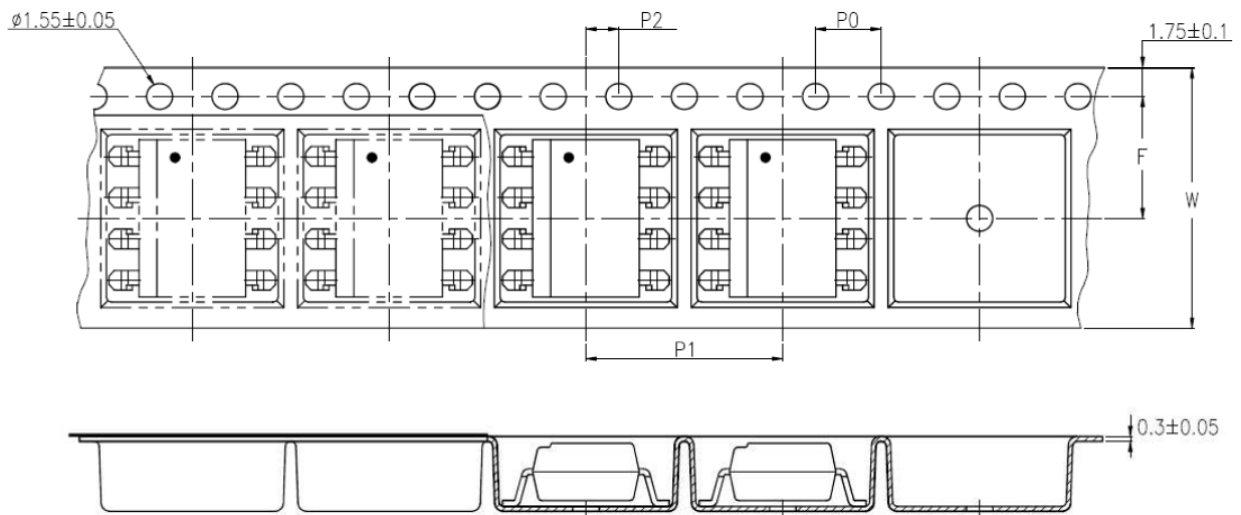

PS2501-2SMT&R

Description	Symbol	Dimensions in mm (inches)
Tape wide	W	16 ± 0.3 (.63)
Pitch of sprocket holes	P_0	4 ± 0.1 (.15)
Distance of compartment	F	7.5 ± 0.1 (.295)
Distance of compartment to compartment	P_2	2 ± 0.1 (.079)
Distance of compartment to compartment	P_1	12 ± 0.1 (.472)



PS2501-1, PS2501-2, PS2501-4

**IR REFLOW SOLDERING TEMPERATURE PROFILE FOR SMD
(One Time Reflow Soldering is Recommended)**

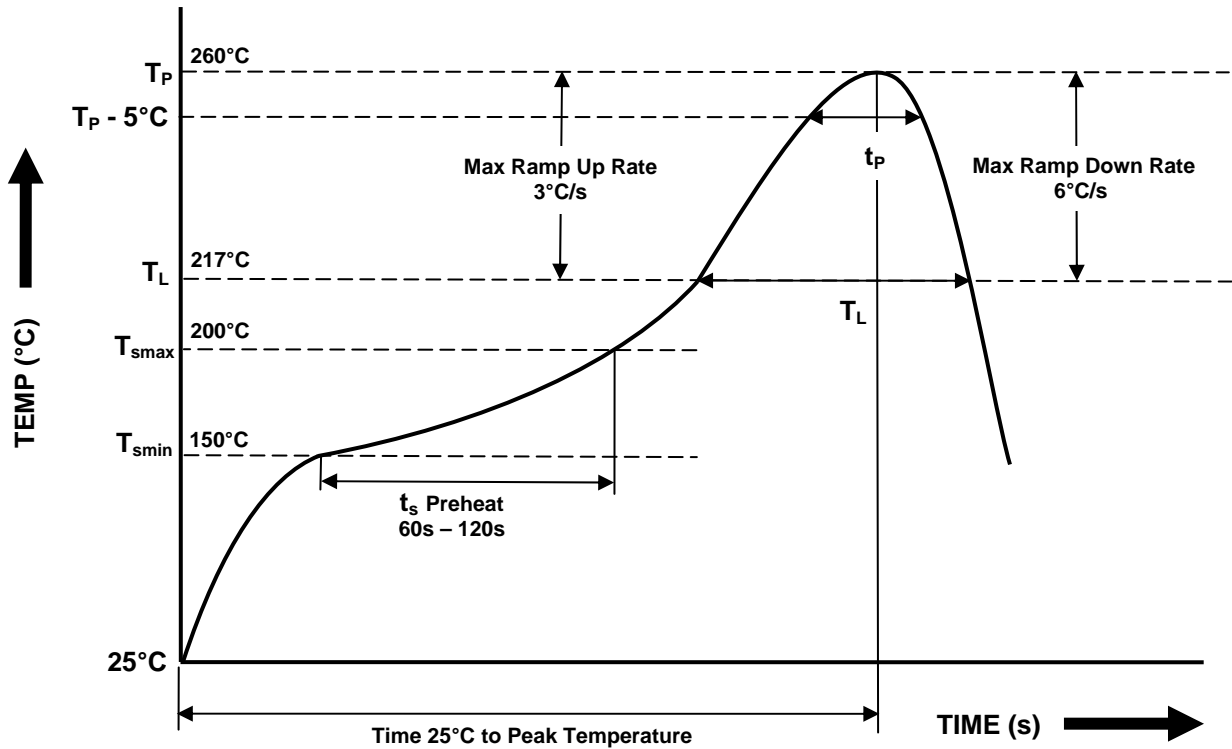

Profile Details	Conditions
Preheat - Min Temperature (T_{SMIN}) - Max Temperature (T_{SMAX}) - Time T_{SMIN} to T_{SMAX} (t_s)	150°C 200°C 60s - 120s
Soldering Zone - Peak Temperature (T_P) - Time at Peak Temperature - Liquidous Temperature (T_L) - Time within 5°C of Actual Peak Temperature ($T_P - 5^\circ C$) - Time maintained above T_L (t_L) - Ramp Up Rate (T_L to T_P) - Ramp Down Rate (T_P to T_L)	260°C 10s max 217°C 30s max 60s - 100s 3°C/s max 6°C/s max
Average Ramp Up Rate (T_{smax} to T_P)	3°C/s max
Time 25°C to Peak Temperature	8 minutes max



ISOCOM
COMPONENTS

PS2501-1, PS2501-2, PS2501-4

NOTES :

- Isocom is continually improving the quality, reliability, function or design and Isocom reserves the right to make changes without further notices.
- The products shown in this publication are designed for the general use in electronic applications such as office automation equipment, communications devices, audio/visual equipment, electrical application and instrumentation.
- For equipment/application where high reliability or safety is required, such as space applications, nuclear power control equipment, medical equipment, etc., please contact our sales representatives.
- When requiring a device for any "specific" application, please contact our sales for advice.
- The contents described herein are subject to change without prior notice.
- Do not immerse device body in solder paste.



DISCLAIMER

__ ISOCOM is continually working to improve the quality and reliability of its products. Nevertheless, semiconductor devices in general can malfunction or fail due to their inherent electrical sensitivity and vulnerability to physical stress. It is the responsibility of the buyer, when utilizing ISOCOM products, to comply with the standards of safety in making a safe design for the entire system, and to avoid situations in which a malfunction or failure of such ISOCOM products could cause loss of human life, bodily injury or damage to property.

In developing your designs, please ensure that ISOCOM products are used within specified operating ranges as set forth in the most recent ISOCOM products specifications.

__ The ISOCOM products listed in this document are intended for usage in general electronics applications (computer, personal equipment, office equipment, measuring equipment, industrial robotics, domestic appliances, etc.). These ISOCOM products are neither intended nor warranted for usage in equipment that requires extraordinarily high quality and/or reliability or a malfunction or failure of which may cause loss of human life or bodily injury ("Unintended Usage"). Unintended Usage include atomic energy control instruments, airplane or spaceship instruments, transportation Instruments, traffic signal instruments, combustion control instruments, medical Instruments, all types of safety devices, etc.. Unintended Usage of ISOCOM products listed in this document shall be made at the customer's own risk.

__ Gallium arsenide (GaAs) is a substance used in the products described in this document. GaAs dust and fumes are toxic. Do not break, cut or pulverize the product, or use chemicals to dissolve them. When disposing of the products, follow the appropriate regulations. Do not dispose of the products with other industrial waste or with domestic garbage.

__ The products described in this document are subject to the foreign exchange and foreign trade laws.

__ The information contained herein is presented only as a guide for the applications of our products. No responsibility is assumed by ISOCOM Components for any infringements of intellectual property or other rights of the third parties which may result from its use. No license is granted by implication or otherwise under any intellectual property or other rights of ISOCOM Components or others.

__ The information contained herein is subject to change without notice.

Looking for pricing, stock, or lifecycle information?

Click below to explore more details on WIN SOURCE:

- [View PS2501-4XSM on WIN SOURCE](#)
- [Isocom Components 2004 LTD Information](#)

Optimize Your Supply Chain with WIN SOURCE Solutions

- ✓ Global Sourcing Solution
- ✓ Obsolete Management
- ✓ Cost Control Management
- ✓ Shortage Management
- ✓ Alternative Solution
- ✓ Excess Inventory Management