



**THE DATASHEET OF
PKM4304PI**



PKM 4304 Series DC-DC Converters
 Input 40-75 V, Output up to 33 A / 396 W

EN/LZT 146 440 R2A November 2017
 © Flex

Key Features

- Industry standard Quarter-brick
 57.9 x 36.8 x 11.6 mm (2.28 x 1.45 x 0.46 in.)
- High efficiency, typ. 96.6% at 12 Vout, half load
- 1500 Vdc input to output isolation
- Meets safety requirements according to IEC/EN/UL 60950-1
- MTBF 3.2 Mh



General Characteristics

- Fully regulated
- Input under voltage protection
- Over temperature protection
- Output over voltage protection
- Output short-circuit protection
- Remote control
- Optional baseplate
- Optional case to ground pin (only with baseplate)
- Highly automated manufacturing ensures quality
- ISO 9001/14001 certified supplier

Safety Approvals



Design for Environment



Meets requirements in high-temperature lead-free soldering processes.

Contents

Ordering Information	2
General Information	2
Safety Specification	3
Absolute Maximum Ratings	4
Electrical Specification	
12V, 33A / 396W	PKM4304 PI 5
EMC Specification	9
Operating Information	10
Thermal Consideration	11
Connections	12
Mechanical Information	13
Soldering Information	15
Delivery Information	16
Product Qualification Specification	17

Technical Specification

PKM 4304 Series DC-DC Converters
Input 40-75 V, Output up to 33 A / 396 W

EN/LZT 146 440 R2A

November 2017

© Flex

Ordering Information

Product program	Output
PKM 4304 PI	12 V, 33 A / 396 W

Product number and Packaging

PKM 4304 PI n ₁ n ₂ n ₃ n ₄				
Options	n ₁	n ₂	n ₃	n ₄
Remote control logic	o			
Baseplate		o		
Case to ground pin			o	
Pin length				o

Options	Description
n ₁	Negative * P Positive
n ₂	Open frame * HS Baseplate
n ₃	G Case to ground pin
n ₄	5.30 mm * LA 3.69 mm LB 4.57 mm LC 2.79 mm

Note: (1) Case to ground pin only available with baseplate

Note: (2) If several options needed below sequence is to be used
LOGIC OPTION → BASEPLATE → CASE GROUND → PIN LENGTH

Example: PKM4304 PIPHSGLA

* Standard variant (i.e. no option selected).

General Information**Reliability**

The failure rate (λ) and mean time between failures (MTBF = $1/\lambda$) is calculated at max output power and an operating ambient temperature (T_A) of +40°C. Flex Power Modules uses Telcordia SR-332 Issue 2 Method 1 to calculate the mean steady-state failure rate and standard deviation (σ).

Telcordia SR-332 Issue 2 also provides techniques to estimate the upper confidence levels of failure rates based on the mean and standard deviation.

Mean steady-state failure rate, λ	Std. deviation, σ
317 nFailures/h	39.8 nFailures/h

MTBF (mean value) for the PKM 4000 series = 3.2 Mh.
MTBF at 90% confidence level = 2.7 Mh

Compatibility with RoHS requirements

The products are compatible with the relevant clauses and requirements of the RoHS directive 2011/65/EU and have a maximum concentration value of 0.1% by weight in homogeneous materials for lead, mercury, hexavalent chromium, PBB and PBDE and of 0.01% by weight in homogeneous materials for cadmium.

Exemptions in the RoHS directive utilized in Flex Power Modules products are found in the Statement of Compliance document.

Flex Power Modules fulfills and will continuously fulfill all its obligations under regulation (EC) No 1907/2006 concerning the registration, evaluation, authorization and restriction of chemicals (REACH) as they enter into force and is through product materials declarations preparing for the obligations to communicate information on substances in the products.

Quality Statement

The products are designed and manufactured in an industrial environment where quality systems and methods like ISO 9000, Six Sigma, and SPC are intensively in use to boost the continuous improvements strategy. Infant mortality or early failures in the products are screened out and they are subjected to an ATE-based final test. Conservative design rules, design reviews and product qualifications, plus the high competence of an engaged work force, contribute to the high quality of the products.

Warranty

Warranty period and conditions are defined in Flex Power Modules General Terms and Conditions of Sale.

Limitation of Liability

Flex Power Modules does not make any other warranties, expressed or implied including any warranty of merchantability or fitness for a particular purpose (including, but not limited to, use in life support applications, where malfunctions of product can cause injury to a person's health or life).

© Flex 2017

The information and specifications in this technical specification is believed to be correct at the time of publication. However, no liability is accepted for inaccuracies, printing errors or for any consequences thereof. Flex reserves the right to change the contents of this technical specification at any time without prior notice.

Technical Specification

PKM 4304 Series DC-DC Converters
Input 40-75 V, Output up to 33 A / 396 W

EN/LZT 146 440 R2A November 2017

© Flex

Safety Specification

General information

Flex Power Modules DC/DC converters and DC/DC regulators are designed in accordance with the safety standards IEC 60950-1, EN 60950-1 and UL 60950-1 *Safety of Information Technology Equipment*.

IEC/EN/UL 60950-1 contains requirements to prevent injury or damage due to the following hazards:

- Electrical shock
- Energy hazards
- Fire
- Mechanical and heat hazards
- Radiation hazards
- Chemical hazards

On-board DC/DC converters, Power interface modules and DC/DC regulators are defined as component power supplies. As components they cannot fully comply with the provisions of any safety requirements without "conditions of acceptability". Clearance between conductors and between conductive parts of the component power supply and conductors on the board in the final product must meet the applicable safety requirements. Certain conditions of acceptability apply for component power supplies with limited stand-off (see Mechanical Information and Safety Certificate for further information). It is the responsibility of the installer to ensure that the final product housing these components complies with the requirements of all applicable safety standards and regulations for the final product.

Component power supplies for general use should comply with the requirements in IEC/EN/UL 60950/1 *Safety of Information Technology Equipment*. Product related standards, e.g. IEEE 802.3af *Power over Ethernet*, and ETS-300132-2 *Power interface at the input to telecom equipment, operated by direct current (dc)* are based on IEC/EN/UL 60950-1 with regards to safety.

Flex Power Modules DC/DC converters, Power interface modules and DC/DC regulators are UL 60950-1 recognized and certified in accordance with EN 60950-1. The flammability rating for all construction parts of the products meet requirements for V-0 class material according to IEC 60695-11-10, *Fire hazard testing, test flames – 50 W* horizontal and vertical flame test methods.

Isolated DC/DC converters

The product may provide basic or functional insulation between input and output according to IEC/EN/UL 60950-1 (see Safety Certificate), different conditions shall be met if the output of a basic or a functional insulated product shall be considered as safety extra low voltage (SELV).

For basic insulated products (see Safety Certificate) the output is considered as safety extra low voltage (SELV) if one of the following conditions is met:

- The input source provides supplementary or double or reinforced insulation from the AC mains according to IEC/EN/UL 60950-1.
- The input source provides functional or basic insulation from the AC mains and the product's output is reliably connected to protective earth according to IEC/EN/UL 60950-1.

For functional insulated products (see Safety Certificate) the output is considered as safety extra low voltage (SELV) if one of the following conditions is met:

- The input source provides double or reinforced insulation from the AC mains according to IEC/EN/UL 60950-1.
- The input source provides basic or supplementary insulation from the AC mains and the product's output is reliably connected to protective earth according to IEC/EN/UL 60950-1.
- The input source is reliably connected to protective earth and provides basic or supplementary insulation according to IEC/EN/UL 60950-1 and the maximum input source voltage is 60 Vdc.

Galvanic isolation between input and output is verified in an electric strength test and the isolation voltage (V_{iso}) meets the voltage strength requirement for basic insulation according to IEC/EN/UL 60950-1.

It is recommended to use a slow blow fuse at the input of each product. If an input filter is used in the circuit the fuse should be placed in front of the input filter. In the rare event of a component problem that imposes a short circuit on the input source, this fuse will provide the following functions:

- Isolate the fault from the input power source so as not to affect the operation of other parts of the system
- Protect the distribution wiring from excessive current and power loss thus preventing hazardous overheating

Technical Specification

PKM 4304 Series DC-DC Converters
 Input 40-75 V, Output up to 33 A / 396 W

EN/LZT 146 440 R2A November 2017
 © Flex

Absolute Maximum Ratings

Characteristics		min	typ	max	Unit
T_{P1}	Operating Temperature (see Thermal Consideration section)	-40		+90	°C
T_S	Storage temperature	-55		+125	°C
V_I	Input voltage	-0.5		+80	V
V_{iso}	Isolation voltage (input to output test voltage)			1500	Vdc
V_{tr}	Input voltage transient (t_p 100 ms)			100	V
V_{RC}	Remote Control pin voltage (see Operating Information section)	Positive logic option		15	V
		Negative logic option	-0.5	15	

Stress in excess of Absolute Maximum Ratings may cause permanent damage. Absolute Maximum Ratings, sometimes referred to as no destruction limits, are normally tested with one parameter at a time exceeding the limits of Output data or Electrical Characteristics. If exposed to stress above these limits, function and performance may degrade in an unspecified manner.

Fundamental Circuit Diagram

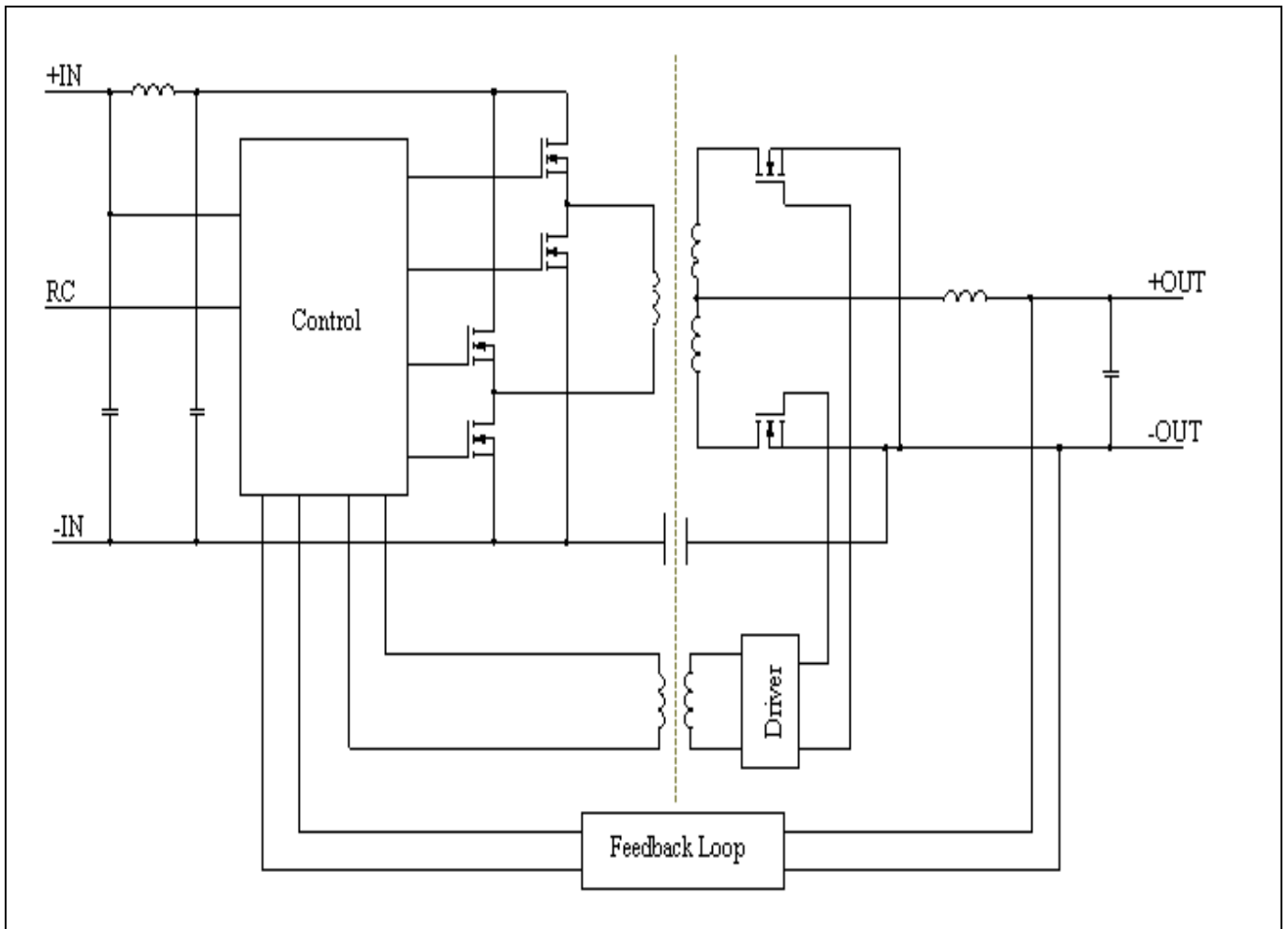

Technical Specification

PKM 4304 Series DC-DC Converters
 Input 40-75 V, Output up to 33 A / 396 W

EN/LZT 146 440 R2A

November 2017

© Flex

12 V/33 A Electrical Specification
PKM 4304 PI
 $T_{P1} = -40$ to $+90^{\circ}\text{C}$, $V_I = 40$ to 75 V, $I_O = 0$ to 33 A.. unless otherwise specified under Conditions.

 Typical values given at: $T_{P1} = +25^{\circ}\text{C}$, $V_I = 53$ V, max P_O , unless otherwise specified under Conditions.

 Additional $C_{in} = 100$ μF , $C_{out} = 100$ μF . See Operating Information section for selection of capacitor types.

Characteristics		Conditions	min	typ	max	Unit
V_I	Input voltage range		40	53	75	V
V_{loff}	Turn-off input voltage	Decreasing input voltage	32	33.1	34	V
V_{lon}	Turn-on input voltage	Increasing input voltage	34	35.4	36	V
C_I	Internal input capacitance			17.6		μF
I_{RC}	RC pin sink current	min I_O , negative logic	0.5			mA
V_{RC}	RC open circuit voltage			5.26		V
V_{RC-th}	RC transition threshold	min I_O , negative logic		2.60		V
P_O	Output power	$V_I = 75$ V	0		396	W
		$V_I = 53$ V	0		396	W
		$V_I = 40$ V	0		396	W
η	Efficiency	50 % of max I_O		96.6		%
		max I_O		95.5		
		50 % of max I_O , $V_I = 40$ V		96.7		
		max I_O , $V_I = 40$ V		95.2		
P_d	Power Dissipation	max I_O		18		W
P_{ii}	Input idling power	$I_O = 0$ A, $V_I = 53$ V		3.1		W
P_{RC}	Input standby power	$V_I = 53$ V (turned off with RC)		0.13		W
f_s	Switching frequency		100	125	150	kHz

V_{oi}	Output voltage initial setting and accuracy	$T_{P1} = +25^{\circ}\text{C}$, $V_I = 53$ V, $I_O = 0$ A	11.88	12.00	12.12	V
V_O	Output voltage tolerance band	0 to 100 % of max I_O	11.64		12.36	V
	Idling voltage	$I_O = 0$ A	11.70	12.00	12.30	V
	Line regulation	max I_O , from min V_I to max V_I		0.14	0.28	V
	Load regulation	$V_I = 53$ V, from min I_O to max I_O		0.06	0.18	V
V_{tr}	Load transient voltage deviation	$V_I = 53$ V, Load step 25-75-25 % of max I_O , $di/dt = 5$ A/ μs		± 0.3	± 0.5	V
t_{tr}	Load transient recovery time	see Note 1		0.1		ms
t_r	Ramp-up time (from 10-90 % of V_{oi})	max I_O	3	7	15	ms
t_s	Start-up time (from V_I connection to 90 % of V_{oi})		14	25	ms	
t_f	V_I shut-down fall time (from V_I off to 10 % of V_O)	max I_O		0.2		ms
		$I_O = 0$ A		2.4		s
t_{RC}	RC start-up time	max I_O		10		ms
	RC shut-down fall time (from RC off to 10 % of V_O)	max I_O		0.6		ms
		$I_O = 0$ A		2.4		s
I_O	Output current		0		33	A
I_{lim}	Current limit threshold	$T_{P1} < \text{max } T_{P1}$		41		A
I_{sc}	Short circuit current	$T_{P1} = 25^{\circ}\text{C}$, see Note 2		47		A
V_{Oac}	Output ripple & noise	See ripple & noise section, max I_O		170	250	mVp-p

 Note 1: Output capacitor 3300 μF

Note 2: See Operating Information section

Technical Specification

PKM 4304 Series DC-DC Converters
 Input 40-75 V, Output up to 33 A / 396 W

EN/LZT 146 440 R2A November 2017
 © Flex

12 V/33 A Typical Characteristics

PKM 4304 PI

Efficiency

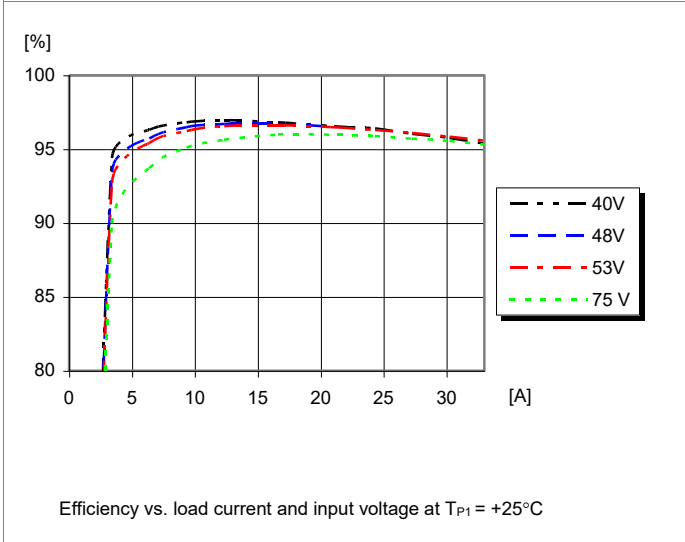

Power Dissipation

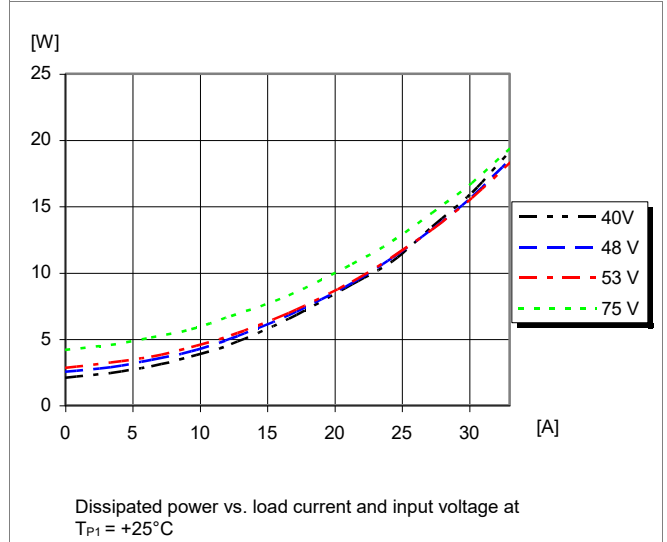

Output Characteristics

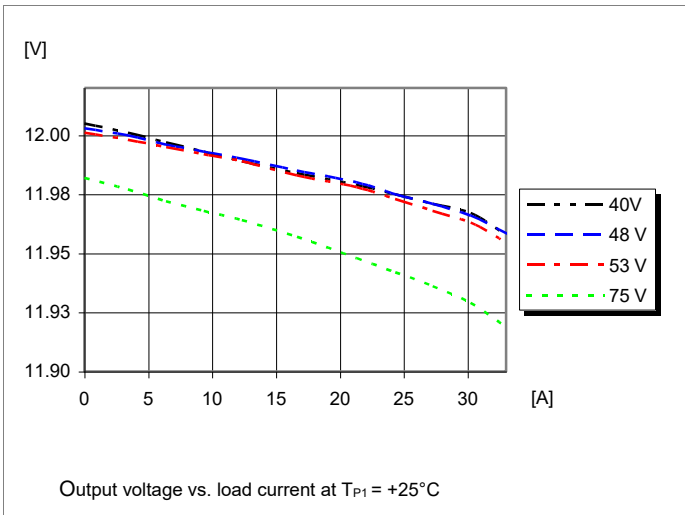

Current Limit Characteristics

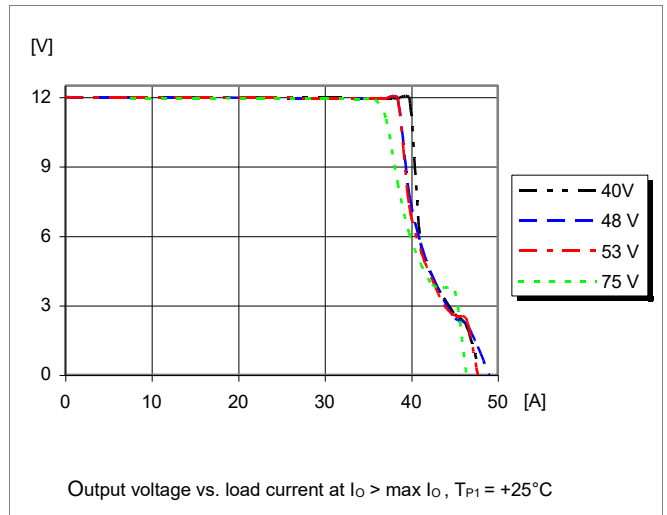

Technical Specification

PKM 4304 Series DC-DC Converters
 Input 40-75 V, Output up to 33 A / 396 W

EN/LZT 146 440 R2A November 2017
 © Flex

12 V/33 A Typical Characteristics

PKM 4304 PI

Output Current Derating, open frame

Thermal Resistance, open frame

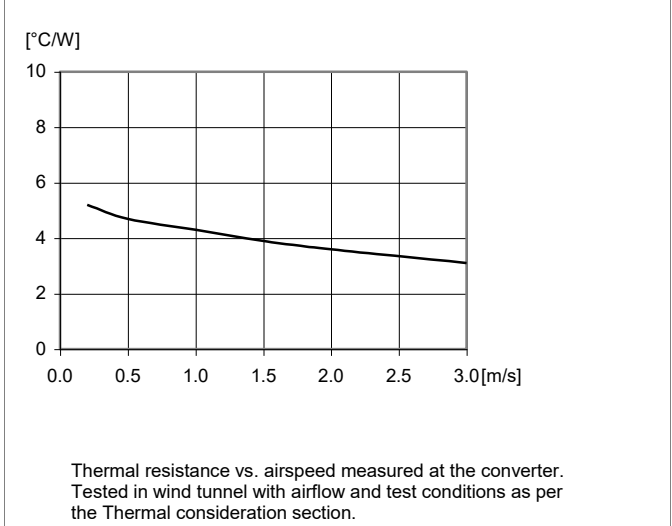
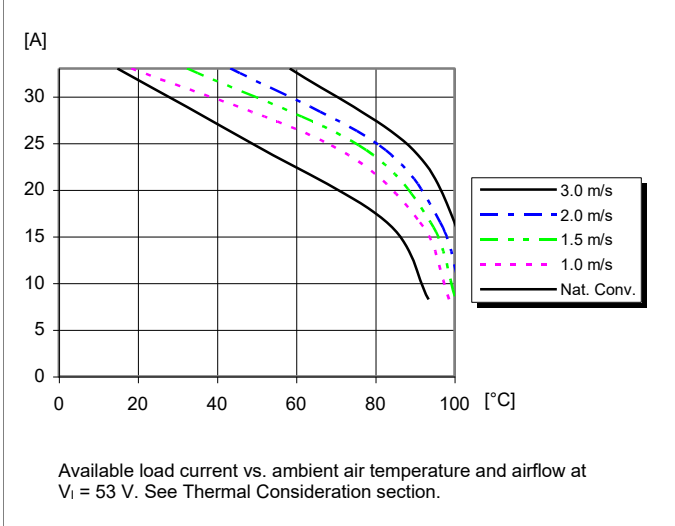

Output Current Derating, base plate option

Thermal Resistance, base plate option

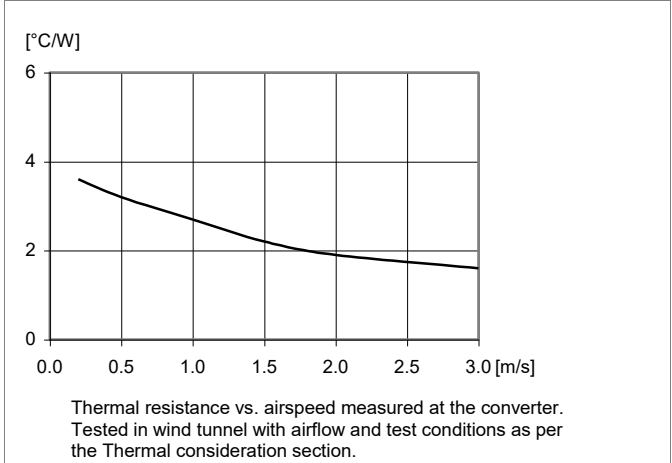
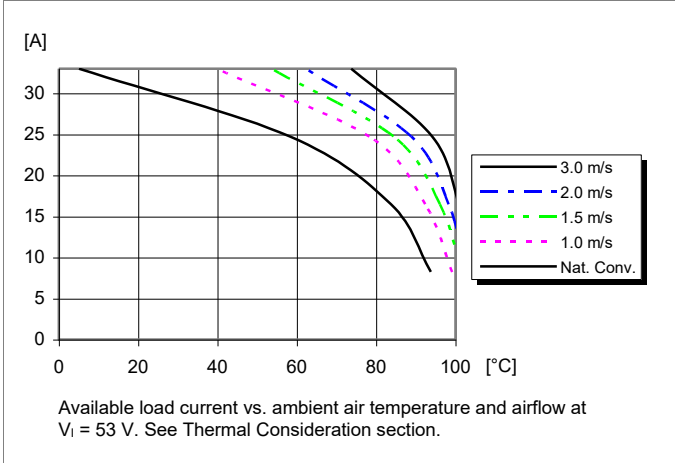

Technical Specification

PKM 4304 Series DC-DC Converters
 Input 40-75 V, Output up to 33 A / 396 W

EN/LZT 146 440 R2A November 2017
 © Flex

12 V/33 A Typical Characteristics

PKM 4304 PI

Start-up

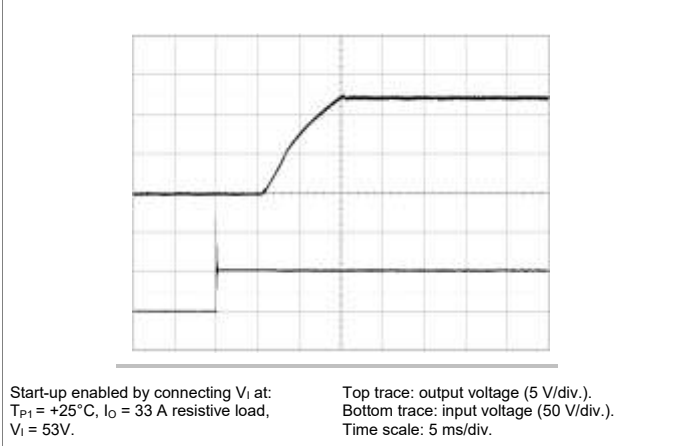

Shut-down

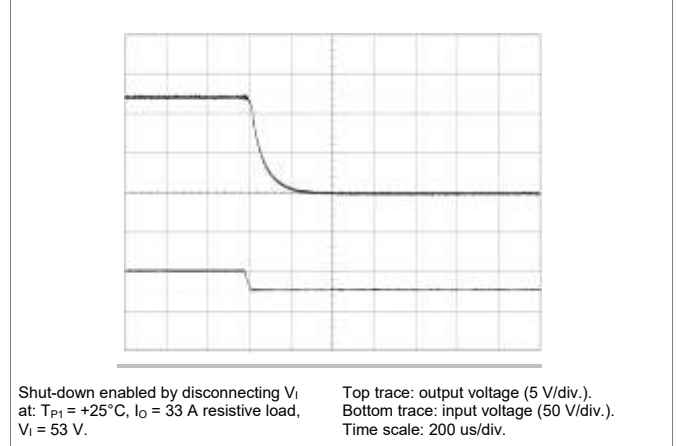

Output Ripple & Noise

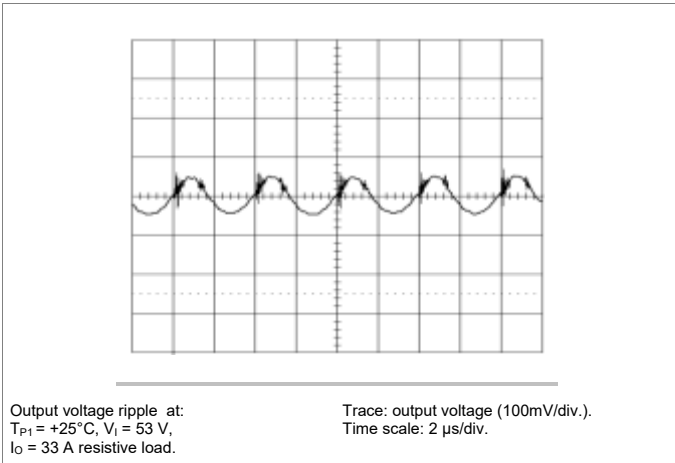

Output Load Transient Response

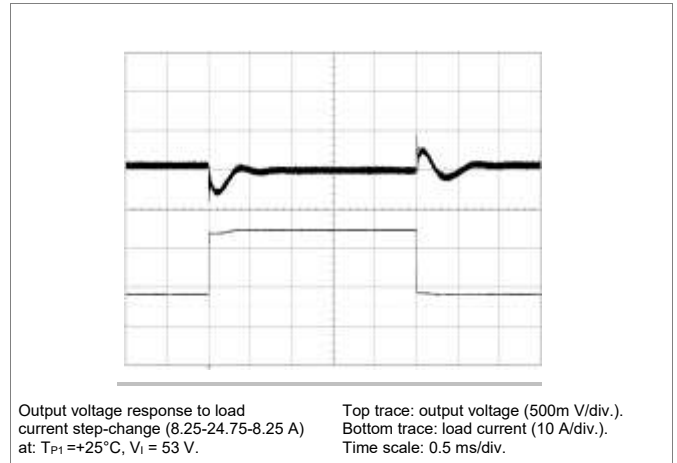

PKM 4304 Series DC-DC Converters
 Input 40-75 V, Output up to 33 A / 396 W

EN/LZT 146 440 R2A November 2017

© Flex

EMC Specification

Conducted EMI measured according to EN55022, CISPR 22 and FCC part 15J (see test set-up). See Design Note 009 for detailed information. The fundamental switching frequency is 125 kHz for PKM 4304 PI at $V_I = 53\text{ V}$, max I_O .

Conducted EMI Input terminal value (typ)

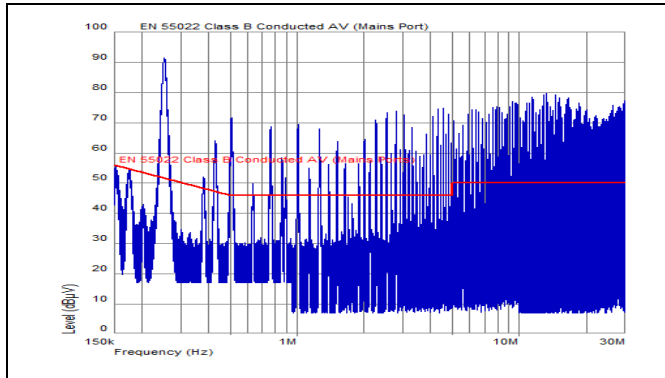

EMI without filter

Optional external filter for class B

Suggested external input filter in order to meet class B in EN 55022, CISPR 22 and FCC part 15J.

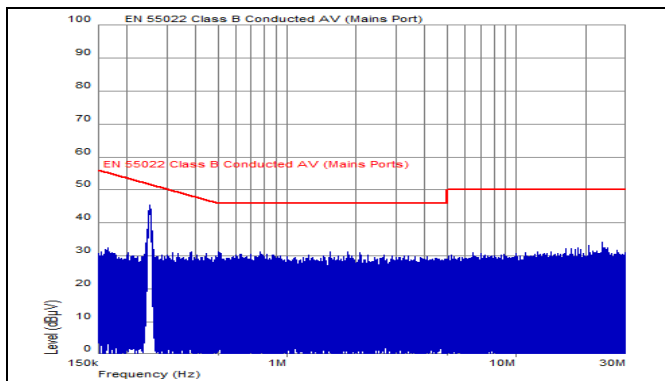
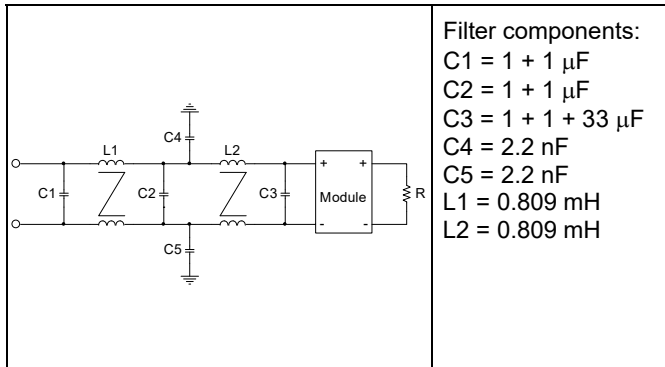

EMI with filter

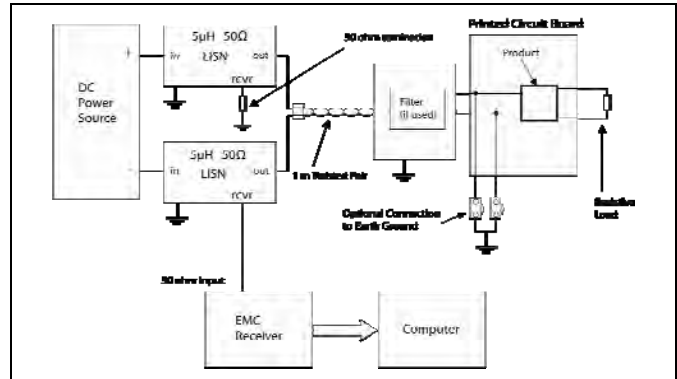

Test set-up

Layout recommendations

The radiated EMI performance of the product will depend on the PWB layout and ground layer design. It is also important to consider the stand-off of the product. If a ground layer is used, it should be connected to the output of the product and the equipment ground or chassis.

A ground layer will increase the stray capacitance in the PWB and improve the high frequency EMC performance.

Output ripple and noise

Output ripple and noise measured according to figure below. See Design Note 022 for detailed information.

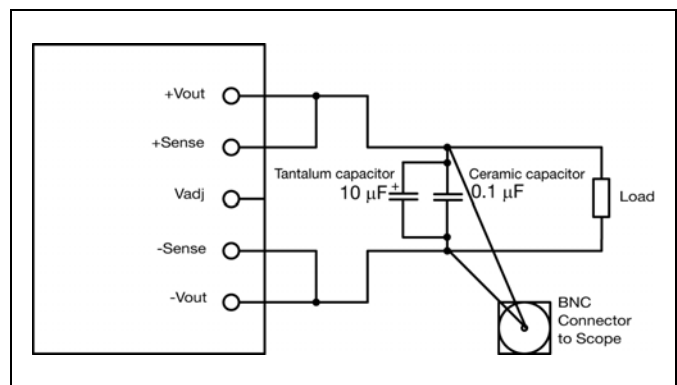

Output ripple and noise test setup

Technical Specification

PKM 4304 Series DC-DC Converters
 Input 40-75 V, Output up to 33 A / 396 W

EN/LZT 146 440 R2A

November 2017

© Flex

Operating information

Input Voltage

The input voltage range 40 to 75 Vdc meets the requirements of the European Telecom Standard ETS 300 132-2 for normal input voltage range in -48 and -60 Vdc systems, -40.5 to -57.0 V and -50.0 to -72 V respectively. At input voltages exceeding 75 V, the power loss will be higher than at normal input voltage and T_{P1} must be limited to absolute max +115°C. The absolute maximum continuous input voltage is 80 Vdc.

Turn-off Input Voltage

The products monitor the input voltage and will turn on and turn off at predetermined levels. The minimum hysteresis between turn on and turn off input voltage is 1 V.

Remote Control (RC)

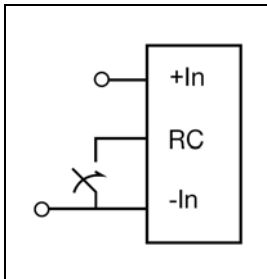

The products are fitted with a remote control function referenced to {the primary negative input connection (-In), with negative and positive logic options available. The RC function allows the product to be turned on/off by an external device like a semiconductor or mechanical switch. The RC pin has an internal pull up resistor to +In.

The device should be capable of sinking 0.7 mA. When the RC pin is left open, the voltage generated on the RC pin is 5.2 V. The standard product is provided with "negative logic" remote control and will be off until the RC pin is connected to the -In. To turn on the product the voltage between RC pin and -In should be less than 1 V. To turn off the product the RC pin should be left open, or connected to a voltage higher than 5 V referenced to -In. In situations where it is desired to have the product to power up automatically without the need for control signals or a switch, the RC pin can be wired directly to -In.

The second option is "positive logic" remote control, which can be ordered by adding the suffix "P" to the end of the part number. When the RC pin is left open, the product starts up automatically when the input voltage is applied. Turn off is achieved by connecting the RC pin to the -In. To ensure safe turn off the voltage difference between RC pin and the -In pin shall be less than 1 V. The product will restart automatically when this connection is opened.

Input and Output Impedance

The impedance of both the input source and the load will interact with the impedance of the product. It is important that the input source has low characteristic impedance. The products are designed for stable operation without external capacitors connected to the input or output. The performance in some applications can be enhanced by addition of external

capacitance as described under External Decoupling Capacitors. If the input voltage source contains significant inductance, the addition of a 22 – 100 μ F capacitor across the input of the product will ensure stable operation. The capacitor is not required when powering the product from an input source with an inductance below 10 μ H. The minimum required capacitance value depends on the output power and the input voltage. The higher output power the higher input capacitance is needed. Approximately doubled capacitance value is required for a 24 V input voltage source compared to a 48V input voltage source.

External Decoupling Capacitors

When powering loads with significant dynamic current requirements, the voltage regulation at the point of load can be improved by addition of decoupling capacitors at the load. The most effective technique is to locate low ESR ceramic and electrolytic capacitors as close to the load as possible, using several parallel capacitors to lower the effective ESR. The ceramic capacitors will handle high-frequency dynamic load changes while the electrolytic capacitors are used to handle low frequency dynamic load changes. Ceramic capacitors will also reduce any high frequency noise at the load. It is equally important to use low resistance and low inductance PWB layouts and cabling. For semi-regulated or fixed turns ratio IBC (intermediate bus converters), there is no limit on the value of external output capacitance, but there are practical performance considerations that need to be made when using very large capacitor values such as ramp-up time of the DC/DC converter output voltage during start-up or turn-off discharge considerations. For further information please contact your local Ericsson Power Modules representative.

Over Temperature Protection (OTP)

The products are protected from thermal overload by an internal over temperature shutdown circuit. When T_{P1} as defined in thermal consideration section exceeds 120°C the product will shut down. The product will make continuous attempts to start up (non-latching mode) and resume normal operation automatically when the temperature has dropped >10°C below the temperature threshold.

Over Voltage Protection (OVP)

The products have output over voltage protection that will shut down the product in over voltage conditions. The product will make continuous attempts to start up (non-latching mode) and resume normal operation automatically after removal of the over voltage condition.

Over Current Protection (OCP)

The products include current limiting circuitry for protection at continuous overload. The output voltage will decrease towards zero for output currents in excess of max output current (max I_o). The product will resume normal operation after removal of the overload. The load distribution should be designed for the maximum output short circuit current specified.

Technical Specification

PKM 4304 Series DC-DC Converters
 Input 40-75 V, Output up to 33 A / 396 W

EN/LZT 146 440 R2A

November 2017

© Flex

Thermal Consideration

General

The products are designed to operate in different thermal environments and sufficient cooling must be provided to ensure reliable operation.

For products mounted on a PWB without a heat sink attached, cooling is achieved mainly by conduction, from the pins to the host board, and convection, which is dependant on the airflow across the product. Increased airflow enhances the cooling of the product. The Output Current Derating graph found in the Output section for each model provides the available output current vs. ambient air temperature and air velocity at $V_i=53$ V.

The product is tested on a 254 x 254 mm, 35 μ m (1 oz), 16-layer test board mounted vertically in a wind tunnel with a cross-section of 608 x 203 mm.

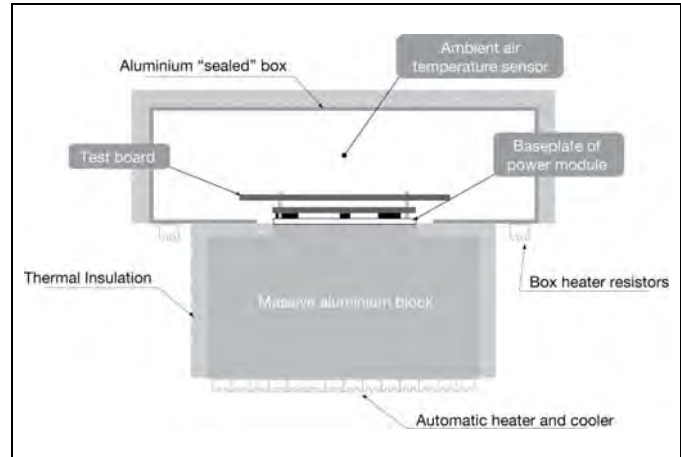

Definition of product operating temperature

The product operating temperatures is used to monitor the temperature of the product, and proper thermal conditions can be verified by measuring the temperature at positions Tref, MOSFET, baseplate and voltage reference. The temperature at these positions should not exceed the maximum temperatures in the table below. The number of measurement points may vary with different thermal design and topology. Temperatures above maximum T_{P1} , measured at the reference point P1 are not allowed and may cause permanent damage.

Position	Description	Max Temp.
P1	Reference point, PCB	$T_{P1}=120^{\circ}$ C
P2	Mosfet case	$T_{P2}=110^{\circ}$ C
P3	Voltage reference	$T_{P3}=90^{\circ}$ C
P4	baseplate	$T_{P4}=105^{\circ}$ C

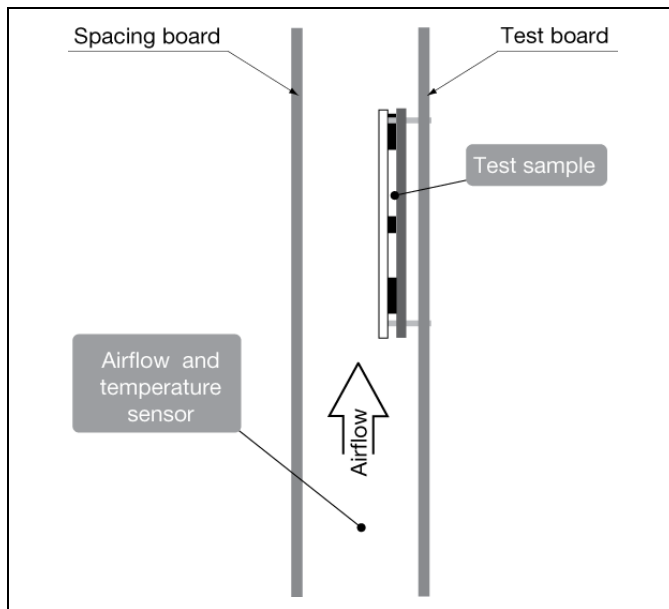

For products with base plate used in a sealed box/cold wall application, cooling is achieved mainly by conduction through the cold wall. The Output Current Derating graphs are found in the Output section for each model. The product is tested in a sealed box test set up with ambient temperatures 85, 55 and 25°C. See Design Note 028 for further details.

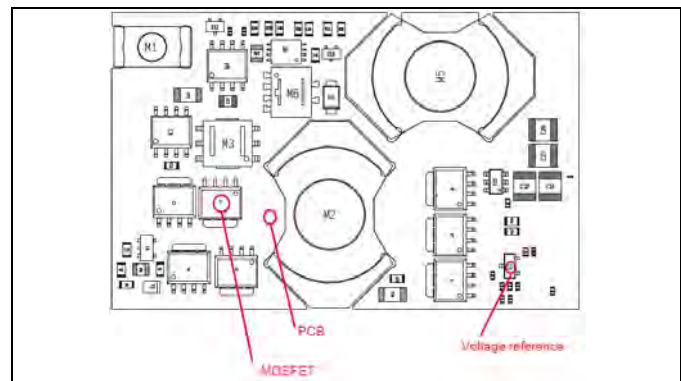

Open frame

Technical Specification

PKM 4304 Series DC-DC Converters
 Input 40-75 V, Output up to 33 A / 396 W

EN/LZT 146 440 R2A November 2017

© Flex

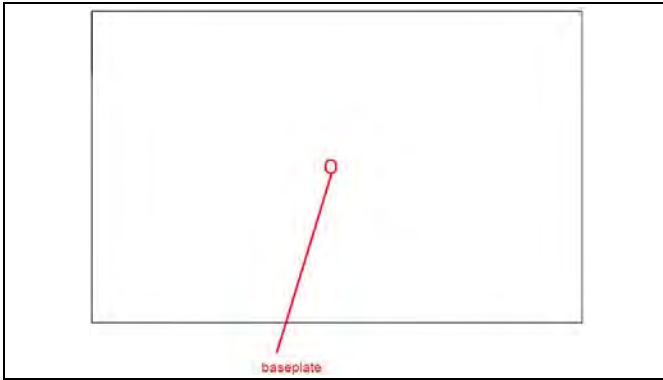

Base plate

Connections

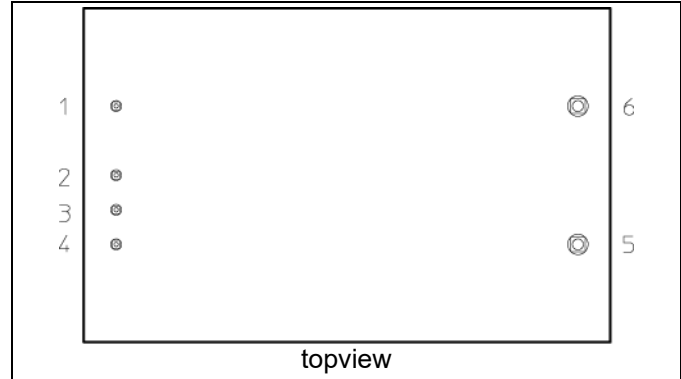

topview

Pin	Designation	Function
1	+In	Positive input
2	RC	Remote control
3	Case	Case to GND (optional)
4	-In	Negative input
5	-Out	Negative output
6	+Out	Positive output

Ambient Temperature Calculation

For products with base plate the maximum allowed ambient temperature can be calculated by using the thermal resistance.

1. The power loss is calculated by using the formula
 $((1/\eta) - 1) \times \text{output power} = \text{power losses (Pd)}$
 η = efficiency of product. E.g. 89.5 % = 0.895

2. Find the thermal resistance (Rth) in the Thermal Resistance graph found in the Output section for each model. **Note that the thermal resistance can be significantly reduced if a heat sink is mounted on the top of the base plate.**

Calculate the temperature increase (ΔT).

$$\Delta T = R_{th} \times P_d$$

3. Max allowed ambient temperature is:

$$\text{Max } T_{P1} - \Delta T.$$

E.g. PKB 4610 PINB at 1m/s:

$$1. ((\frac{1}{0.895}) - 1) \times 66 \text{ W} = 7.74 \text{ W}$$

$$2. 7.74 \text{ W} \times 5.0^\circ\text{C/W} = 38.7^\circ\text{C}$$

$$3. 110^\circ\text{C} - 38.7^\circ\text{C} = \text{max ambient temperature is } 71.3^\circ\text{C}$$

The actual temperature will be dependent on several factors such as the PWB size, number of layers and direction of airflow.

Technical Specification

PKM 4304 Series DC-DC Converters
 Input 40-75 V, Output up to 33 A / 396 W

EN/LZT 146 440 R2A November 2017
 © Flex

Mechanical Information – Through hole mount version

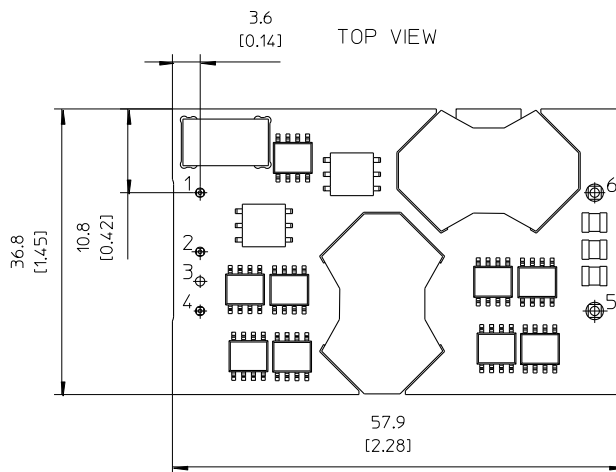
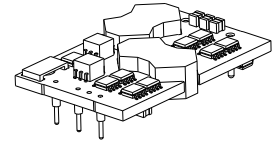
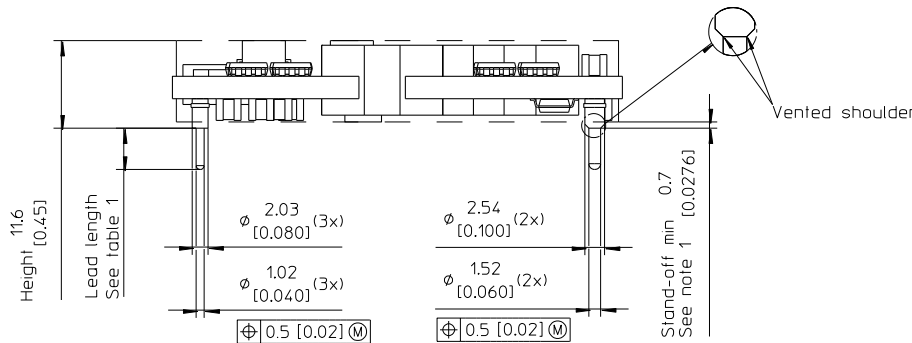

RECOMMENDED FOOTPRINT - TOP VIEW

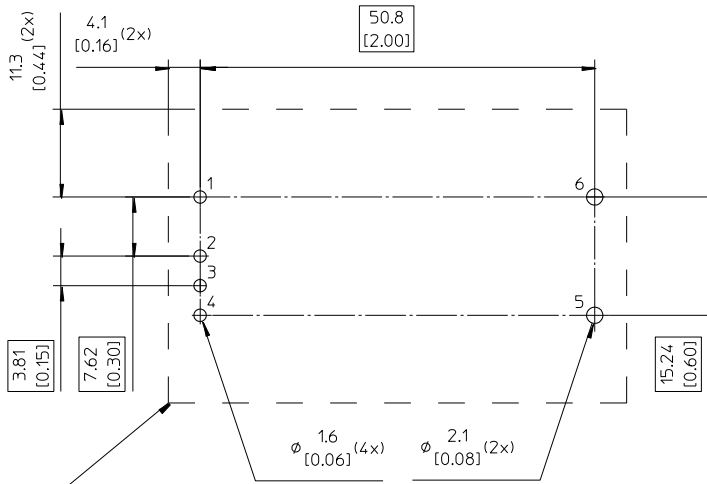

Recommended keep away area for user components.
 The standoff in combination with insulating material ensures that requirements as per IEC/EN/UL60950 are met and 1500 V isolation maintained even if open vias or traces are present under the DC/DC-converter.

Table 1

Pin option	Lead Length
Standard	5.33 [0.210]
LA	3.69 [0.145]
LB	4.57 [0.180]
LC	2.79 [0.110]

Pins:
 Material: Copper alloy
 Plating: 0,1 µm Gold over 2 µm Nickel
 Pin 3 is optional and only used for base plate connection

Notes
 1- Stand off to none conductive components min 0.7 [0.027]
 Stand off to conductive components min 0.95 [0.037]
 For details see safety section page 3.

Weight: Typical 48 g
 All dimensions in mm [inch].
 Tolerances unless specified
 x.x mm ±0.50 [0.02], x.xx mm ±0.25 [0.01]
 (not applied on footprint or typical values)

Technical Specification

PKM 4304 Series DC-DC Converters
 Input 40-75 V, Output up to 33 A / 396 W

EN/LZT 146 440 R2A November 2017
 © Flex

Mechanical Information- Base plate

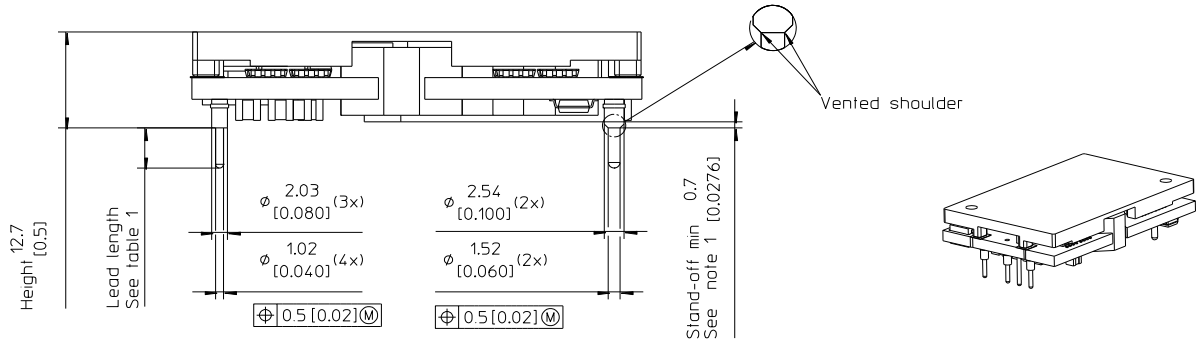

TOP VIEW

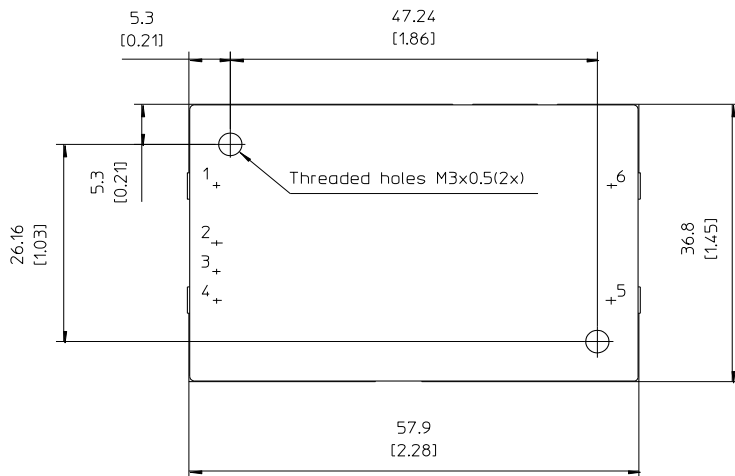

RECOMMENDED FOOTPRINT - TOP VIEW

Table 1

Pin option	Lead Length
Standard	5.33 [0.210]
LA	3.69 [0.145]
LB	4.57 [0.180]
LC	2.79 [0.110]

Case:
 Material: Aluminium
 - For screw attachment apply mounting torque of max 0.44 Nm [3.9 lbf in].
 - M3 screws must not protrude more than 2.7 [0.106] in to the base plate.

Pins:
 Material: Copper alloy
 Plating: 0,1 µm Gold over 2 µm Nickel
 Pin 3 is optional and only used for base plate connection

Notes
 1- Stand off to none conductive components min 0.7 [0.027]
 Stand off to conductive components min 0.95 [0.037]
 For details see safety section page 3.

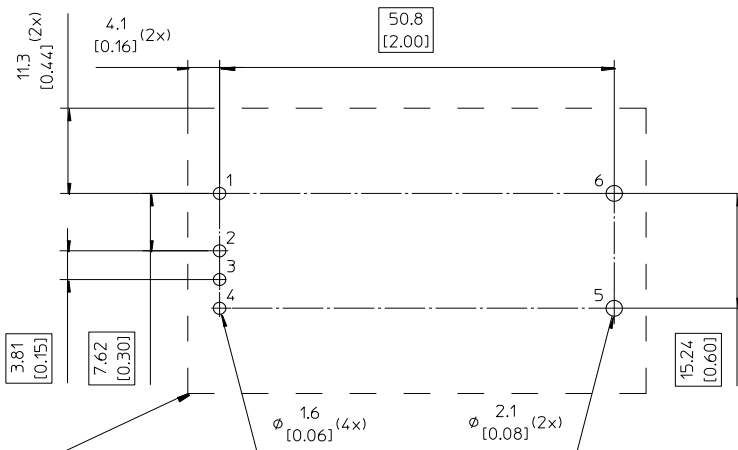

Recommended keep away area for user components.
 The standoff in combination with insulating material ensures that requirements as per IEC/EN/UL60950 are met and 1500 V isolation maintained even if open vias or traces are present under the DC/DC-converter.

Weight: Typical 67 g
 All dimensions in mm [inch].
 Tolerances unless specified
 x.x mm ±0.50 [0.02], x.xx mm ±0.25 [0.01]
 (not applied on footprint or typical values)

Technical Specification

PKM 4304 Series DC-DC Converters
 Input 40-75 V, Output up to 33 A / 396 W

EN/LZT 146 440 R2A November 2017
 © Flex

Soldering Information – Surface Mounting

The surface mount product is intended for forced convection or vapor phase reflow soldering in SnPb and Pb-free processes.

The reflow profile should be optimised to avoid excessive heating of the product. It is recommended to have a sufficiently extended preheat time to ensure an even temperature across the host PCB and it is also recommended to minimize the time in reflow.

A no-clean flux is recommended to avoid entrapment of cleaning fluids in cavities inside the product or between the product and the host board, since cleaning residues may affect long time reliability and isolation voltage.

Minimum Pin Temperature Recommendations

Pin number 5 is chosen as reference location for the minimum pin temperature recommendation since this will likely be the coolest solder joint during the reflow process.

SnPb solder processes

For SnPb solder processes, a pin temperature (T_{PIN}) in excess of the solder melting temperature, (T_L , 183°C for Sn63Pb37) for more than 30 seconds and a peak temperature of 210°C is recommended to ensure a reliable solder joint.

For dry packed products only: depending on the type of solder paste and flux system used on the host board, up to a recommended maximum temperature of 245°C could be used, if the products are kept in a controlled environment (dry pack handling and storage) prior to assembly.

Lead-free (Pb-free) solder processes

For Pb-free solder processes, a pin temperature (T_{PIN}) in excess of the solder melting temperature (T_L , 217 to 221°C for SnAgCu solder alloys) for more than 30 seconds and a peak temperature of 235°C on all solder joints is recommended to ensure a reliable solder joint.

Maximum Product Temperature Requirements

Top of the product PCB near pin 2 is chosen as reference location for the maximum (peak) allowed product temperature ($T_{PRODUCT}$) since this will likely be the warmest part of the product during the reflow process.

SnPb solder processes

For SnPb solder processes, the product is qualified for MSL 1 according to IPC/JEDEC standard J-STD-020C.

During reflow $T_{PRODUCT}$ must not exceed 225 °C at any time.

Pb-free solder processes

For Pb-free solder processes, the product is qualified for MSL 3 according to IPC/JEDEC standard J-STD-020C.

During reflow $T_{PRODUCT}$ must not exceed 260 °C at any time.

Dry Pack Information

Products intended for Pb-free reflow soldering processes are delivered in standard moisture barrier bags according to IPC/JEDEC standard J-STD-033 (Handling, packing, shipping and use of moisture/reflow sensitivity surface mount devices).

Using products in high temperature Pb-free soldering processes requires dry pack storage and handling. In case the products have been stored in an uncontrolled environment and no longer can be considered dry, the modules must be baked according to J-STD-033.

Thermocoupler Attachment

Pin 2 for measurement of maximum product temperature $T_{PRODUCT}$

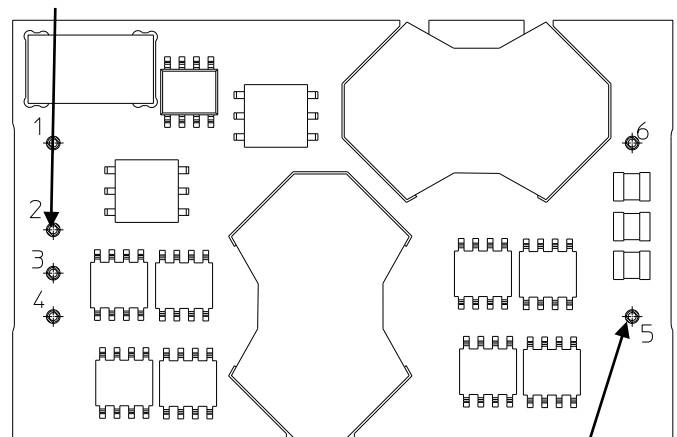

Pin 5 for measurement of minimum Pin (solder joint) temperature T_{PIN}

General reflow process specifications	SnPb eutectic	Pb-free
Average ramp-up ($T_{PRODUCT}$)	3°C/s max	3°C/s max
Typical solder melting (liquidus) temperature	T_L 183°C	221°C
Minimum reflow time above T_L	30 s	30 s
Minimum pin temperature	T_{PIN} 210°C	235°C
Peak product temperature	$T_{PRODUCT}$ 225°C	260°C
Average ramp-down ($T_{PRODUCT}$)	6°C/s max	6°C/s max
Maximum time 25°C to peak	6 minutes	8 minutes

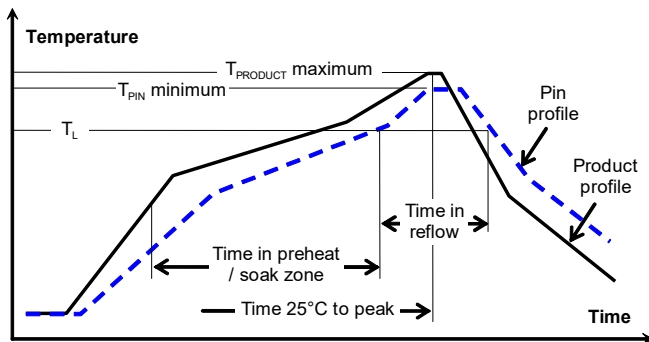

Technical Specification

PKM 4304 Series DC-DC Converters
 Input 40-75 V, Output up to 33 A / 396 W

EN/LZT 146 440 R2A November 2017
 © Flex

Soldering Information - Hole Mounting

The hole mounted product is intended for plated through hole mounting by wave or manual soldering. The pin temperature is specified to maximum to 270°C for maximum 10 seconds.

A maximum preheat rate of 4°C/s and maximum preheat temperature of 150°C is suggested. When soldering by hand, care should be taken to avoid direct contact between the hot soldering iron tip and the pins for more than a few seconds in order to prevent overheating.

A no-clean flux is recommended to avoid entrapment of cleaning fluids in cavities inside the product or between the product and the host board. The cleaning residues may affect long time reliability and isolation voltage.

Delivery Package Information – Hole Mount Version

The products are delivered in antistatic trays.

Tray Specifications	
Material	PE Foam
Surface resistance	$10^5 < \text{Ohm/square} < 10^{12}$
Bakability	The trays are not bakeable
Tray capacity	20 converters/tray
Box capacity	20 products (2 full trays/box)
Weight	Product – Open frame 1100 g full tray, 140g empty tray Product – Base plate option 1480 g full tray, 140 g empty tray

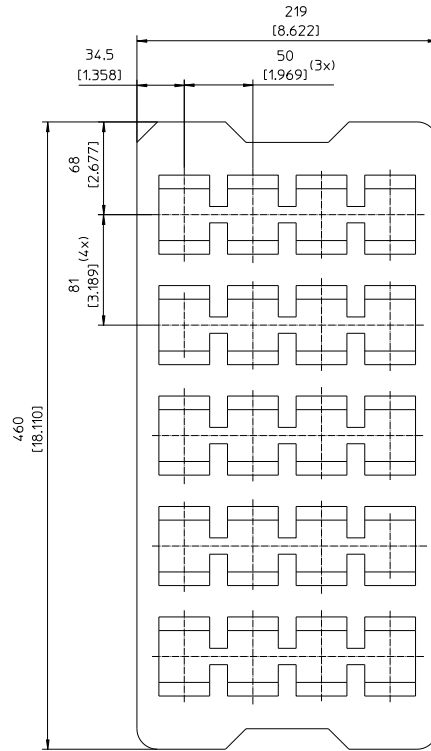

Technical Specification

PKM 4304 Series DC-DC Converters
Input 40-75 V, Output up to 33 A / 396 W

EN/LZT 146 440 R2A November 2017

© Flex

Product Qualification Specification

Characteristics			
External visual inspection	IPC-A-610		
Change of temperature (Temperature cycling)	IEC 60068-2-14 Na	Temperature range Number of cycles Dwell/transfer time	-40 to 100°C 1000 15 min/0-1 min
Cold (in operation)	IEC 60068-2-1 Ad	Temperature T _A Duration	-45°C 72 h
Damp heat	IEC 60068-2-67 Cy	Temperature Humidity Duration	85°C 85 % RH 1000 hours
Dry heat	IEC 60068-2-2 Bd	Temperature Duration	125°C 1000 h
Electrostatic discharge susceptibility	IEC 61340-3-1, JESD 22-A114 IEC 61340-3-2, JESD 22-A115	Human body model (HBM) Machine Model (MM)	Class 2, 2000 V Class 3, 200 V
Immersion in cleaning solvents	IEC 60068-2-45 XA, method 2	Water Glycol ether Isopropyl alcohol	55°C 35°C 35°C
Mechanical shock	IEC 60068-2-27 Ea	Peak acceleration Duration	100 g 6 ms
Moisture reflow sensitivity ¹	J-STD-020C	Level 1 (SnPb-eutectic) Level 3 (Pb Free)	225°C 260°C
Operational life test	MIL-STD-202G, method 108A	Duration	1000 h
Resistance to soldering heat ²	IEC 60068-2-20 Tb, method 1A	Solder temperature Duration	270°C 10-13 s
Robustness of terminations	IEC 60068-2-21 Test Ua1 IEC 60068-2-21 Test Ue1	Through hole mount products Surface mount products	All leads All leads
Solderability	IEC 60068-2-58 test Td ¹	Preconditioning Temperature, SnPb Eutectic Temperature, Pb-free	150°C dry bake 16 h 215°C 235°C
	IEC 60068-2-20 test Ta ²	Preconditioning Temperature, SnPb Eutectic Temperature, Pb-free	Steam ageing 235°C 245°C
Vibration, broad band random	IEC 60068-2-64 Fh, method 1	Frequency Spectral density Duration	10 to 500 Hz 0.07 g ² /Hz 10 min in each direction



Notes

¹ Only for products intended for reflow soldering (surface mount products)







² Only for products intended for wave soldering (plated through hole products)

Looking for pricing, stock, or lifecycle information?

Click below to explore more details on WIN SOURCE:

-  [View PKM4304PI on WIN SOURCE](#)
-  [Flex Power Modules Information](#)

Optimize Your Supply Chain with WIN SOURCE Solutions

-  Global Sourcing Solution
-  Obsolete Management
-  Cost Control Management
-  Shortage Management
-  Alternative Solution
-  Excess Inventory Management