



**THE DATASHEET OF  
PIC18F45K40-I/P**



## Full-Bridge DMOS PWM Motor Driver

### FEATURES AND BENEFITS

- Low  $R_{DS(on)}$  outputs
- Overcurrent protection (OCP)
  - Motor short protection
  - Motor lead short to ground protection
  - Motor lead short to battery protection
- Low Power Standby mode
- Adjustable PWM current limit
- Synchronous rectification
- Internal undervoltage lockout (UVLO)
- Crossover-current protection
- A4950K is AEC-Q100 Grade 1 qualified
- Commercial temperature grade (A4950E:  $-40^{\circ}\text{C}$  to  $85^{\circ}\text{C}$ )
- Automotive temperature grade (A4950K:  $-40^{\circ}\text{C}$  to  $125^{\circ}\text{C}$ )

**PACKAGE: 8-pin SOICN with exposed thermal pad (suffix LJ)**

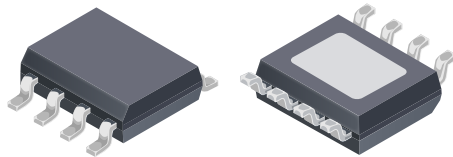

*Not to scale*

### DESCRIPTION

Designed for pulse width modulated (PWM) control of DC motors, the A4950 is capable of peak output currents to  $\pm 3.5\text{ A}$  and operating voltages to 40 V.

Input terminals are provided for use in controlling the speed and direction of a DC motor with externally applied PWM control signals. Internal synchronous rectification control circuitry is provided to lower power dissipation during PWM operation.

Internal circuit protection includes overcurrent protection, motor lead short to ground or supply, thermal shutdown with hysteresis, undervoltage monitoring of  $V_{BB}$ , and crossover-current protection.

For high ambient operating temperature applications, an automotive grade device is offered (A4950K). The K grade device is tested across extended temperature and voltage ranges to ensure compliance in automotive or industrial applications.

The A4950 is provided in a low-profile 8-pin SOICN package with exposed thermal pad (suffix LJ) that is lead (Pb) free, with 100% matte tin leadframe plating.

### Functional Block Diagram

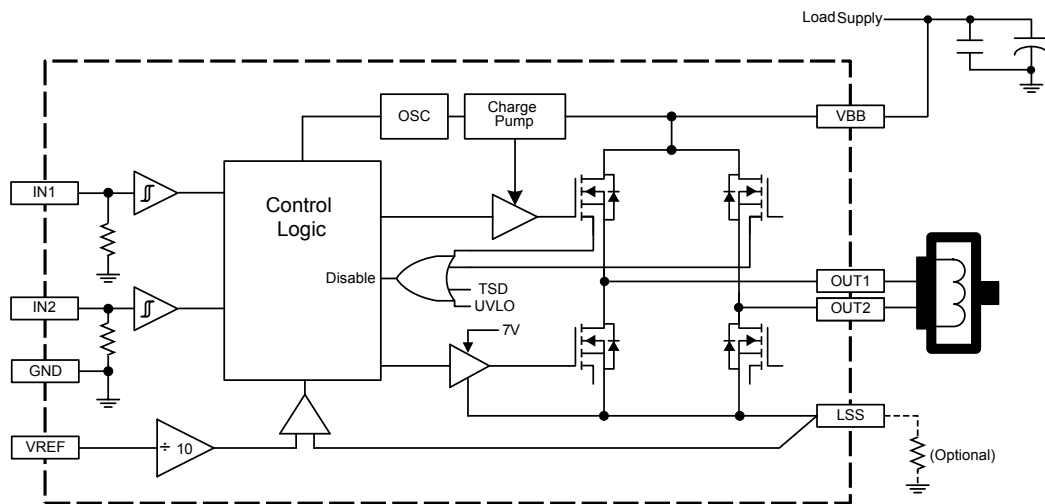

## Selection Guide

Part Number	Packing	Ambient Operating Temperature, $T_A$
A4950ELJTR-T	3000 pieces per 13-in. reel	-40°C to 85°C
A4950KLJTR-T	3000 pieces per 13-in. reel	-40°C to 125°C



## Absolute Maximum Ratings

Characteristic	Symbol	Notes	Rating	Unit
Load Supply Voltage	$V_{BB}$		40	V
Logic Input Voltage Range	$V_{IN}$		-0.3 to 6	V
$V_{REF}$ Input Voltage Range	$V_{REF}$		-0.3 to 6	V
Sense Voltage (LSS pin)	$V_S$		-0.5 to 0.5	V
Motor Outputs Voltage	$V_{OUT}$		-2 to 42	V
Output Current	$I_{OUT}$	Duty cycle = 100%	3.5	A
Transient Output Current	$i_{OUT}$	$T_W < 500$ ns	6	A
Operating Temperature Range	$T_A$	Temperature Range E	-40 to 85	°C
		Temperature Range K	-40 to 125	°C
Maximum Junction Temperature	$T_J(\text{max})$		150	°C
Storage Temperature Range	$T_{stg}$		-55 to 150	°C

**Thermal Characteristics** may require derating at maximum conditions, see application information

Characteristic	Symbol	Test Conditions*	Value	Unit
Package Thermal Resistance	$R_{\theta JA}$	On 2-layer PCB with 0.8 in <sup>2</sup> exposed 2-oz. copper each side	62	°C/W
		On 4-layer PCB based on JEDEC standard	35	°C/W

\*Additional thermal information available on the Allegro website.

## Pinout Diagram

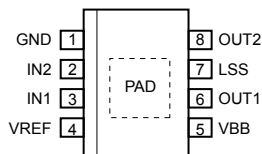

## Terminal List Table

Number	Name	Function
1	GND	Ground
2	IN2	Logic input 2
3	IN1	Logic input 1
4	VREF	Analog input
5	VBB	Load supply voltage
6	OUT1	DMOS full bridge output 1
7	LSS	Power return – sense resistor connection
8	OUT2	DMOS full bridge output 2
–	PAD	Exposed pad for enhanced thermal dissipation

**ELECTRICAL CHARACTERISTICS** Valid for Temperature Range E version at  $T_J = 25^\circ\text{C}$  and for Temperature Range K version at  $T_J = -40^\circ\text{C}$  to  $150^\circ\text{C}$ ,  $V_{BB} = 8$  to  $40\text{ V}$ , unless otherwise specified

Characteristic	Symbol	Test Conditions	Min.	Typ.	Max.	Unit
<b>General</b>						
Load Supply Voltage Range	$V_{BB}$		8	–	40	V
$R_{DS(on)}$ Sink + Source Total	$R_{DS(on)}$	$I_{OUT} =  2.5\text{ A} $ , $T_J = 25^\circ\text{C}$	–	0.6	0.8	$\Omega$
		$I_{OUT} =  2.5\text{ A} $ , $T_J = 150^\circ\text{C}$	–	1.1	1.5	$\Omega$
Load Supply Current	$I_{BB}$	$f_{PWM} < 30\text{ kHz}$	–	10	20	mA
		Low Power Standby mode	–	–	10	$\mu\text{A}$
Body Diode Forward Voltage	$V_f$	Source diode, $I_f = -2.5\text{ A}$	–	–	1.5	V
		Sink diode, $I_f = 2.5\text{ A}$	–	–	1.5	V
<b>Logic Inputs</b>						
Logic Input Voltage Range	$V_{IN(1)}$		2.0	–	–	V
	$V_{IN(0)}$		–	–	0.8	V
	$V_{IN(STANDBY)}$	Low Power Standby mode	–	–	0.4	V
Logic Input Current	$I_{IN(1)}$	$V_{IN} = 2.0\text{ V}$	–	40	100	$\mu\text{A}$
	$I_{IN(0)}$	$V_{IN} = 0.8\text{ V}$	–	16	40	$\mu\text{A}$
Logic Input Pull-Down Resistance	$R_{LOGIC(PD)}$	$V_{IN} = 0\text{ V} = IN1 = IN2$	–	50	–	k $\Omega$
Input Hysteresis	$V_{HYS}$		–	250	550	mV
<b>Timing</b>						
Crossover Delay	$t_{COD}$		50	–	500	ns
$V_{REF}$ Input Voltage Range	$V_{REF}$		0	–	5	V
Current Gain	$A_V$	$V_{REF} / I_{SS}$ , $V_{REF} = 5\text{ V}$	9.5	–	10.5	V/V
		$V_{REF} / I_{SS}$ , $V_{REF} = 2.5\text{ V}$	9.0	–	10.0	V/V
		$V_{REF} / I_{SS}$ , $V_{REF} = 1\text{ V}$	8.0	–	10.0	V/V
Blank Time	$t_{BLANK}$		2	3	4	$\mu\text{s}$
Constant Off-time	$t_{off}$		16	25	34	$\mu\text{s}$
Standby Timer	$t_{st}$	$IN1 = IN2 < V_{IN(STANDBY)}$	–	1	1.5	ms
Power-Up Delay	$t_{pu}$		–	–	30	$\mu\text{s}$
<b>Protection Circuits</b>						
UVLO Enable Threshold	$V_{BBUVLO}$	$V_{BB}$ increasing	7	7.5	7.95	V
UVLO Hysteresis	$V_{BBUVLOhys}$		–	500	–	mV
Thermal Shutdown Temperature	$T_{JTSD}$	Temperature increasing	–	160	–	$^\circ\text{C}$
Thermal Shutdown Hysteresis	$T_{TSDhys}$	Recovery = $T_{JTSD} - T_{TSDhys}$	–	15	–	$^\circ\text{C}$

## CHARACTERISTIC PERFORMANCE

PWM Control Timing Diagram

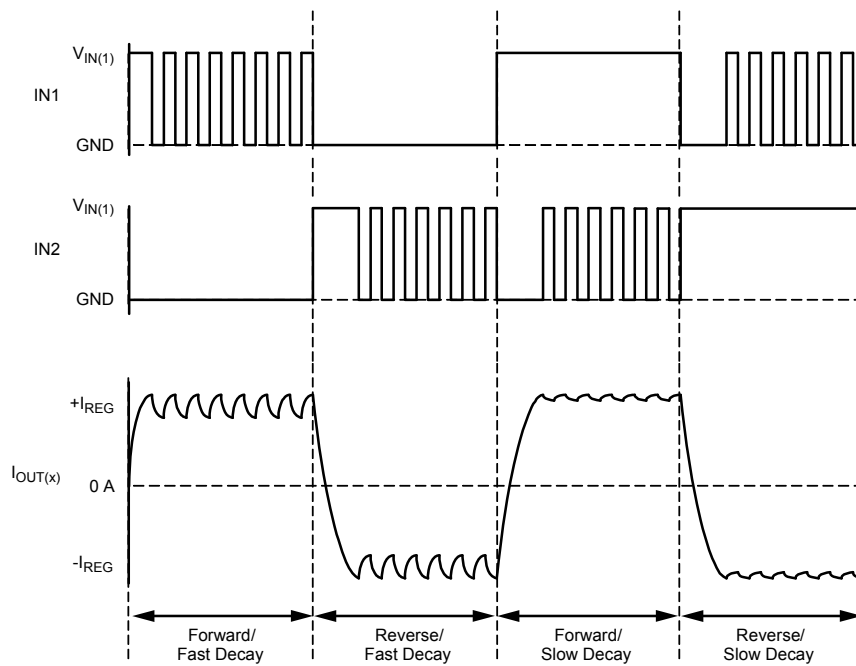

PWM Control Truth Table

IN1	IN2	$10 \times V_S > V_{REF}$	OUT1	OUT2	Function
0	1	False	L	H	Reverse
1	0	False	H	L	Forward
0	1	True	H/L	L	Chop (mixed decay), reverse
1	0	True	L	H/L	Chop (mixed decay), forward
1	1	False	L	L	Brake (slow decay)
0	0	False	Z	Z	Coast, enters Low Power Standby mode after 1 ms

Note: Z indicates high impedance.

## FUNCTIONAL DESCRIPTION

### Device Operation

The A4950 is designed to operate DC motors. The output drivers are all low- $R_{DS(on)}$ , N-channel DMOS drivers that feature internal synchronous rectification to reduce power dissipation. The current in the output full bridge is regulated with fixed off-time pulse width modulated (PWM) control circuitry. The IN1 and IN2 inputs allow two-wire control for the bridge.

Protection circuitry includes internal thermal shutdown, and protection against shorted loads, or against output shorts to ground or supply. Undervoltage lockout prevents damage by keeping the outputs off until the driver has enough voltage to operate normally.

### Standby Mode

Low Power Standby mode is activated when both input (INx) pins are low for longer than 1 ms. Low Power Standby mode disables most of the internal circuitry, including the charge pump and the regulator. When the A4950 is coming out of standby mode, the charge pump should be allowed to reach its regulated voltage (a maximum delay of 30  $\mu$ s) before any PWM commands are issued to the device.

### Internal PWM Current Control

Initially, a diagonal pair of source and sink FET outputs are enabled and current flows through the motor winding and the optional external current sense resistor,  $R_S$ . When the voltage across  $R_S$  equals the comparator trip value, then the current sense comparator resets the PWM latch. The latch then turns off the sink and source FETs (Mixed Decay mode).

### $V_{REF}$

The maximum value of current limiting is set by the selection of  $R_{Sx}$  and the voltage at the VREF pin. The transconductance function is approximated by the maximum value of current limiting,

$I_{TripMAX}$  (A), which is set by:

$$I_{TripMAX} = \frac{V_{REF}}{10 \times R_S}$$

where  $V_{REF}$  is the input voltage on the VREF pin (V) and  $R_S$  is the resistance of the sense resistor ( $\Omega$ ) on the LSS terminal.

### Overcurrent Protection

A current monitor will protect the IC from damage due to output shorts. If a short is detected, the IC will latch the fault and disable the outputs. The fault latch can only be cleared by coming out of Low Power Standby mode or by cycling the power to VBB. During OCP events, Absolute Maximum Ratings may be exceeded for a short period of time before the device latches.

### Shutdown

If the die temperature increases to approximately 160°C, the full bridge outputs will be disabled until the internal temperature falls below a hysteresis,  $T_{TSDhys}$ , of 15°C. Internal UVLO is present on VBB to prevent the output drivers from turning-on below the UVLO threshold.

### Braking

The braking function is implemented by driving the device in Slow Decay mode, which is done by applying a logic high to both inputs, after a bridge-enable Chop command (see PWM Control Truth Table). Because it is possible to drive current in both directions through the DMOS switches, this configuration effectively shorts-out the motor-generated BEMF, as long as the Chop command is asserted. The maximum current can be approximated by  $V_{BEMF} / R_L$ . Care should be taken to ensure that the maximum ratings of the device are not exceeded in worse case braking situations: high speed and high-inertia loads.

### Synchronous Rectification

When a PWM off-cycle is triggered by an internal fixed off-time cycle, load current will recirculate. The A4950 synchronous rectification feature turns-on the appropriate DMOSFETs during the current decay, and effectively shorts out the body diodes with the low  $R_{DS(on)}$  driver. This significantly lowers power dissipation. When a zero current level is detected, synchronous rectification is turned off to prevent reversal of the load current.

### Mixed Decay Operation

The bridges operate in Mixed Decay mode. Referring to the lower panel of the figure below, as the trip point is reached, the device goes into fast decay mode for 50% of the fixed off-time period. After this fast decay portion, the device switches to slow decay mode for the remainder of the off-time. During transitions from fast decay to slow decay, the drivers are forced off for the Crossover Delay,  $t_{COD}$ . This feature is added to prevent shoot-through in the bridge. During this “dead time” portion, synchronous rectification is not active, and the device operates in fast decay and slow decay only.

### Mixed Decay Mode Operation

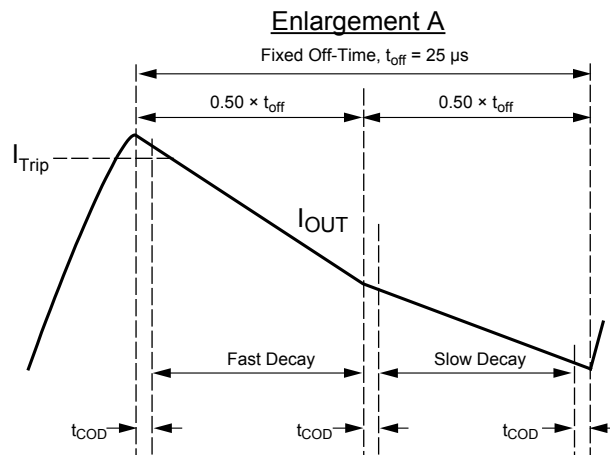
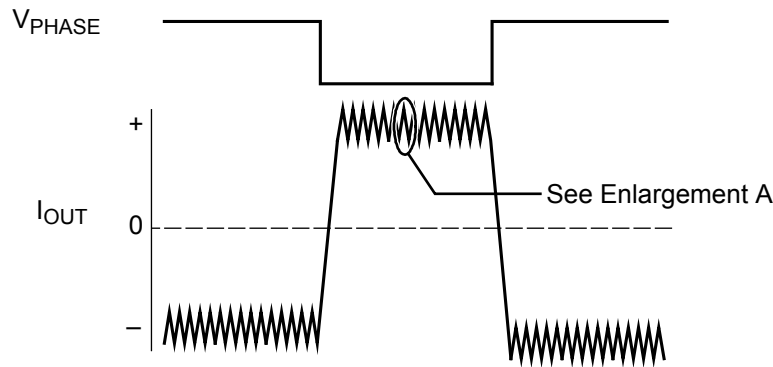

## APPLICATION INFORMATION

### Sense Pin (LSS)

In order to use PWM current control, a low-value resistor is placed between the LSS pin and ground for current sensing purposes. To minimize ground-trace IR drops in sensing the output current level, the current sensing resistor should have an independent ground return to the star ground point. This trace should be as short as possible. For low-value sense resistors, the IR drops in the PCB can be significant, and should be taken into account.

When selecting a value for the sense resistor be sure not to exceed the maximum voltage on the LSS pin of  $\pm 500$  mV at maximum load. During overcurrent events, this rating may be exceeded for short durations.

### Ground

A star ground should be located as close to the A4950 as possible. The copper ground plane directly under the exposed thermal pad

of the device makes a good location for the star ground point. The exposed pad can be connected to ground for this purpose.

### Layout

The PCB should have a thick ground plane. For optimum electrical and thermal performance, the A4950 must be soldered directly onto the board. On the underside of the A4950 package is an exposed pad, which provides a path for enhanced thermal dissipation. The thermal pad must be soldered directly to an exposed surface on the PCB in order to achieve optimal thermal conduction. Thermal vias are used to transfer heat to other layers of the PCB.

The load supply pin, VBB, should be decoupled with an electrolytic capacitor (typically 100  $\mu$ F) in parallel with a lower valued ceramic capacitor placed as close as practicable to the device.

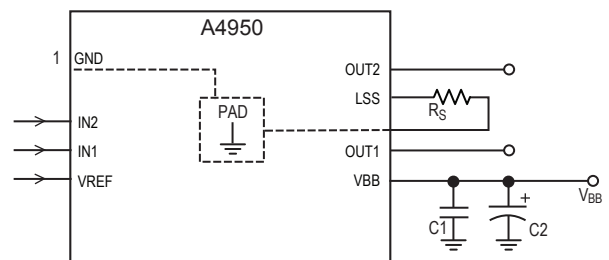
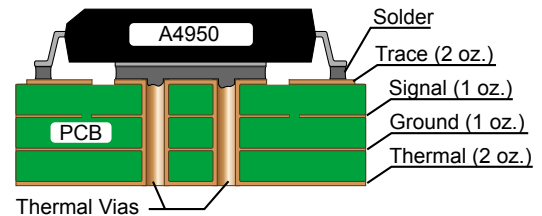
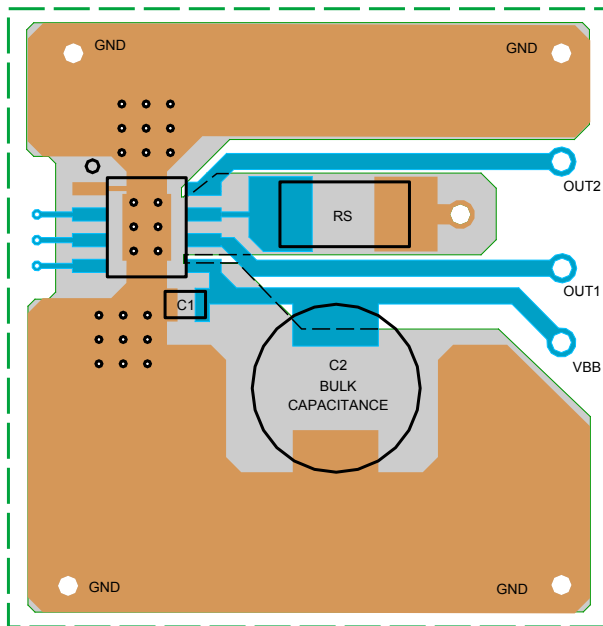

### Bill of Materials

Item	Reference	Value	Units	Description
1	RS	0.25 (for $V_{REF} = 5$ V, $I_{OUT} = 2$ A)	$\Omega$	2512, 1 W, 1% or better, carbon film chip resistor
2	C1	0.22	$\mu$ F	X5R minimum, 50 V or greater
3	C2	100	$\mu$ F	Electrolytic, 50 V or greater

## Package LJ, 8-Pin SOICN with exposed thermal pad

### For Reference Only – Not for Tooling Use

(Reference Allegro DWG-0000380, Rev. 2 and JEDEC MS-012BA)  
 Dimensions in millimeters – NOT TO SCALE  
 Dimensions exclusive of mold flash, gate burrs, and dambar protrusions  
 Exact case and lead configuration at supplier discretion within limits shown

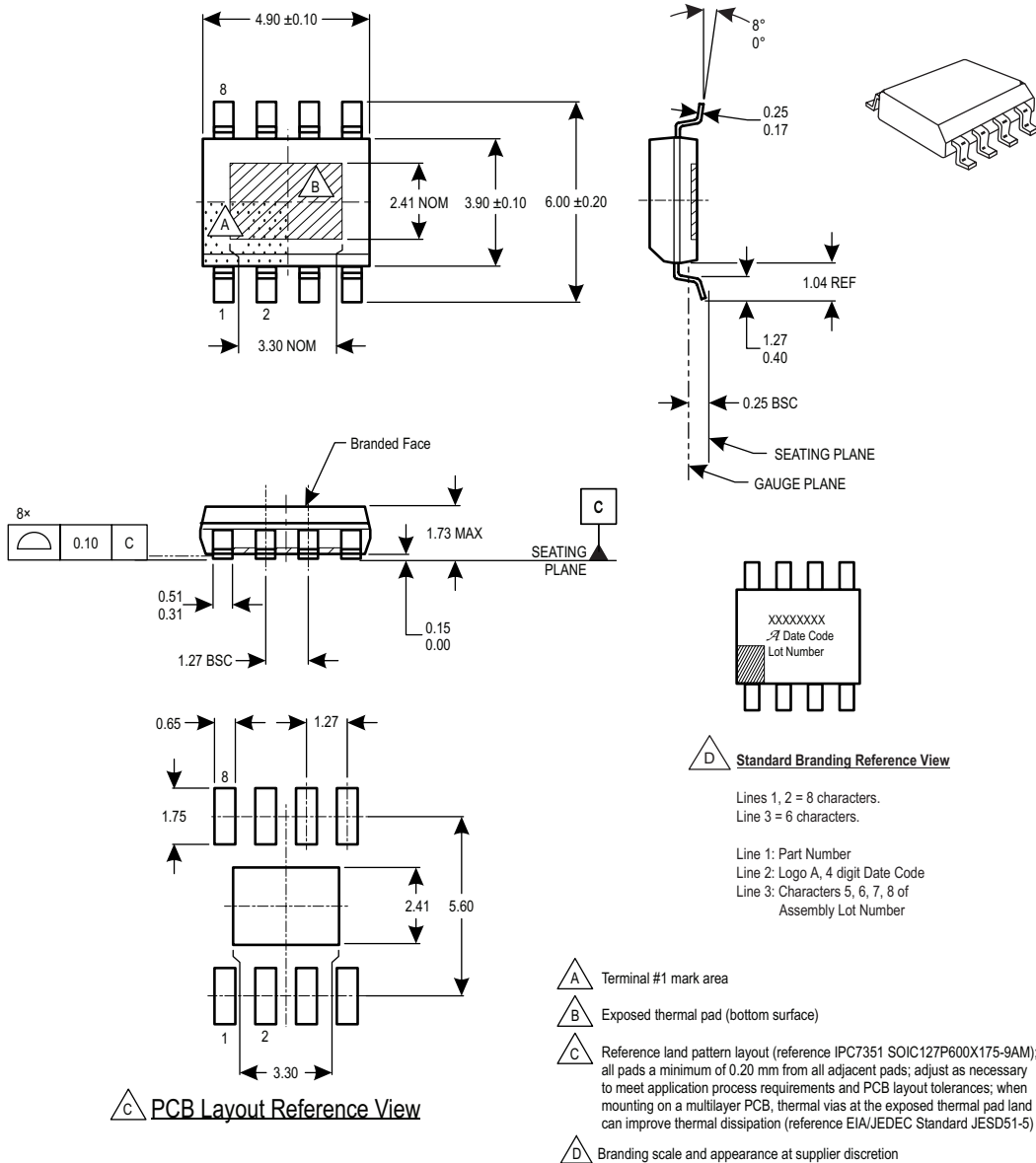

## Revision History

Number	Date	Description
4	August 6, 2012	Add AEC qualification; update PWM table
5	July, 2013	Update standby mode description
6	March 24, 2020	Minor editorial updates
7	March 21, 2022	Updated package drawing (page 8)

Copyright 2022, Allegro MicroSystems.

Allegro MicroSystems reserves the right to make, from time to time, such departures from the detail specifications as may be required to permit improvements in the performance, reliability, or manufacturability of its products. Before placing an order, the user is cautioned to verify that the information being relied upon is current.

Allegro's products are not to be used in any devices or systems, including but not limited to life support devices or systems, in which a failure of Allegro's product can reasonably be expected to cause bodily harm.

The information included herein is believed to be accurate and reliable. However, Allegro MicroSystems assumes no responsibility for its use; nor for any infringement of patents or other rights of third parties which may result from its use.



Copies of this document are considered uncontrolled documents.

For the latest version of this document, visit our website:

[www.allegromicro.com](http://www.allegromicro.com)

## Looking for pricing, stock, or lifecycle information?

Click below to explore more details on WIN SOURCE:

-  [View PIC18F45K40-I/P on WIN SOURCE](#)
-  [Microchip Technology](#) Information

## Optimize Your Supply Chain with WIN SOURCE Solutions

-  Global Sourcing Solution
-  Obsolete Management
-  Cost Control Management
-  Shortage Management
-  Alternative Solution
-  Excess Inventory Management