



**THE DATASHEET OF  
PI6LC48S25BZBBIE**



**Next Generation HiFlex™ Ethernet Network Clock Generator**

**Features**

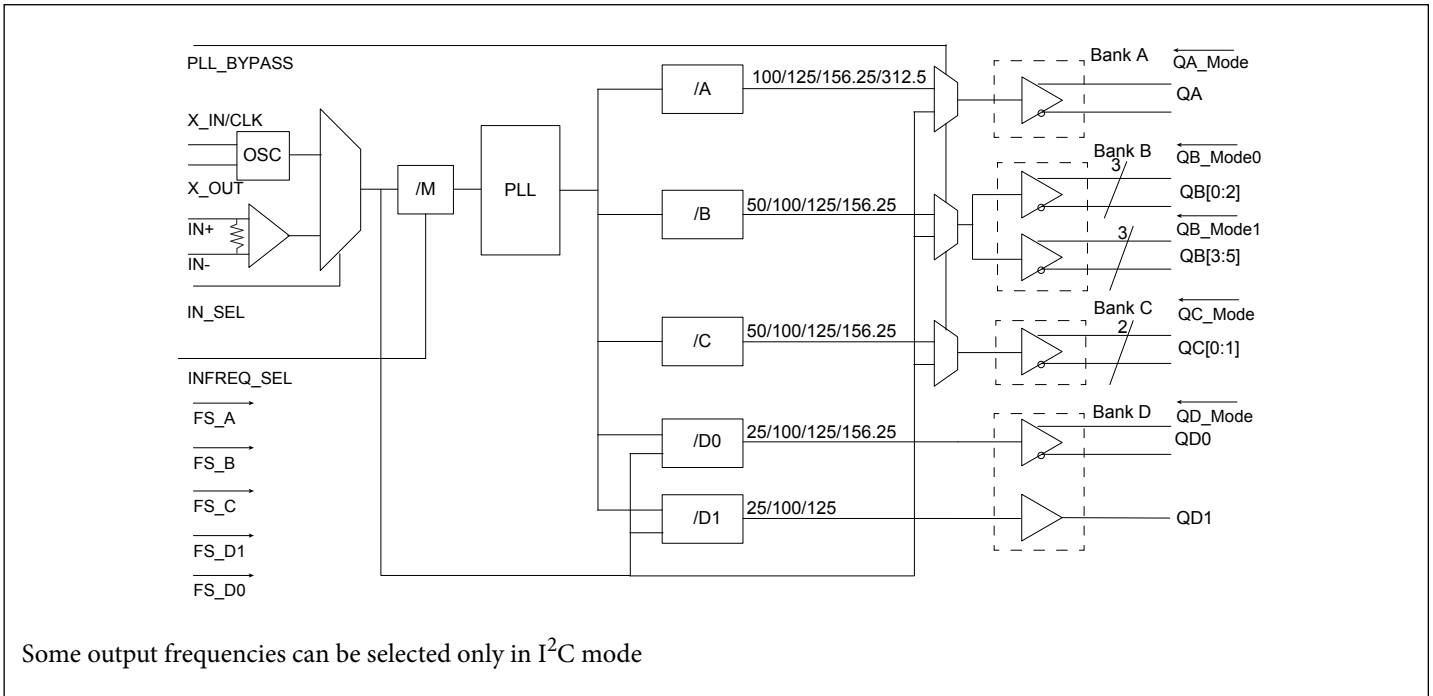
- 3.3V & 2.5V supply voltage
- Crystal/CMOS input: 25 MHz
- Differential input: 25MHz, 125MHz, and 156.25 MHz
- Output frequencies: 312.5, 156.25, 125, 100, 50, 25MHz
- 4 Output banks with selectable output signaling: LVPECL or LVDS
- Low 0.3ps typical integrated phase noise design: 156.25MHz (12kHz to 20MHz)
- PLL Bypass mode for test
- Power supply noise rejection: -52 dBc typical @ VDD
- Packaging (Pb-free & Green): 56-lead 8×8mm TQFN
- Industrial temperature support: -40C to 85C

**Description**

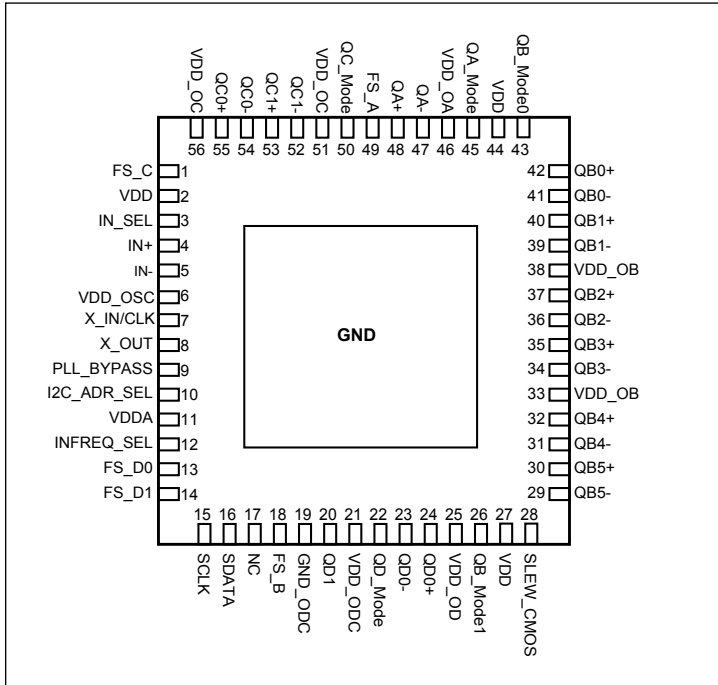
The PI6LC48S25B is an LC VCO based low phase noise design intended for 10GbE applications. Typical 10GbE usage assumes a 25MHz crystal input, while the PLL loop is used to generate the 156.25MHz and other Ethernet clock frequencies. An additional buffered crystal oscillator output is provided to serve as a low noise reference for other circuitry.

For Ethernet applications other than 10GbE, programmable dividers allow for simultaneous output of 312.5, 156.25, 125, 100, 50, and 25MHz. This device offers both pin selection and I<sup>2</sup>C interface to give more options to meet various system needs.

**Block Diagram**



## Pin Configuration



## Pin Description

Pin #	Pin Name	Type		Description
1	FS_C	Input	Tri-level	Output frequency select for Bank C output
2, 27, 44	VDD	Power	-	Core supply
3	IN_SEL	Input	CMOS	Input select between Xtal and differential input
4	IN+	Input	LVPECL	Differential reference input, also accepts AC-coupled LVDS, CML, HCSL or LVPECL. Differential inputs have an internal 100Ω cross resistor.
5	IN-	Input		
6	VDD_OSC	Power	-	Power supply for Xtal Oscillator circuit
7	X_IN/CLK	Input		Xtal or clock input, connect to a 25MHz Xtal or single-ended clock
8	X_OUT	Output		Xtal output
9	PLL_BYPASS	Input	CMOS	PLL bypass, provide input frequency to Bank A, BankB, and Bank C
10	I2C_ADR_SEL	Input	CMOS	I2C address selection.
11	VDDA	Power	-	Analog supply
12	INFREQ_SEL	Input	Tri-level	Input frequency selection for reference input
13	FS_D0	Input	Tri-level	Output frequency select for Bank D differential output
14	FS_D1	Input	Tri-level	Output frequency select for Bank D CMOS output
15	SCLK	Input		I <sup>2</sup> C clock input
16	SDATA	Input/ Output		I <sup>2</sup> C Data line

**Pin Description Cont.**

Pin #	Pin Name	Type		Description
17	NC			Reserved pin. Do not connect this pin
18	FS_B	Input	Tri-level	Output frequency select for Bank B
19	GND_ODC	Power		Ground for bank D CMOS output
20	QD1	Output	CMOS	Bank D output 1
21	VDD_ODC	Power		Power supply for bank D CMOS output
22	QD_Mode	Input	Tri-level	Bank D differential output control
23, 24	QD0-, QD0+	Output	LVPECL/ LVDS	Bank D differential output
25	VDD_OD	Power		Power supply for bank D differential outputs
26	QB_Mode1	Input	Tri-level	Bank B QB3 ~ QB5 differential output control
28	SLEW_CMOS	Input	CMOS	Output slew rate control for the CMOS output
29, 30	QB5-, QB5+	Output	LVPECL/ LVDS	Bank B differential output
31, 32	QB4-, QB4+	Output	LVPECL/ LVDS	Bank B differential output
33, 38	VDD_OB	Power		Power supply for bank B differential outputs
34, 35	QB3-, QB3+	Output	LVPECL/ LVDS	Bank B differential output
36, 37	QB2-, QB2+	Output	LVPECL/ LVDS	Bank B differential output
39, 40	QB1-, QB1+	Output	LVPECL/ LVDS	Bank B differential output
41, 42	QB0-, QB0+	Output	LVPECL/ LVDS	Bank B differential output
43	QB_Mode0	Input	Tri-level	Bank B QB0 ~ QB2 differential output control
45	QA_Mode	Input	Tri-level	Bank A differential output control
46	VDD_OA	Power		Power supply for bank A differential outputs
47, 48	QA-, QA+	Output	LVPECL/ LVDS	Bank A differential output
49	FS_A	Input	Tri-level	Output frequency select for Bank A
50	QC_Mode	Input	Tri-level	Bank C differential output control
51, 56	VDD_OC	Power		Power supply for bank A differential outputs
52, 53	QC1-, QC1+	Output	LVPECL/ LVDS	Bank C differential output
54, 55	QC0-, QC0+	Output	LVPECL/ LVDS	Bank C differential output
E-pad	GND	Power		Connect to ground, use thermal vias

**PI6LC48S25B**

### Input MUX Selection

IN_SEL	Input Source
0	Crystal Input (X_IN/CLK, X_OUT)
1	Differential Input (IN+, IN-)
NC	Crystal Input (X_IN/CLK, X_OUT)

### Reference Input Frequency Select Table

INFREQ_SEL	Reference Input
0	25MHz
1	125MHz
NC	156.25MHz

### PLL Bypass Control Function

PLL_BYPASS	PLL operation
0	PLL enabled
1	PLL bypassed

### Bank A/B/C/D Differential Output Control

QA_Mode	QA	QB_Mode0	QB[2:0]	QB_Mode1	QB[5:3]	QC_Mode	QC[1:0]	QD_Mode	QD0
0	LVPECL	0	LVPECL	0	LVPECL	0	LVPECL	0	LVPECL
1	LVDS	1	LVDS	1	LVDS	1	LVDS	1	LVDS
NC	Hi-Z	NC	Hi-Z	NC	Hi-Z	NC	Hi-Z	NC	Hi-Z

### Bank A/B/C Output Frequency Control Table

FS_A	Bank A Output Freq.	FS_B	Bank B Output Freq.	FS_C	Bank C Output Freq.
0	156.25MHz	0	156.25MHz	0	156.25MHz
1	125MHz	1	125MHz	1	125MHz
NC	312.5MHz	NC	50MHz	NC	100MHz

### Bank D Output Frequency Control Table

FS_D0	Bank D Diff. Output Freq.	FS_D1	Bank D CMOS Output Freq.
0	156.25MHz	0	Hi-Z
1	125MHz	1	125MHz
NC	f <sub>IN</sub>	NC	f <sub>IN</sub>

### Output Slew Rate Control Table

SLEW_CMOS	Output Slew rate
0	Normal mode
1	Slow mode

### I2C Address Selection Table

I <sup>2</sup> C_ADR_SEL	I2C Address
0	DC (h)
1	DE (h)

## Maximum Ratings

(Above which useful life may be impaired. For user guidelines, not tested.)

Storage Temperature.....	-65°C to +150°C
Supply Voltage to Ground Potential, $V_{DD}$ , $V_{DDA}$ , $V_{DD\_OX}$ .....	-0.5V to +4.6V
ESD Protection (HBM) .....	2000 V

**Note:** Stresses greater than those listed under MAXIMUM RATINGS may cause permanent damage to the device. This is a stress rating only and functional operation of the device at these or any other conditions above those indicated in the operational sections of this specification is not implied. Exposure to absolute maximum rating conditions for extended periods may affect reliability.

## Operating Conditions

Symbol	Parameters	Conditions	Min.	Typ.	Max.	Units
$V_{DD}$	Core Power Supply Voltage		2.97	3.3	3.63	V
			2.375	2.5	2.625	V
$V_{DD\_OX}$	Output Power Supply Voltage		2.97	3.3	3.63	V
			2.375	2.5	2.625	V
$V_{DDA}$	Analog Power Supply Voltage		2.97	3.3	3.63	V
			2.375	2.5	2.625	V
$I_{DD}$	Power Supply Current				50	mA
$I_{DD\_O}$	Power Supply Current for Outputs	All outputs loaded, Diff. outputs are LVPECL			525	mA
		All outputs loaded, Diff. outputs are LVDS			242	mA
$I_{DDA}$	Analog Power Supply Current				45	mA
$T_A$	Ambient Temperature		-40		85	°C

## Input Electrical Characteristics

Symbol	Parameters	Conditions	Min.	Typ.	Max.	Units
$R_{pu}$	Internal pull up resistance			51		KΩ
$R_{dn}$	Internal pull down resistance			51		KΩ
$C_{XTAL}$	Internal capacitance on X_IN and X_OUT pins			12		pF

### LVCMOS DC Electrical Characteristics

Symbol	Parameters	Conditions	Min.	Typ.	Max.	Units
V <sub>IH</sub>	Input High Voltage	V <sub>DD</sub> = 3.3V ±10%	2		V <sub>DD</sub> +0.3	V
		V <sub>DD</sub> = 2.5V ±5%	1.7		V <sub>DD</sub> +0.3	V
V <sub>IL</sub>	Input Low Voltage	V <sub>DD</sub> = 3.3V ±10%	-0.3		0.8	V
		V <sub>DD</sub> = 2.5V ±5%	-0.3		0.5	V
I <sub>IH</sub>	Input High Current	V <sub>IN</sub> = V <sub>DD max.</sub>			150	μA
I <sub>IL</sub>	Input Low Current	V <sub>IN</sub> = 0V	-150			μA
V <sub>OH</sub>	Output High Voltage	V <sub>DD</sub> = V <sub>DD_ODC</sub> = 3.3V ±10%; I <sub>OH</sub> = -12mA	2.6			V
		V <sub>DD</sub> = V <sub>DD_ODC</sub> = 2.5V ±5%; I <sub>OH</sub> = -8mA	1.8			V
V <sub>OL</sub>	Output Low Voltage	V <sub>DD</sub> = V <sub>DD_ODC</sub> = 3.3V ±10%; I <sub>OH</sub> = 12mA			0.5	V
		V <sub>DD</sub> = V <sub>DD_ODC</sub> = 2.5V ±5%; I <sub>OH</sub> = 8mA			0.5	V
T <sub>DC</sub>	Input Duty Cycle		35		65	%
R <sub>OUT</sub>	CMOS Output impedance	V <sub>DD_ODC</sub> = 3.3V		24		Ω
		V <sub>DD_ODC</sub> = 2.5V		30		
C <sub>IN</sub>	Input Capacitance			3.5		pF

### Differential Input DC Characteristics

Symbol	Parameters	Conditions	Min..	Typ.	Max.	Units
V <sub>IH</sub>	Input High Voltage				V <sub>DD</sub> - 0.7	V
V <sub>IL</sub>	Input Low Voltage		V <sub>DD</sub> - 2.0			V
V <sub>CM</sub>	Input Bias Voltage		0.5		V <sub>DD</sub> - 0.85	V
R <sub>IN</sub>	Input Differential Impedance <sup>1</sup>		80	100	120	Ω
V <sub>IN-PP</sub>	Input Differential Swing	Differential peak to peak	0.3		2.6	V

Note: 1. Differential input can be AC or DC coupled.

### Crystal Characteristic

Parameters	Description	Min.	Typ	Max.	Units
OSCmode	Mode of Oscillation	Fundamental			
FREQ	Frequency	10	25	40	MHz
ESR <sup>1</sup>	Equivalent Series Resistance			50	Ω
Cload	Load Capacitance		18		pF
Cshunt	Shunt Capacitance			7	pF
	Drive Level			250	uW

Note: 1. ESR value is dependent upon frequency of oscillation

### LVPECL Output DC Characteristics <sup>(1)</sup>

Symbol	Parameters	Condition	Min.	Typ.	Max.	Units
V <sub>OPP</sub>	Output peak-peak Voltage	Single-ended		0.78		V
V <sub>OH</sub>	Output High Voltage	Outputs terminated with 50Ω to V <sub>DD_OX</sub> - 2V	V <sub>DD_OX</sub> - 1.4		V <sub>DD_OX</sub> - 0.7	V
V <sub>OL</sub>	Output Low Voltage		V <sub>DD_OX</sub> - 2.0		V <sub>DD_OX</sub> - 1.3	V

### LVDS Output DC Characteristics <sup>(1)</sup>

Symbol	Parameters	Condition	Min.	Typ.	Max.	Units
V <sub>OPP</sub>	Output Peak-peak Voltage	Single-ended	0.247		0.454	V
DV <sub>OPP</sub>	V <sub>OPP</sub> Magnitude Change				50	mV
V <sub>OS</sub>	Output Offset Voltage		1.125		1.375	V
DV <sub>OS</sub>	V <sub>OS</sub> Magnitude Change				50	mV

### AC Output Characteristics (see test configurations) <sup>(1)</sup>

T<sub>A</sub>=-40C to 85C; V<sub>DD</sub>=3.3V±10%, V<sub>DD\_O</sub>=3.3V±10%

Symbol	Parameters	Condition	Min.	Typ.	Max.	Units	
f <sub>OUT</sub>	Output Frequency	LVC MOS			125	MHz	
		LVPECL			312.5	MHz	
		LVDS			312.5	MHz	
t <sub>R</sub> / t <sub>F</sub>	Rise and Fall Time; 20% ~80%	LVC MOS	Normal Mode <sup>(2)</sup>	150	400	850	ps
			Slow Mode <sup>(3)</sup>			2.0	ns
		LVPECL, LVDS		250	400	ps	
t <sub>DC</sub>	Duty Cycle	LVC MOS	45		55	%	
		LVPECL, LVDS	48		52	%	
		Bank A at 312.5MHz only	47		53	%	
t <sub>JPHASE</sub>	Integrated phase jitter (RMS)	12kHz-20MHz @ 156.25MHz, 25MHz Xtal input		0.3	0.4	ps	
		10kHz-5MHz @ 25MHz, 25MHz Xtal input		0.33	0.4	ps	
t <sub>JC-C</sub>	Cycle to cycle jitter			28	30	ps	
t <sub>JPK-PK</sub>	Peak to Peak jitter			30	35	ps	
f <sub>N</sub>	Single-Side Band Phase Noise	156.25MHz, 25MHz Xtal input	Offset 1kHz		-117		dBc/Hz
			Offset 10kHz		-130		
			Offset 100kHz		-134		
			Offset 1MHz		-139		
			Offset 10MHz		-154		

## AC Output Characteristics Cont.

$T_A = -40^{\circ}\text{C}$  to  $85^{\circ}\text{C}$ ;  $V_{DD} = 3.3\text{V} \pm 10\%$ ,  $V_{DD\_O} = 3.3\text{V} \pm 10\%$

Symbol	Parameters	Condition	Min.	Typ.	Max.	Units
PSNR	Power Supply Noise Rejection	$V_{DD}$ , 50mVpp, 10k-1.5MHz		-52		dBc
		$V_{DDA}$ , 50mVpp, 10k-1.5MHz		-65		
		$V_{DD\_Ox}$ , 50mVpp, 10k-1.5MHz		-50		
$t_{\text{STARTUP}}$	Start time				10	ms
$t_{\text{LOCK}}$	PLL lock time				20	ms

### Note:

- $V_{DD\_O} = 3.3$  is not valid with  $V_{DD} = 2.5\text{V}$
- Normal mode: All measurements are based on 20% to 80% of the single-ended waveform, Load is 4" trace and 4pF.
- Slow mode: All measurements are based on 20% to 80% of the single-ended waveform, Load is 8" trace and 7pF.

## Serial Data Interface (I<sup>2</sup>C compatible)

PI6LC48S25B is a slave only device that supports block read and block write protocol using a single 7-bit address and read/write bit as shown below.

Read and write block transfers can be stopped after any complete byte transfer.

For full electrical I2C compliance, it is recommended to use external pull-up resistors for SDATA and SCLK. The internal pull-up resistors have a size of 50kΩ typical.

### Address Assignment

A6	A5	A4	A3	A2	A1	A0	R/W
1	1	0	1	1	1	I <sup>2</sup> C_ADR_SEL	1/0

### How to Write

1 bit	7 bits	1 bit	1 bit	8 bits	1 bit	8 bits	1 bit		8 bits	1 bit	1 bit
Start bit	Address	W(0)	Ack	Data Byte (D)	Ack	Data Byte (D+1)	Ack	.....	Data Byte (D+N)	Ack	Stop bit

### How to Read

1 bit	7 bits	1 bit	1 bit	8 bits	1 bit	8 bits	1 bit		8 bits	1 bit	1 bit
Start bit	Address	R(1)	Ack	Data Byte (D)	Ack	Data Byte (D+1)	Ack	.....	Data Byte (D+N)	Ack	Stop bit

## Output Frequency I2C bit Control Table

FS_A (2-bit)	Bank A Freq.
0 0	156.25MHz
0 1	312.5MHz
1 0	125MHz
1 1	100MHz

FS_B (2-bit)	Bank B Freq.
0 0	156.25MHz
0 1	50MHz
1 0	125MHz
1 1	100MHz

FS_C (2-bit)	Bank C Freq.
0 0	156.25MHz
0 1	100MHz
1 0	125MHz
1 1	50MHz

FS_D0 (2-bit)	Diff Freq.
0 0	156.25MHz
0 1	f <sub>IN</sub>
1 0	125MHz
1 1	100MHz

FS_D1 (2-bit)	CMOS Freq.
0 0	Output disabled
0 1	f <sub>IN</sub>
1 0	125MHz
1 1	100MHz

### Input Frequency I2C bit Control Table

INFREQ_SEL (2-bit)	Input Freq.
0 0	25MHz
0 1	156.25MHz
1 0	125MHz
1 1	100MHz

### Byte 0: Output Frequency Selection Register

Bit	Control Function	Description	Type	Power Up Condition	0	1
7	FS_C (1)	Bank C output divider	RW	0	See FS_C I <sup>2</sup> C control table	
6	FS_C (0)		RW	0		
5	FS_B (1)	Bank B output divider	RW	0	See FS_B I <sup>2</sup> C control table	
4	FS_B (0)		RW	0		
3	FS_A (1)	Bank A output divider	RW	0	See FS_A I <sup>2</sup> C control table	
2	FS_A (0)		RW	0		
1	Vendor ID		RW	0		
0	Vendor ID		RW	0		

### Byte 1: Output Frequency Selection and Misc. Register

Bit	Control Function	Description	Type	Power Up Condition	0	1
7	I <sup>2</sup> C pin control	Determine external pins or I <sup>2</sup> C control mode	RW	0	External pins	I <sup>2</sup> C
6	I2C_ADR_SEL	Select I <sup>2</sup> C write address	RW	0	DC(h)	DE(h)
5	INFREQ_SEL (1)	Input frequency selection	RW	0	See INFREQ_SEL I <sup>2</sup> C control table	
4	INFREQ_SEL (0)		RW	0		
3	FS_D1 (1)	Bank D CMOS output divider	RW	1	See FS_D1 I <sup>2</sup> C control table	
2	FS_D1 (0)		RW	1		
1	FS_D0 (1)	Bank D Diff. output divider	RW	1	See FS_D0 I <sup>2</sup> C control table	
0	FS_D0 (0)		RW	1		

### Byte 2: Output Enable Selection for Bank A and Bank B Register

Bit	Control Function	Description	Type	Power Up Condition	0	1
7	Reserved					
6	OE for QB5	Output enable bit for QB5	RW	0	Enable	Disable
5	OE for QB4	Output enable bit for QB4	RW	0	Enable	Disable
4	OE for QB3	Output enable bit for QB3	RW	0	Enable	Disable
3	OE for QB2	Output enable bit for QB2	RW	0	Enable	Disable
2	OE for QB1	Output enable bit for QB1	RW	0	Enable	Disable
1	OE for QB0	Output enable bit for QB0	RW	0	Enable	Disable
0	OE for QA	Output enable bit for QA	RW	0	Enable	Disable

### Byte 3: Output Enable and Output Type Selection for Bank C and D Register

Bit	Control Function	Description	Type	Power Up Condition	0	1
7	Reserved					
6	QD0	Output Type Select QD Diff. output	RW	0	LVPECL	LVDS
5	QC1	Output Type Select QC1	RW	0	LVPECL	LVDS
4	QC0	Output Type Select QC0	RW	0	LVPECL	LVDS
3	OE for QD1	Output enable bit for QD1	RW	0	Enable	Disable
2	OE for QD0	Output enable bit for QD0	RW	0	Enable	Disable
1	OE for QC1	Output enable bit for QC1	RW	0	Enable	Disable
0	OE for QC0	Output enable bit for QC0	RW	0	Enable	Disable

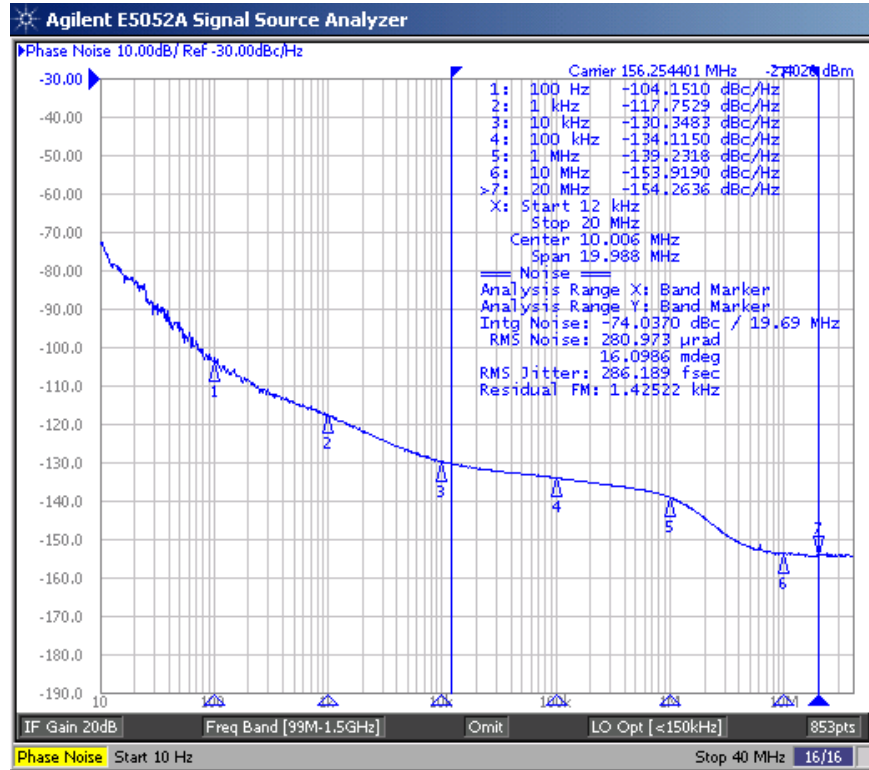
### Byte 4: Output Type Selection for Bank A and Bank B Register

Bit	Control Function	Description	Type	Power Up Condition	0	1
7	Reserved					
6	QB5	Output Type Select QB5	RW	0	LVPECL	LVDS
5	QB4	Output Type Select QB4	RW	0	LVPECL	LVDS
4	QB3	Output Type Select QB3	RW	0	LVPECL	LVDS
3	QB2	Output Type Select QB2	RW	0	LVPECL	LVDS
2	QB1	Output Type Select QB1	RW	0	LVPECL	LVDS
1	QB0	Output Type Select QB0	RW	0	LVPECL	LVDS
0	QA	Output Type Select QA	RW	0	LVPECL	LVDS

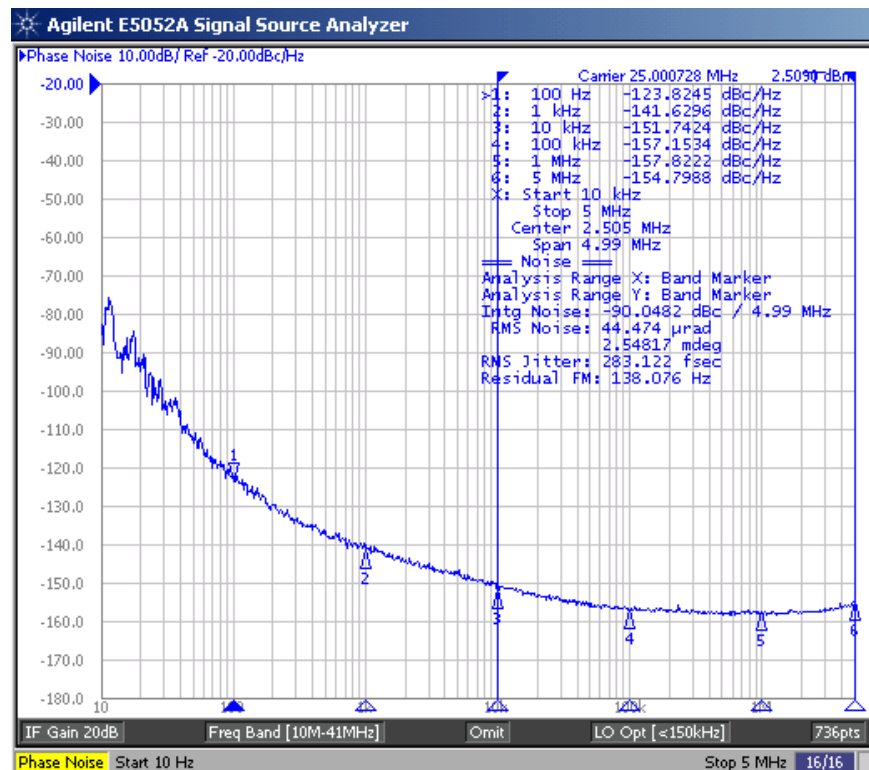
### Byte 5: Misc. Register

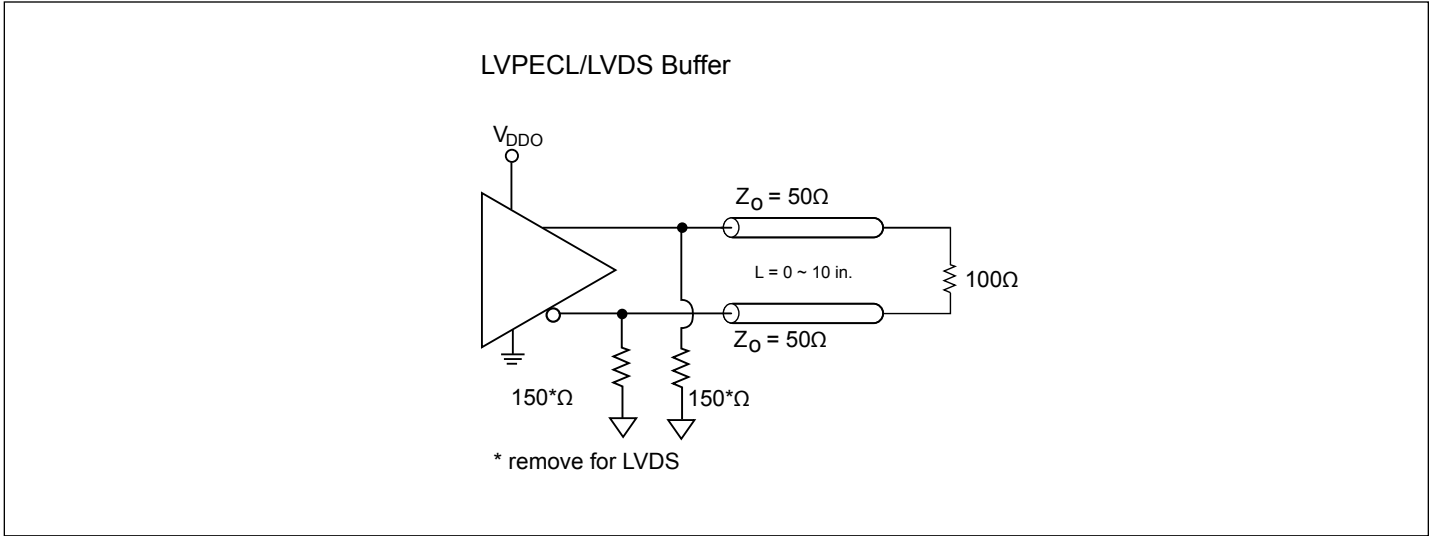
Bit	Control Function	Description	Type	Power Up Condition	0	1
7	Reserved					
6	Reserved			0		
5	Reserved			0		
4	Reserved			0		
3	PLL_BYPASS	PLL bypass function	RW	0	PLL is enabled	PLL is by-passed
2	SLEW_CMOS	Output slew rate control for the CMOS output	RW	0	Normal mode	Slow mode
1	Reserved			0		
0	IN_SEL	Input selection	RW	0	Crystal	Reference

**Phase Noise Plots**  
**156.25MHz LVDS Clock**

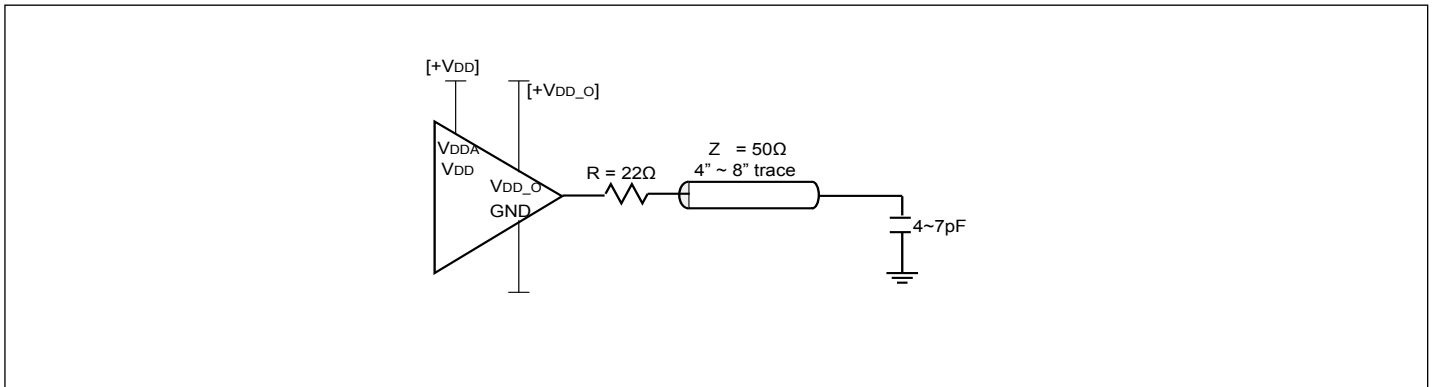


**25MHz LVPECL Clock**

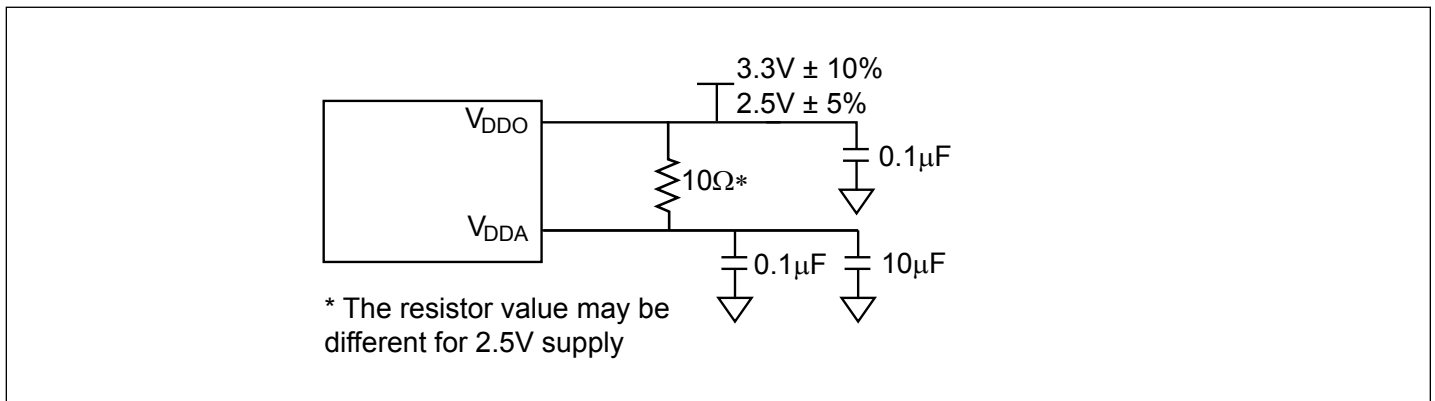




**Figure 1. LVPECL and LVDS Test Circuit**



**Figure 2. CMOS Test Circuit**

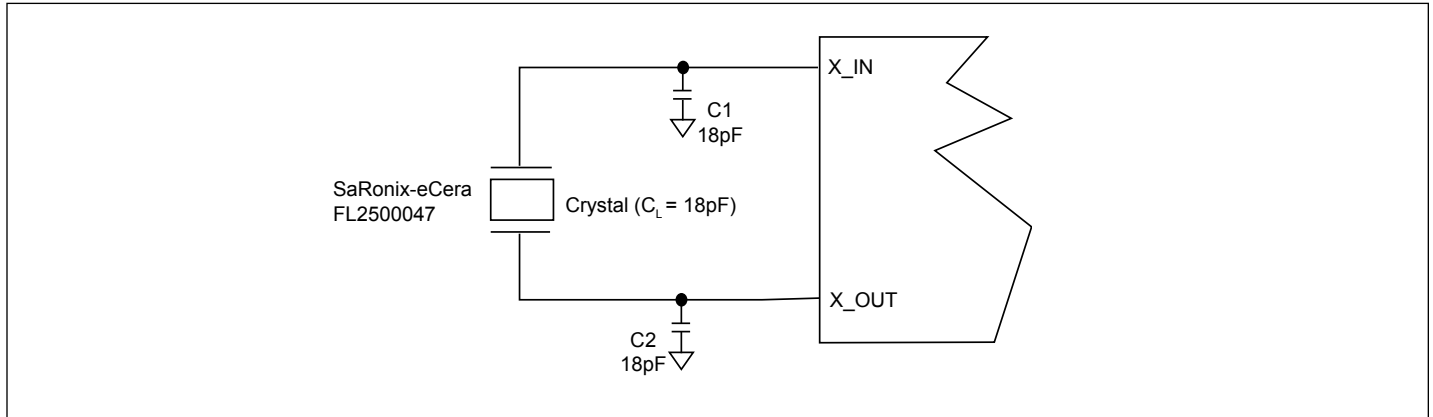


**Figure 3. Power Supply Filter**

## Crystal Circuit Connection

The following diagram shows PI6LC48S25B crystal circuit connection with a parallel crystal. For the  $CL=18\text{pF}$  crystal, it is suggested to use  $C1=18\text{pF}$ ,  $C2=18\text{pF}$ .  $C1$  and  $C2$  can be adjusted to fine tune to the target ppm of crystal oscillator according to different board layouts.

## Crystal Oscillator Circuit



## Crystal Circuit Oscillator

## Recommended Crystal Specification

Pericom recommends:

- FY2500081, SMD 5x3.2(4P), 25MHz,  $CL=18\text{pF}$ ,  $\pm 30\text{ppm}$ , [http://www.pericom.com/pdf/datasheets/se/FY\\_F9.pdf](http://www.pericom.com/pdf/datasheets/se/FY_F9.pdf)
- FL2500047, SMD 3.2x2.5(4P), 25MHz,  $CL=18\text{pF}$ ,  $\pm 20\text{ppm}$ , <http://www.pericom.com/pdf/datasheets/se/FL.pdf>

## Part Marking

ZBB Package



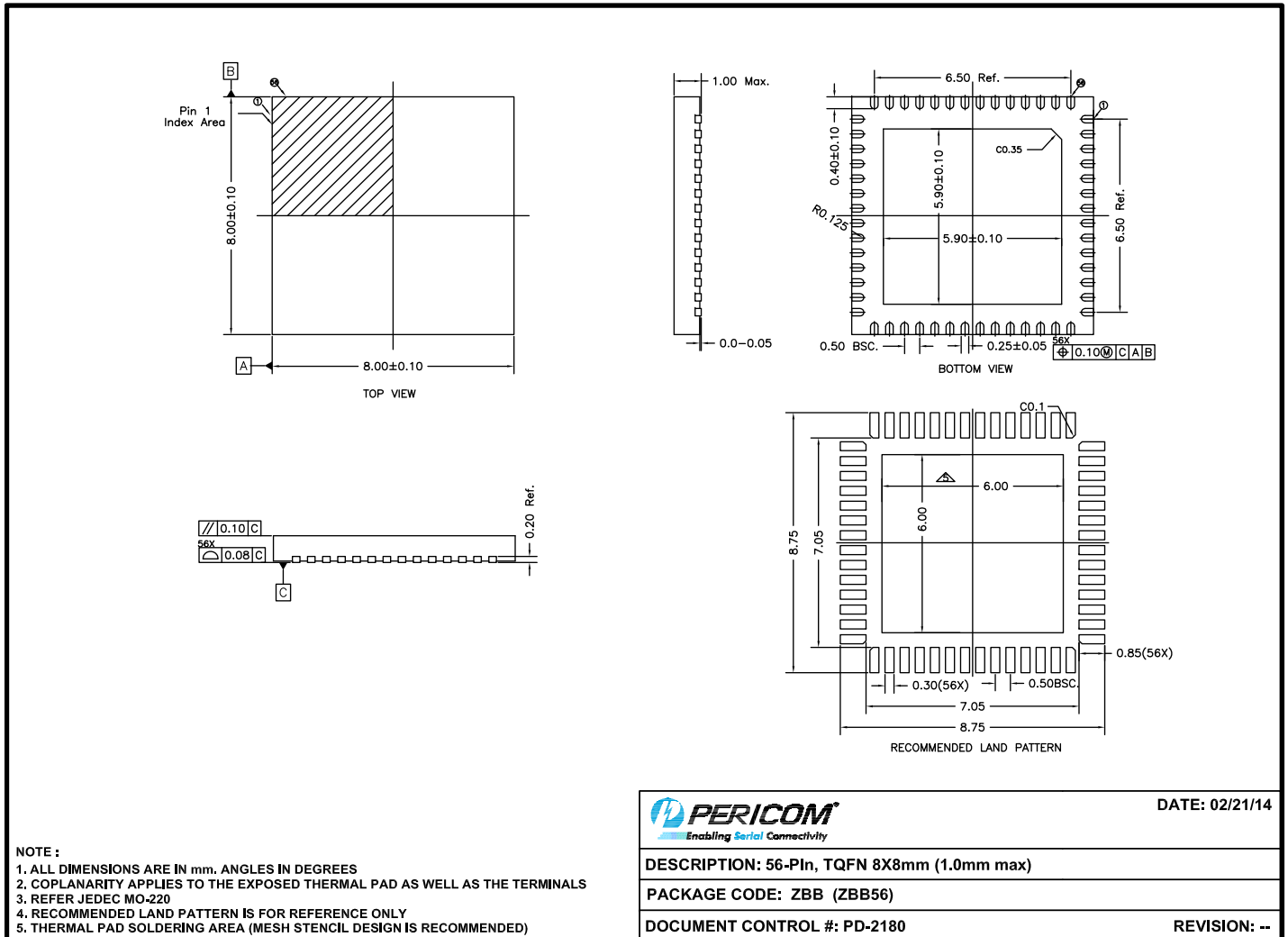
YY: Year

WW: Workweek

1st X: Assembly Code

2nd X: Fab Code

**Packaging Mechanical: 56-TQFN (ZBB)**



For latest package info.

please check: <http://www.diodes.com/design/support/packaging/pericom-packaging/packaging-mechanicals-and-thermal-characteristics/>

**Ordering Information<sup>(1-3)</sup>**

Ordering Code	Package Code	Package Description	Operating Temperature
PI6LC48S25BZBBIEX	ZBB	56-Pin, 8x8mm, 1.0mm max (TQFN)	Industrial

Notes:

1. EU Directive 2002/95/EC (RoHS), 2011/65/EU (RoHS 2) & 2015/863/EU (RoHS 3) compliant. All applicable RoHS exemptions applied.
2. See <http://www.diodes.com/quality/lead-free/> for more information about Diodes Incorporated's definitions of Halogen- and Antimony-free, "Green" and Lead-free. Thermal characteristics can be found on the company web site at [www.diodes.com/design/support/packaging/](http://www.diodes.com/design/support/packaging/)
3. E = Pb-free and Green
4. X suffix = Tape/Reel

**IMPORTANT NOTICE**

DIODES INCORPORATED MAKES NO WARRANTY OF ANY KIND, EXPRESS OR IMPLIED, WITH REGARDS TO THIS DOCUMENT, INCLUDING, BUT NOT LIMITED TO, THE IMPLIED WARRANTIES OF MERCHANTABILITY AND FITNESS FOR A PARTICULAR PURPOSE (AND THEIR EQUIVALENTS UNDER THE LAWS OF ANY JURISDICTION).

Diodes Incorporated and its subsidiaries reserve the right to make modifications, enhancements, improvements, corrections or other changes without further notice to this document and any product described herein. Diodes Incorporated does not assume any liability arising out of the application or use of this document or any product described herein; neither does Diodes Incorporated convey any license under its patent or trademark rights, nor the rights of others. Any Customer or user of this document or products described herein in such applications shall assume all risks of such use and will agree to hold Diodes Incorporated and all the companies whose products are represented on Diodes Incorporated website, harmless against all damages.

Diodes Incorporated does not warrant or accept any liability whatsoever in respect of any products purchased through unauthorized sales channel.

Should Customers purchase or use Diodes Incorporated products for any unintended or unauthorized application, Customers shall indemnify and hold Diodes Incorporated and its representatives harmless against all claims, damages, expenses, and attorney fees arising out of, directly or indirectly, any claim of personal injury or death associated with such unintended or unauthorized application.

Products described herein may be covered by one or more United States, international or foreign patents pending. Product names and markings noted herein may also be covered by one or more United States, international or foreign trademarks.

This document is written in English but may be translated into multiple languages for reference. Only the English version of this document is the final and definitive format released by Diodes Incorporated.

**LIFE SUPPORT**

Diodes Incorporated products are specifically not authorized for use as critical components in life support devices or systems without the express written approval of the Chief Executive Officer of Diodes Incorporated. As used herein:

A. Life support devices or systems are devices or systems which:

1. are intended to implant into the body, or

2. support or sustain life and whose failure to perform when properly used in accordance with instructions for use provided in the labeling can be reasonably expected to result in significant injury to the user.

B. A critical component is any component in a life support device or system whose failure to perform can be reasonably expected to cause the failure of the life support device or to affect its safety or effectiveness.



Customers represent that they have all necessary expertise in the safety and regulatory ramifications of their life support devices or systems, and acknowledge and agree that they are solely responsible for all legal, regulatory and safety-related requirements concerning their products and any use of Diodes Incorporated products in such safety-critical, life support devices or systems, notwithstanding any devices- or systems-related information or support that may be provided by Diodes Incorporated. Further, Customers must fully indemnify Diodes Incorporated and its representatives against any damages arising out of the use of Diodes Incorporated products in such safety-critical, life support devices or systems.

Copyright © 2016, Diodes Incorporated

[www.diodes.com](http://www.diodes.com)

## Looking for pricing, stock, or lifecycle information?

Click below to explore more details on WIN SOURCE:

-  [View PI6LC48S25BZBBIE on WIN SOURCE](#)
-  [Diodes Incorporated Information](#)

## Optimize Your Supply Chain with WIN SOURCE Solutions

-  Global Sourcing Solution
-  Obsolete Management
-  Cost Control Management
-  Shortage Management
-  Alternative Solution
-  Excess Inventory Management