

PI6C5921516

16 Output LVDS Fanout Buffer

Features

- 16 Differential LVDS outputs
- 2 Selectable reference inputs support either single-ended or differential
- Up to 1.5GHz output frequency
- Ultra low additive phase jitter: < 0.01 ps (typ) (differential 156.25MHz, 12KHz to 20MHz integration range)
- Low skew between outputs
- Low delay from input to output
- Separate input output supply voltage for level shifting
- 2.5V / 3.3V power supply
- Industrial temperature support
- TQFN-48 package

Description

The PI6C5921516 is a high performance LVDS fanout buffer device which supports up to 1.5GHz frequency. This device is ideal for systems that need to distribute low jitter LVDS clock signals to multiple destinations.

Applications

- Networking systems including switches and routers
- High frequency backplane based computing and telecom platforms

Block Diagram

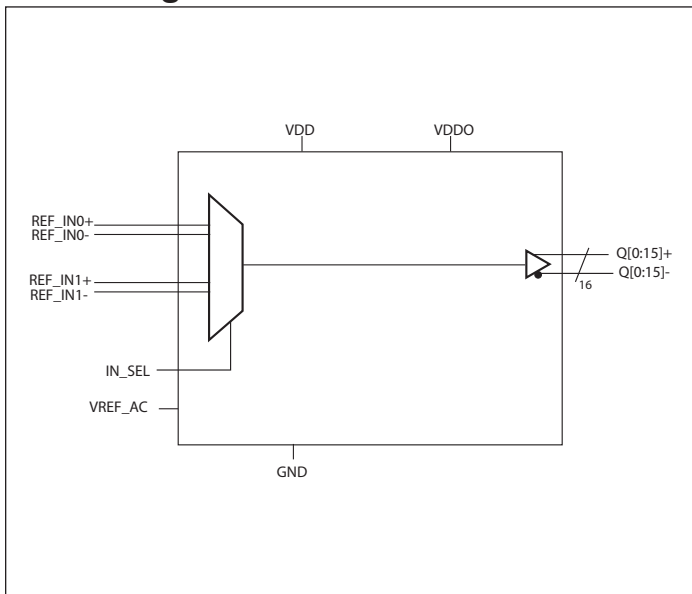

Pin Configuration (48-Pin TQFN)

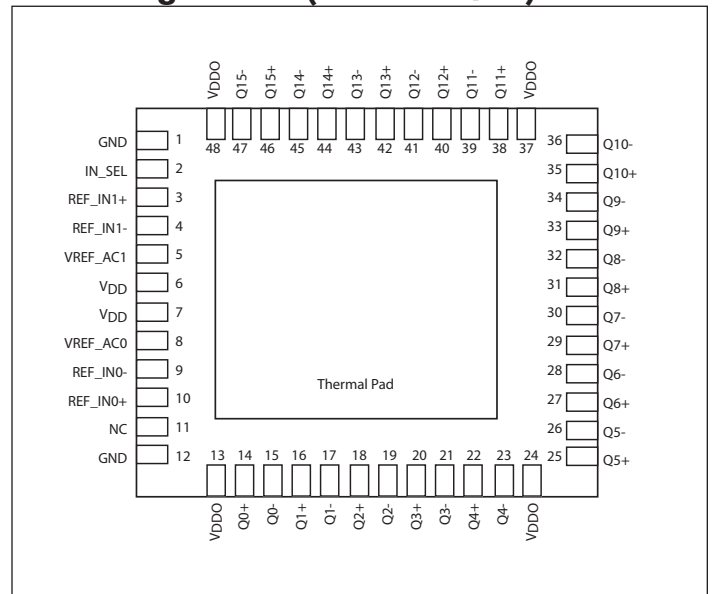

Pin Description

Pin #	Pin Name	Type	Description
1, 12	GND	Power	Power supply ground
2	IN_SEL	Input	Input clock select. See Table 1 for function. LVCMOS/LVTTL interface levels.
3, 4	REF_IN1+	Input	Reference input 1. Accepts Differential or Single Ended inputs
	REF_IN1-		
5	VREF_AC1	Output	Bias voltage output for REF_IN1
6, 7	VDD	Power	Core power supply
8	VREF_AC0	Output	Bias voltage output for REF_IN0
9, 10	REF_IN0+	Input	Reference input 0. Accepts Differential or Single Ended inputs
	REF_IN0-		
11	NC	-	No Connect
13, 24, 37, 48	VDDO	Power	Output power supply
14, 15	Q0+	Output	LVDS output pair 0.
	Q0-		
16, 17	Q1+	Output	LVDS output pair 1.
	Q1-		
18, 19	Q2+	Output	LVDS output pair 2.
	Q2-		
20, 21	Q3+	Output	LVDS output pair 3.
	Q3-		
22, 23	Q4+	Output	LVDS output pair 4.
	Q4-		
25, 26	Q5+	Output	LVDS output pair 5.
	Q5-		
27, 28	Q6+	Output	LVDS output pair 6.
	Q6-		
29, 30	Q7+	Output	LVDS output pair 7.
	Q7-		
31, 32	Q8+	Output	LVDS output pair 8.
	Q8-		
33, 34	Q9+	Output	LVDS output pair 9.
	Q9-		
35, 36	Q10+	Output	LVDS output pair 10.
	Q10-		

PI6C5921516

Pin Description Cont.

Pin #	Pin Name	Type	Description
38, 39	Q11+	Output	LVDS output pair 11.
	Q11-		
40, 41	Q12+	Output	LVDS output pair 12.
	Q12-		
42, 43	Q13+	Output	LVDS output pair 13.
	Q13-		
44, 45	Q14+	Output	LVDS output pair 14.
	Q14-		
46, 47	Q15+	Output	LVDS output pair 15.
	Q15-		
Thermal pad	-	-	Thermal pad. Connect to ground.

Function Table

Table 1: Input select function

IN_SEL	Function
0	REF_IN0 is the selected reference input
1	REF_IN1 is the selected reference input
Open	No inputs selected. Outputs Hi-Z

Symbol	Parameter	Test Condition	Min.	Typ.	Max.	Units
C _{IN}	Input Capacitance			2		pF
R _{PULLDOWN}	Input Pulldown Resistor			200		kΩ
R _{PULLUP}	Input Pullup Resistor			200		kΩ

Maximum Ratings (Above which the useful life may be impaired. For user guidelines, not tested)

Storage temperature.....	-55 to +150°C
Supply Voltage to Ground Potential (V_{DD} , V_{DDO})...	-0.5 to +4.6V
Inputs (Referenced to GND)	-0.5 to $V_{DD}+0.5V$
Clock Output (Referenced to GND).....	-0.5 to $V_{DD}+0.5V$
Latch up	200mA
ESD Protection (Input)	2000 V min (HBM)
ESD Protection (Input)	1000 V min (CDM)

Note:

Stresses greater than those listed under MAXIMUM RATINGS may cause permanent damage to the device. This is a stress rating only and functional operation of the device at these or any other conditions above those indicated in the operational sections of this specification is not implied. Exposure to absolute maximum rating conditions for extended periods may affect reliability.

Power Supply Characteristics and Operating Conditions

Symbol	Parameter	Test Condition	Min.	Typ.	Max.	Units
V_{DD}	Core Supply Voltage		3.135	3.3	3.465	V
			2.375	2.5	2.625	V
V_{DDO}	Output Supply Voltage		3.135	3.3	3.465	V
			2.375	2.5	2.625	V
I_{DD}	Core Power Supply Current			190	235	mA
I_{DDO}	Output Power Supply Current	All LVDS outputs loaded				
T_A	Ambient Operating Temperature		-40		85	°C

DC Electrical Specifications - Differential Inputs

Symbol	Parameter	Test Condition	Min.	Typ.	Max.	Units
I_{IH}	Input High current	Input = V_{DD}			20	uA
I_{IL}	Input Low current	Input = GND	-20			uA
V_{IH}	Input high voltage				$V_{DD}+0.3$	V
V_{IL}	Input low voltage		-0.3			V
V_{ID}	Input Differential Amplitude PK-PK		0.1			V
V_{CM}	Common mode input voltage		GND + 0.5		$V_{DD}-0.85$	V
ISO_{MUX}	MUX isolation			-89		dBc

DC Electrical Specifications - LVCMOS Inputs

Symbol	Parameter	Conditions	Min.	Typ.	Max.	Units
I_{IH}	Input High current	Input = V_{DD}			150	μA
I_{IL}	Input Low current	Input = GND	-150			μA
V_{IH}	Input high voltage	$V_{DD}=3.3V$	2.0		$V_{DD}+0.3$	V
		$V_{DD}=2.5V$	1.7		$V_{DD}+0.3$	V
V_{IL}	Input low voltage	$V_{DD}=3.3V$	-0.3		0.8	V
		$V_{DD}=2.5V$	-0.3		0.7	V

DC Electrical Specifications- LVDS Outputs

Parameter	Description	Conditions	Min.	Typ.	Max.	Units
V_{OH}	Output High voltage			1.4		V
V_{OL}	Output Low voltage			1.0		V
V_{OD}	Differential output voltage	@800MHz to $\leq 1.5GHz$	100		400	mV
		@ $\leq 800MHz$	250		450	mV
DV_{OD}	Change in V_{OD} between completely output states		-15		15	mV
V_{ocm}	Output commode voltage			1.25		V
DV_{ocm}	Change in V_{ocm} between completely output states				50	mV

AC Electrical Specifications – Differential Inputs

Parameter	Description	Conditions	Min.	Typ.	Max.	Units
F_{IN}	Clock input frequency				1500	MHz
V_{INPP}	Differential Input peak to peak voltage	$1.5GHz \leq F_{IN} \leq 2 GHz$	0.2		1.5	V
		$F_{IN} \leq 1.5 GHz$	0.1		1.5	V
ER	Input Edge Rate		1.5			V/ns

AC Electrical Specifications – LVCMOS Inputs

Parameter	Description	Conditions	Min.	Typ.	Max.	Units
F _{IN}	Clock input frequency				200	MHz
ER	Input Edge Rate		1.5			V/ns

AC Electrical Specifications – LVDS Outputs

Parameter	Description	Conditions	Min.	Typ.	Max.	Units
F _{OUT}	Clock output frequency	LVDS			1500	MHz
T _r	Output rise time	From 20% to 80%		150		ps
T _f	Output fall time	From 80% to 20%		150		ps
T _{ODC}	Output duty cycle	<1.5GHz	48		52	%
T _j	Buffer additive jitter RMS	156.25MHz, 12kHz to 20MHz		0.01		ps
		156.25MHz, 10kHz to 1MHz		0.01		ps
T _{SK}	Output Skew			40	50	ps
T _{PD}	Propagation Delay			620	700	ps
T _{OD}	Valid to HiZ				100	ns
T _{OE}	HiZ to valid				100	ns
T _{P2P Skew}	Part to Part Skew ¹		-50		50	ps
V _{REF_AC}	Input bias voltage	I _{AC} = 2mA		1.25		V

Propagation Delay

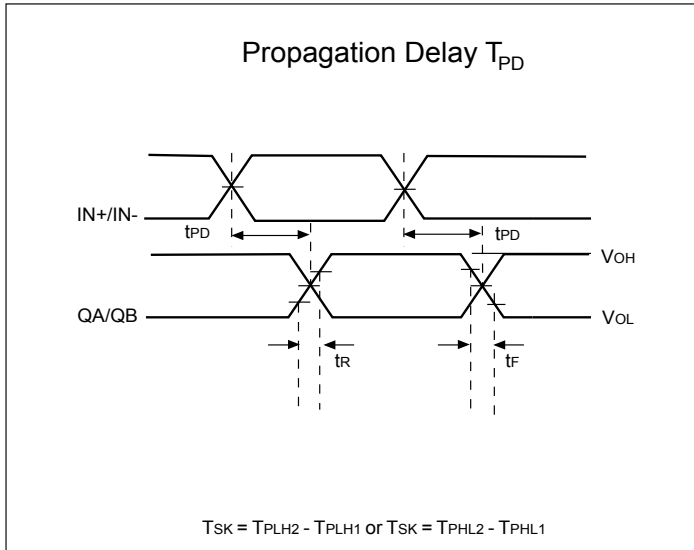

Output Skew

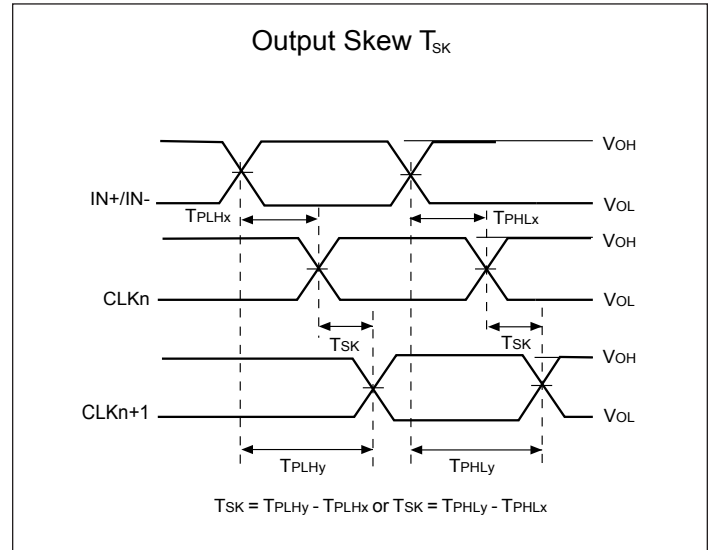

Part to Part Skew

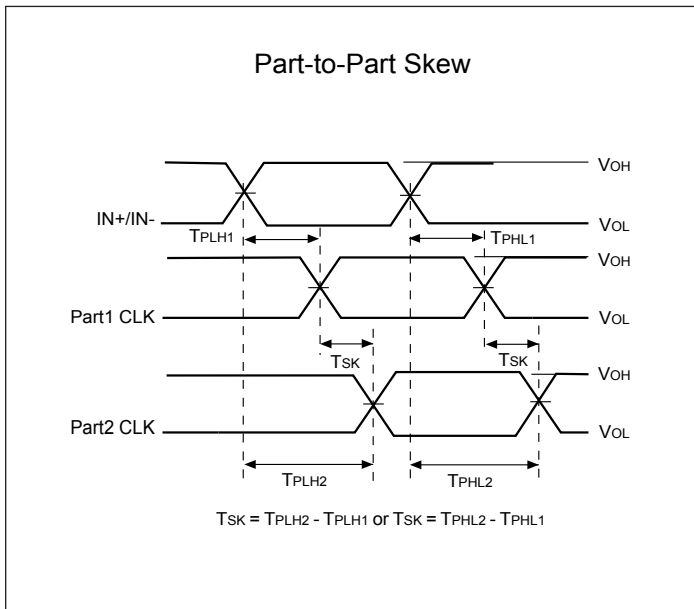

LVDS Output Swing vs. Frequency

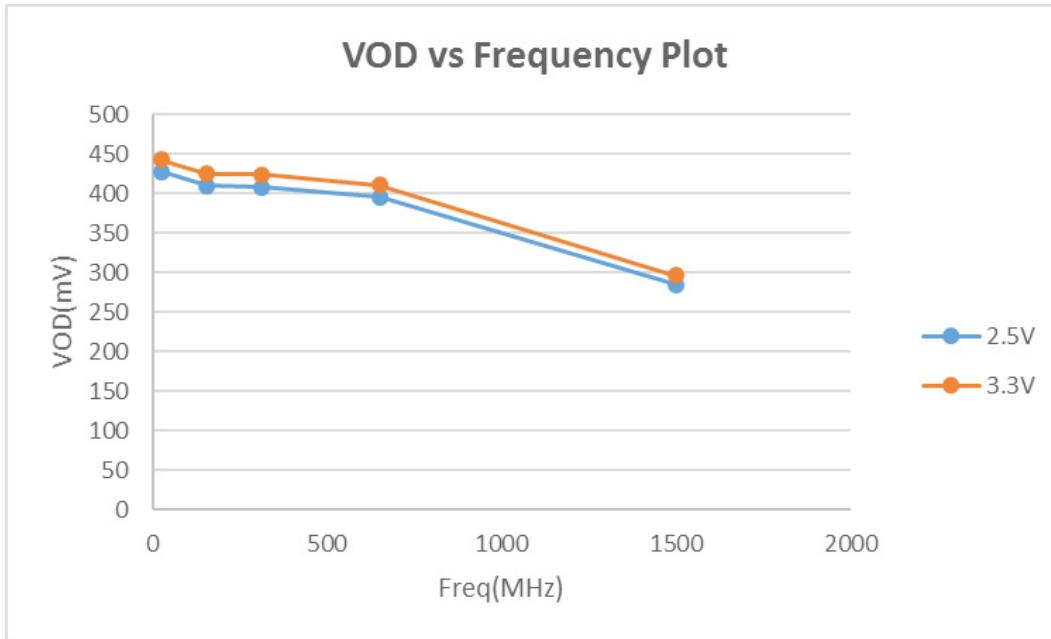

Phase Noise and Additive Jitter

$$\text{Additive jitter} = \sqrt{(\text{Output jitter}^2 - \text{Input jitter}^2)}$$

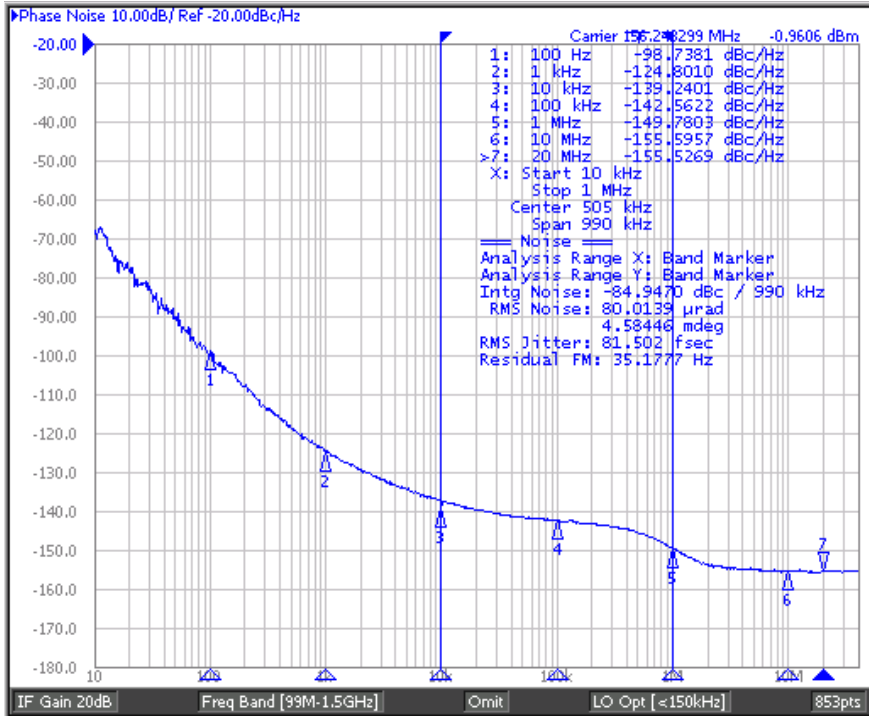

Configuration Test Load Board Termination for LVDS/ LVDS Outputs

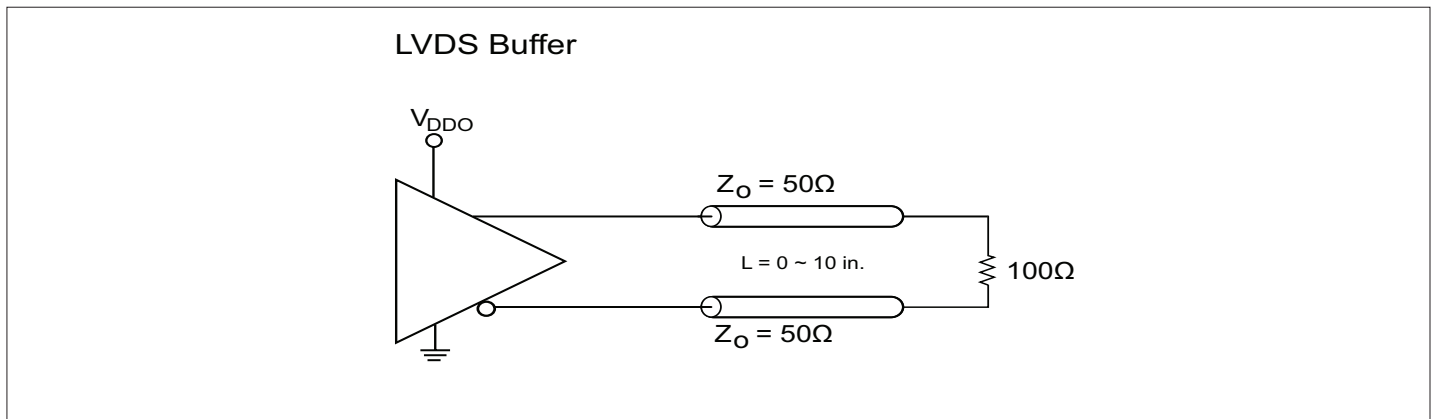

Application Information

Wiring the differential input to accept single ended levels

Figure 1 shows how the differential input can be wired to accept single ended levels. The reference voltage $V_{REF} = V_{DD}/2$ is generated by the bias resistors R1, R2 and C1. This bias circuit should be located as close as possible to the input pin. The ratio of R1 and R2 might need to be adjusted to position the V_{REF} in the center of the input voltage swing. For example, if the input clock swing is only 2.5V and $V_{DD} = 3.3V$, V_{REF} should be 1.25V and $R1/R2 = 0.609$.

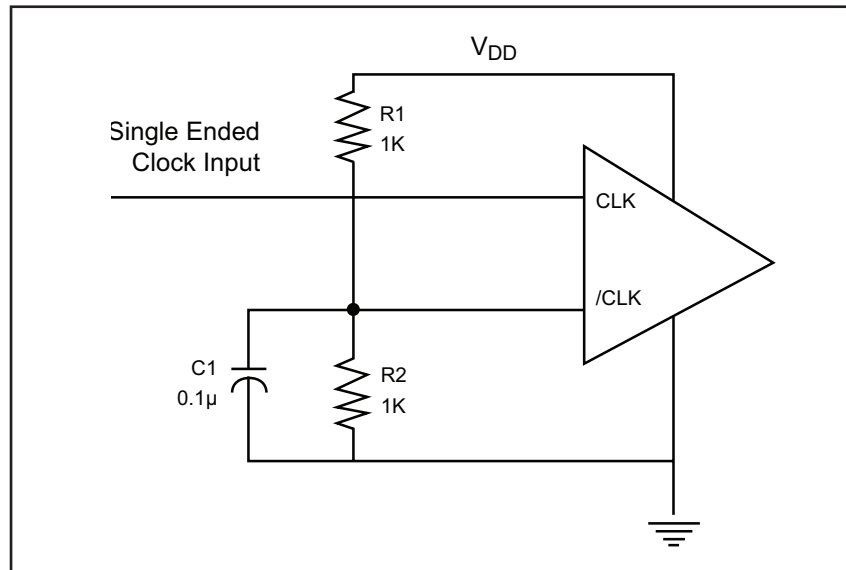
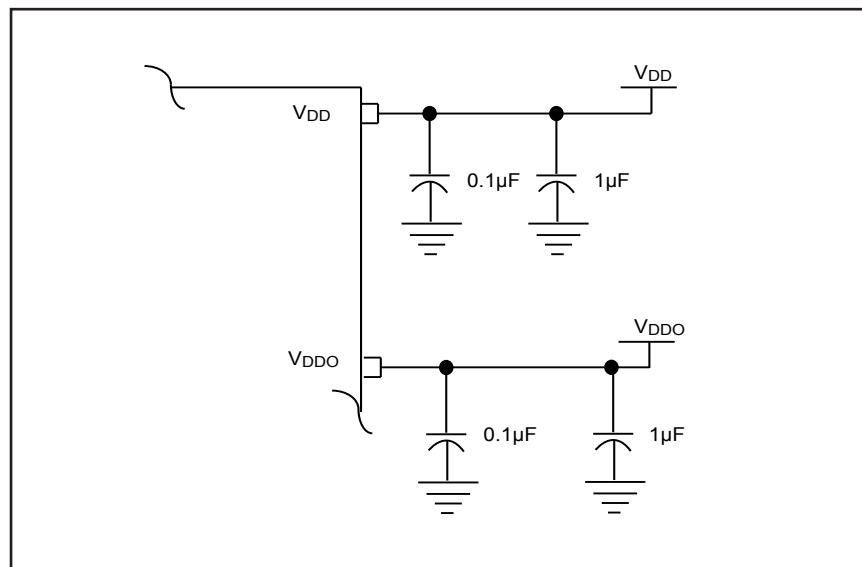

Figure 1. Single-ended input to Differential input device

Power Supply Filtering Techniques

As in any high speed analog circuitry, the power supply pins are vulnerable to random noise. To achieve optimum jitter performance, power supply isolation is required. All power pins should be individually connected to the power supply plane through vias, and 0.1µF and 1µF bypass capacitors should be used for each pin.



Single Ended Input, DC couple

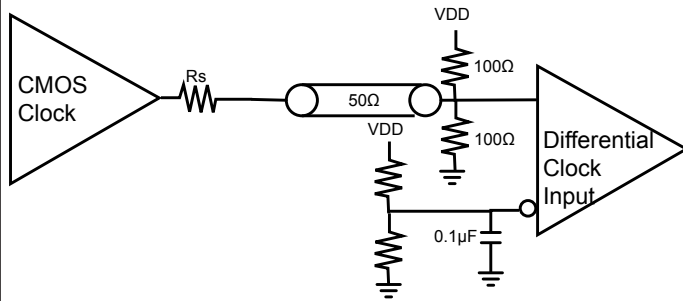

LVDS, AC Couple, Thevenin Equivalent

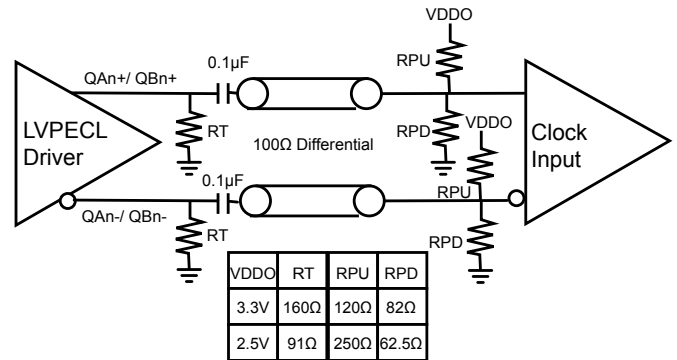

LVDS, DC Couple, Thevenin Equivalent

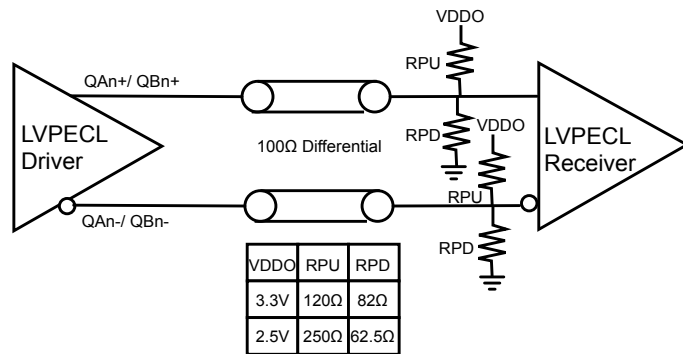

LVDS DC Couple

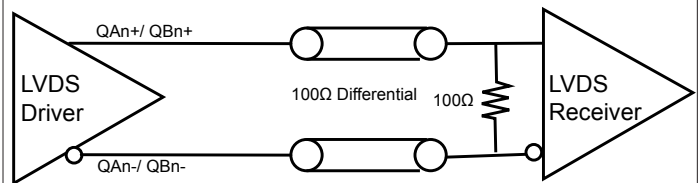

LVDS AC Couple at Load

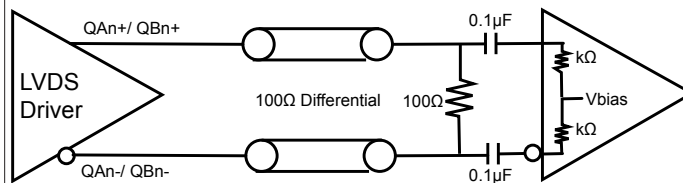

LVDS AC Couple with Internal Termination

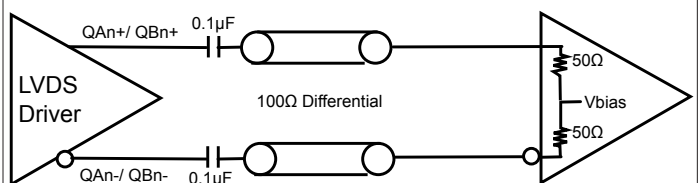

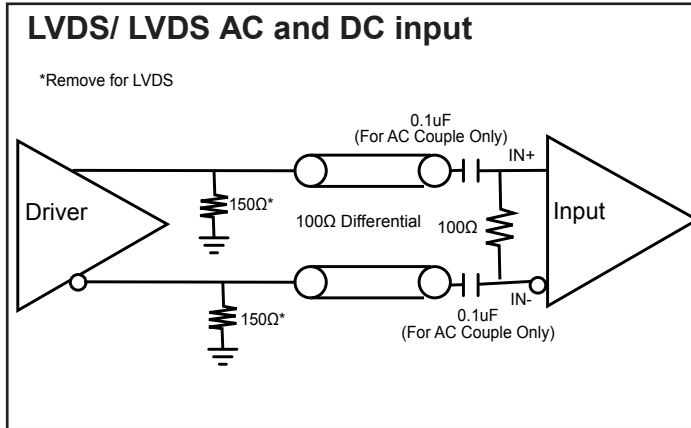

Thermal Information

Symbol	Description	Condition	
Θ_{JA}	Junction-to-ambient thermal resistance	Still air	23.65 °C/W
Θ_{JC}	Junction-to-case thermal resistance		9.10 °C/W

Part Marking

Top mark not available at this time. To obtain advance information regarding the top mark, please contact your local sales representative.

Packaging Mechanical: 48-TQFN (ZD)

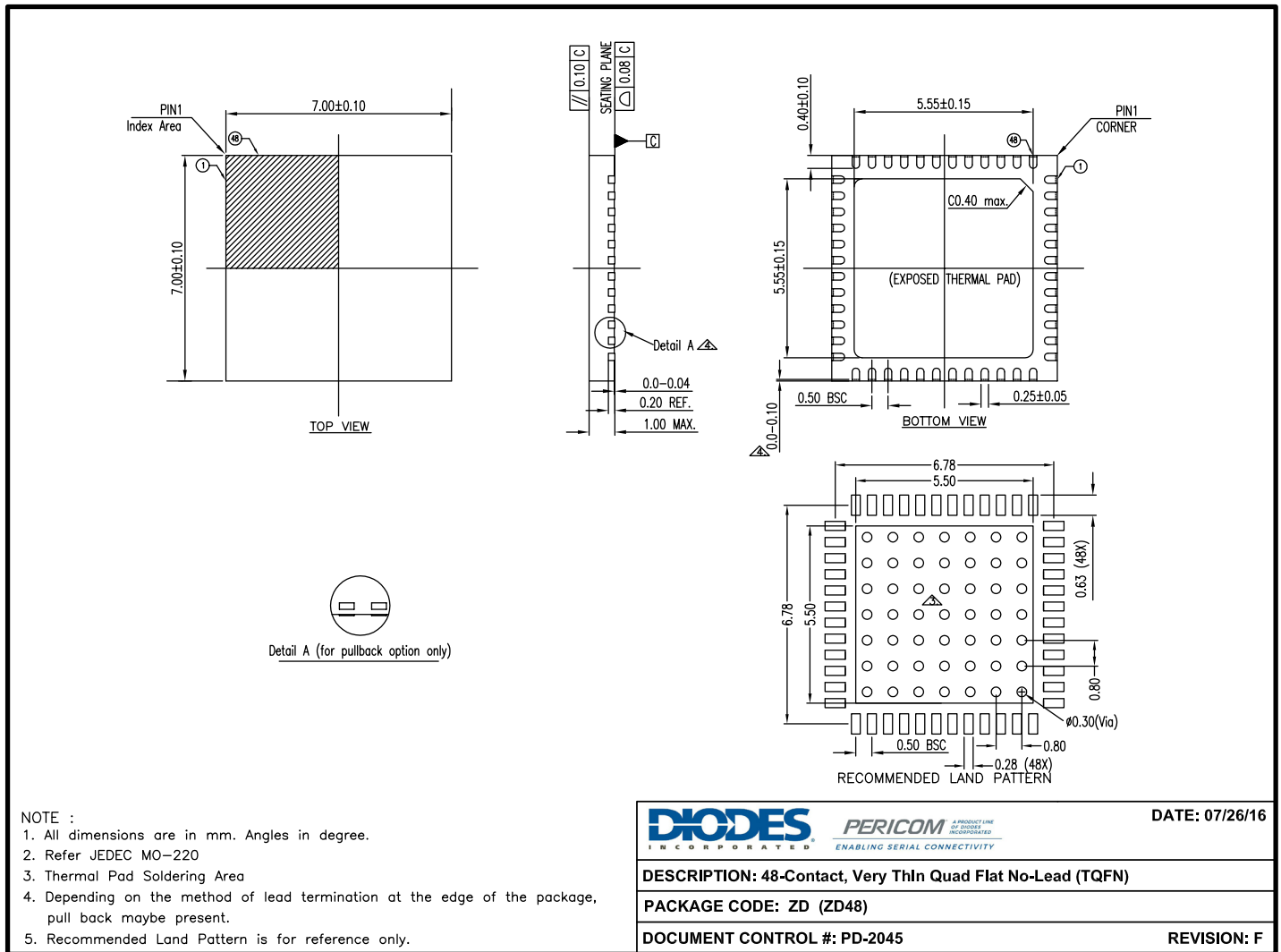

DIODES INCORPORATED	PERICOM ENABLING SERIAL CONNECTIVITY	DATE: 07/26/16
DESCRIPTION: 48-Contact, Very Thin Quad Flat No-Lead (TQFN)		
PACKAGE CODE: ZD (ZD48)		
DOCUMENT CONTROL #: PD-2045		REVISION: F

16-0151

For latest package info.

please check: <http://www.diodes.com/design/support/packaging/pericom-packaging/packaging-mechanicals-and-thermal-characteristics/>

Ordering Information

Ordering Code	Package Code	Package Description	Operating Temperature
PI6C5921516ZDIEX	ZD	48-contact, Very Thin Quad Flat No-Lead (TQFN)	-40 °C to 85 °C

Notes:

- No purposely added lead. Fully EU Directive 2002/95/EC (RoHS), 2011/65/EU (RoHS 2) & 2015/863/EU (RoHS 3) compliant.
- See <http://www.diodes.com/quality/lead-free/> for more information about Diodes Incorporated's definitions of Halogen- and Antimony-free, "Green" and Lead-free. Thermal characteristics can be found on the company web site at www.diodes.com/design/support/packaging/
- E = Pb-free and Green
- X suffix = Tape/Reel

IMPORTANT NOTICE

DIODES INCORPORATED MAKES NO WARRANTY OF ANY KIND, EXPRESS OR IMPLIED, WITH REGARDS TO THIS DOCUMENT, INCLUDING, BUT NOT LIMITED TO, THE IMPLIED WARRANTIES OF MERCHANTABILITY AND FITNESS FOR A PARTICULAR PURPOSE (AND THEIR EQUIVALENTS UNDER THE LAWS OF ANY JURISDICTION).

Diodes Incorporated and its subsidiaries reserve the right to make modifications, enhancements, improvements, corrections or other changes without further notice to this document and any product described herein. Diodes Incorporated does not assume any liability arising out of the application or use of this document or any product described herein; neither does Diodes Incorporated convey any license under its patent or trademark rights, nor the rights of others. Any Customer or user of this document or products described herein in such applications shall assume all risks of such use and will agree to hold Diodes Incorporated and all the companies whose products are represented on Diodes Incorporated website, harmless against all damages.

Diodes Incorporated does not warrant or accept any liability whatsoever in respect of any products purchased through unauthorized sales channel.

Should Customers purchase or use Diodes Incorporated products for any unintended or unauthorized application, Customers shall indemnify and hold Diodes Incorporated and its representatives harmless against all claims, damages, expenses, and attorney fees arising out of, directly or indirectly, any claim of personal injury or death associated with such unintended or unauthorized application.

Products described herein may be covered by one or more United States, international or foreign patents pending. Product names and markings noted herein may also be covered by one or more United States, international or foreign trademarks.

This document is written in English but may be translated into multiple languages for reference. Only the English version of this document is the final and definitive format released by Diodes Incorporated.

LIFE SUPPORT

Diodes Incorporated products are specifically not authorized for use as critical components in life support devices or systems without the express written approval of the Chief Executive Officer of Diodes Incorporated. As used herein:

A. Life support devices or systems are devices or systems which:

1. are intended to implant into the body, or

2. support or sustain life and whose failure to perform when properly used in accordance with instructions for use provided in the labeling can be reasonably expected to result in significant injury to the user.

B. A critical component is any component in a life support device or system whose failure to perform can be reasonably expected to cause the failure of the life support device or to affect its safety or effectiveness.

Customers represent that they have all necessary expertise in the safety and regulatory ramifications of their life support devices or systems, and acknowledge and agree that they are solely responsible for all legal, regulatory and safety-related requirements concerning their products and any use of Diodes Incorporated products in such safety-critical, life support devices or systems, notwithstanding any devices- or systems-related information or support that may be provided by Diodes Incorporated. Further, Customers must fully indemnify Diodes Incorporated and its representatives against any damages arising out of the use of Diodes Incorporated products in such safety-critical, life support devices or systems.

Copyright © 2016, Diodes Incorporated

www.diodes.com

Looking for pricing, stock, or lifecycle information?

Click below to explore more details on WIN SOURCE:

 [View PI6C5921516ZDIEX on WIN SOURCE](#)

 [Diodes Incorporated](#) Information

Optimize Your Supply Chain with WIN SOURCE Solutions

-  Global Sourcing Solution
-  Obsolete Management
-  Cost Control Management
-  Shortage Management
-  Alternative Solution
-  Excess Inventory Management