



**THE DATASHEET OF
PI5A4157ZUEX**



Low Voltage SPDT 0.8Ω Analog Switch

Features

- CMOS Technology for Bus and Analog Applications
- Low On-Resistance: 0.8Ω at 3.0V
- Wide V_{CC} Range: 1.65V to 5.5V
- Rail-to-Rail Signal Range
- Control Input Overvoltage Tolerance: 5.5V(Min)
- Fast Transition Speed: 12ns at 5.0V
- High Bandwidth: 150 MHz
- Extended Industrial Temperature Range: -40 °C to 85 °C
- Packaging (Pb-free & Green):
 - 6-pin SOT23
 - 6-pin SC70
 - 6-Pin UDFN 1mm×1mm

Applications

- Cell Phones
- PDAs
- Portable Instrumentation
- Battery powered Communications
- Computer Peripherals

Description

The PI5A4157 is a high-bandwidth, fast single-pole double-throw (SPDT) CMOS switch. It can be used as an analog switch or as a low-delay bus switch. The device features ultra low RON of 0.8Ω typical at 3.0V VCC and will operate over the wide VCC range of 1.65V to 5.5V.

The PI5A4157 features very low quiescent current even when the control voltage is lower than the VCC supply. This feature services the mobile handset applications very well by allowing direct interface with baseband processor general purpose I/Os.

Break-before-make switching prevents both switches being enabled simultaneously. This eliminates signal disruption during switching.

The control input, S, is independent of supply voltage.

Pin Assignment

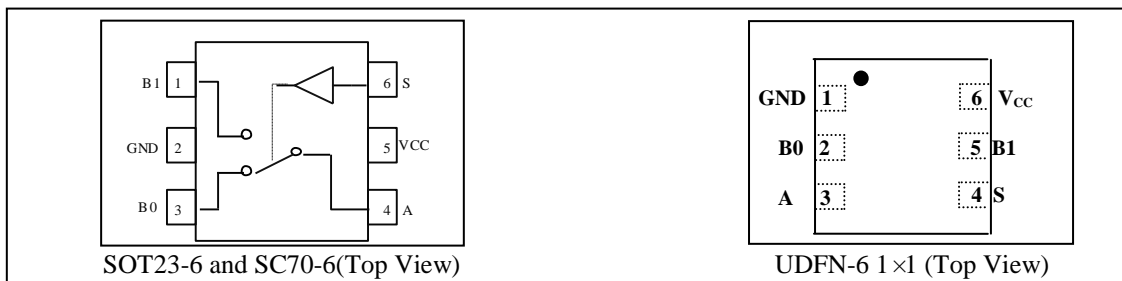

Pin Description

Pin No		Pin Name	Description
SOT23-6 SC70-6	UDFN-6 1x1		
1	5	B1	Data Port
2	1	GND	Ground
3	2	B0	Data Port (Normally connected)
4	3	A	Common Output/Data Port
5	6	V _{CC}	Positive Power Supply
6	4	S	Logic control

Logic Function Table

Logic Inputs(S)	Function
0	B ₀ connect to A
1	B ₁ connect to A

Maximum Ratings

Storage Temperature.....	-65°C to +150°C
Ambient Temperature with Power Applied.....	-40°C to +85°C
Supply Voltage V _{CC}	-0.5V to +7.0V
DC Switch Voltage V _S	-0.5V to V _{CC} +0.5V
DC Input Voltage V _{IN}	-0.5V to +7.0V
DC Output Current V _{OUT}	128mA
DC V _{CC} or Ground Current I _{CC} /I _{GND}	±100mA
Junction Temperature under Bias (T _J)	150 °C
Junction Lead Temperature (T _L) (Soldering, 10 seconds)	260 °C
ESD (HBM)	5KV
Power Dissipation (PD) @ +85 °C	SOT23 250mW SC70 200mW UDFN1x1 150mW

Note:

Stresses greater than those listed under MAXIMUM RATINGS may cause permanent damage to the device. This is a stress rating only and functional operation of the device at these or any other conditions above those indicated in the operational sections of this specification is not implied. Exposure to absolute maximum rating conditions for extended periods may affect reliability.

Recommended Operating Conditions

Symbol	Parameter	Conditions	Min.	Typ.	Max.	Unit
V _{CC}	Operating Voltage	-	1.65	-	5.5	V
V _{IN}	Control Input Voltage	-	0	-	V _{CC}	V
V _S	Switch Input Voltage	-	0	-	V _{CC}	V
V _{OUT}	Output Voltage	-	0	-	V _{CC}	V
T _A	Operating Temperature	-	-40	25	85	°C
t _r , t _f	Input Rise and Fall Time	Control Input V _{CC} = 2.7V to 3.6V	0	-	10	ns/V
		Control Input V _{CC} = 4.5V to 5.5V	0	-	5	ns/V

Note: Control input must be held HIGH or LOW; it must not float.

DC Electrical Characteristics

($T_A = -40\text{ }^\circ\text{C}$ to $85\text{ }^\circ\text{C}$, unless otherwise noted.)

Parameter	Description	Test Conditions	Supply Voltage	Min	Typ	Max	Units
V_{IAR}	Analog Input Signal Range	-	V_{CC}	0	-	V_{CC}	V
R_{ON}	ON Resistance ⁽¹⁾	$I_O = 100\text{mA}$, $V_{IN} = 0\text{V}$	4.5V	-	0.7	1.1	Ω
		$I_O = 100\text{mA}$, $V_{IN} = 2.4\text{V}$		-	0.6	1.0	
		$I_O = 100\text{mA}$, $V_{IN} = 4.5\text{V}$		-	0.8	1.2	
		$I_O = 100\text{mA}$, $V_{IN} = 0\text{V}$	3.0V	-	0.8	1.3	
		$I_O = 100\text{mA}$, $V_{IN} = 3.0\text{V}$		-	0.9	1.9	
		$I_O = 100\text{mA}$, $V_{IN} = 0\text{V}$	2.3V	-	1.0	1.5	
		$I_O = 100\text{mA}$, $V_{IN} = 2.3\text{V}$		-	1.2	1.8	
		$I_O = 100\text{mA}$, $V_{IN} = 0\text{V}$	1.65V	-	1.3	1.9	
$I_O = 100\text{mA}$, $V_{IN} = 1.65\text{V}$	-	2.0		2.8			
ΔR_{ON}	ON Resistance Match Between Channels ^(1,2,3)	$I_A = 100\text{mA}$, $V_{Bn} = 3.15\text{V}$	4.5V	-	0.01	0.03	Ω
		$I_A = 100\text{mA}$, $V_{Bn} = 2.1\text{V}$	3.0V	-	0.02	0.04	
		$I_A = 100\text{mA}$, $V_{Bn} = 1.6\text{V}$	2.3V	-	0.03	0.06	
		$I_A = 100\text{mA}$, $V_{Bn} = 1.15\text{V}$	1.65V	-	0.03	0.06	
R_{ONF}	ON Resistance Flatness ^(1,2,4)	$I_A = 100\text{mA}$, $V_{Bn} = 0\text{V}, 2.4\text{V}, 4.5\text{V}$	4.5V	-	0.2	0.4	Ω
		$I_A = 100\text{mA}$, $V_{Bn} = 0\text{V}, 1.5\text{V}, 3.3\text{V}$	3.3V	-	0.2		
		$I_A = 100\text{mA}$, $V_{Bn} = 0\text{V}, 1.1\text{V}, 2.5\text{V}$	2.5V	-	0.4	0.6	
		$I_A = 100\text{mA}$, $V_{Bn} = 0\text{V}, 0.7\text{V}, 1.8\text{V}$	1.8V	-	1.0	1.4	
V_{IH}	Input High Voltage	Logic High Level	$V_{CC} = 1.65\text{V}$	0.9	-	-	V
			$V_{CC} = 2.3\text{V}$	1.0	-	-	
			$V_{CC} = 3\text{V}$	1.1	-	-	
			$V_{CC} = 4.2\text{V}$	1.2	-	-	
			$V_{CC} = 5.5\text{V}$	1.3	-	-	
V_{IL}	Input Low Voltage	Logic Low Level	$V_{CC} = 1.65\text{V}$	-	-	0.6	V
			$V_{CC} = 2.3\text{V}$	-	-	0.6	
			$V_{CC} = 3\text{V}$	-	-	0.6	
			$V_{CC} = 4.2\text{V}$	-	-	0.8	
			$V_{CC} = 5.5\text{V}$	-	-	0.8	
$I_{OFF(NO)}$ or $I_{OFF(NC)}$	Source Off Leakage Current	$V_{CC} = 5.5\text{V}$, $V_A = 1\text{V}$, 4.5V $V_{Bn} = 1\text{V}$, 4.5V	$V_{CC} = 3\text{V}$	-20	-	+20	nA
$I_{INC(ON)}$, $I_{NO(ON)}$, $I_{COM(ON)}$	Channel On Leakage Current	-	$V_{CC} = 1.65$ to 5.5V	-40	-	+40	
I_{CC}	Quiescent Supply Current	All channels ON or OFF, $V_{IN} = V_{CC}$ or GND, $I_{OUT} = 0$	$V_{CC} = 3.6\text{V}$	-	0.002	0.1	μA
			$V_{CC} = 5.5\text{V}$	-	0.002	0.1	
I_{CCT}	Increase in I_{CC} per Input	Input at 2.7V	$V_{CC} = 4.3\text{V}$	-	0.2	10.0	μA

Notes:

1. Measured by voltage drop between A and B pins at the indicated current through the device. ON resistance is determined by the lower of the voltages on two ports (A or B).
2. Parameter is characterized but not tested in production.
3. $\Delta R_{ON} = R_{ON\text{ max}} - R_{ON\text{ min}}$. measured at identical V_{CC} , temperature and voltage levels.
4. Flatness is defined as difference between maximum and minimum value of ON resistance over the specified range of conditions.

Capacitance ⁽¹⁾

Symbol	Parameter	Test Conditions	Min	Typ	Max	Units
C_{IN}	Control Input	$V_{CC} = 5.0V, f = 1 \text{ MHz}, T_A = 25^\circ C$	-	3.5	-	pF
C_{IO-B}	For B Port, Switch OFF		-	15.0	-	
C_{IOA-ON}	For A Port, Switch ON		-	34.0	-	

Notes:

1. Capacitance is characterized but not tested in production

Switch and AC Characteristics ⁽¹⁾

Parameter	Description	Test Conditions	Supply Voltage	Min	Typ	Max	Units
t_{BBM}	Break Before Make Time	See Figure 2	$V_{CC} = 2.7V \text{ to } 3.6V$	-	10	20	ns
			$V_{CC} = 4.5V \text{ to } 5.5V$	-	6	12	
t_{ON}	Turn on Time	See Figure 1	$V_{CC} = 2.7V \text{ to } 3.6V$	-	12	25	
			$V_{CC} = 4.5V \text{ to } 5.5V$	-	9	18	
t_{OFF}	Turn off Time	See Figure 1	$V_{CC} = 2.7V \text{ to } 3.6V$	-	17	35	
			$V_{CC} = 4.5V \text{ to } 5.5V$	-	10	20	
Q	Charge Injection	$C_L = 1nF, V_{GEN} = 0V,$ $R_{GEN} = 0\Omega.$ See Figure 3	$V_{CC} = 5.0V$	-	35	-	pC
			$V_{CC} = 3.3V$	-	25	-	
OIRR	Off Isolation	$R_L = 50\Omega, V_{GEN} = 0V,$ $R_{GEN} = 0\Omega, f = 1MHz.$ See Figure 4 ⁽²⁾	$V_{CC} = 1.65V \text{ to } 5.5V$	-	-70	-	dB
X_{TALK}	Crosstalk Isolation	$f = 1MHz,$ See Figure 5	$V_{CC} = 1.65V \text{ to } 5.5V$	-	-70	-	
f3dB	-3dB Bandwidth	See Figure 8	$V_{CC} = 1.65V \text{ to } 5.5V$	-	150	-	MHz
T_{HD}	Total Harmonic Distortion	$R_L = 600\Omega, V_{IN} = 0.5V_{pp},$ $f = 20Hz \text{ to } 20kHz$ See Figure 9	$V_{CC} = 2.7V \text{ to } 4.2V$	-	0.015	-	%

Notes:

- Guaranteed by design.
- Off Isolation = $20 \text{ Log}_{10} [V_{Bn}/V_A]$ and is measured in dB.

Test Circuits and Timing Diagrams

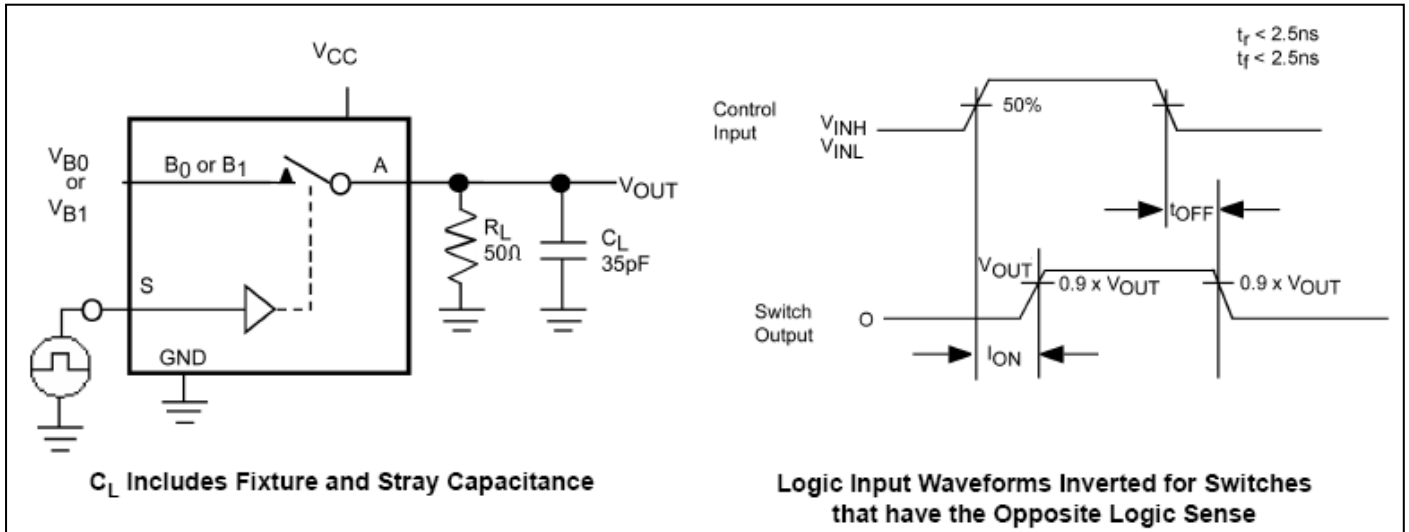

Figure 1. Turn ON/OFF Timing

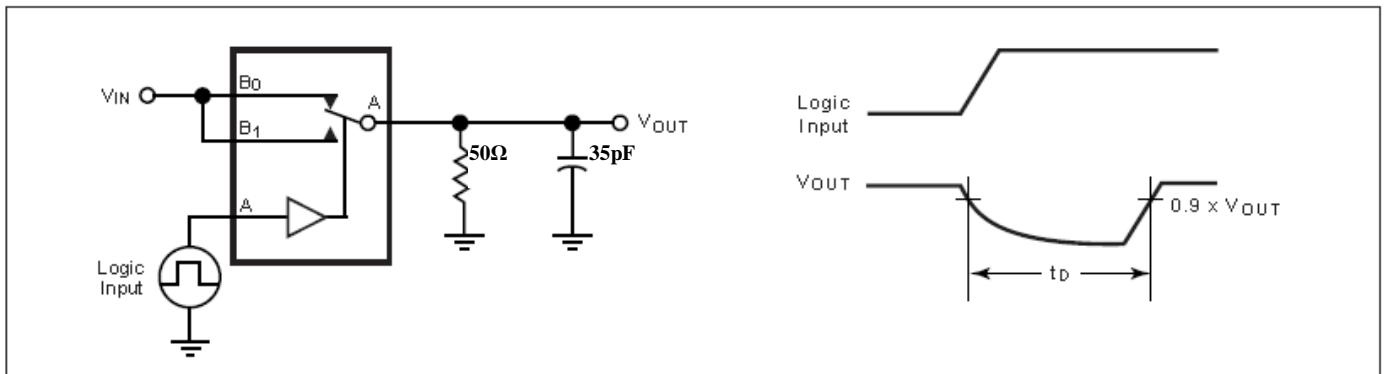

Figure 2. Break Before Make Interval Timing

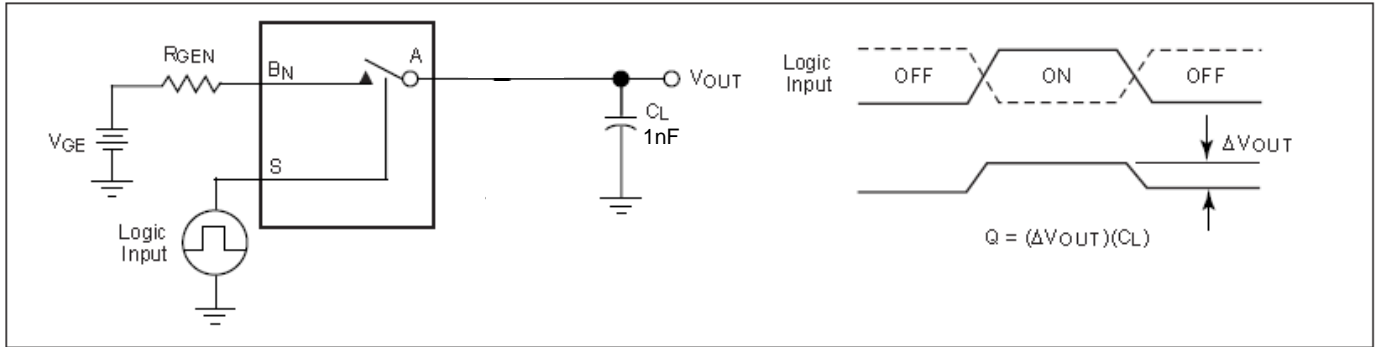

Figure 3. Charge Injection Test

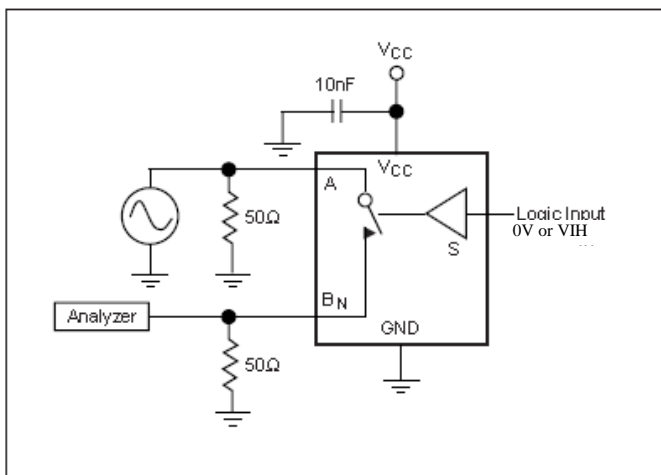

Figure 4. Off Isolation

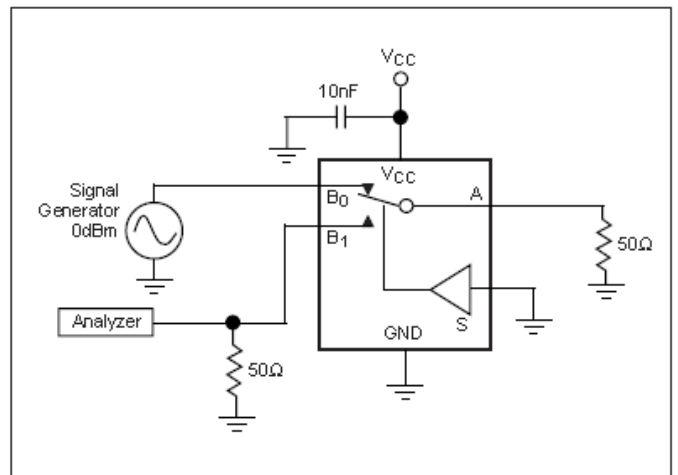

Figure 5. Crosstalk

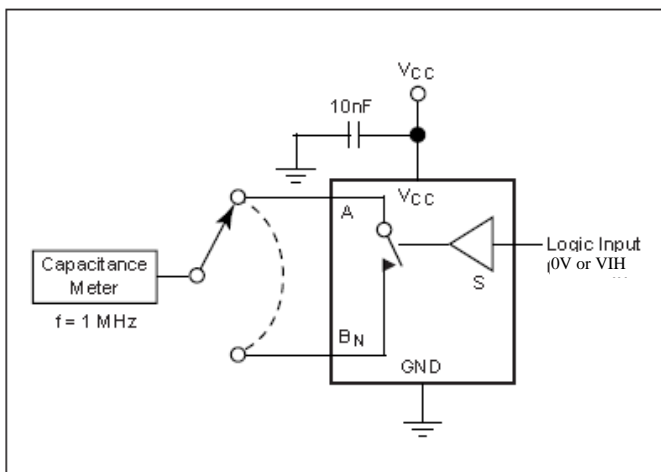

Figure 6. Channel Off Capacitance

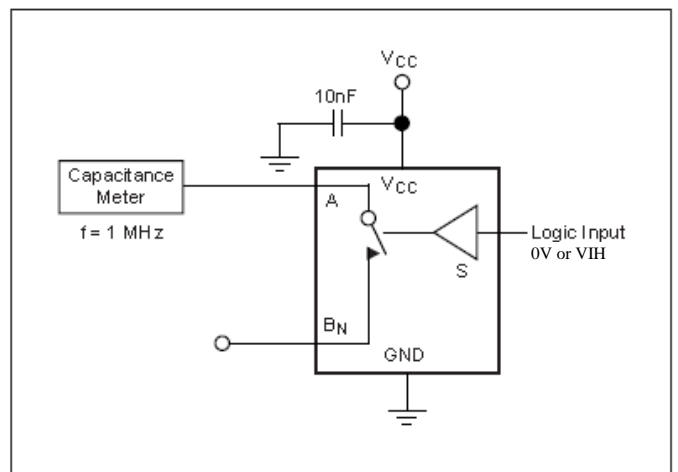

Figure 7. Channel On Capacitance

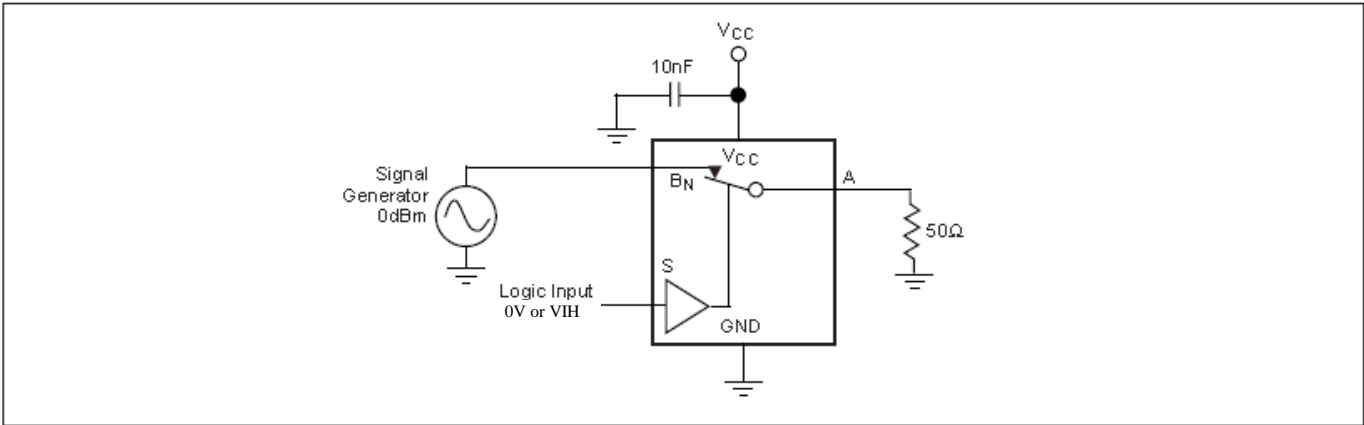

Figure 8. Bandwidth

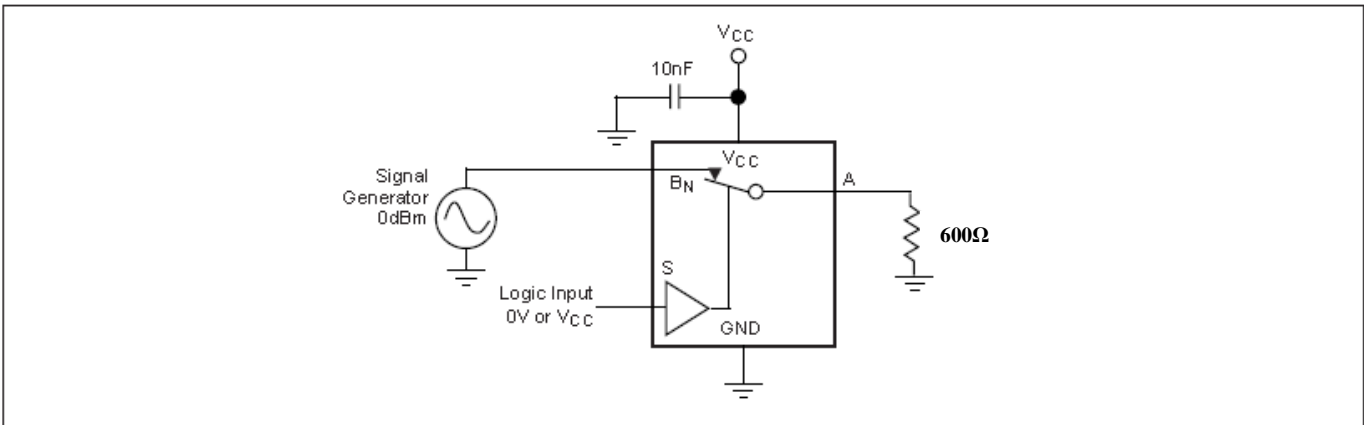

Figure 9. Harmonic Distortion

P15A4157

Mechanical Information
TA (6-pin SOT23)

PKG. DIMENSIONS(MM)		
SYMBOL	Min	Max
A	-	1.45
A1	0.00	0.15
A2	0.90	1.30
b	0.30	0.50
c	0.08	0.22
D	2.75	3.05
E	1.45	1.75
E1	2.60	3.00
e	0.95 BSC	
L	0.30	0.60
θ	0°	8°

Note:
1. Ref. JEDEC MO-178C/AB
2. PACKAGE OUTLINE DIMENSIONS DO NOT INCLUDE MOLD FLASH AND METAL BURR

<p>Enabling Serial Connectivity</p>	DATE: 03/29/16
	DESCRIPTION: 6-Pin, Small Outline Transistor Plastic Package (SOT23)
	PACKAGE CODE: TA (TA6)
	DOCUMENT CONTROL #: PD-2145
	REVISION:A

16-0082

PI5A4157

C (6-pin SC70)

PKG. DIMENSIONS(MM)		
SYMBOL	Min	Max
A	-	1.10
A1	0.00	0.10
A2	0.70	1.00
b	0.15	0.40
c	0.08	0.22
D	1.80	2.20
E	1.10	1.40
E1	1.80	2.40
e	0.65 BSC	
L	0.26	0.46
θ	0°	8°

Notes:
 1. Comply with MO-203C/AB, except b Max, D Min and D Max.
 2. PACKAGE OUTLINE DIMENSIONS DO NOT INCLUDE MOLD FLASH AND METAL BURR

PERICOM Enabling Serial Connectivity		DATE: 03/29/16
DESCRIPTION: 6-Pin, SOT363 (SC70)		
PACKAGE CODE: C (C6)		
DOCUMENT CONTROL#: PD-1902	REVISION: B	

16-0078

ZU (6-pin UDFN 1x1)

PKG. DIMENSIONS(MM)		
SYMBOL	Min	Max
A	0.50	0.60
A1	0.00	0.05
A3	0.15 REF	
D	0.95	1.05
E	0.95	1.05
b	0.10	0.20
L	0.30	0.50
e	0.35 BSC	

Note:
1. Ref. JEDEC MO-287A

		DATE: 06/18/13
DESCRIPTION: 6-Pin, UDFN, 1X1		
PACKAGE CODE: ZU (ZU6)		
DOCUMENT CONTROL #: PD-2152	REVISION: -	

13-0191

Marking Description

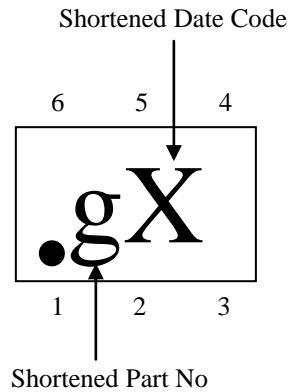

Note: For latest package info, please check: <http://www.pericom.com/products/packaging/mechanicals.php>

Ordering Information

Part Number	Package Code	Package	Top Marking
PI5A4157CEX	C	6-Pin, SOT363 (SC70), Tape & Reel	mA
PI5A4157TAEX	TA	6-Pin, Small Outline Transistor Plastic Package (SOT23), Tape & reel	mA
PI5A4157ZUEX	ZU	6-Pin, 1x1 (UDFN), Tape & reel	g

Notes:

- Thermal characteristics can be found on the company web site at www.pericom.com/packaging/
- E = Pb-free and Green
- X suffix = Tape/Reel

IMPORTANT NOTICE

DIODES INCORPORATED MAKES NO WARRANTY OF ANY KIND, EXPRESS OR IMPLIED, WITH REGARDS TO THIS DOCUMENT, INCLUDING, BUT NOT LIMITED TO, THE IMPLIED WARRANTIES OF MERCHANTABILITY AND FITNESS FOR A PARTICULAR PURPOSE (AND THEIR EQUIVALENTS UNDER THE LAWS OF ANY JURISDICTION).

Diodes Incorporated and its subsidiaries reserve the right to make modifications, enhancements, improvements, corrections or other changes without further notice to this document and any product described herein. Diodes Incorporated does not assume any liability arising out of the application or use of this document or any product described herein; neither does Diodes Incorporated convey any license under its patent or trademark rights, nor the rights of others. Any Customer or user of this document or products described herein in such applications shall assume all risks of such use and will agree to hold Diodes Incorporated and all the companies whose products are represented on Diodes Incorporated website, harmless against all damages.

Diodes Incorporated does not warrant or accept any liability whatsoever in respect of any products purchased through unauthorized sales channel.

Should Customers purchase or use Diodes Incorporated products for any unintended or unauthorized application, Customers shall indemnify and hold Diodes Incorporated and its representatives harmless against all claims, damages, expenses, and attorney fees arising out of, directly or indirectly, any claim of personal injury or death associated with such unintended or unauthorized application.

Products described herein may be covered by one or more United States, international or foreign patents pending. Product names and markings noted herein may also be covered by one or more United States, international or foreign trademarks.

This document is written in English but may be translated into multiple languages for reference. Only the English version of this document is the final and determinative format released by Diodes Incorporated.

LIFE SUPPORT

Diodes Incorporated products are specifically not authorized for use as critical components in life support devices or systems without the express written approval of the Chief Executive Officer of Diodes Incorporated. As used herein:

A. Life support devices or systems are devices or systems which:

1. are intended to implant into the body, or
2. support or sustain life and whose failure to perform when properly used in accordance with instructions for use provided in the labeling can be reasonably expected to result in significant injury to the user.

B. A critical component is any component in a life support device or system whose failure to perform can be reasonably expected to cause the failure of the life support device or to affect its safety or effectiveness.

Customers represent that they have all necessary expertise in the safety and regulatory ramifications of their life support devices or systems, and acknowledge and agree that they are solely responsible for all legal, regulatory and safety-related requirements concerning their products and any use of Diodes Incorporated products in such safety-critical, life support devices or systems, notwithstanding any devices- or systems-related information or support that may be provided by Diodes Incorporated. Further, Customers must fully indemnify Diodes Incorporated and its representatives against any damages arising out of the use of Diodes Incorporated products in such safety-critical, life support devices or systems.







Copyright © 2016, Diodes Incorporated
www.diodes.com

Looking for pricing, stock, or lifecycle information?

Click below to explore more details on WIN SOURCE:

-  [View PI5A4157ZUEX on WIN SOURCE](#)
-  [Diodes Incorporated Information](#)

Optimize Your Supply Chain with WIN SOURCE Solutions

-  Global Sourcing Solution
-  Obsolete Management
-  Cost Control Management
-  Shortage Management
-  Alternative Solution
-  Excess Inventory Management