



**THE DATASHEET OF
PI3CH1012QE**



10-Bit Bus Switch, 2-Enable High and Low 1.8V/2.5V/3.3V, High-Bandwidth, Hot Plug

Features

- Near-Zero propagation delay
- 5-ohm switches connect inputs to outputs
- High signal passing bandwidth (500 MHz)
- Beyond Rail-to-Rail switching
- 0 to 5V switching with 3.3V power supply
- 0 to 3.3V switching with 2.5V power supply
- 5V I/O tolerant with supply in OFF and ON state
- 1.8V, 2.5V and 3.3V supply voltage operation
- Hot Insertion Capable
- Industrial Operating Temperature: -40°C to +85°C
- 8kV ESD Protection (human body model)
- Latch-up Performance: >200mA per JESD17
- Packaging (Pb-free & Green available):
 - -24-pin 150-mil wide plastic QSOP (Q)

Description

The PI3CH1012 is a Low-voltage, 10-channel switch designed with fast dual enables. The switch creates no additional ground bounce noise or propagation delay. The PI3CH1012 device is very useful in switching signals that have high bandwidth (500 MHz).

Applications

- High Bandwidth Data Switching
- Hot-Docking
- Analog Signal Switching
- Differential Signal Switching

Pin Configuration

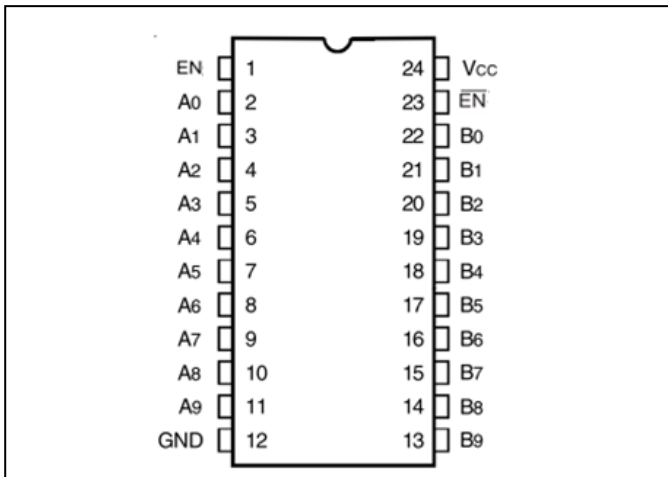

Pin Description

Pin No	Pin Name	Description
1, 23	EN, \overline{EN}	Enable
2-11	A0-A9	A Ports
13-22	B9-B0	B Ports
12	GND	Ground
24	V _{CC}	Power

Block Diagram

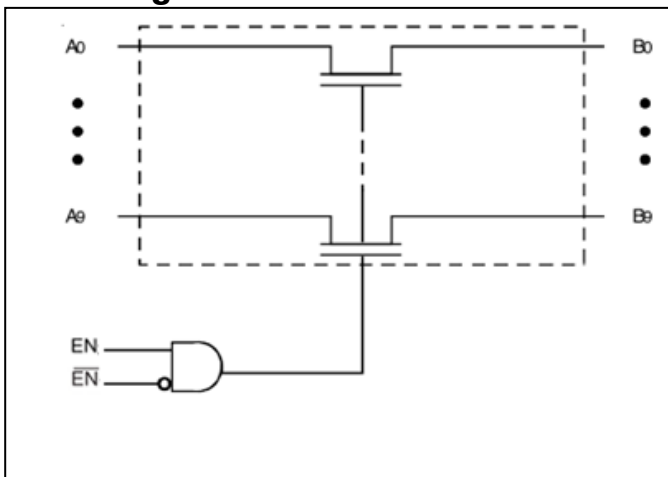

Truth Table ⁽¹⁾

A0-A9	EN	\overline{EN}	Function
Hi-Z	L	L	Disconnect
Hi-Z	L	H	Disconnect
B0-B9	H	L	Connect
Hi-Z	H	H	Disconnect

Note:

1. H=High Voltage Level; L=Low Voltage Level
Hi-Z= High Impedance.

Maximum Ratings

Storage Temperature	-65°C to +150°C
Ambient Temperature with Power Applied.....	-40°C to +85°C
Supply Voltage to Ground Potential	-0.5V to +4.6V
DC Input Voltage	-0.5V to +6.0V
DC Output Current	120mA
Power Dissipation	0.5W

Note:

Stresses greater than those listed under MAXIMUM RATINGS may cause permanent damage to the device. This is a stress rating only and functional operation of the device at these or any other conditions above those indicated in the operational sections of this specification is not implied. Exposure to absolute maximum rating conditions for extended periods may affect reliability.

DC Electrical Characteristics

3.3V supply (Over operating range, $T_A = -40 \sim +85^\circ\text{C}$, $V_{CC} = 3.3V \pm 10\%$, unless otherwise noted)

Symbol	Description	Test Conditions ⁽¹⁾	Min	Typ ⁽²⁾	Max	Unit
V_{IH}	Control Input HIGH Voltage	Guaranteed Logic HIGH Level	2.0	-	-	V
V_{IL}	Control Input LOW Voltage	Guaranteed Logic LOW Level	-0.5	-	0.8	V
V_{IK}	Clamp Diode Voltage	$V_{CC} = \text{Min.}, I_{IN} = -18\text{mA}$	-	-1.3	-1.8	V
I_{IH}	Input HIGH Current	$V_{CC} = \text{Max.}, V_{IN} = V_{CC}$	-	-	± 1	μA
I_{IL}	Input Low Current	$V_{CC} = \text{Max.}, V_{IN} = \text{GND}$	-	-	± 1	μA
I_{OZH}	High-Impedance Current	$0 \leq A, B \leq V_{CC}$	-	-	± 1	μA
R_{ON}	Switch On-Resistance ⁽³⁾	$V_{CC} = \text{Min.}, V_{IN} = 0.0\text{V}$ $I_{ON} = -48\text{mA}$ or -64mA	-	4	6	Ω
		$V_{CC} = \text{Min.}, V_{IN} = 3.6\text{V}$ $I_{ON} = -15\text{mA}$	-	5	8	

Notes:

- For Max. or Min. conditions, use appropriate value specified under Electrical Characteristics for the applicable device type.
- Typical values are at $V_{CC} = 3.3\text{V}$, $T_A = 25^\circ\text{C}$ ambient and maximum loading.
- Measured by the voltage drop between A and B pin at indicated current through the switch. ON resistance is determined by the lower of the voltages on the two (Ax, Bx) pins.

2.5V supply (Over operating range, $T_A = -40 \sim +85^\circ\text{C}$, $V_{CC} = 2.5V \pm 10\%$, unless otherwise noted)

Symbol	Description	Test Conditions ⁽¹⁾	Min	Typ ⁽²⁾	Max	Unit
V_{IH}	Control Input HIGH Voltage	Guaranteed Logic HIGH Level	1.8	-	$V_{CC} + 0.3$	V
V_{IL}	Control Input LOW Voltage	Guaranteed Logic LOW Level	-0.3	-	0.8	V
V_{IK}	Clamp Diode Voltage	$V_{CC} = \text{Max.}, I_{IN} = -6\text{mA}$	-	-0.7	-1.8	V
I_{IH}	Input HIGH Current	$V_{CC} = \text{Max.}, V_{IN} = V_{CC}$	-	-	± 1	μA
I_{IL}	Input Low Current	$V_{CC} = \text{Max.}, V_{IN} = \text{GND}$	-	-	± 1	μA
I_{OZH}	High-Impedance Current	$0 \leq A, B \leq V_{CC}$	-	-	± 1	μA
R_{ON}	Switch On-Resistance ⁽³⁾	$V_{CC} = \text{Min.}, V_{IN} = 0.0\text{V}$ $I_{ON} = -48\text{mA}$	-	4	8	Ω
		$V_{CC} = \text{Min.}, V_{IN} = 2.25\text{V}$ $I_{ON} = -15\text{mA}$	-	7	14	

Notes:

- For Max. or Min. conditions, use appropriate value specified under Electrical Characteristics for the applicable device type.
- Typical values are at $V_{CC} = 2.5\text{V}$, $T_A = 25^\circ\text{C}$ ambient and maximum loading.
- Measured by the voltage drop between A and B pin at indicated current through the switch. ON resistance is determined by the lower of the voltages on the two (Ax, Bx) pins.

1.8V supply (Over operating range, $T_A = -40 \sim +85^\circ\text{C}$, $V_{CC} = 1.8\text{V} \pm 10\%$, unless otherwise noted)

Symbol	Description	Test Conditions ⁽¹⁾	Min	Typ ⁽²⁾	Max	Unit
V_{IH}	Control Input HIGH Voltage	Guaranteed Logic HIGH Level	1.2	-	$V_{CC} + 0.3$	V
V_{IL}	Control Input LOW Voltage	Guaranteed Logic LOW Level	-0.3	-	0.6	V
V_{IK}	Clamp Diode Voltage	$V_{CC} = \text{Min.}, I_{IN} = -18\text{mA}$	-	-0.7	-1.8	V
I_{IH}	Input HIGH Current	$V_{CC} = \text{Max.}, V_{IN} = V_{CC}$	-	-	± 1	μA
I_{IL}	Input LOW Current	$V_{CC} = \text{Max.}, V_{IN} = \text{GND}$	-	-	± 1	μA
I_{OZH}	High-Impedance Current	$0 \leq A, B \leq V_{CC}$	-	-	± 1	μA
R_{ON}	Switch On-Resistance ⁽³⁾	$V_{CC} = \text{Min.}, V_{IN} = 0.0\text{V}$ $I_{ON} = -48\text{mA}$	-	4	8	Ω
		$V_{CC} = \text{Min.}, V_{IN} = 1.6\text{V}$ $I_{ON} = -15\text{mA}$	-	10	25	

Notes:

- For Max. or Min. conditions, use appropriate value specified under Electrical Characteristics for the applicable device type.
- Typical values are at $V_{CC} = 1.8\text{V}$, $T_A = 25^\circ\text{C}$ ambient and maximum loading.
- Measured by the voltage drop between A and B pin at indicated current through the switch. ON resistance is determined by the lower of the voltages on the two (Ax, Bx) pins.

Capacitance ($T_A = 25^\circ\text{C}$, $f = 1\text{MHz}$)

Symbol ⁽¹⁾	Description	Test Conditions	Typ ⁽²⁾	Unit
C_{IN}	Input Capacitance	$V_{IN} = 0\text{V}$	2.0	μF
C_{OFF}	A/B Capacitance, Switch Off		3.5	
C_{ON}	A/B Capacitance, Switch On		7.0	

Note:

- These parameters are determined by device characterization but are not production tested

Power Supply Characteristics

Symbol	Description	Test Conditions ⁽¹⁾	Min	Typ ⁽²⁾	Max	Unit
I_{CC}	Quiescent Power Supply Current	$V_{CC} = 3.6\text{V}, V_{IN} = \text{GND or } V_{CC}$	-	0.2	0.5	mA

Note:

- For Max. or Min. conditions, use appropriate value specified under Electrical Characteristics for the applicable device.
- Typical values are at $+25^\circ\text{C}$ ambient.

Dynamic Electrical Characteristics

 (Over Operating Range, $T_A = -40 \sim +85^\circ\text{C}$, $V_{CC} = 3.3\text{V} \pm 10\%$)

Symbol	Description	Test Conditions	Min	Type	Max	Unit
X_{TALK}	Crosstalk	10MHz	-	-60	-	dB
O_{IRR}	Off-Isolation	10MHz	-	-60	-	
BW	-3dB Bandwidth	See test Diagram	-	500	-	MHz

Switch Characteristics

Over 3.3V Operating Range

Symbol	Description	Test Conditions ⁽¹⁾	Min	Typ	Max	Unit
t_{PLH}, t_{PHL}	Propagation Delay ^(2, 3) Ax to Bx, Bx to Ax	See test Diagram	-	-	0.3	ns
t_{PZH}, t_{PZL}	Enable Time \overline{EN} , EN to Ax or Bx	See test Diagram	1.5	-	9.0	
t_{PHZ}, t_{PLZ}	Disable Time \overline{EN} , EN to Ax or Bx	See test Diagram	1.5	-	9.0	

Note:

1. See test circuit and waveforms.
2. This parameter is guaranteed but not tested on Propagation Delays.
3. The switch contributes no propagation delay other than the RC delay of the On-Resistance of the switch and the load capacitance. The time constant for the switch alone is of the order of 0.30ns for 10pF load. Since this time constant is much smaller than the rise/fall times of typical driving signals, it adds very little propagation delay to the system. Propagation delay of the switch when used in a system is determined by the driving circuit on the driving side of the switch and its interaction with the load on the driven side.

Over 2.5V Operating Range

Symbol	Description	Test Conditions ⁽¹⁾	Min	Typ	Max	Unit
t_{PLH}, t_{PHL}	Propagation Delay ^(2, 3) Ax to Bx, Bx to Ax	See test Diagram	-	-	0.3	ns
t_{PZH}, t_{PZL}	Enable Time \overline{EN} , EN to Ax or Bx	See test Diagram	1.5	-	15.0	
t_{PHZ}, t_{PLZ}	Disable Time \overline{EN} , EN to Ax or Bx	See test Diagram	1.5	-	12.0	

Note:

1. See test circuit and waveforms.
2. This parameter is guaranteed but not tested on Propagation Delays.
3. The switch contributes no propagation delay other than the RC delay of the On-Resistance of the switch and the load capacitance. The time constant for the switch alone is of the order of 0.30ns for 10pF load. Since this time constant is much smaller than the rise/fall times of typical driving signals, it adds very little propagation delay to the system. Propagation delay of the switch when used in a system is determined by the driving circuit on the driving side of the switch and its interaction with the load on the driven side.

Over 1.8V Operating Range

Symbol	Description	Test Conditions ⁽¹⁾	Min	Typ	Max	Unit
t_{PLH}, t_{PHL}	Propagation Delay ^(2, 3) Ax to Bx, Bx to Ax	See test Diagram	-	-	0.3	ns
t_{PZH}, t_{PZL}	Enable Time \overline{EN} , EN to Ax or Bx	See test Diagram	1.5	-	25.0	
t_{PHZ}, t_{PLZ}	Disable Time \overline{EN} , EN to Ax or Bx	See test Diagram	1.5	-	12.0	

Note:

1. See test circuit and waveforms.
2. This parameter is guaranteed but not tested on Propagation Delays.
3. The switch contributes no propagation delay other than the RC delay of the On-Resistance of the switch and the load capacitance. The time constant for the switch alone is of the order of 0.30ns for 10pF load. Since this time constant is much smaller than the rise/fall times of typical driving signals, it adds very little propagation delay to the system. Propagation delay of the switch when used in a system is determined by the driving circuit on the driving side of the switch and its interaction with the load on the driven side.

Test Circuit for Electrical Characteristics

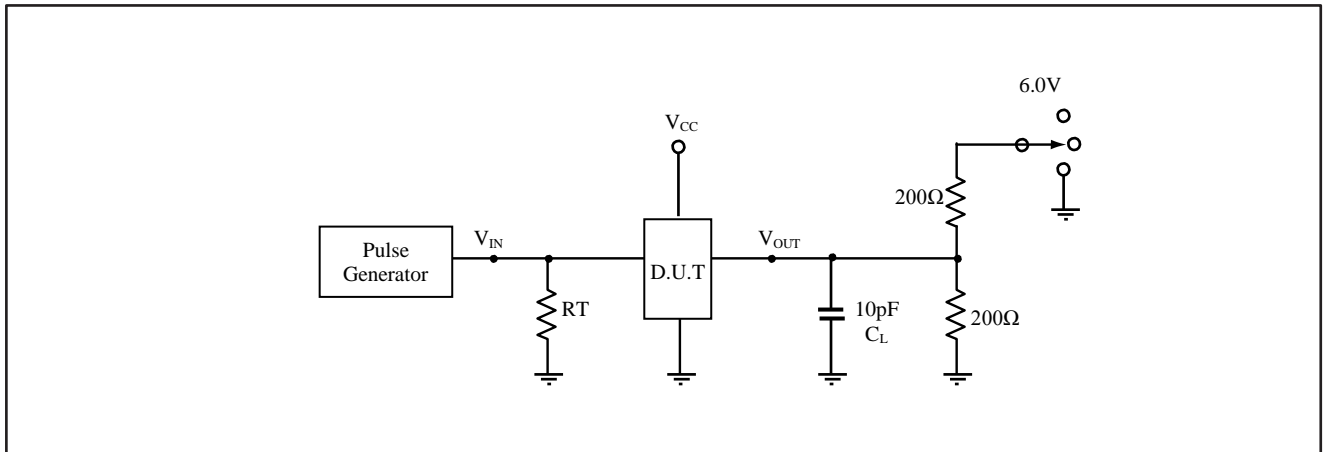

Notes:

1. C_L = Load capacitance: includes jig and probe capacitance.
2. R_T = Termination resistance: should be equal to Z_{OUT} of the Pulse Generator
3. All input impulses are supplied by generators having the following characteristics: $PRR \leq 10$ MHz, $Z_O = 50$ -ohm, $t_R \leq 2.5$ ns, $t_F \leq 2.5$ ns.
4. The outputs are measured one at a time with one transition per measurement.

Switch Positions

Test	Switch
t_{PLZ} , t_{PZL}	6.0V
t_{PHZ} , t_{PZH}	GND
Prop Delay	Open

Test Circuit for Dynamic Electrical Characteristics

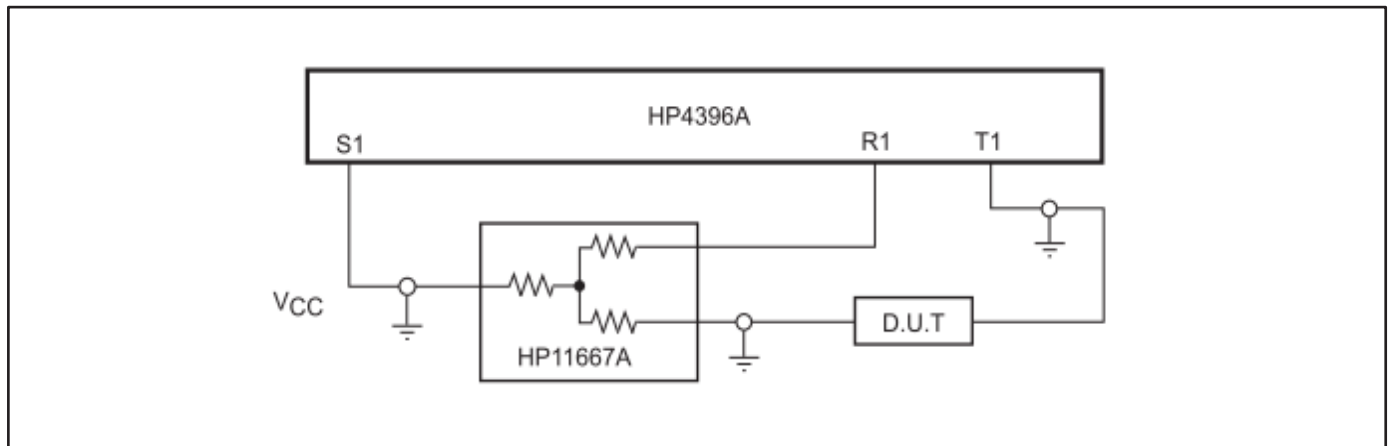

Switching Waveform

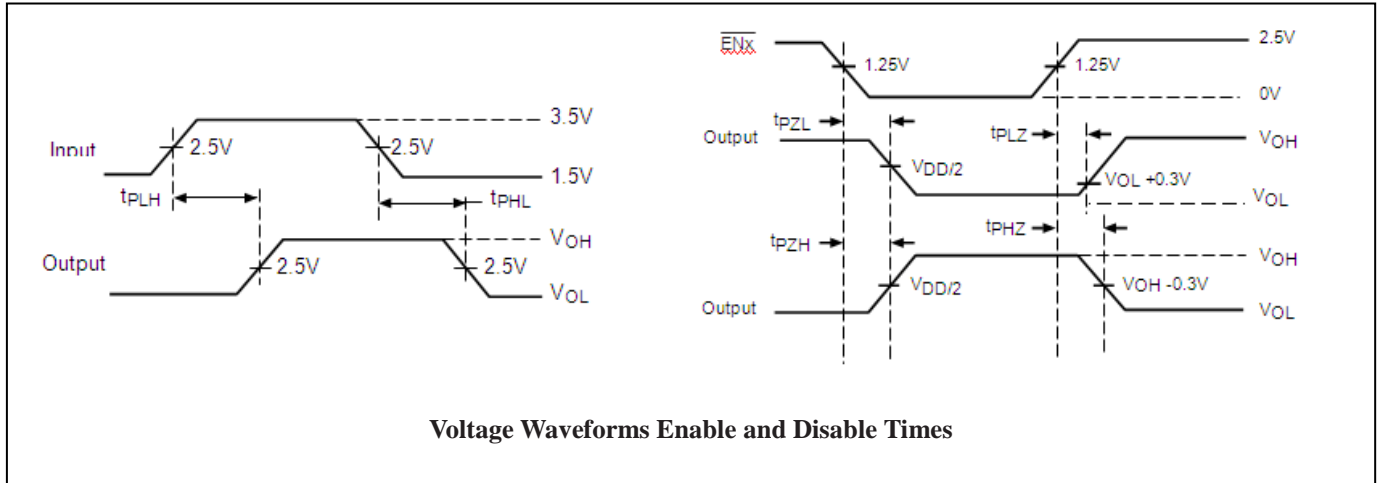

Applications Information

Logic Inputs

The logic control inputs can be driven up to 3.6V regardless of the supply voltage. For example, given a +3.3V supply, \overline{EN} may be driven LOW to 0V and HIGH to 3.6V. Driving \overline{EN} Rail-to-Rail minimizes power consumption.

Hot Insertion

For Datacom and Telecom applications that have ten or more volts passing through the backplane, a high voltage from the power supply may be seen at the device input pins during hot insertion. The PI3CH1012 devices have maximum limits of 6V and 120mA for 20ns. If the power is higher or applied for a longer time or repeatedly reaches the maximum limits, the devices can be damaged.

Rail-to-Rail is a registered trademark of Nippon Motorola, Ltd.

Part Marking

Q Package



Z: Fixed Code
YY: Year
WW: Workweek
1st G: Assembly Code
2nd G: Fab Code

Packaging Mechanical

24- QSOP (Q)

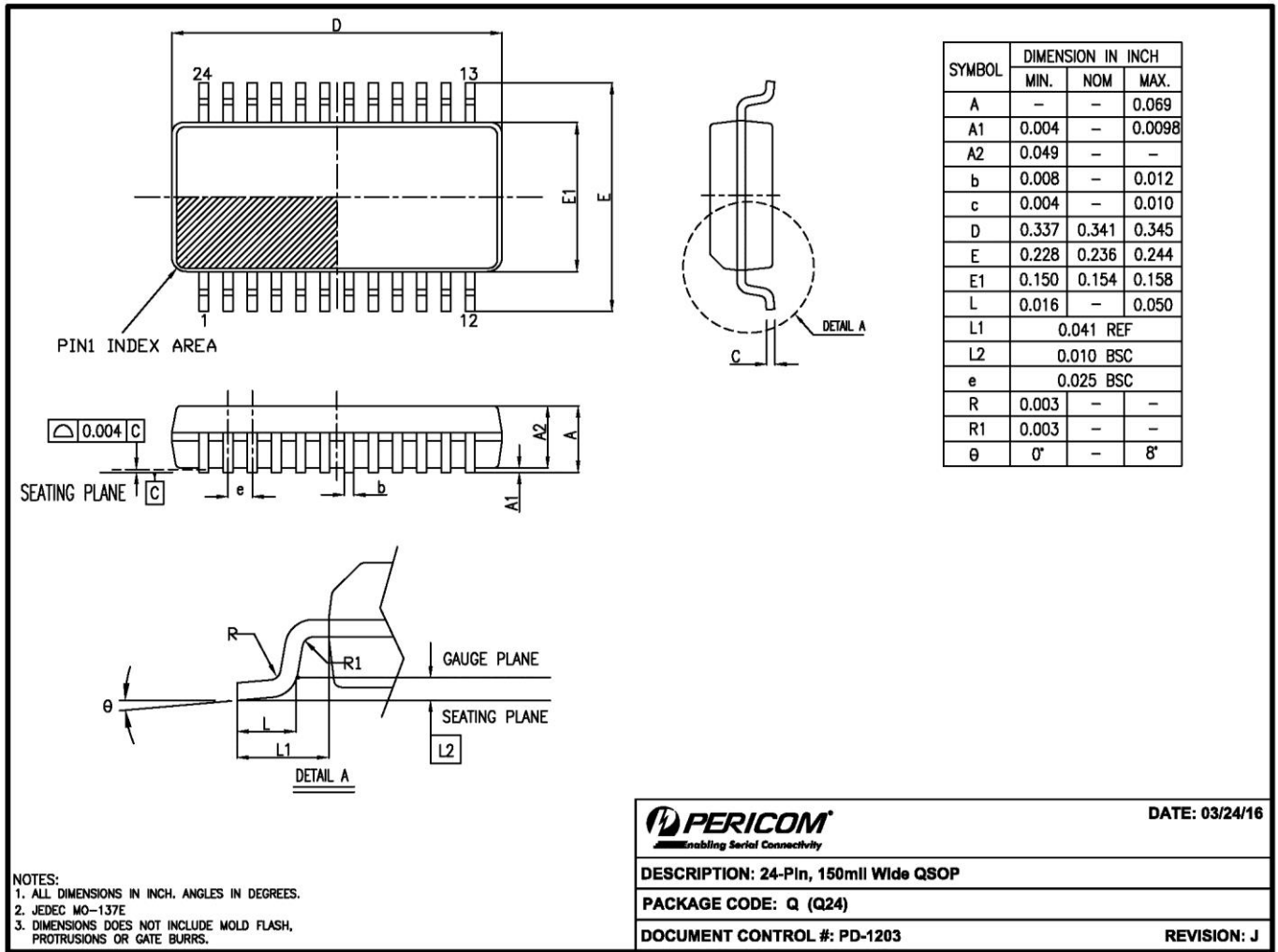

For latest package info.

please check: <http://www.diodes.com/design/support/packaging/pericom-packaging/packaging-mechanicals-and-thermal-characteristics/>

Ordering Information

Part No.	Package Cede	Package
PI3CH1012QEX	Q	24-Pin, 150-mil Wide (QSOP)

- Notes:
- EU Directive 2002/95/EC (RoHS), 2011/65/EU (RoHS 2) & 2015/863/EU (RoHS 3) compliant. All applicable RoHS exemptions applied.
 - See <http://www.diodes.com/quality/lead-free/> for more information about Diodes Incorporated’s definitions of Halogen- and Antimony-free, “Green” and Lead-free.
 - Thermal characteristics can be found on the company web site at www.diodes.com/design/support/packaging/
 - E = Pb-free and Green
 - X suffix = Tape/Reel

IMPORTANT NOTICE

DIODES INCORPORATED MAKES NO WARRANTY OF ANY KIND, EXPRESS OR IMPLIED, WITH REGARDS TO THIS DOCUMENT, INCLUDING, BUT NOT LIMITED TO, THE IMPLIED WARRANTIES OF MERCHANTABILITY AND FITNESS FOR A PARTICULAR PURPOSE (AND THEIR EQUIVALENTS UNDER THE LAWS OF ANY JURISDICTION).

Diodes Incorporated and its subsidiaries reserve the right to make modifications, enhancements, improvements, corrections or other changes without further notice to this document and any product described herein. Diodes Incorporated does not assume any liability arising out of the application or use of this document or any product described herein; neither does Diodes Incorporated convey any license under its patent or trademark rights, nor the rights of others. Any Customer or user of this document or products described herein in such applications shall assume all risks of such use and will agree to hold Diodes Incorporated and all the companies whose products are represented on Diodes Incorporated website, harmless against all damages.

Diodes Incorporated does not warrant or accept any liability whatsoever in respect of any products purchased through unauthorized sales channel.

Should Customers purchase or use Diodes Incorporated products for any unintended or unauthorized application, Customers shall indemnify and hold Diodes Incorporated and its representatives harmless against all claims, damages, expenses, and attorney fees arising out of, directly or indirectly, any claim of personal injury or death associated with such unintended or unauthorized application.

Products described herein may be covered by one or more United States, international or foreign patents pending. Product names and markings noted herein may also be covered by one or more United States, international or foreign trademarks.

This document is written in English but may be translated into multiple languages for reference. Only the English version of this document is the final and determinative format released by Diodes Incorporated.

LIFE SUPPORT

Diodes Incorporated products are specifically not authorized for use as critical components in life support devices or systems without the express written approval of the Chief Executive Officer of Diodes Incorporated. As used herein:

A. Life support devices or systems are devices or systems which:

1. are intended to implant into the body, or
2. support or sustain life and whose failure to perform when properly used in accordance with instructions for use provided in the labeling can be reasonably expected to result in significant injury to the user.



B. A critical component is any component in a life support device or system whose failure to perform can be reasonably expected to cause the failure of the life support device or to affect its safety or effectiveness.

Customers represent that they have all necessary expertise in the safety and regulatory ramifications of their life support devices or systems, and acknowledge and agree that they are solely responsible for all legal, regulatory and safety-related requirements concerning their products and any use of Diodes Incorporated products in such safety-critical, life support devices or systems, notwithstanding any devices- or systems-related information or support that may be provided by Diodes Incorporated. Further, Customers must fully indemnify Diodes Incorporated and its representatives against any damages arising out of the use of Diodes Incorporated products in such safety-critical, life support devices or systems.



Copyright © 2016, Diodes Incorporated
www.diodes.com

Looking for pricing, stock, or lifecycle information?

Click below to explore more details on WIN SOURCE:

-  [View PI3CH1012QE on WIN SOURCE](#)
-  [Diodes Incorporated](#) Information

Optimize Your Supply Chain with WIN SOURCE Solutions

-  Global Sourcing Solution
-  Obsolete Management
-  Cost Control Management
-  Shortage Management
-  Alternative Solution
-  Excess Inventory Management