

8-Channel, High-Bandwidth, Analog Front-End

Check for Samples: [PGA5807](#)

FEATURES

- **8-Channel Complete AFE:**
 - LNA, PGA, and LPF
 - Full-Channel Gain: 12 dB to 30 dB
 - Input-Referred Noise: $2.1 \text{ nV}/\sqrt{\text{Hz}}$
- **LNA:**
 - Gain: 12 dB
 - Fully Differential
 - Wide Input Common-Mode Support: $2.1 \pm 200 \text{ mV}$
 - Maximum Linear Input Range: $500 \text{ mV}_{\text{PP}}$
- **PGA: Gain 0 dB to 18 dB**
 - With 3-dB Gain Steps
 - Programmable via Either Serial Interface or External Pins
- **Maximum Total Channel Gain: 30 dB**
- **Programmable LPF:**
 - Corner Frequency: 75 MHz, 60 MHz
- **Power (Full-Chain):**
 - 60 mW per Channel
- **Fast and Consistent Overload Recovery**
- **Small Package: 9-mm x 9-mm QFN-64**

APPLICATIONS

- **Data Acquisition Front Ends**
- **Ultrasound Imaging**

DESCRIPTION

The PGA5807 is an 8-channel, high-bandwidth, analog front-end (AFE). The device functions on a single 3.3-V analog supply. The device supports high-bandwidth input frequencies with a total power of 60 mW per channel. The PGA5807 consists of a low-noise amplifier (LNA), a programmable gain amplifier (PGA), and a programmable low-pass filter (LPF). The LNA has a fixed 12-dB gain (the differential amplifier supports both direct and capacitive input coupling) and supports a maximum linear input range of $500 \text{ mV}_{\text{PP}}$.

The device provides gain options from 0 dB to 18 dB, in 3-dB gain steps. This 18-dB PGA gain can be programmed using either the serial interface or external pins. The PGA5807 integrates an antialiasing filter in the form of an LPF to reduce noise. The device is available in a very small, 9-mm x 9-mm QFN-64 package and is specified for operation over the -40°C to $+85^{\circ}\text{C}$ temperature range.



Please be aware that an important notice concerning availability, standard warranty, and use in critical applications of Texas Instruments semiconductor products and disclaimers thereto appears at the end of this data sheet.

All trademarks are the property of their respective owners.



This integrated circuit can be damaged by ESD. Texas Instruments recommends that all integrated circuits be handled with appropriate precautions. Failure to observe proper handling and installation procedures can cause damage.

ESD damage can range from subtle performance degradation to complete device failure. Precision integrated circuits may be more susceptible to damage because very small parametric changes could cause the device not to meet its published specifications.

ORDERING INFORMATION⁽¹⁾

PRODUCT	PACKAGE-LEAD	PACKAGE DESIGNATOR
PGA5807	QFN-64	RGC

(1) For the most current package and ordering information, see the Package Option Addendum at the end of this document, or visit the device product folder at www.ti.com.

ABSOLUTE MAXIMUM RATINGS

Over operating free-air temperature range, unless otherwise noted.⁽¹⁾

		VALUE	UNIT
Supply voltage range	AVDD	–0.3 to 3.9	V
Voltage at analog input and digital input		–0.3 to minimum (3.6, AVDD + 0.3)	V
Temperature range	Operating, T _A	–40 to +85	°C
	Storage, T _{stg}	–55 to +150	°C
Electrostatic discharge (ESD) ratings	Human body model (HBM)	1	kV

(1) Stresses beyond those listed under *Absolute Maximum Ratings* may cause permanent damage to the device. These are stress ratings only, and do not imply functional operation of the device at these or any other conditions beyond those indicated under *Recommended Operating Conditions*. Exposure to absolute-maximum-rated conditions for extended periods may affect device reliability.

RECOMMENDED OPERATING CONDITIONS

		MIN	NOM	MAX	UNIT
AVDD	Analog voltage supply	3.15		3.6	V
T _A	Operating temperature	–40		+85	°C
	Input common-mode voltage range	1.9		2.3	V

THERMAL INFORMATION

THERMAL METRIC ⁽¹⁾		PGA5807	UNITS
		RGC (QFN)	
		64 PINS	
θ _{JA}	Junction-to-ambient thermal resistance	22.8	°C/W
θ _{JCtop}	Junction-to-case (top) thermal resistance	6.9	
θ _{JB}	Junction-to-board thermal resistance	2.4	
ψ _{JT}	Junction-to-top characterization parameter	0.1	
ψ _{JB}	Junction-to-board characterization parameter	2.4	
θ _{JCbot}	Junction-to-case (bottom) thermal resistance	0.2	

(1) For more information about traditional and new thermal metrics, see the *IC Package Thermal Metrics* application report, [SPRA953](http://www.ti.com).

ELECTRICAL CHARACTERISTICS

Typical values are at $T_A = +25^\circ\text{C}$, $AVDD = 3.3\text{ V}$, input dc-coupled with a 2.1-V common-mode voltage, LNA gain = 12 dB, PGA gain = 18 dB, total channel gain = 30 dB, bandwidth = high, and $V_{OUT} = -1\text{ dBFS}$, unless otherwise specified. Minimum and maximum values are specified across the full temperature range of $T_{MIN} = -40^\circ\text{C}$ to $T_{MAX} = +85^\circ\text{C}$ with $AVDD = 3.3\text{ V}$.

PARAMETER		TEST CONDITIONS	MIN	TYP	MAX	UNIT	
Input-referred noise		$f = 25\text{ MHz}$, total channel gain = 30 dB		2.1		$\text{nV}/\sqrt{\text{Hz}}$	
Noise figure		$R_S = 100\ \Omega$, differential		6.4		dB	
Maximum linear input voltage		Total channel gain = 12 dB, differential		500		mV_{PP}	
Maximum linear output swing				2		V_{PP}	
G_{LNA}	LNA gain			12		dB	
Maximum channel gain			29	30	31	dB	
PGA gain range			0		18	dB	
Gain step				3		dB	
Total output-referred noise		Total channel gain = 30 dB		450		μV	
Input resistance				5		$\text{k}\Omega$	
C_i	Input capacitance			3		pF	
LPF -3-dB cutoff frequency				75		MHz	
Gain matching		Across devices, $T_A = +25^\circ\text{C}$	-1		1	dB	
		Across channels in the same device		± 0.25		dB	
V_{ICR}	Input common-mode voltage range		1.9		2.3	V	
Output offset			-50		50	mV	
V_{OCR}	Output common-mode voltage			950		mV	
HD2	Harmonic distortion	Second	$f = 25\text{ MHz}$, $V_{OUT} = -1\text{ dBFS}$			-55	dBc
HD3		Third	$f = 25\text{ MHz}$, $V_{OUT} = -1\text{ dBFS}$			-50	dBc
THD		Total	$f = 25\text{ MHz}$, $V_{OUT} = -1\text{ dBFS}$			-48	dBc
IMD3	Intermodulation distortion	$f_1 = 25\text{ MHz}$ at -7 dBFS , $f_2 = 25\text{ MHz}$, 1 MHz at -7 dBFS , for all PGA gains				-45	dBc
Fundamental crosstalk		$f = 25\text{ MHz}$, $V_{OUT} = -1\text{ dBFS}$				-50	dBc
P_D	Power dissipation	Total, per channel		60	69	mW/ch	
		Power-down mode	Partial power-down		4.2	mW/ch	
			Complete power-down			2.5	mW/ch
AVDD current (3.3 V)				145		mA	
Settling time for overload recovery		For 12-dB higher signal than linear input				-30	ns
Power-up response time		Partial power-down				1	μs
		Full power-down				1	ms
PSRR	Power-supply rejection ratio	$f = 10\text{ kHz}$, gain = 30 dB				-40	dBc
		$f = 10\text{ kHz}$, gain = 12 dB				-38	dBc

DIGITAL CHARACTERISTICS

Typical values are at $T_A = +25^{\circ}\text{C}$ and $AVDD = 3.3\text{ V}$, unless otherwise specified. Minimum and maximum values are specified across the full temperature range of $T_{\text{MIN}} = -40^{\circ}\text{C}$ to $T_{\text{MAX}} = +85^{\circ}\text{C}$.

PARAMETER		TEST CONDITIONS	MIN	TYP	MAX	UNIT
DIGITAL INPUTS/OUTPUTS						
V_{IH}	Logic high input voltage		2			V
V_{IL}	Logic low input voltage		0			V
I_{IH}	Logic high input current			200		μA
I_{IL}	Logic low input current			200		μA
C_i	Input capacitance			5		pF
V_{OH}	Logic high output voltage	SDOUT pin		AVDD		V
V_{OL}	Logic low output voltage	SDOUT pin		0		V

PIN CONFIGURATION

**RGC PACKAGE
QFN-64
(TOP VIEW)**

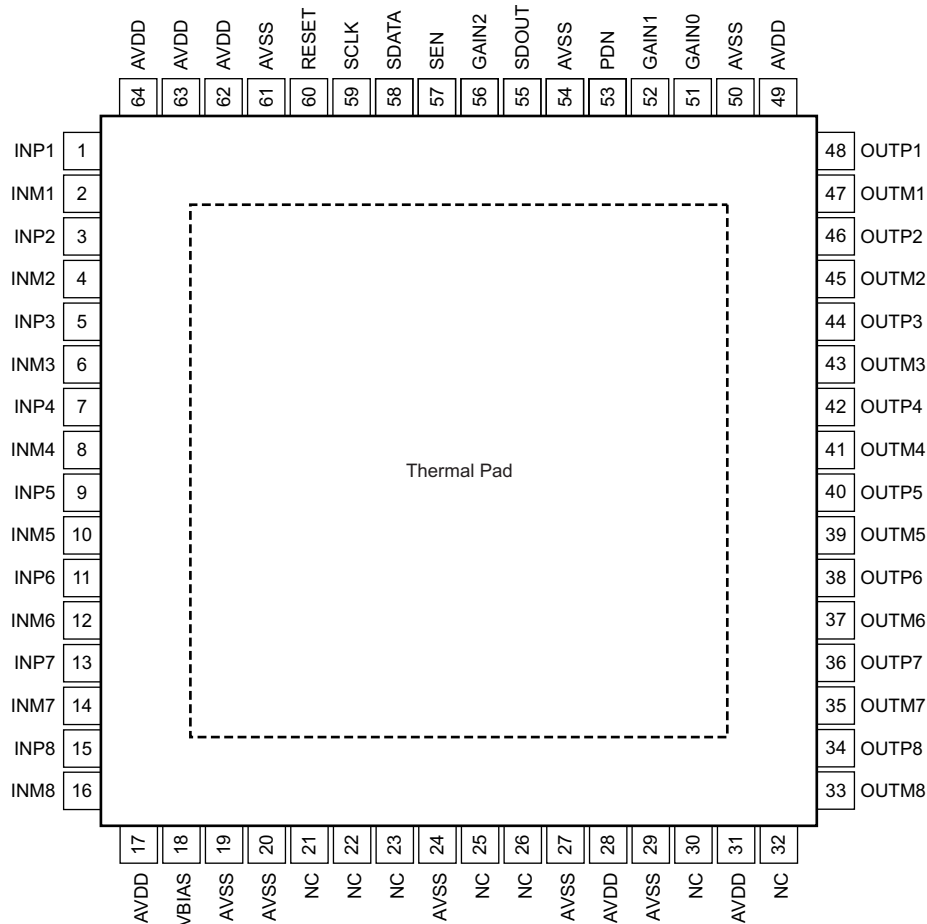

Table 1. PIN FUNCTIONS

NAME	NO.	FUNCTION	DESCRIPTION
AVDD	17, 28, 31, 49, 62-64	Supply	Analog supply pin, 3.3 V
AVSS	19, 20, 24, 27, 29, 50, 54, 61	Ground	Analog ground
GAIN0	51	Digital input	When RESET is high, this pin is used to program the PGA gain. Refer to Table 2 for more details. Note: Use 3.3-V logic.
GAIN1	52	Digital input	When RESET is high, this pin is used to program the PGA gain. Refer to Table 2 for more details. Note: Use 3.3-V logic.
GAIN2	56	Digital input	When RESET is high, this pin is used to program the PGA gain. Refer to Table 2 for more details. Note: Use 3.3-V logic.
INM1 to INM8	2, 4, 6, 8, 10, 12, 14, 16	Input	Complimentary analog inputs for channels 1 to 8. The dc input common-mode can be 2.1 V \pm 200 mV.
INP1 to INP8	1, 3, 5, 7, 9, 11, 13, 15	Input	Analog inputs for channels 1 to 8. The dc input common-mode can be 2.1 V \pm 200 mV.
NC	21-23, 25, 26, 30, 32	—	Unused pins; do not connect
OUTM1 to OUTM8	33, 35, 37, 39, 41, 43, 45, 47	Output	Complimentary output pins with a 0.95-V common-mode voltage
OUTP1 to OUTP8	34, 36, 38, 40, 42, 44, 46, 48	Output	Output pins with a 0.95-V common-mode voltage
PDN	53	Digital input	Partial power-down control pin for the entire device with an internal 20-k Ω pull-down resistor; active high. Note: Use 3.3-V logic.
RESET	60	Digital input	Logic hardware reset pin. Note: Use 3.3-V logic.
SCLK	59	Digital input	Serial interface clock pin with an internal 20-k Ω pull-down resistor. Note: Use 3.3-V logic.
SDATA	58	Digital input	Serial interface data input with an internal 20-k Ω pull-down resistor. When RESET is high, the corner frequency for the antialias filter can be programmed to a lower frequency (60 MHz) by setting this pin high. Note: Use 3.3-V logic.
SDOUT	55	Digital output	Serial interface readout pin
SEN	57	Digital input	Serial interface enabled for channels 1 to 8 with an internal 20-k Ω pull-up resistor; active low. Note: Use 3.3-V logic.
VBIAS	18	Decap	Bias voltage; bypass to ground with a 1- μ F capacitor or greater

Table 2. PGA Gain Control

GAIN[2:0]	PGA_GAIN (dB)
000	18
001	15
010	12
011	9
100	6
101	3
110	0

FUNCTIONAL BLOCK DIAGRAM

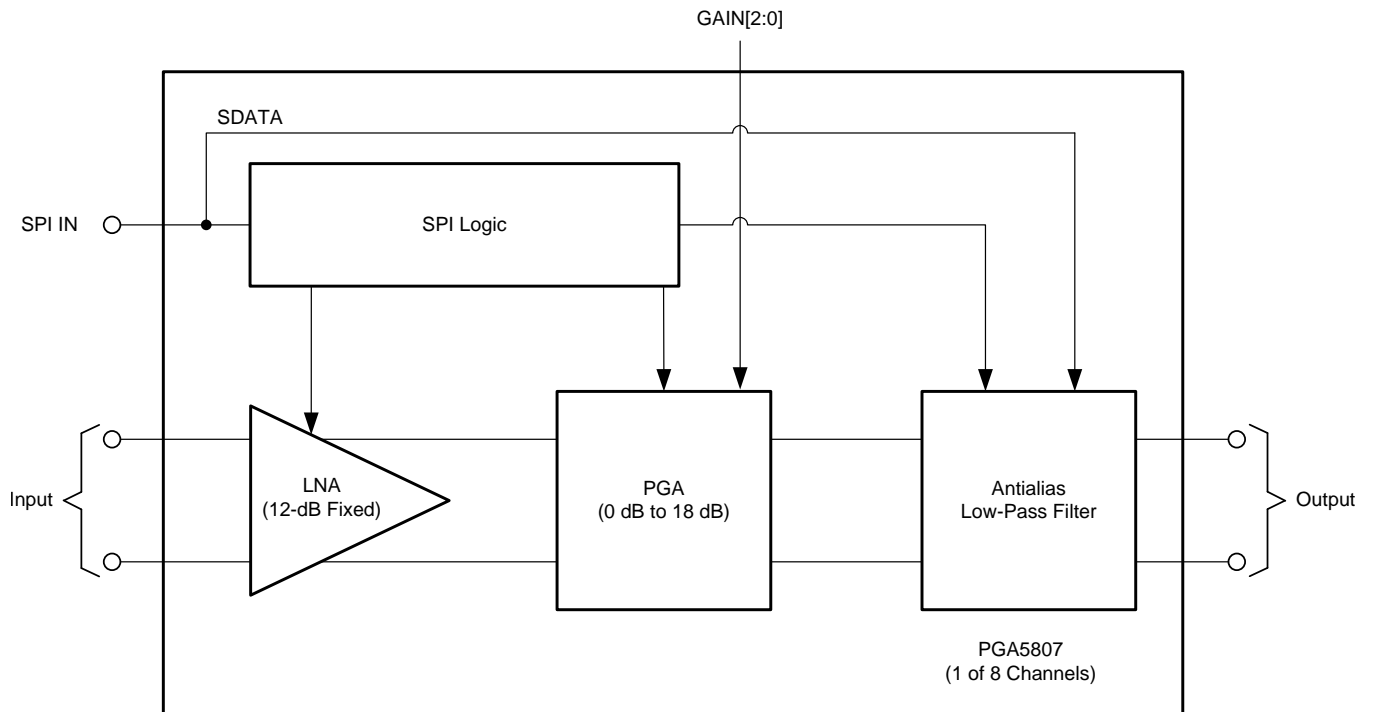

TYPICAL CHARACTERISTICS

At $T_A = +25^\circ\text{C}$, $AV_{DD} = 3.3\text{ V}$, input dc-coupled with 2.1-V input common-mode, LNA gain = 12 dB, PGA gain = 18 dB, total channel gain = 30 dB, $\text{GAIN}[2:0] = 000$, $f_{IN} = 5\text{ MHz}$, default LPF filter corner, and $V_{OUT} = -1\text{ dBFS}$, unless otherwise noted.

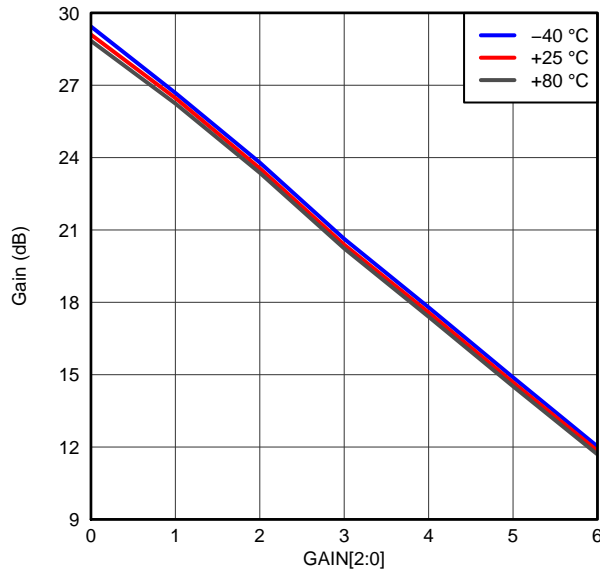

Figure 1. GAIN vs GAIN[2:0] ACROSS TEMPERATURE

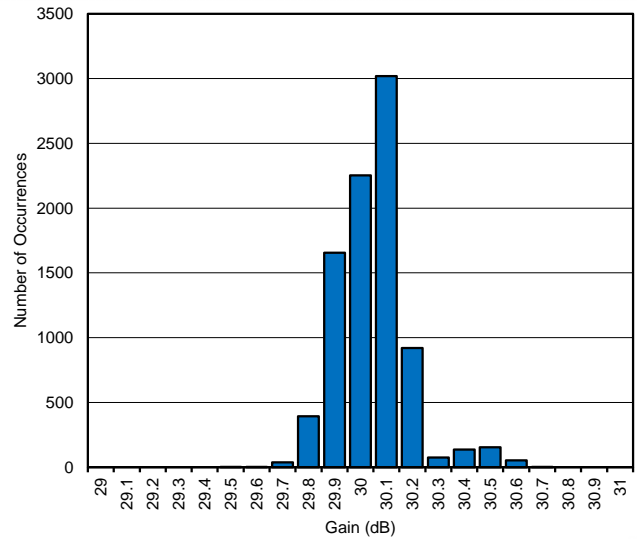

Figure 2. GAIN-MATCHING HISTOGRAM (Gain = 30 dB)

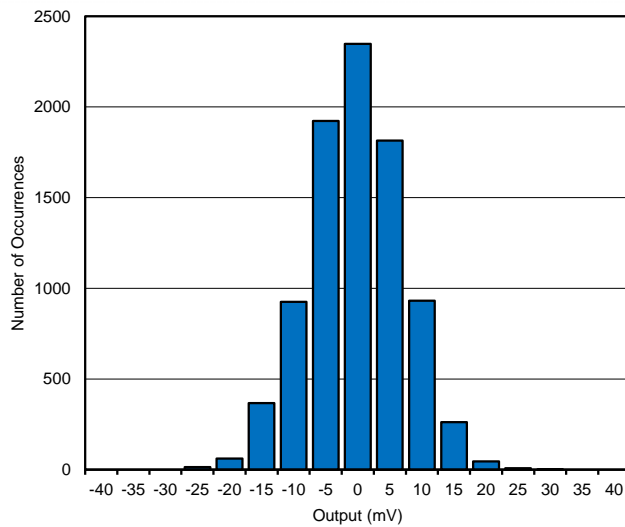

Figure 3. OUTPUT OFFSET HISTOGRAM (Gain = 30 dB)

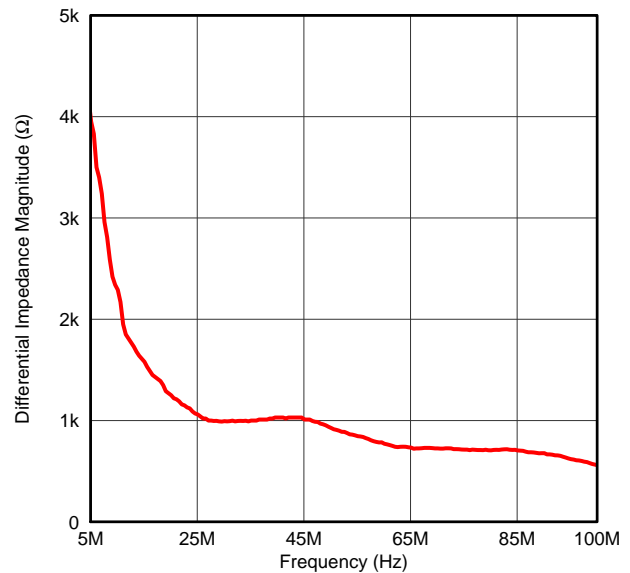

Figure 4. INPUT IMPEDANCE MAGNITUDE

TYPICAL CHARACTERISTICS (continued)

At $T_A = +25^\circ\text{C}$, $AV_{DD} = 3.3\text{ V}$, input dc-coupled with 2.1-V input common-mode, LNA gain = 12 dB, PGA gain = 18 dB, total channel gain = 30 dB, $GAIN[2:0] = 000$, $f_{IN} = 5\text{ MHz}$, default LPF filter corner, and $V_{OUT} = -1\text{ dBFS}$, unless otherwise noted.

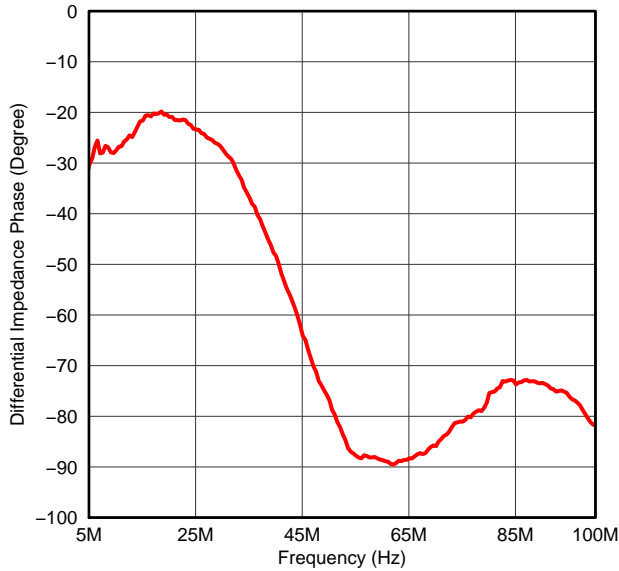

Figure 5. INPUT IMPEDANCE PHASE

G006

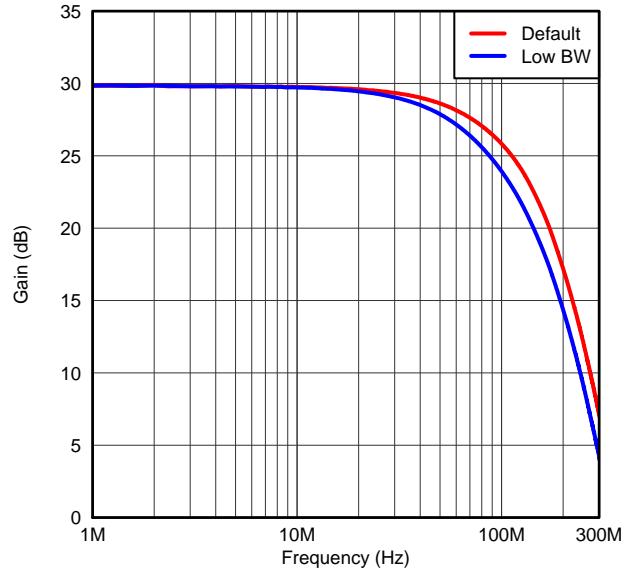

Figure 6. LOW-PASS FILTER RESPONSE

G007

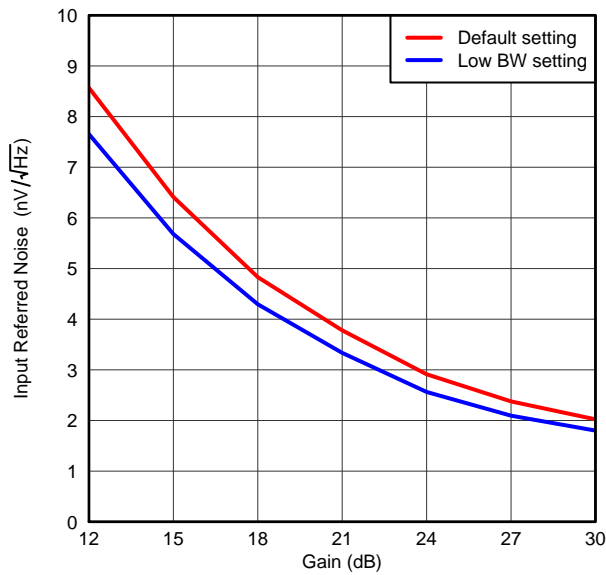

Figure 7. INPUT-REFERRED NOISE vs GAIN

G008

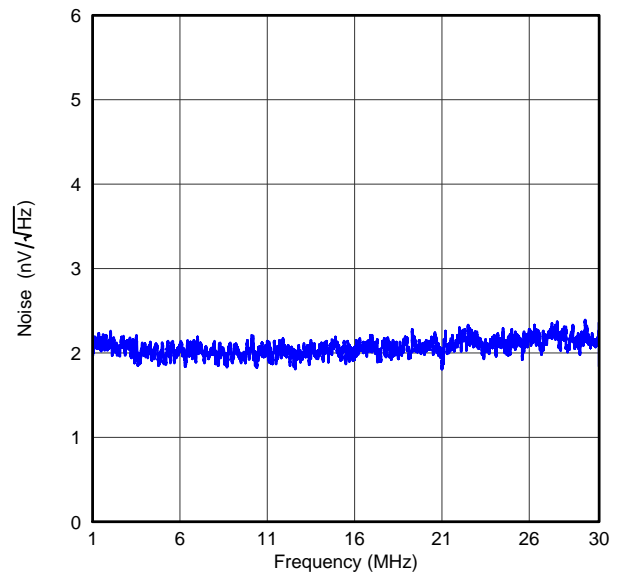

Figure 8. INPUT-REFERRED NOISE vs FREQUENCY (Gain = 30 dB)

G009

TYPICAL CHARACTERISTICS (continued)

At $T_A = +25^\circ\text{C}$, $AVDD = 3.3\text{ V}$, input dc-coupled with 2.1-V input common-mode, LNA gain = 12 dB, PGA gain = 18 dB, total channel gain = 30 dB, $\text{GAIN}[2:0] = 000$, $f_{IN} = 5\text{ MHz}$, default LPF filter corner, and $V_{OUT} = -1\text{ dBFS}$, unless otherwise noted.

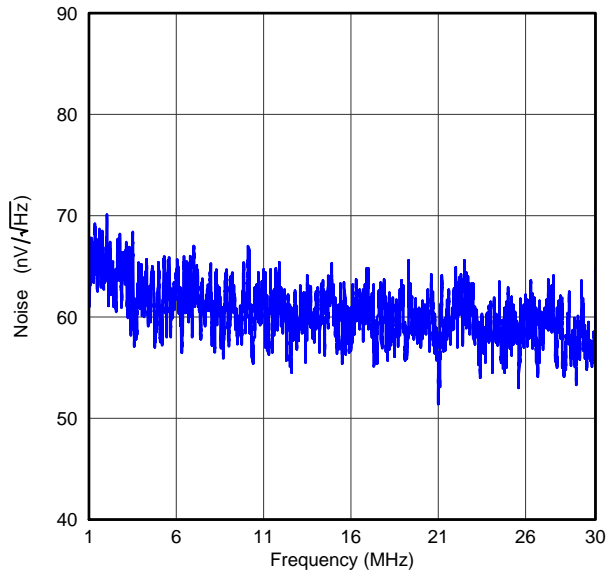

Figure 9. OUTPUT-REFERRED NOISE vs FREQUENCY (Gain = 30 dB) G010

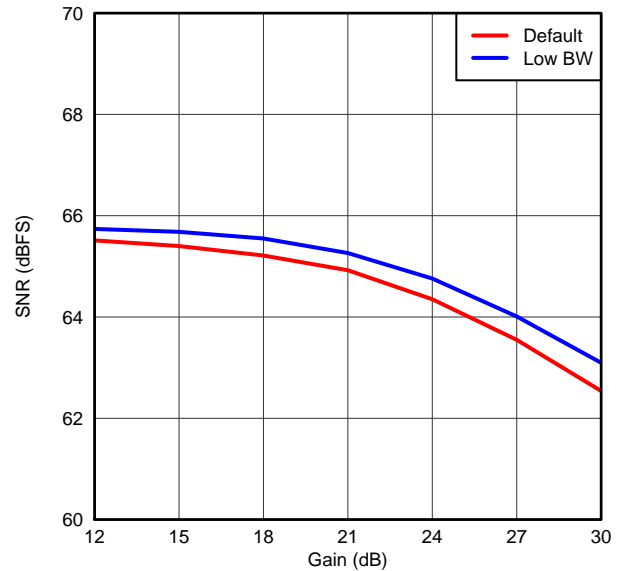

Figure 10. SIGNAL-TO-NOISE RATIO vs GAIN ACROSS BANDWIDTH MODE G011

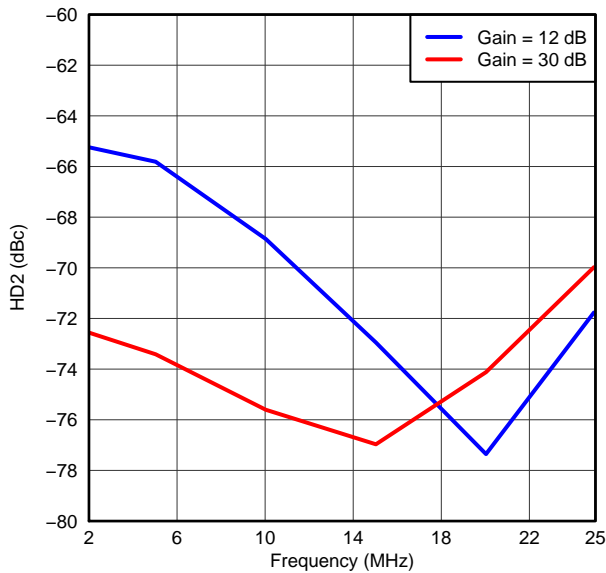

Figure 11. SECOND-HARMONIC DISTORTION vs FREQUENCY G012

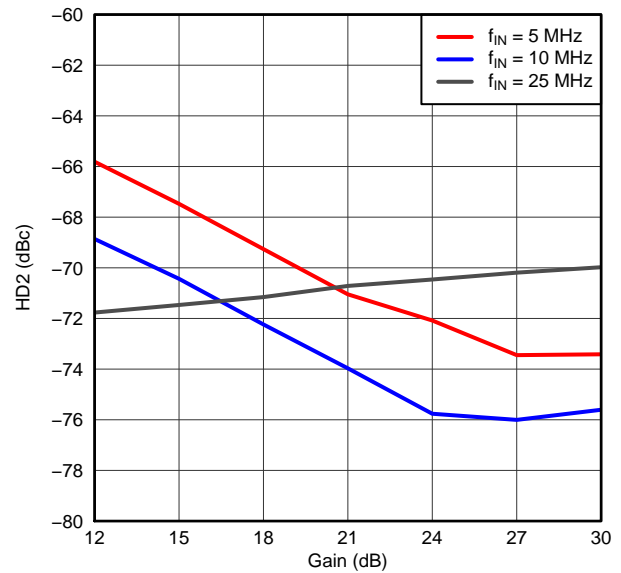

Figure 12. SECOND-HARMONIC DISTORTION vs GAIN G013

TYPICAL CHARACTERISTICS (continued)

At $T_A = +25^\circ\text{C}$, $AV_{DD} = 3.3\text{ V}$, input dc-coupled with 2.1-V input common-mode, LNA gain = 12 dB, PGA gain = 18 dB, total channel gain = 30 dB, $GAIN[2:0] = 000$, $f_{IN} = 5\text{ MHz}$, default LPF filter corner, and $V_{OUT} = -1\text{ dBFS}$, unless otherwise noted.

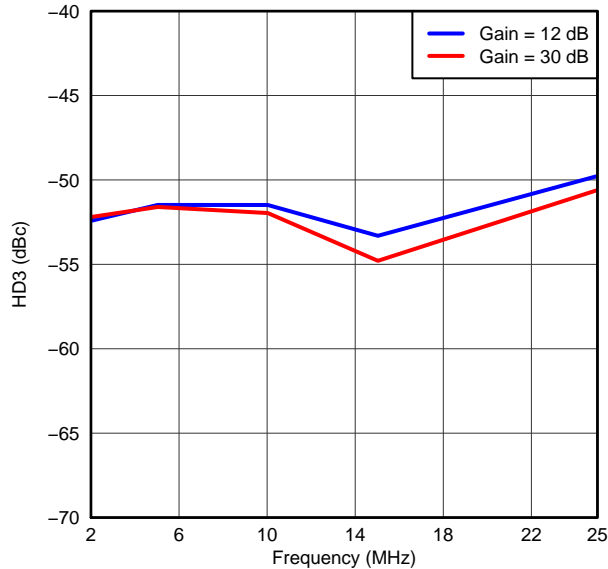

Figure 13. THIRD-HARMONIC DISTORTION vs FREQUENCY G014

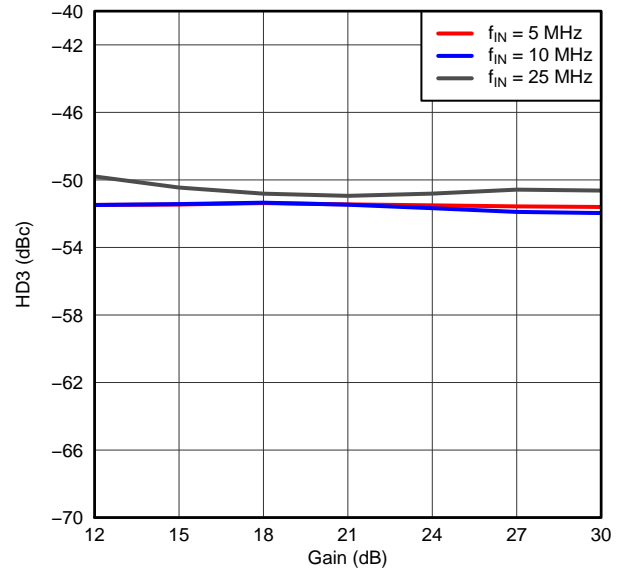

Figure 14. THIRD-HARMONIC DISTORTION vs GAIN G015

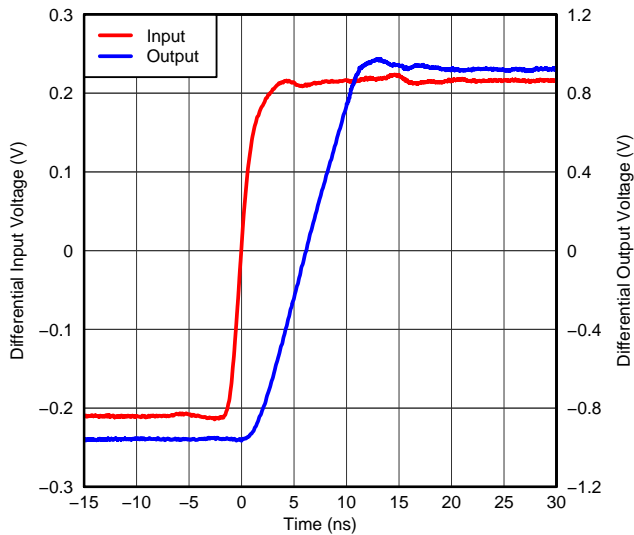

Figure 15. DIFFERENTIAL OUTPUT RESPONSE FOR AN INPUT STEP (12-dB Total Channel Gain) G016

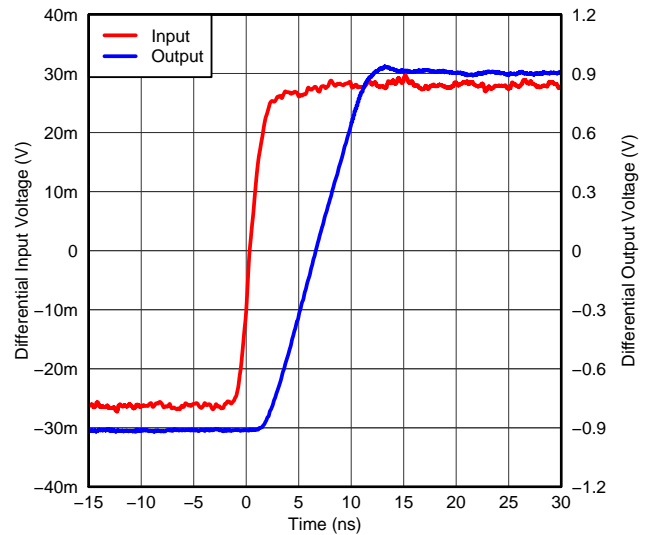

Figure 16. DIFFERENTIAL OUTPUT RESPONSE FOR AN INPUT STEP (30-dB Total Channel Gain) G017

TYPICAL CHARACTERISTICS (continued)

At $T_A = +25^\circ\text{C}$, $AV_{DD} = 3.3\text{ V}$, input dc-coupled with 2.1-V input common-mode, LNA gain = 12 dB, PGA gain = 18 dB, total channel gain = 30 dB, $GAIN[2:0] = 000$, $f_{IN} = 5\text{ MHz}$, default LPF filter corner, and $V_{OUT} = -1\text{ dBFS}$, unless otherwise noted.

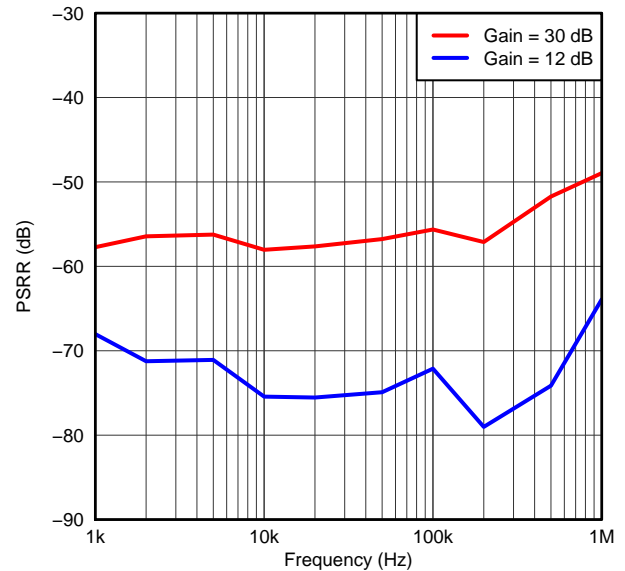

Figure 17. POWER-SUPPLY REJECTION RATIO (100-mV_{PP} Supply Noise with Different Frequencies)

SERIAL REGISTER TIMING

SERIAL REGISTER WRITE DESCRIPTION

Programming different modes can be accomplished through the serial interface formed by the SEN (serial interface enable), SCLK (serial interface clock), SDATA (serial interface data), and RESET pins. Each of these pins has a 20-k Ω pull-down resistor to GND. Serially shifting bits into the device is enabled when SEN is low. SDATA serial data are latched at every SCLK rising edge when SEN is active (low). Serial data are loaded into the register at every 24th SCLK rising edge when SEN is low. If the word length exceeds a multiple of 24 bits, the excess bits are ignored. Data can be loaded in multiples of 24-bit words within a single active SEN pulse (an internal counter counts groups of 24 clocks after the SEN falling edge). The interface can function with SCLK frequencies from 20 MHz down to low speeds (of a few Hertz) and even with a non-50% duty cycle SCLK. Data are divided into two main portions to load on the addressed register: a register address (eight bits) and the actual data (16 bits). When writing to a register with unused bits, these bits should be set to '0'. Figure 18 shows a timing diagram of the write operation. Table 3 lists the serial interface timing characteristics.

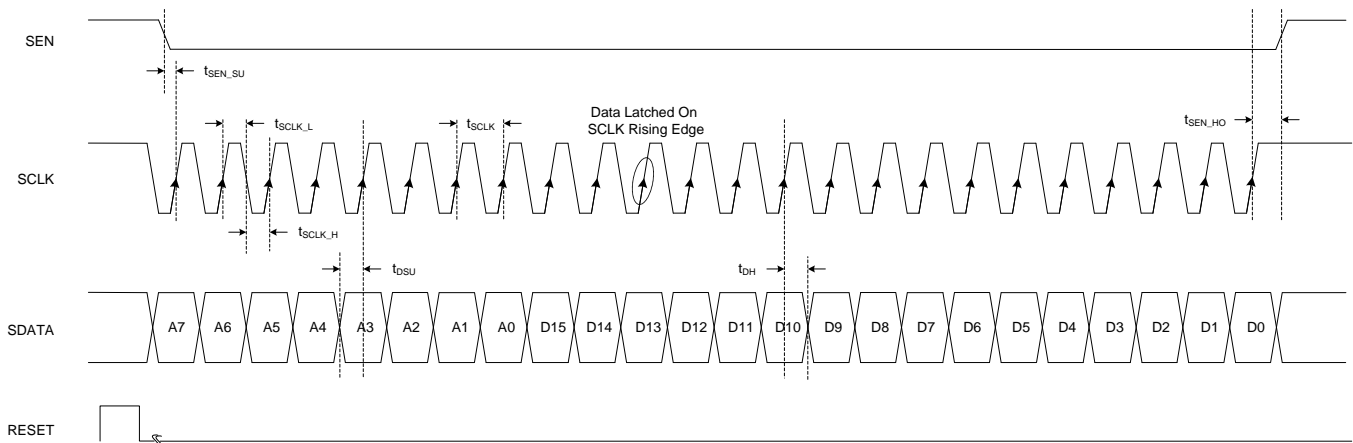

Figure 18. Serial Interface Timing Diagram

Table 3. Serial Interface Timing Characteristics⁽¹⁾

PARAMETER		MIN	TYP	MAX	UNIT
t_{SCLK}	SCLK period	50			ns
t_{SCLK_H}	SCLK high time	20			ns
t_{SCLK_L}	SCLK low time	20			ns
t_{DSU}	Data setup time	5			ns
t_{DHO}	Data hold time	5			ns
t_{SEN_SU}	SEN falling edge to SCLK rising edge	8			ns
t_{SEN_HO}	Time between last SCLK rising edge to SEN rising edge	8			ns
$t_{OUT_DV}^{(2)}$	Delay from SCLK falling edge to SDOOUT valid	12	20	28	ns

(1) Minimum values are across the full temperature range of $T_{MIN} = -40^{\circ}\text{C}$ to $T_{MAX} = +85^{\circ}\text{C}$ and $AVDD = 3.3\text{ V}$.

(2) See Figure 19.

REGISTER READOUT

The device includes an option where the contents of the internal registers can be read back. This readout may be useful as a diagnostic test to verify the serial interface communication between the external controller and the AFE. First, the REGISTER READOUT ENABLE bit (bit 1, register 00h) must be set to '1'. Then, initiate a serial interface cycle specifying the register address (A[7:0]) to be read. The data bits are *don't care*. The device outputs the contents (D[15:0]) of the selected register on the SDOUT pin. SDOUT has a typical 20-ns delay (t_{OUT_DV}) from the SCLK falling edge. For a lower speed SCLK, SDOUT can be latched on the SCLK rising edge. For a higher speed SCLK (for example, with an SCLK period less than 60 ns), latching SDOUT at the next SCLK falling edge is preferable. Figure 19 shows the read operation timing diagram (timing specifications follow the same information provided in Table 3). In readout mode, REGISTER READOUT ENABLE can still be accessed through SDATA, SCLK, and SEN. To enable serial register writes, set the REGISTER READOUT ENABLE bit back to '0'.

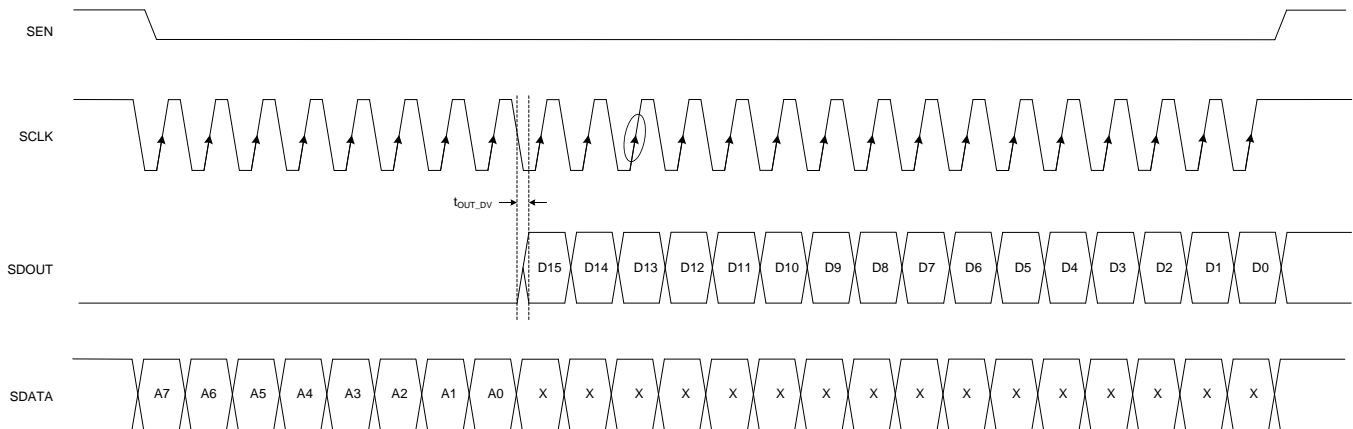

Figure 19. Serial Interface Register Read Timing Diagram

REGISTER MAP

A reset process is required at the device initialization stage. Initialization can be accomplished in one of two ways:

1. Through a hardware reset, by applying a positive pulse on the RESET pin, or
2. Through a software reset (using the serial interface), by setting the SW_RESET bit high. Setting this bit initializes the internal registers to the respective default values (all '0's) and then self-resets the SW_RESET bit low. In this case, the RESET pin can remain low (inactive).

After reset, all PGA registers are set to '0' (default). During register programming, all reserved or unlisted register bits must be set to '0'. Register settings are maintained when the device is in either partial or complete power-down mode. [Table 4](#) lists the PGA register map.

Table 4. PGA Register Map

REGISTER (Hex)	DECIMAL VALUE	Bit 15	BIT 14	BIT 13	BIT 12	BIT 11	BIT 10	BIT 9	BIT 8	BIT 7	BIT 6	BIT 5	BIT 4	BIT 3	BIT 2	BIT 1	BIT 0
00	0	X ⁽¹⁾	X	X	X	X	X	X	X	X	X	X	X	X	X	REGISTER READOUT ENABLE ⁽²⁾	SW_RESET
35	53	COMPLETE PDN	PARTIAL PDN	X	X	X	X	X	X	X	X	X	X	X	X	X	X
3B	59	X	X	X	X	X	X	X	X	LOW_FILTER_BW	PGA_GAIN		X	X	X	X	

(1) X = don't care.

(2) Shaded cells indicate used bits.

Register Descriptions
Table 5. Register 00h

15	14	13	12	11	10	9	8
X	X	X	X	X	X	X	X
7	6	5	4	3	2	1	0
X	X	X	X	X	X	REGISTER READOUT ENABLE	SW_RESET

Bits 15:2 **Don't care**

Default = 0.

Bit 1 **REGISTER READOUT ENABLE**

0 = Readout disabled (default)

1 = Register readout enabled at SDOOUT pin

Bit 0 **SW_RESET**

0 = Normal operation (default)

1 = Resets the device and self-clears the bit to '0'

Table 6. Register 35h

15	14	13	12	11	10	9	8
COMPLETE PDN	PARTIAL PDN	X	X	X	X	X	X
7	6	5	4	3	2	1	0
X	X	X	X	X	X	X	X

Bit 15 **COMPLETE PDN**

Bit 14 **PARTIAL PDN**

0 = Normal operation (default)

1 = LNA and PGA powered down

Bits 13:0 **Don't care**

Default = 0.

Table 7. Register 3Bh

15	14	13	12	11	10	9	8
X	X	X	X	X	X	X	X
7	6	5	4	3	2	1	0
LOW_FILTER_ BW	PGA_GAIN			X	X	X	X

Bits 15:8**Don't care**

Default = 0.

Bit 7**LOW_FILTER_BW**

0 = 75-MHz bandwidth (default)

1 = 60-MHz bandwidth

Bits 6:4**PGA_GAIN**

000 = 18-dB PGA gain (default)

001 = 15-dB PGA gain

010 = 12-dB PGA gain

011 = 9-dB PGA gain

100 = 6-dB PGA gain

101 = 3-dB PGA gain

110 = 0-dB PGA gain

Bits 3:0**Don't care**

Default = 0.

APPLICATION INFORMATION

THEORY OF OPERATION

The PGA5807 is a programmable gain amplifier (PGA) for applications with input frequencies up to 25 MHz. The device includes a low-noise amplifier (LNA) with a fixed gain, followed by a PGA and an antialiasing filter to reduce noise. The LNA is a fully-differential amplifier with a 12-dB fixed gain and can support a 500-mV_{PP} maximum linear differential input swing. The PGA is implemented as an attenuator followed by a fixed-gain amplifier with 18-dB gain. The attenuator can provide attenuation from 0 dB to –18 dB in 3-dB steps. The attenuator can be controlled by the GAIN[2:0] pins or by using register 3Bh (bits 6 to 4). The antialiasing filter is combined with the fixed-gain amplifier. The filter has one active pole and a passive pole for a combined bandwidth of 75 MHz. For low-frequency applications, bandwidth can be reduced to 60 MHz where better noise can be achieved. The device can be programmed in this mode either by using the SDATA pin while RESET is high or by using bit 7 of register 3Bh. This device can directly drive ADCs such as the [ADS5296](#).

Low-Noise Amplifier (LNA)

In most data-acquisition systems, an LNA is required at the front-end to obtain good noise performance. The PGA5807 has a fully-differential LNA with a 12-dB fixed gain. The LNA input-referred noise is 1.9 nV/√Hz, and supports a differential 500-mV_{PP} input swing. The LNA input can be applied either directly or through an ac-coupling capacitor. Internally, the LNA input is connected to a 2.1-V common-mode voltage via a large resistor (8 kΩ). For direct input coupling, the LNA supports an input common-mode range from 1.9 V to 2.3 V. The LNA input circuits are shown in [Figure 20](#).

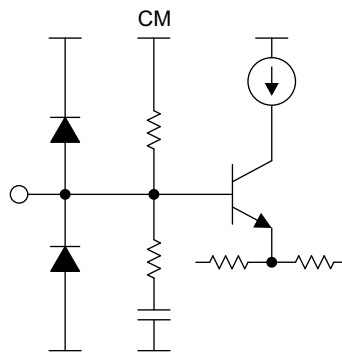

Figure 20. INP and INM Equivalent Circuits of LNA Inputs

Programmable Gain Amplifier (PGA) and Filter

The LNA output is transmitted to a PGA with a programmable gain from 0 dB to 18 dB in 3-dB steps. This gain can either be controlled through a serial interface or through pins, as explained in the [Serial Register Write Description](#) section. The PGA is implemented as a programmable attenuator and as a fixed-gain amplifier with an 18-dB gain. This architecture helps achieve the same bandwidth across different gain settings. The attenuator provides programmable attenuation from 0 dB to 18 dB.

The attenuator architecture is shown in [Figure 21](#). There are six shunt resistors that can be connected or disconnected to achieve programmable attenuation. The network provides 0-dB attenuation when no shunt resistors are connected. When the first shunt resistor (RS_1) is turned on, an attenuation of 3 dB is obtained. For achieving 6-dB attenuation, both RS_1 and RS_2 are turned on. Similarly, by turning on additional resistors, greater attenuation can be achieved; by turning on all resistors, an effective 18-dB attenuation is achieved.

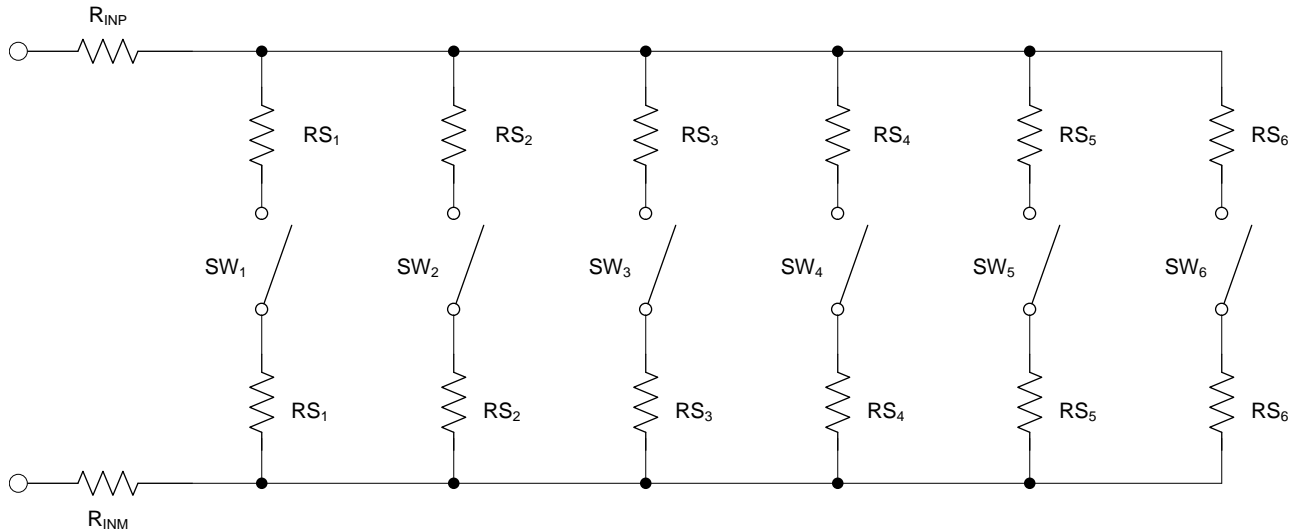

Figure 21. Programmable Attenuator

The attenuator is followed by a 18-dB fixed-gain amplifier. The amplifier is implemented as a voltage-to-current (V-to-I) converter followed by a current-to-voltage (I-to-V) converter. The I-to-V bandwidth is limited so that it functions as an LPF and is followed by a passive filter, as shown in Figure 22. Both the active and passive filters provide an antialiasing filter action, which helps reduce noise when the PGA output is sampled by an ADC. The architecture of the passive filter is selected to reduce the glitches that can occur when the PGA5807 output is sampled by an ADC. For example, the PGA5807 can be directly connected to ADC devices (such as the ADS5295 or ADS5296) without any external components between the ADC and PGA5807. Figure 23 shows an example of the PGA5807 connected directly to the ADS5296.

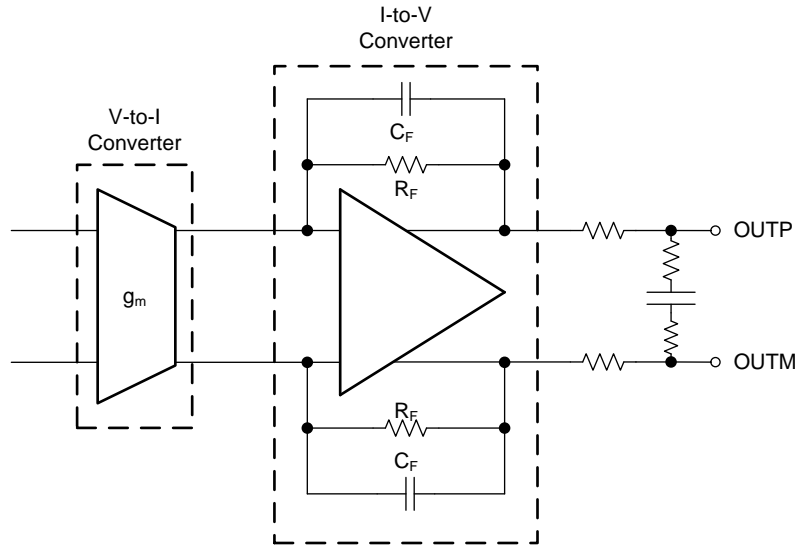

Figure 22. Antialias Filter

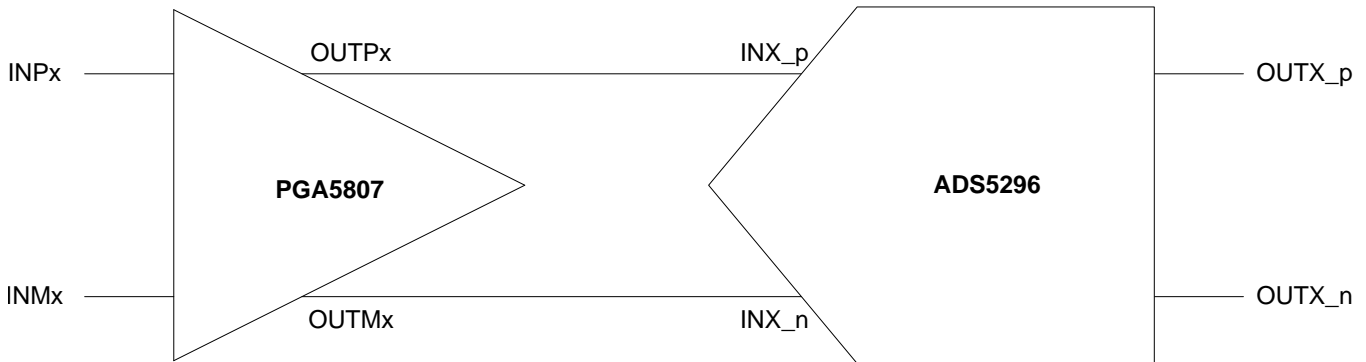

Figure 23. PGA Connected to an ADC

DEVICE CONFIGURATION USING SERIAL INTERFACE OR PARALLEL PINS

Different device modes (such as channel gain and bandwidth) can be programmed by either using the serial interface or external pins. The device can be configured via the serial interface only when the device RESET pin is pulsed and remains low. In this configuration, device gain can be programmed through register 3Bh (bits 6 to 4) and bandwidth can be programmed by register 3Bh (bit 7). When the RESET pin is connected to 3.3 V or is pulled high, the serial interface is unable to control the device. In this configuration, the GAIN[2:0] pins can be used to control gain and the SDATA pin can be used to control bandwidth.

REVISION HISTORY

NOTE: Page numbers for previous revisions may differ from page numbers in the current version.

Changes from Revision A (June 2013) to Revision B **Page**

- Deleted *Body Scan Imaging* bullet from Applications section 1
-

Changes from Original (May 2013) to Revision A **Page**

- Moved to Production Data 1
-

PACKAGING INFORMATION

Orderable Device	Status (1)	Package Type	Package Drawing	Pins	Package Qty	Eco Plan (2)	Lead/Ball Finish	MSL Peak Temp (3)	Op Temp (°C)	Device Marking (4/5)	Samples
PGA5807RGCR	ACTIVE	VQFN	RGC	64	2000	Green (RoHS & no Sb/Br)	CU NIPDAU	Level-3-260C-168 HR	-40 to 85	PGA5807	Samples
PGA5807RGCT	ACTIVE	VQFN	RGC	64	250	Green (RoHS & no Sb/Br)	CU NIPDAU	Level-3-260C-168 HR	-40 to 85	PGA5807	Samples

(1) The marketing status values are defined as follows:

ACTIVE: Product device recommended for new designs.

LIFEBUY: TI has announced that the device will be discontinued, and a lifetime-buy period is in effect.

NRND: Not recommended for new designs. Device is in production to support existing customers, but TI does not recommend using this part in a new design.

PREVIEW: Device has been announced but is not in production. Samples may or may not be available.

OBSOLETE: TI has discontinued the production of the device.

(2) Eco Plan - The planned eco-friendly classification: Pb-Free (RoHS), Pb-Free (RoHS Exempt), or Green (RoHS & no Sb/Br) - please check <http://www.ti.com/productcontent> for the latest availability information and additional product content details.

TBD: The Pb-Free/Green conversion plan has not been defined.

Pb-Free (RoHS): TI's terms "Lead-Free" or "Pb-Free" mean semiconductor products that are compatible with the current RoHS requirements for all 6 substances, including the requirement that lead not exceed 0.1% by weight in homogeneous materials. Where designed to be soldered at high temperatures, TI Pb-Free products are suitable for use in specified lead-free processes.

Pb-Free (RoHS Exempt): This component has a RoHS exemption for either 1) lead-based flip-chip solder bumps used between the die and package, or 2) lead-based die adhesive used between the die and leadframe. The component is otherwise considered Pb-Free (RoHS compatible) as defined above.

Green (RoHS & no Sb/Br): TI defines "Green" to mean Pb-Free (RoHS compatible), and free of Bromine (Br) and Antimony (Sb) based flame retardants (Br or Sb do not exceed 0.1% by weight in homogeneous material)

(3) MSL, Peak Temp. -- The Moisture Sensitivity Level rating according to the JEDEC industry standard classifications, and peak solder temperature.

(4) There may be additional marking, which relates to the logo, the lot trace code information, or the environmental category on the device.

(5) Multiple Device Markings will be inside parentheses. Only one Device Marking contained in parentheses and separated by a "~" will appear on a device. If a line is indented then it is a continuation of the previous line and the two combined represent the entire Device Marking for that device.

Important Information and Disclaimer: The information provided on this page represents TI's knowledge and belief as of the date that it is provided. TI bases its knowledge and belief on information provided by third parties, and makes no representation or warranty as to the accuracy of such information. Efforts are underway to better integrate information from third parties. TI has taken and continues to take reasonable steps to provide representative and accurate information but may not have conducted destructive testing or chemical analysis on incoming materials and chemicals. TI and TI suppliers consider certain information to be proprietary, and thus CAS numbers and other limited information may not be available for release.

In no event shall TI's liability arising out of such information exceed the total purchase price of the TI part(s) at issue in this document sold by TI to Customer on an annual basis.

TAPE AND REEL INFORMATION



QUADRANT ASSIGNMENTS FOR PIN 1 ORIENTATION IN TAPE



*All dimensions are nominal

Device	Package Type	Package Drawing	Pins	SPQ	Reel Diameter (mm)	Reel Width W1 (mm)	A0 (mm)	B0 (mm)	K0 (mm)	P1 (mm)	W (mm)	Pin1 Quadrant
PGA5807RGCR	VQFN	RGC	64	2000	330.0	16.4	9.3	9.3	1.5	12.0	16.0	Q2
PGA5807RGCT	VQFN	RGC	64	250	330.0	16.4	9.3	9.3	1.5	12.0	16.0	Q2

TAPE AND REEL BOX DIMENSIONS

*All dimensions are nominal

Device	Package Type	Package Drawing	Pins	SPQ	Length (mm)	Width (mm)	Height (mm)
PGA5807RGCR	VQFN	RGC	64	2000	336.6	336.6	28.6
PGA5807RGCT	VQFN	RGC	64	250	336.6	336.6	28.6

MECHANICAL DATA

RGC(S-PVQFN-N64) CUSTOM DEVICE PLASTIC QUAD FLATPACK NO-LEAD

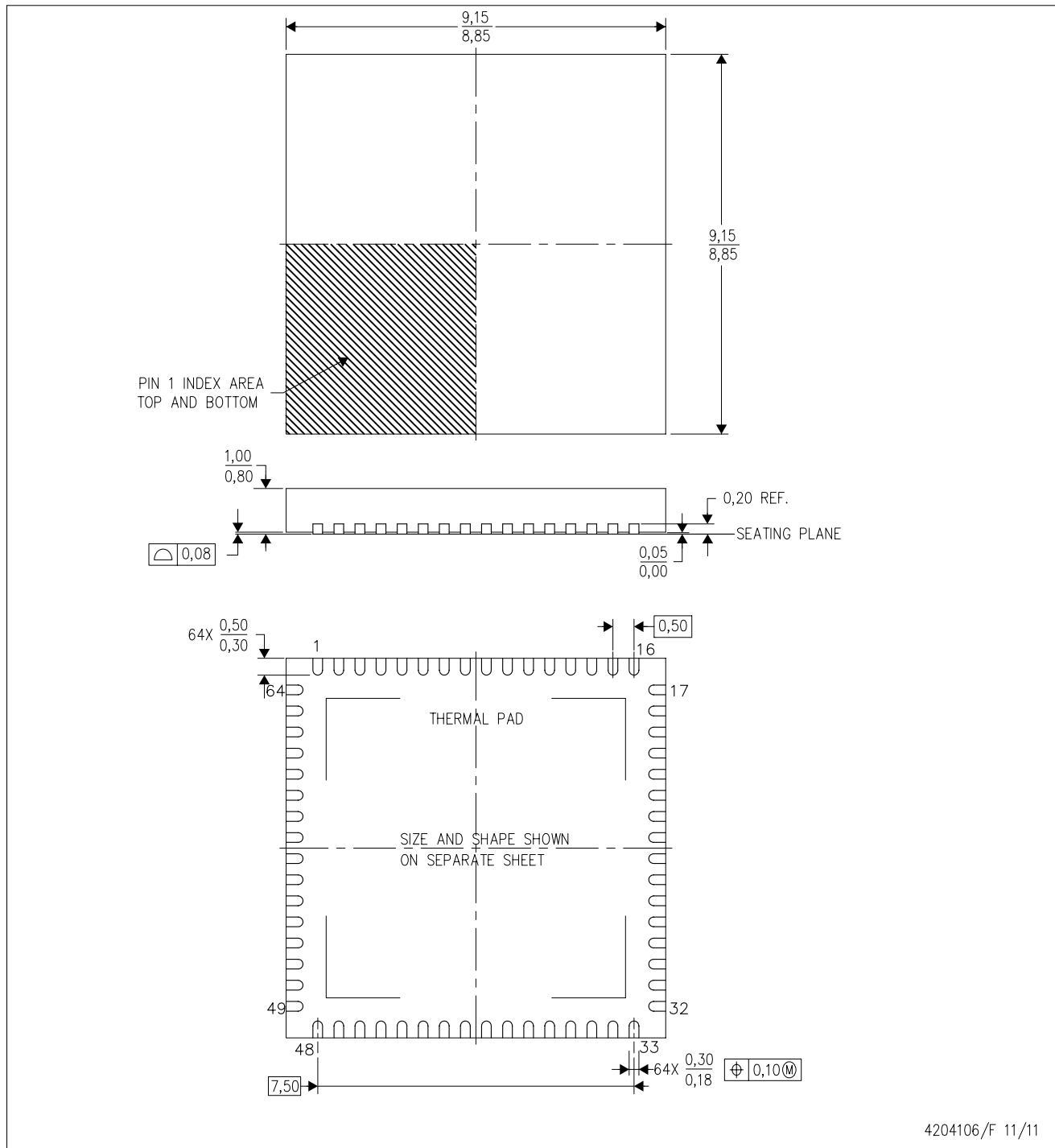

- NOTES:
- All linear dimensions are in millimeters. Dimensioning and tolerancing per ASME Y14.5-1994.
 - This drawing is subject to change without notice.
 - Quad Flatpack, No-leads (QFN) package configuration.
 - The package thermal pad must be soldered to the board for thermal and mechanical performance.
 - See the additional figure in the Product Data Sheet for details regarding the exposed thermal pad features and dimensions.

THERMAL PAD MECHANICAL DATA

RGC (S-PVQFN-N64)

PLASTIC QUAD FLATPACK NO-LEAD

THERMAL INFORMATION

This package incorporates an exposed thermal pad that is designed to be attached directly to an external heatsink. The thermal pad must be soldered directly to the printed circuit board (PCB). After soldering, the PCB can be used as a heatsink. In addition, through the use of thermal vias, the thermal pad can be attached directly to the appropriate copper plane shown in the electrical schematic for the device, or alternatively, can be attached to a special heatsink structure designed into the PCB. This design optimizes the heat transfer from the integrated circuit (IC).

For information on the Quad Flatpack No-Lead (QFN) package and its advantages, refer to Application Report, QFN/SON PCB Attachment, Texas Instruments Literature No. SLUA271. This document is available at www.ti.com.

The exposed thermal pad dimensions for this package are shown in the following illustration.

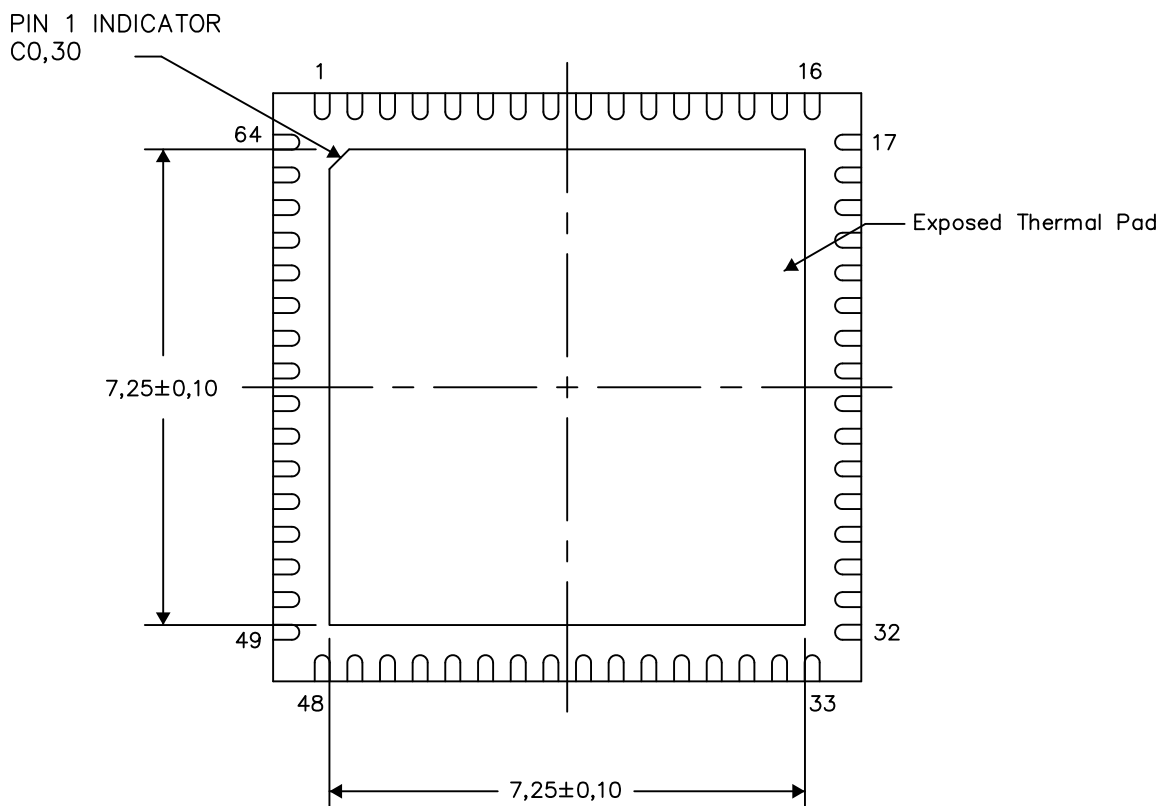

Bottom View

Exposed Thermal Pad Dimensions

4206192-2/Z 05/13

NOTE: A. All linear dimensions are in millimeters

RGC (S-PVQFN-N64)

PLASTIC QUAD FLATPACK NO-LEAD

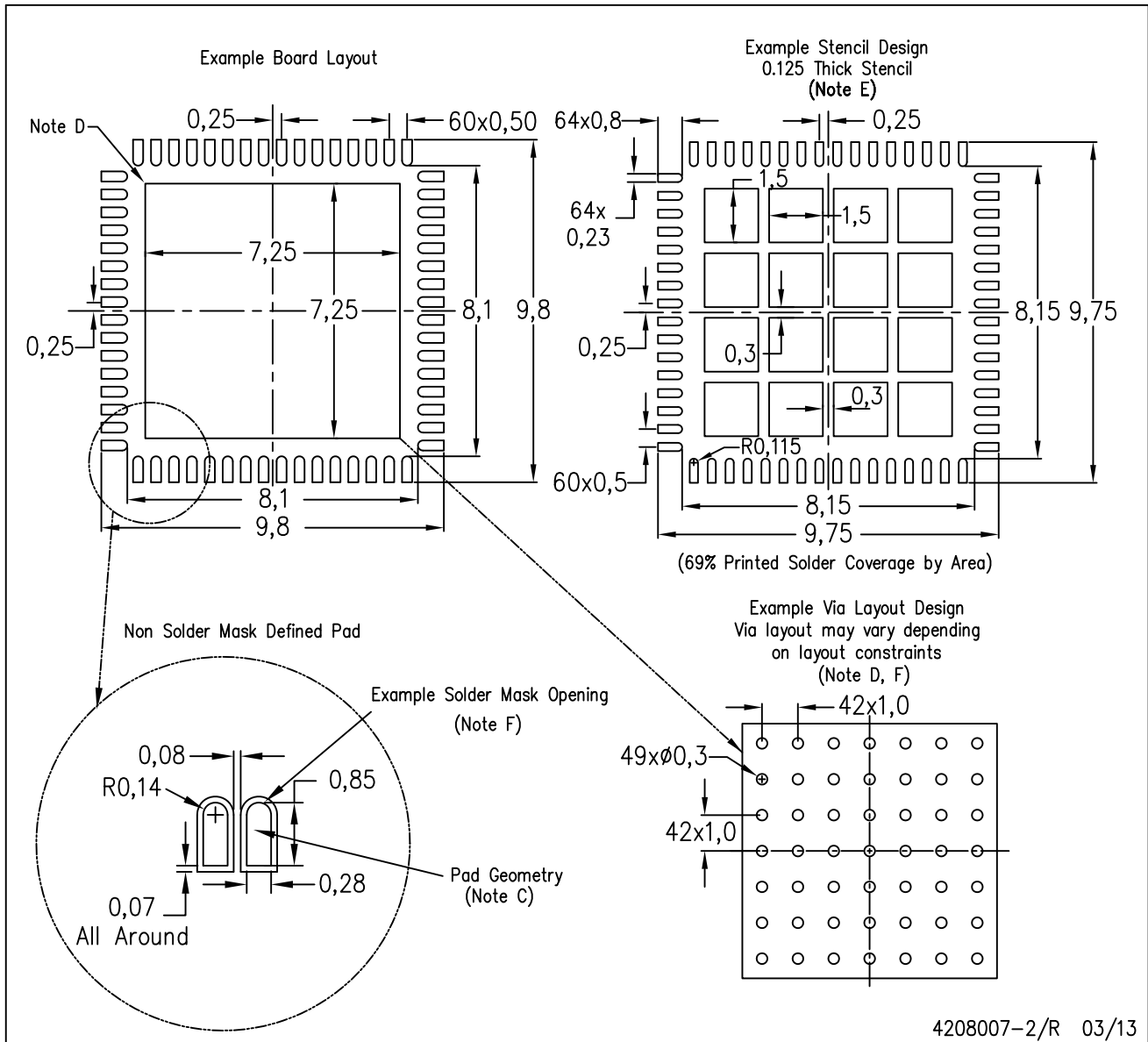

- NOTES:
- A. All linear dimensions are in millimeters.
 - B. This drawing is subject to change without notice.
 - C. Publication IPC-7351 is recommended for alternate designs.
 - D. This package is designed to be soldered to a thermal pad on the board. Refer to Application Note, Quad Flat-Pack Packages, Texas Instruments Literature No. SLUA271, and also the Product Data Sheets for specific thermal information, via requirements, and recommended board layout. These documents are available at www.ti.com <<http://www.ti.com>>.
 - E. Laser cutting apertures with trapezoidal walls and also rounding corners will offer better paste release. Customers should contact their board assembly site for stencil design recommendations. Refer to IPC 7525 for stencil design considerations.
 - F. Customers should contact their board fabrication site for recommended solder mask tolerances and via tenting recommendations for vias placed in thermal pad.

IMPORTANT NOTICE

Texas Instruments Incorporated and its subsidiaries (TI) reserve the right to make corrections, enhancements, improvements and other changes to its semiconductor products and services per JESD46, latest issue, and to discontinue any product or service per JESD48, latest issue. Buyers should obtain the latest relevant information before placing orders and should verify that such information is current and complete. All semiconductor products (also referred to herein as "components") are sold subject to TI's terms and conditions of sale supplied at the time of order acknowledgment.

TI warrants performance of its components to the specifications applicable at the time of sale, in accordance with the warranty in TI's terms and conditions of sale of semiconductor products. Testing and other quality control techniques are used to the extent TI deems necessary to support this warranty. Except where mandated by applicable law, testing of all parameters of each component is not necessarily performed.

TI assumes no liability for applications assistance or the design of Buyers' products. Buyers are responsible for their products and applications using TI components. To minimize the risks associated with Buyers' products and applications, Buyers should provide adequate design and operating safeguards.

TI does not warrant or represent that any license, either express or implied, is granted under any patent right, copyright, mask work right, or other intellectual property right relating to any combination, machine, or process in which TI components or services are used. Information published by TI regarding third-party products or services does not constitute a license to use such products or services or a warranty or endorsement thereof. Use of such information may require a license from a third party under the patents or other intellectual property of the third party, or a license from TI under the patents or other intellectual property of TI.

Reproduction of significant portions of TI information in TI data books or data sheets is permissible only if reproduction is without alteration and is accompanied by all associated warranties, conditions, limitations, and notices. TI is not responsible or liable for such altered documentation. Information of third parties may be subject to additional restrictions.

Resale of TI components or services with statements different from or beyond the parameters stated by TI for that component or service voids all express and any implied warranties for the associated TI component or service and is an unfair and deceptive business practice. TI is not responsible or liable for any such statements.

Buyer acknowledges and agrees that it is solely responsible for compliance with all legal, regulatory and safety-related requirements concerning its products, and any use of TI components in its applications, notwithstanding any applications-related information or support that may be provided by TI. Buyer represents and agrees that it has all the necessary expertise to create and implement safeguards which anticipate dangerous consequences of failures, monitor failures and their consequences, lessen the likelihood of failures that might cause harm and take appropriate remedial actions. Buyer will fully indemnify TI and its representatives against any damages arising out of the use of any TI components in safety-critical applications.

In some cases, TI components may be promoted specifically to facilitate safety-related applications. With such components, TI's goal is to help enable customers to design and create their own end-product solutions that meet applicable functional safety standards and requirements. Nonetheless, such components are subject to these terms.

No TI components are authorized for use in FDA Class III (or similar life-critical medical equipment) unless authorized officers of the parties have executed a special agreement specifically governing such use.

Only those TI components which TI has specifically designated as military grade or "enhanced plastic" are designed and intended for use in military/aerospace applications or environments. Buyer acknowledges and agrees that any military or aerospace use of TI components which have **not** been so designated is solely at the Buyer's risk, and that Buyer is solely responsible for compliance with all legal and regulatory requirements in connection with such use.

TI has specifically designated certain components as meeting ISO/TS16949 requirements, mainly for automotive use. In any case of use of non-designated products, TI will not be responsible for any failure to meet ISO/TS16949.

Products

Audio	www.ti.com/audio
Amplifiers	amplifier.ti.com
Data Converters	dataconverter.ti.com
DLP® Products	www.dlp.com
DSP	dsp.ti.com
Clocks and Timers	www.ti.com/clocks
Interface	interface.ti.com
Logic	logic.ti.com
Power Mgmt	power.ti.com
Microcontrollers	microcontroller.ti.com
RFID	www.ti-rfid.com
OMAP Applications Processors	www.ti.com/omap
Wireless Connectivity	www.ti.com/wirelessconnectivity

Applications

Automotive and Transportation	www.ti.com/automotive
Communications and Telecom	www.ti.com/communications
Computers and Peripherals	www.ti.com/computers
Consumer Electronics	www.ti.com/consumer-apps
Energy and Lighting	www.ti.com/energy
Industrial	www.ti.com/industrial
Medical	www.ti.com/medical
Security	www.ti.com/security
Space, Avionics and Defense	www.ti.com/space-avionics-defense
Video and Imaging	www.ti.com/video

TI E2E Community

e2e.ti.com

Looking for pricing, stock, or lifecycle information?

Click below to explore more details on WIN SOURCE:

 [View PGA5807RGCR on WIN SOURCE](#)

 [Texas Instruments](#) Information

Optimize Your Supply Chain with WIN SOURCE Solutions

-  Global Sourcing Solution
-  Obsolete Management
-  Cost Control Management
-  Shortage Management
-  Alternative Solution
-  Excess Inventory Management