



**THE DATASHEET OF  
PGA-1021+**





ULTRA HIGH DYNAMIC RANGE

# Monolithic Amplifier

## PGA-1021+

Mini-Circuits

50Ω 0.05 to 6 GHz

### THE BIG DEAL

- 3.3V, 57mA operation
- High IP3, 26.7 dBm typ. at 2 GHz
- Gain, 13.4 dB typ. at 2 GHz
- P1dB 16.9 dBm typ. at 2 GHz
- Low noise figure, 2.4dB @2 GHz
- No external matching components required

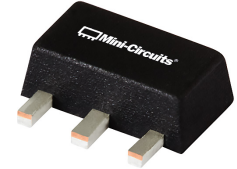

Generic photo used for illustration purposes only

CASE STYLE: DF782

**+RoHS Compliant**

The +Suffix identifies RoHS Compliance. See our web site for RoHS Compliance methodologies and qualifications

### APPLICATIONS

- Base station infrastructure
- Portable Wireless
- CATV & DBS
- MMDS & Wireless LAN
- LTE

### PRODUCT OVERVIEW

PGA-1021+ (RoHS compliant) is an advanced wideband amplifier fabricated using E-PHEMT technology and offers extremely high dynamic range over a broad frequency range and with low noise figure. In addition, the PGA-1021+ has good input and output return loss over a broad frequency range without the need for external matching components and has demonstrated excellent reliability. Lead finish is SnAgNi. It has repeatable performance from lot to lot and is enclosed in a SOT-89 package for very good thermal performance.

### KEY FEATURES

Feature	Advantages
Broad Band: 0.05 to 6.0 GHz	Broadband covering primary wireless communications bands: Cellular, PCS, LTE, WiMAX
High IP3 Versus DC power Consumption: 26.7 dBm typical at 2 GHz at +3.3V Supply Voltage and only 83mA	The PGA-1021+ provides good IP3 performance relative to device size and power consumption. The combination of the design and E-PHEMT Structure provides enhanced linearity over a broad frequency range as evidence in the IP3 being typically 15 dB above the P 1dB point. This feature makes this amplifier ideal for use in: <ul style="list-style-type: none"> <li>• Driver amplifiers for complex waveform up converter paths</li> <li>• Drivers in linearized transmit systems</li> <li>• Secondary amplifiers in ultra High Dynamic range receivers</li> </ul>
*No External Matching Components Required	Unlike competing products, Mini-Circuits PGA-1021+ provides Input and Output Return Loss of 15-21 dB up to 4 GHz without the need for any external matching components. However, an external resistor, R1=2.37kΩ is used for biasing (See Figure 2)
Low Noise Figure: 2.3 dB up to 0.8 GHz	A unique feature of the PGA-1021+ which separates this design from all competitors is the low noise figure performance in combination with the high dynamic range.

REV. C  
ECO-011959  
PGA-1021+  
TH/RS/CP  
220208





ULTRA HIGH DYNAMIC RANGE

# Monolithic Amplifier

## PGA-1021+

Mini-Circuits

### ELECTRICAL SPECIFICATIONS<sup>(1)</sup> AT 25°C, 50Ω AND 3.3V, UNLESS NOTED OTHERWISE

Parameter	Condition (GHz)	Min.	Typ.	Max.	Units
Frequency Range		0.05		6	GHz
Gain	0.05	—	16.9	—	dB
	0.8	13.6	15.1	17.2	
	2.0	—	13.4	—	
	3.0	—	11.9	—	
	4.0	—	11.0	—	
	6.0	—	9.8	—	
Input Return Loss	0.05	—	12.1	—	dB
	0.8	13.0	16.6	—	
	2.0	—	11.7	—	
	3.0	—	9.8	—	
	4.0	—	8.6	—	
	6.0	—	6.2	—	
Output Return Loss	0.05	—	15.5	—	dB
	0.8	18.0	25.4	—	
	2.0	—	19.3	—	
	3.0	—	16.4	—	
	4.0	—	14.5	—	
	6.0	—	10.6	—	
Reverse Isolation	2.0		21.2		dB
Output Power @1 dB compression	0.05	—	16.8	—	dBm
	0.8	14.8	16.8	—	
	2.0	—	16.9	—	
	3.0	—	16.9	—	
	4.0	—	16.6	—	
	6.0	—	15.9	—	
Output IP3	0.05		26.3		dBm
	0.8		26.5		
	2.0		26.7		
	3.0		27.0		
	4.0		27.7		
	6.0		27.3		
Noise Figure	0.05		2.1		dB
	0.8		2.3		
	2.0		2.4		
	3.0		2.9		
	4.0		3.1		
	6.0		3.8		
Device Operating Voltage		3.1	3.3	3.5	V
Device Operating Current		37	57	90	mA
Device Current Variation vs. Temperature			29		μA/°C
Device Current Variation vs Voltage			0.066		mA/mV
Thermal Resistance, junction-to-ground lead			73		°C/W

(1) Measured on Mini-Circuits Characterization test board TB-313 with external biasing resistor (2.37kΩ) and Bias-Tee. See Characterization Test Circuit (Fig. 1)

### MAXIMUM RATINGS

Parameter	Ratings
Operating Temperature (ground lead)	-40°C to 85°C
Storage Temperature	-65°C to 150°C
Operating Current at 3.3V	300 mA
Power Dissipation	1.0 W
Input Power (CW)	28 dBm
DC Voltage on Pin 3	5.5 V

Permanent damage may occur if any of these limits are exceeded. Electrical maximum ratings are not intended for continuous normal operation.





### SIMPLIFIED SCHEMATIC AND PIN DESCRIPTION

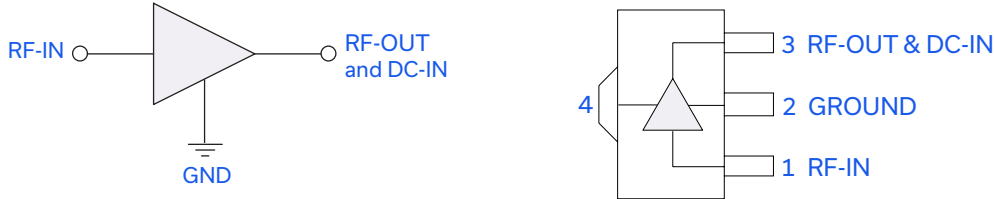

Function	Pin Number	Description
RF-IN	1	RF input pin. This pin requires the use of an external DC blocking capacitor chosen for the frequency of operation.
RF-OUT and DC-IN	3	RF output and bias pin. DC voltage is present on this pin; therefore a DC blocking capacitor is necessary for proper operation. An RF choke is needed to feed DC bias without loss of RF signal due to the bias connection, as shown in "Recommended Application Circuit", Fig. 2
GND	2,4	Connections to ground. Use via holes as shown in "Suggested Layout for PCB Design" to reduce ground path inductance for best performance.

### CHARACTERIZATION TEST CIRCUIT

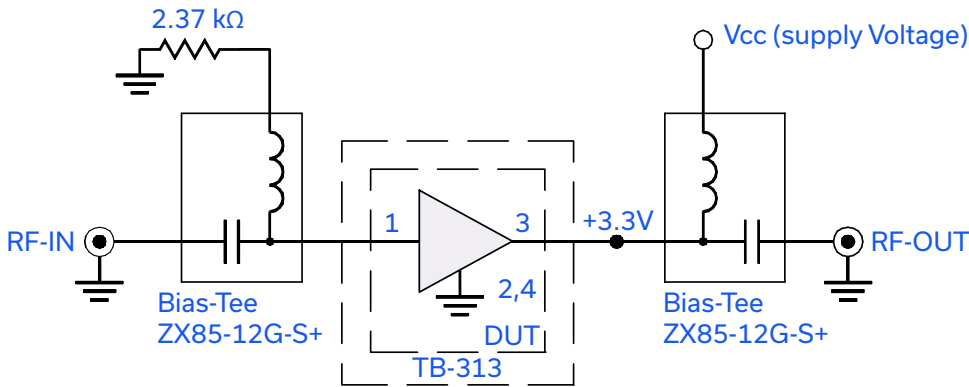

Fig 1. Block Diagram of Test Circuit used for characterization. (DUT tested on Mini-Circuits Characterization test board TB-313)

Gain, Return loss, Output power at 1dB compression (P1 dB) , output IP3 (OIP3) and noise figure measured using Agilent's N5242A PNA-X microwave network analyzer.

Conditions:

1. Gain and Return loss: Pin= -25dBm
2. Output IP3 (OIP3): Two tones, spaced 10 MHz apart, 0 dBm/tone at output.



### RECOMMENDED APPLICATION CIRCUIT

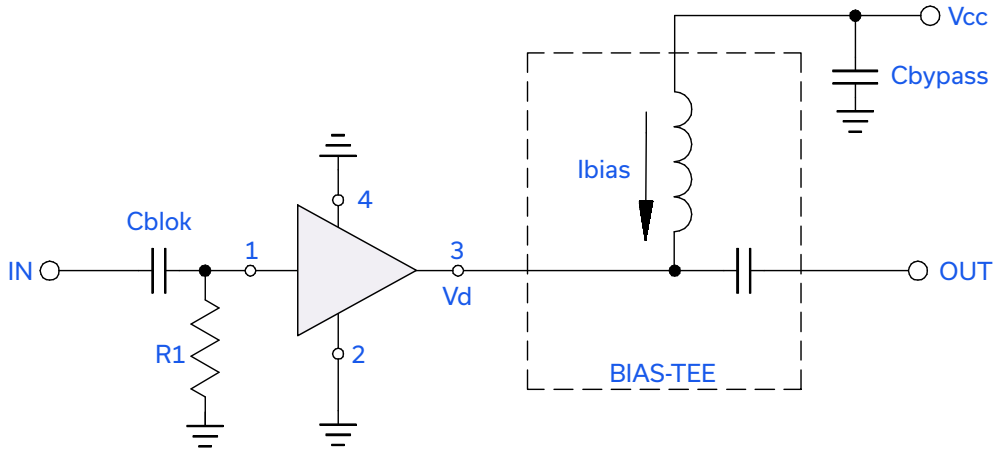

R1=2.37k $\Omega$ , Cblock=0.001 $\mu$ F, Bias-Tee=TCBT-14+, Cbypass=0.1 $\mu$ F

Fig 2. Evaluation board includes case, connectors, and components soldered to PCB

### PRODUCT MARKING

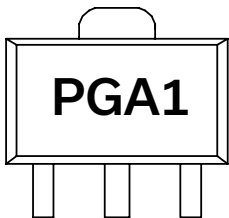

Marking may contain other features or characters for internal lot control



ADDITIONAL DETAILED TECHNICAL INFORMATION IS AVAILABLE ON OUR DASH BOARD. TO ACCESS [CLICK HERE](#)

Performance Data	Data Table Swept Graphs S-Parameter (S2P Files) Data Set (.zip file)
Case Style	DF782 (SOT 89) Plastic package, exposed paddle lead finish: tin-silver over nickel
Tape & Reel Standard quantities available on reel	F55 7" reels with 20, 50, 100, 200, 500 or 1K devices
Suggested Layout for PCB Design	PL-313
Evaluation Board	TB-596-2+
Environmental Ratings	ENV08T1

### ESD RATING

Human Body Model (HBM): Class 1B (500 to <1000V) in accordance with ANSI/ESD STM 5.1 - 2001  
Machine Model (MM): Class M1(50V) in accordance with ANSI/ESD STM5.2-1999

### MSL RATING

Moisture Sensitivity: MSL1 in accordance with IPC/JEDEC J-STD-020D



#### Attention

Observe precautions for handling electrostatic sensitive devices

### MSL TEST FLOW CHART

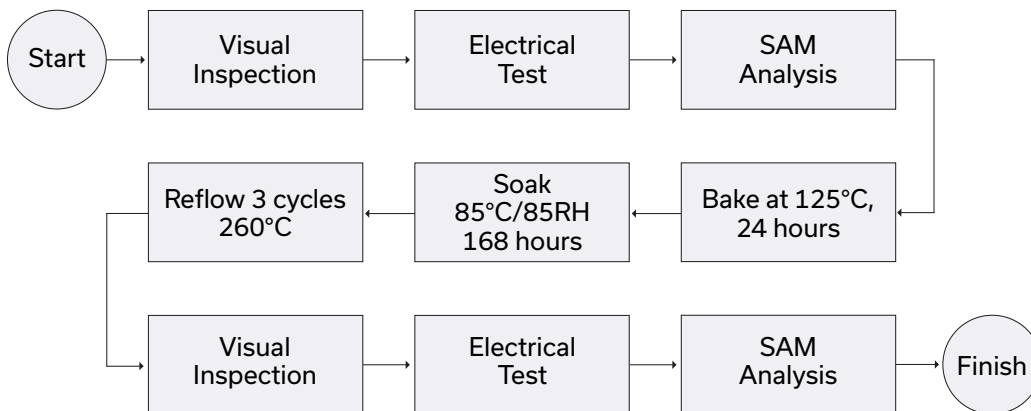

- NOTES**
- A. Performance and quality attributes and conditions not expressly stated in this specification document are intended to be excluded and do not form a part of this specification document.
  - B. Electrical specifications and performance data contained in this specification document are based on Mini-Circuit's applicable established test performance criteria and measurement instructions.
  - C. The parts covered by this specification document are subject to Mini-Circuits standard limited warranty and terms and conditions (collectively, "Standard Terms"); Purchasers of this part are entitled to the rights and benefits contained therein. For a full statement of the standard. Terms and the exclusive rights and remedies thereunder, please visit Mini-Circuits' website at [www.minicircuits.com/MCLStore/terms.jsp](http://www.minicircuits.com/MCLStore/terms.jsp)

## Looking for pricing, stock, or lifecycle information?

Click below to explore more details on WIN SOURCE:

 [View PGA-1021+ on WIN SOURCE](#)

 [Mini-Circuits Information](#)

## Optimize Your Supply Chain with WIN SOURCE Solutions

-  Global Sourcing Solution
-  Obsolete Management
-  Cost Control Management
-  Shortage Management
-  Alternative Solution
-  Excess Inventory Management