



**THE DATASHEET OF
YTM.U0M00.0**



PFE3000-12-069RA

3000 W AC-DC Front-End Power Supply

The **PFE3000-12-069RA** is a 3000 Watt AC/DC power-factor-corrected (PFC) and DC-DC power supply that converts standard AC mains power or high voltage DC bus voltages into a main output of 12 VDC for powering intermediate bus architectures (IBA) in high performance and reliability servers, routers, and network switches.

The PFE3000-12-069RA meets international safety standards and displays the CE-Mark for the European Low Voltage Directive (LVD).



Key Features & Benefits

- Best-in-class, Meet Platinum efficiency
- Wide input voltage range: 90-300 VAC
- AC input with power factor correction
- DC input voltage range: 192-400 VDC
- Hot-plug capable
- Parallel operation with active current sharing thru analog bus
- Full digital controls for improved performance
- High density design: 30.5 W/in³
- Small form factor: 555 x 69 x 42 mm (21.85 x 2.72 x 1.65 in)
- I2C communication interface with Power Management Bus protocol for monitoring, control, and firmware update via bootloader
- Overtemperature, output overvoltage and overcurrent protection
- RoHS Compliant
- 2 Status LEDs: AC OK and DC OK with fault signaling
- Safety-approved to IEC/EN 62368-1 and UL/CSA 62368-1.
- US Patent Pending

Applications

- High Performance Servers
- Routers
- Switches



1. ORDERING INFORMATION

PFE	3000	-	12	-	069	R	A	Option Code
Product Family	Power Level	Dash	V1 Output	Dash	Width	Airflow	Input	Blank: Standard model S366: Screw for Key-in feature is installed.
PFE Front-Ends	3000 W		12 V		69 mm	R: Reversed ¹	A: AC	

¹ Front to Rear

2. OVERVIEW

The PFE3000-12-069RA is a fully DSP controlled, highly efficient front-end power supply. It incorporates resonant-soft-switching technology and interleaved power trains to reduce component stresses, providing increased system reliability and very high efficiency. With a wide input operating voltage range and minimal linear derating of output power with respect to ambient temperature, the PFE3000-12-069RA maximizes power availability in demanding server, switch, and router applications. The power supply is fan cooled and ideally suited for server integration with a matching airflow path.

The PFC stage is digitally controlled using a state-of-the-art digital signal processing algorithm to guarantee best efficiency and unity power factor over a wide operating range.

The DC-DC stage uses soft switching resonant techniques in conjunction with synchronous rectification. An active OR-ing device on the output ensures no reverse load current and renders the supply ideally suited for operation in redundant power systems. The always-on +12V standby output provides power to external power distribution and management controllers. Its protection with an active OR-ing device provides for maximum reliability.

Status information is provided with front-panel LEDs. In addition, the power supply can be monitored and controlled (i.e. fan speed setpoint) via I²C communication interface with Power Management Bus protocol. It allows full monitoring of the supply, including input and output voltage, current, power, and inside temperatures. The same I²C bus supports the bootloader to allow field update of the firmware in the DSP controllers.

Cooling is managed by a fan, controlled by the DSP controller. The fan speed is adjusted automatically depending on the actual power demand and supply temperature and can be overridden through the I²C bus.

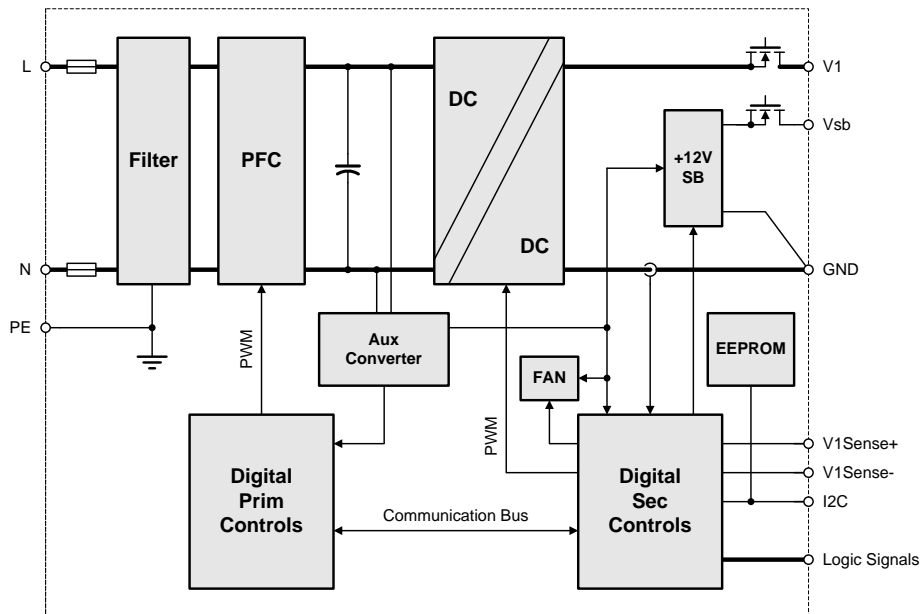

Figure 1 - PFE3000-12-069RA Block Diagram

3. ABSOLUTE MAXIMUM RATINGS

Stresses in excess of the absolute maximum ratings may cause performance degradation, adversely affect long-term reliability, and cause permanent damage to the supply.

PARAMETER	CONDITIONS / DESCRIPTION	MIN	MAX	UNITS
$V_{i\ maxc}$	Maximum Input		300	VAC

4. INPUT

General Condition: $T_A = 0 \dots 45\ ^\circ\text{C}$ unless otherwise noted.

PARAMETER	DESCRIPTION / CONDITION	MIN	NOM	MAX	UNIT
$V_{i\ nom}$	AC Nominal Input Voltage	100	230	277	VAC
V_i	AC Input Voltage Ranges	Normal operating ($V_{i\ min}$ to $V_{i\ max}$)		300	VAC
$V_{i\ nom\ DC}$	DC Nominal input voltage	240		380	VDC
$V_{i\ DC}$	DC Input voltage ranges	Normal operating ($V_{i\ min}$ to $V_{i\ max}$)		400	VDC
$V_{i\ red}$	Derated Input Voltage Range	See Figure 20 and Figure 33		180	VAC
$I_{i\ max}$	Max Input Current	$V_i > 200\ \text{VAC}, >100\ \text{VAC}$		17	A_{rms}
$I_{i\ p}$	Inrush Current Limitation	$V_{i\ min}$ to $V_{i\ max}, 0\ ^\circ\ T_{NTC} = 25^\circ\text{C}$ (Figure 5)		50	A_p
F_i	Input Frequency	47	50/60	63	Hz
PF	Power Factor	$V_{i\ nom}, 50\text{Hz}, > 0.3\ I_{i\ nom}$			W/VA
$V_{i\ on}$	Turn-on Input Voltage ²	Ramping up		87	VAC
$V_{i\ off}$	Turn-off Input Voltage ²	Ramping down		85	VAC
η	Efficiency without Fan	$V_{i\ nom}, 0.1 \cdot I_{x\ nom}, V_{x\ nom}, T_A = 25^\circ\text{C}$	90.0	91.85	%
		$V_{i\ nom}, 0.2 \cdot I_{x\ nom}, V_{x\ nom}, T_A = 25^\circ\text{C}$	93.0	94.40	
		$V_{i\ nom}, 0.5 \cdot I_{x\ nom}, V_{x\ nom}, T_A = 25^\circ\text{C}$	94.5	94.95	
		$V_{i\ nom}, I_{x\ nom}, V_{x\ nom}, T_A = 25^\circ\text{C}$	93.0	93.75	
T_{hold}	Hold-up Time	After last AC zero point, $V_i > 10.8\ \text{V}$, V_{SB} within regulation, $V_i = 230\ \text{VAC}, P_{x\ nom}$		12	ms

² The Front-End is provided with a minimum hysteresis of 3 V during turn-on and turn-off within the ranges

4.1 INPUT FUSE

Quick-acting 25 A input fuses (6.3 × 32 mm) in series with both the L- and N-line inside the power supply protect against severe defects. The fuses are not accessible from the outside and are therefore not serviceable parts.

4.2 INRUSH CURRENT

The AC-DC power supply exhibits an X capacitance of only 4.3µF, resulting in a low and short peak current, when the supply is connected to the mains. The internal bulk capacitor will be charged through an NTC which will limit the inrush current.

NOTE:

Do not repeat plug-in / out operations below 90sec interval time at maximum input, high temperature condition, or else the internal in-rush current limiting device (NTC) may not sufficiently cool down and excessive inrush current or component failure(s) may result.



4.3 INPUT UNDER-VOLTAGE

If the RMS value of input voltage (either AC or DC) stays below the input undervoltage lockout threshold $V_{i on}$, the supply will be inhibited. Once the input voltage returns within the normal operating range, the supply will return to normal operation again.

4.4 POWER FACTOR CORRECTION

Power factor correction (PFC) (see *Figure 4*) is achieved by controlling the input current waveform synchronously with the input voltage. A fully digital controller is implemented giving outstanding PFC results over a wide input voltage and load ranges. The input current will follow the shape of the input voltage. If for instance the input voltage has a trapezoidal waveform, then the current will also show a trapezoidal waveform. At DC input voltage the PFC is still in operation, but the input current will be DC in this case.

4.5 EFFICIENCY

The high efficiency (see *Figure 2*) is achieved by using state-of-the-art silicon power devices in conjunction with soft-transition topologies minimizing switching losses and a full digital control scheme. Synchronous rectifiers on the output reduce the losses in the high current output path. The rpm of the fan is digitally controlled to keep all components at an optimal operating temperature regardless of the ambient temperature and load conditions.

Figure 3 shows efficiency when input voltage is supplied from a high voltage DC source.

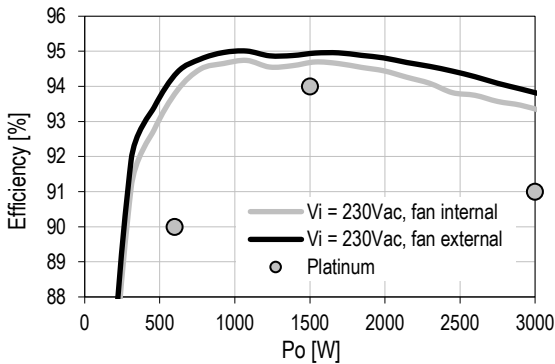

Figure 2 – AC Input Efficiency vs. Load current (ratio metric loading)

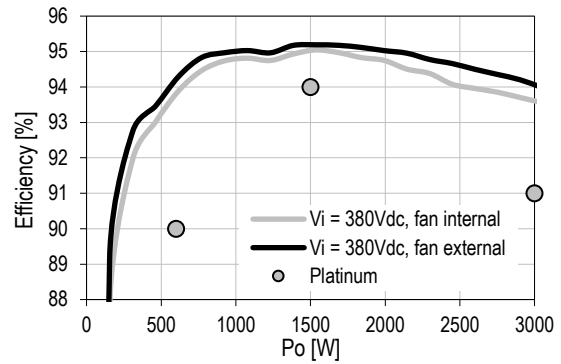

Figure 3 - DC Input Efficiency vs. load current (ratio metric loading)

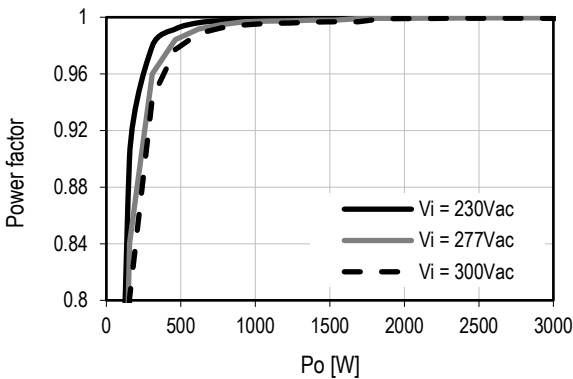

Figure 4 - Power factor vs. Load current

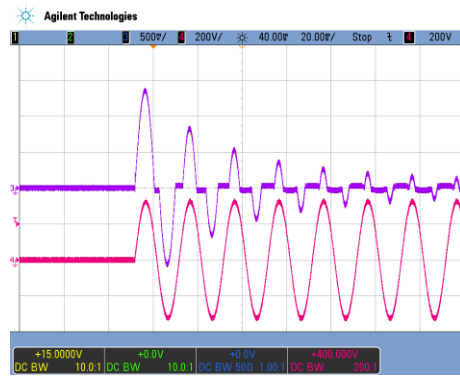

Figure 5 - Inrush current, $V_{in} = 230 \text{ Vac}$, 0° phase angle
CH4: V_{in} (200 V/div), CH3: I_{in} (10 A/div)

5. OUTPUT

General Condition: $T_A = 0...45\text{ °C}$ unless otherwise noted.

PARAMETER	DESCRIPTION / CONDITION	MIN	NOM	MAX	UNIT
Main Output V_1					
$V_1\text{ nom}$	Nominal Output Voltage		12.3		VDC
$V_1\text{ set}$	Output Setpoint Accuracy	-0.5		+0.5	% $V_1\text{ nom}$
$dV_1\text{ tot}$	Total Regulation	$V_1\text{ min to } V_1\text{ max}$, 0 to 100% $I_1\text{ nom}$, $T_a\text{ min to } T_a\text{ max}$		+1	% $V_1\text{ nom}$
$P_1\text{ nom}$	Nominal Output Power	$V_1 = 12.3\text{ VDC}$, $V_{in} < 180\text{ VAC}$	1400		W
$I_1\text{ nom}$	Nominal Output Current	$V_1 = 12.3\text{ VDC}$, $V_{in} < 180\text{ VAC}$	114		ADC
$P_1\text{ nom}$	Nominal Output Power	$V_1 = 12.3\text{ VDC}$, $V_{in} > 180\text{ VAC}$	3000		W
$I_1\text{ nom}$	Nominal Output Current	$V_1 = 12.3\text{ VDC}$, $V_{in} > 180\text{ VAC}$	244		ADC
$I_1\text{ ol}$	Short time over load current	$V_1 = 12.3\text{ VDC}$, $V_{in} > 180\text{ VAC}$ $T_a\text{ min to } T_a\text{ max}$, maximum duration 20 ms (See Section 5.2)		292	A
$V_1\text{ pp}$	Output Ripple Voltage	$V_1\text{ nom}$, $I_1\text{ nom}$, 20 MHz BW (See Section 5.1)		160	mVpp
$dV_1\text{ Load}$	Load Regulation	$I_1 = I_1\text{ nom}$, 0 - 100 % $I_1\text{ nom}$	170		mV
$dV_1\text{ Line}$	Line Regulation	$V_1 = V_1\text{ min... } V_1\text{ max}$	0		mV
$I_1\text{ ol lim}$	Current limitation	$V_1 < 180\text{ VAC}$, $T_a < 45\text{ °C}$	120	127	ADC
		$V_1 < 180\text{ VAC}$, $T_a = 55\text{ °C}$ ³⁾	92	99	
		$V_1 > 180\text{ VAC}$, $T_a < 45\text{ °C}$	248	274	
		$V_1 > 180\text{ VAC}$, $T_a = 55\text{ °C}$ ³⁾	186	212	
dI_{share}	Current Sharing	Deviation from $I_1\text{ tot} / N$, $I_1 > 25\% I_1\text{ nom}$	-5%	+5%	A
dV_{dyn}	Dynamic Load Regulation	$\Delta I_1 = 50\% I_1\text{ nom}$, $I_1 = 5 \dots 100\% I_1\text{ nom}$, $dI_1/dt = 1A/\mu s$, $f_{\Delta I_1} = 0.05\dots 10\text{ kHz}$, Duty $\Delta I_1 = 10\dots 90\%$, recovery within 1% of V_1 final steady state	-0.6	+0.6	V
T_{rec}	Recovery Time			0.5	ms
$t_{AC\ V_1}$	Start-up Time from AC	$V_1 = 10.8\text{ VDC}$ (see Figure 7)		3	sec
$t_{V_1\text{ rise}}$	Rise Time	$V_1 = 10\dots 90\% V_1\text{ nom}$ (see Figure 8)	2.5		ms
C_{Load}	Capacitive Loading	$T_a = 25\text{ °C}$		30000	μF

³⁾ See Figure 20 for linear derating > 45°C

Standby Output V_{SB}					
$V_{SB}\text{ nom}$	Nominal Output Voltage	$I_{SB}\text{ nom}$, $T_{\text{amb}} = 25\text{ °C}$		12	VDC
$V_{SB}\text{ set}$	Output Setpoint Accuracy		-0.5	+0.5	% $V_{SB}\text{ nom}$
$dV_{SB}\text{ tot}$	Total Regulation	$V_1\text{ min to } V_1\text{ max}$, $I_{SB}\text{ nom}$, $T_a\text{ min to } T_a\text{ max}$	-1	+1	% $V_{SB}\text{ nom}$
$P_{SB}\text{ nom}$	Nominal Output Power	$V_{SB} = 12\text{ VDC}$	60		W
$I_{SB}\text{ nom}$	Nominal Output Current	$V_{SB} = 12\text{ VDC}$	5		ADC
$V_{SB}\text{ pp}$	Output Ripple Voltage	$V_{SB}\text{ nom}$, $I_{SB}\text{ nom}$, 20 MHz BW (See Section 5.1)		300	mVpp
dV_{SB}	Droop	0 - 100 % $I_{SB}\text{ nom}$		400	mV
$I_{SB}\text{ lim}$	Current Limitation		6	9	ADC
$dV_{SB}\text{ dyn}$	Dynamic Load Regulation	$\Delta I_{SB} = 50\% I_{SB}\text{ nom}$, $I_{SB} = 5 \dots 100\% I_{SB}\text{ nom}$, $dI_{SB}/dt = 1A/\mu s$, $f_{\Delta I_{SB}} = 0.05\dots 10\text{ kHz}$, Duty $\Delta I_{SB} = 10\dots 90\%$, recovery within 1% of V_{SB} final steady state	-0.6	+0.6	$V_{SB}\text{ nom}$
T_{rec}	Recovery Time			0.5	ms
$t_{AC\ V_{SB}}$	Start-up Time from AC	$V_{SB} = 90\% V_{SB}\text{ nom}$ (see Figure 7)		3	sec
$t_{V_{SB}\text{ rise}}$	Rise Time	$V_{SB} = 10\dots 90\% V_{SB}\text{ nom}$ (see Figure 9)	10		ms
C_{Load}	Capacitive Loading	$T_{\text{amb}} = 25\text{ °C}$		3000	μF



5.1 OUTPUT VOLTAGE RIPPLE

The internal output capacitance at the power supply output (behind OR-ing element) is minimized to prevent disturbances during hot plug. In order to provide low output ripple voltage in the application, external capacitors should be added close to the power supply output.

The setup of *Figure 6* has been used to evaluate suitable capacitor types. The capacitor combinations of Table 1 and Table 2 should be used to reduce the output ripple voltage.

The ripple voltage is measured with 20 MHz BWL, close to the external capacitors.

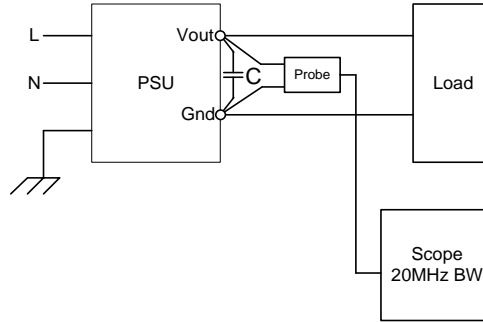

Figure 6 - Output Ripple Test Setup

NOTE: Care must be taken when using ceramic capacitors with a total capacitance of 1 μF to 50 μF on output V1, due to their high quality factor the output ripple voltage may be increased in certain frequency ranges due to resonance effects.

External Capacitor V1	dV1max	Unit
2Pcs 47 μF /16V/X5R/1210	160	mVpp
1Pcs 1000 μF /16V/Low ESR Aluminum/ ϕ 10x20	160	mVpp
1Pcs 270 μF /16V/Conductive Polymer/ ϕ 8x12	160	mVpp
2Pcs 47 μF /16V/X5R/1210 plus 1Pcs 270 μF Conductive Polymer OR 1Pcs 1000 μF Low ESR AlCap	90	mVpp

Table 1 - Suitable Capacitors for V1

External capacitor VSB	dVSBmax	Unit
1Pcs 10 μF /16 V/X7R/1206	300	mVpp

Table 2 - Suitable Capacitors for VSB

The output ripple voltage on VSB is influenced by the main output V1. Evaluating VSB output ripple must be done when maximum load is applied to V1.

5.2 SHORT TIME OVERLOAD

The main output has the capability to allow load current up to 20% above the nominal output current rating for a maximum duration of 20 ms. This allows the system to consume extended power for short time dynamic processes.

5.3 OUTPUT ISOLATION

Main and standby output and all signals are isolated from the chassis and protective earth connection, although the applied voltage must not exceed 100 Vpeak to prevent any damage of the supply.

Internal to the supply the main output ground, standby output ground and signal ground are interconnected through 10 Ω resistors to prevent any circulating current within the supply. In order to prevent any potential difference in outputs or signals within the application these 3 grounds must be directly interconnected at system level. See also section 14 for pins to be interconnected.

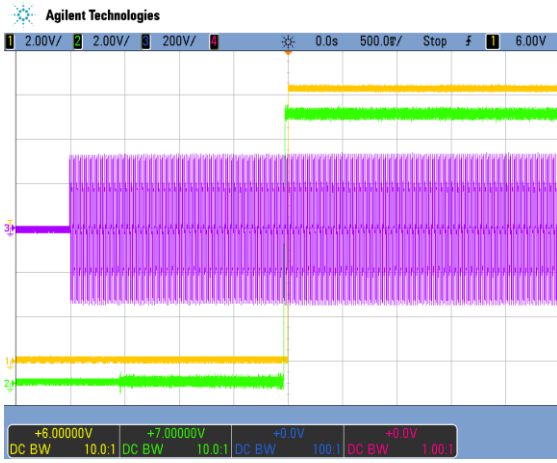

Figure 7 - Turn-On AC Line 230 VAC, full load (500 ms/div)
 CH1: V1 (2 V/div); CH2: VSB (2 V/div); CH3: Vin (200 V/div)

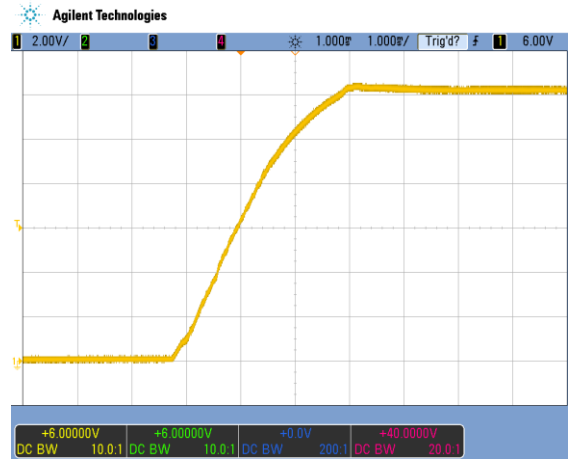

Figure 8 - Turn-On AC Line 230 VAC, full load (1 ms/div)
 CH1: V1 (2 V/div)

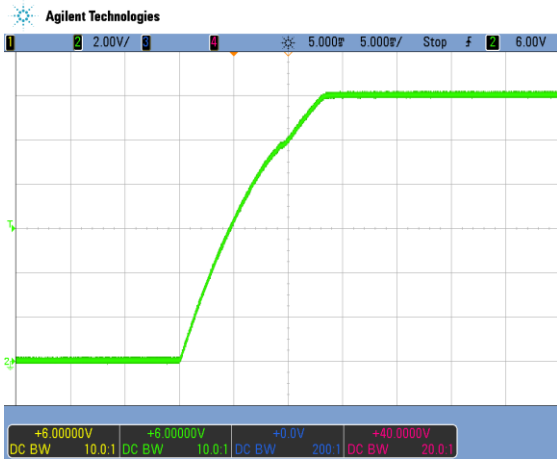

Figure 9 - Turn-On AC Line 230 VAC, full load (5 ms/div)
 CH2: VSB (2 V/div)

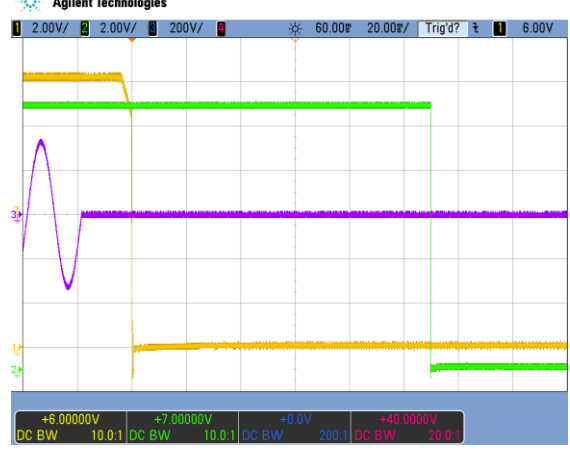

Figure 10 - Turn-Off AC Line 230 VAC, full load (20 ms/div)
 CH1: V1 (2 V/div); CH2: VSB (2 V/div); CH3: Vin (200 V/div)



Figure 11 - Short circuit on V1 (50ms/div)
 CH1: V1 (2V/div) CH2: VSB (2V/div) CH4: I1 (200A/div)

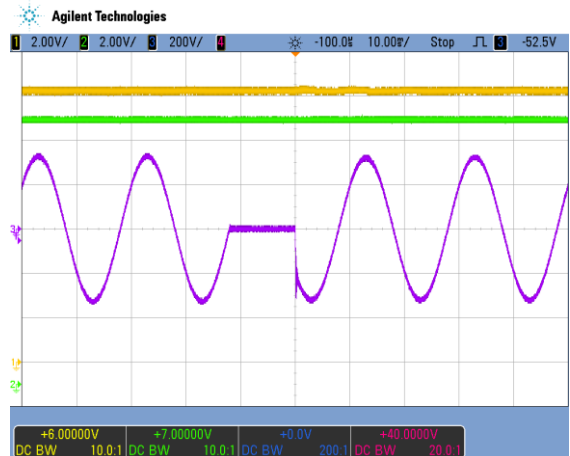

Figure 12 - AC drop out 12ms (10ms/div)
 CH1: V1 (2V/div) CH2: VSB (2V/div) CH3: Vin (200V/div)





Figure 13 - AC drop out 40 ms, full load (20 ms/div)
CH1: V1 (2 V/div); CH2: VSB (2 V/div); CH3: Vin (200 V/div)



Figure 14 - AC drop out 40 ms, full load (200 ms/div), V1 restart after 1 sec
CH1: V1 (5 V/div); CH2: VSB (2 V/div); CH3: I1 (200 V/div)

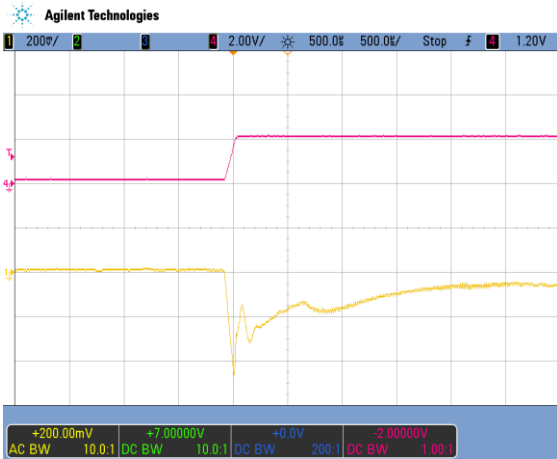

Figure 15 - Load transient V1, 3 to 125 A (500 µs/div)
CH1: V1 (200 mV/div); CH4: I1 (100 A/div)

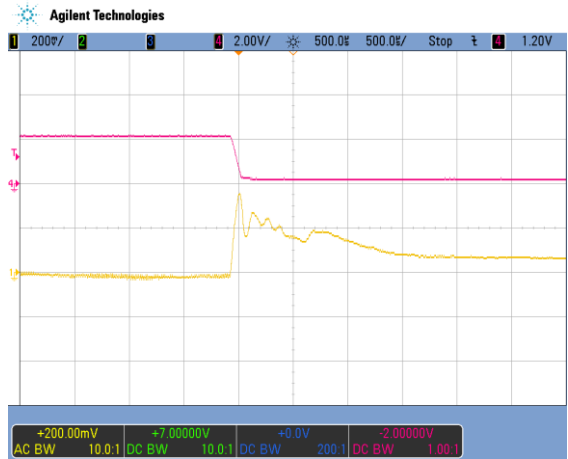

Figure 16 - Load transient V1, 125 to 3 A (500 µs/div)
CH1: V1 (200 mV/div); CH4: I1 (100 A/div)

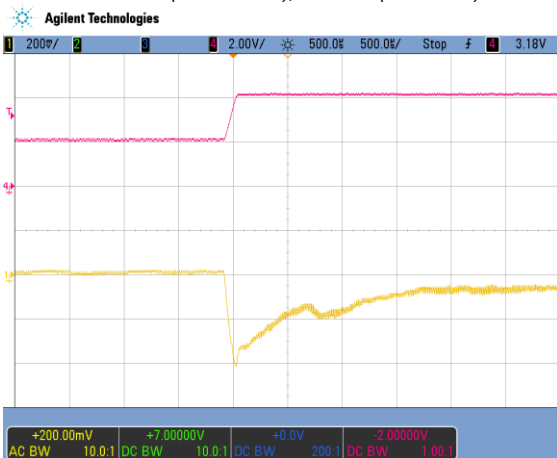

Figure 17 - Load transient V1, 122 to 244 A (500 µs/div)
CH1: V1 (200 mV/div); CH4: I1 (100 A/div)



Figure 18 - Load transient V1, 244 to 122 A (500 µs/div)
CH1: V1 (200 mV/div); CH4: I1 (100 A/div)

6. PROTECTION

PARAMETER	DESCRIPTION / CONDITION	MIN	NOM	MAX	UNIT
F	Input Fuses (L+N)	Not user accessible, quick-acting (F)			A
$V_{I\text{ OV}}$	OV Threshold V_I	13.6	14.2	14.8	VDC
$t_{\text{OV } V_I}$	OV Latch Off Time V_I			1	ms
$V_{\text{SB OV}}$	OV Threshold V_{SB}	13.3	13.9	14.5	VDC
$t_{\text{OV } V_{\text{SB}}}$	OV Latch Off Time V_{SB}			1	ms
$I_{I\text{ lim}}$	Current limitation	$V_I < 180\text{ VAC}, T_a < 45^\circ\text{C}$ $V_I < 180\text{ VAC}, T_a = 55^\circ\text{C}^4$ $V_I > 180\text{ VAC}, T_a < 45^\circ\text{C}$ $V_I > 180\text{ VAC}, T_a = 55^\circ\text{C}^4$	120 92 248 186	127 99 274 212	A
$t_{I\text{ lim}}$	Current limit blanking time	Time to latch off when in over current			ms
$I_{I\text{ ol lim}}$	Current limit during short time overload V_I	Maximum duration 20 ms			A
$I_{I\text{ SC}}$	Max Short Circuit Current V_I	$V_I < 3\text{ V}$			A
$t_{I\text{ SC off}}$	Short circuit latch off time	Time to latch off when in short circuit			ms
$I_{\text{SB lim}}$	Current limitation V_{SB}	6		9	A
$t_{\text{SB lim}}$	Current limit blanking time	Time to hit hiccup when in over current			ms
T_{SD}	Over temperature on critical points	Inlet Ambient Temperature PFC Primary Heatsink Temperature Secondary Sync Mosfet Temperature Secondary OR-ing Mosfet Temperature			60 80 115 125 °C

⁴ See Figure 20 for linear derating > 45°

⁵ Limit set don't include effects of main output capacitive discharge.

6.1 AUTOMATIC RETRY

For all fault conditions except current limitation on Standby output, the supply will shut down for 10sec and restart automatically. The supply will auto-restart from a fault up to 5 times, after that it will latch off. The latch and restart counter can be cleared by recycling the input voltage or the PSON_L input. A failure on the Standby output will shut down both Main and Standby outputs. A failure on the Main output will shut down only the Main output, while Standby continues to operate.

6.2 OVERVOLTAGE PROTECTION

The PFE front-ends provide a fixed threshold overvoltage (OV) protection implemented with a HW comparator. Once an OV condition has been triggered, the supply will shut down and latch the fault condition.

6.3 UNDERVOLTAGE DETECTION

Both main and standby outputs are monitored. LED and PWOK_L pin signal if the output voltage exceeds $\pm 7\%$ of its nominal voltage.

Output undervoltage protection is provided on both outputs. When either V1 or VSB falls below 93% of its nominal voltage, the output is inhibited.



6.4 CURRENT LIMITATION

MAIN OUTPUT

Two different over current protection features are implemented on the main output.

A static over current protection will shut down the output, if the output current does exceed $I_{V1\ lim}$ for more than 20 ms. If the output current is increased slowly this protection will shut down the supply. The main output current limitation level $I_{V1\ lim}$ will decrease if the ambient (inlet) temperature increases beyond 45 °C (see *Figure 20*). Note that the actual current limitation on V1 will kick in at a current level approximately 20 A higher than what is shown in *Figure 20* (see also section 9 for additional information).

The 2nd protection is a substantially rectangular output characteristic controlled by a software feedback loop. This protects the power supply and system during the 20ms blanking time of the static over current protection. If the output current is rising fast and reaches $I_{V1\ ol\ lim}$, the supply will immediately reduce its output voltage to prevent the output current from exceeding $I_{V1\ ol\ lim}$. When the output current is reduced below $I_{V1\ ol\ lim}$, the output voltage will return to its nominal value.

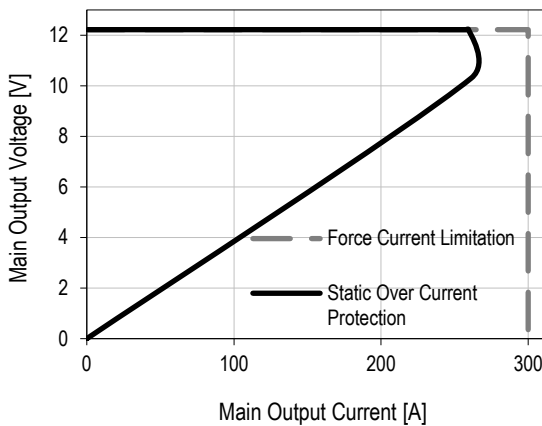

Figure 19 - Current Limitation on V₁ (V_i = 230VAC)

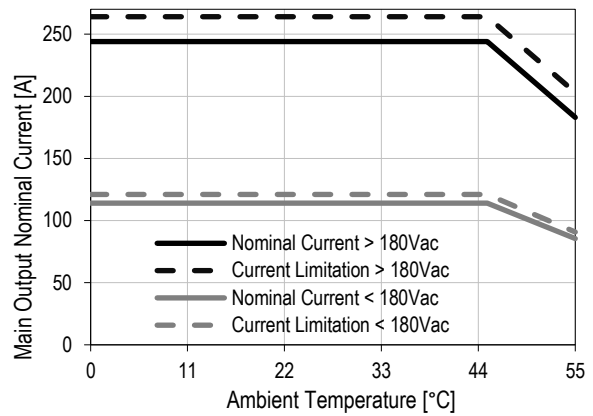

Figure 20 - Derating on V₁ vs. T_a

STANDBY OUTPUT

On the standby output a hiccup type over current protection is implemented. This protection will shut down the standby output immediately when standby current reaches or exceeds $I_{SB\ lim}$. After an off-time of 1s the output automatically tries to restart. If the overload condition is removed the output voltage will reach again its nominal value. At continuous overload condition the output will repeatedly trying to restart with 1s intervals.

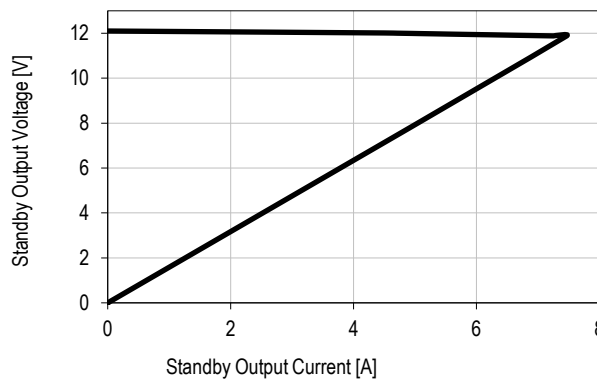

Figure 21 - Current Limitation on V_{SB}

7. MONITORING

PARAMETER		DESCRIPTION / CONDITION	MIN	NOM	MAX	UNIT
$V_{i\ mon}$	Input RMS Voltage	$V_{i\ min} \leq V \leq V_{i\ max}$	-2.5		+2.5	%
$I_{i\ mon}$	Input RMS Current	$I > 4\ A_{rms}$	-5		+5	%
		$I \leq 4\ A_{rms}$	-0.2		+0.2	A_{rms}
$P_{i\ mon}$	True Input Power	$P_i > 700\ W$	-5		+5	%
		$P_i \leq 700\ W$	-35		+35	W
$E_{i\ mon}$	Total Input Energy	$P_i > 700\ W$	-5		+5	%
		$P_i \leq 700\ W$	-35		+35	Wh
$V_{i\ mon}$	V ₁ Voltage		-2		+2	%
$I_{i\ mon}$	V ₁ Current	$I_1 > 30\ A$	-2		+2	%
		$I_1 \leq 30\ A$	-0.6		+0.6	A
$P_{o\ nom}$	Total Output Power	$P_o > 200\ W$	-5		+5	%
		$P_o \leq 200\ W$	-10		+10	W
$E_{o\ mon}$	Total Output Energy	$P_o > 200\ W$	-5		+5	%
		$P_o \leq 200\ W$	-10		+10	Wh
$V_{SB\ mon}$	Standby Voltage		-2		+2	%
$I_{SB\ mon}$	Standby Current	$I_{SB} \leq I_{SB\ nom}$	-0.3		+0.3	A



8. SIGNALING AND CONTROL

8.1 ELECTRICAL CHARACTERISTICS

PARAMETER	DESCRIPTION / CONDITION	MIN	NOM	MAX	UNIT
PSKILL / PSON_L inputs					
V_{IL}	Input low level voltage	-0.2		0.8	V
V_{IH}	Input high level voltage	2.0		3.6	V
$I_{L, H}$	Maximum input sink or source current	0		1	mA
$R_{puPSKILL}$	Internal pull up resistor on PSKILL		10		k Ω
R_{puPSON_L}	Internal pull up resistor on PSON_L		10		k Ω
PWOK_L output					
V_{OL}	Output low level voltage	$I_{sink} < 4 \text{ mA}$	-0.2	0.4	V
V_{puPWOK_L}	External pull up voltage			12	V
R_{puPWOK_L}	Recommended external pull up resistor on PWOK_L at $V_{puPWOK_L} = 3.3 \text{ V}$		10		k Ω
<i>Low level output</i>	All outputs are turned on and within regulation				
<i>High level output</i>	In standby mode or V_1/V_{SB} have triggered a fault condition				
INOK_L output					
V_{OL}	Output low level voltage	$I_{sink} < 4 \text{ mA}$	-0.2	0.4	V
V_{puINOK_L}	External pull up voltage			12	V
R_{puINOK_L}	Recommended external pull up resistor on INOK_L at $V_{puINOK_L} = 3.3 \text{ V}$		10		k Ω
<i>Low level output</i>	Input voltage is within range for PSU to operate				
<i>High level output</i>	Input voltage is not within range for PSU to operate				
SMB_ALERT_L output					
V_{OL}	Output low level voltage	$I_{sink} < 4 \text{ mA}$	-0.2	0.4	V
$V_{puSMB_ALERT_L}$	External pull up voltage			12	V
$R_{puSMB_ALERT_L}$	Recommended external pull up resistor on SMB_ALERT_L at $V_{puSMB_ALERT_L} = 3.3 \text{ V}$		10		k Ω
<i>Low level output</i>	PSU in warning or failure condition				
<i>High level output</i>	PSU is ok				

8.2 INTERFACING WITH SIGNALS

A 15V zener diode is added on all signal pins versus signal ground SGND to protect internal circuits from negative and high positive voltage. Signal pins of several supplies running in parallel can be interconnected directly. A supply having no input power will not affect the signals of the paralleled supplies.

ISHARE pins must be interconnected without any additional components. This in-/output also has a 15 V zener diode as a protection device and is disconnected from internal circuits when the power supply is switched off.

8.3 FRONT LEDs

The front-end has 2 front LEDs showing the status of the supply. LED number one is green and indicates AC power is on or off, while LED number two is bi-colored: green and yellow, and indicates DC power presence or fault situations. For the position of the LEDs see *Table 3* listing the different LED status.



OPERATING CONDITION	LED SIGNALING
AC LED	
AC Line within range	Solid Green
AC Line UV condition	Off
DC LED*	
Normal Operation	Solid Green
PSON_L High	Blinking Yellow (1:1)
V_I or V_{SB} out of regulation	
Over temperature shutdown	
Output over voltage shutdown (V_I or V_{SB})	Solid Yellow
Output under voltage shutdown (V_I or V_{SB})	
Output over current shutdown (V_I or V_{SB})	
Over temperature warning	Blinking Yellow/Green (2:1)
Minor fan regulation error (>5%, <15%)	Blinking Yellow/Green (1:1)

* The order of the criteria in the table corresponds to the testing precedence in the controller.

Table 3 - LED Status

8.4 PRESENT_L

The PRESENT_L is normally a trailing pin within the connector and will contact only once all other connector contacts are closed. This active-low pin is used to indicate to a power distribution unit controller that a supply is plugged in. The maximum sink current on PRESENT_L pin should not exceed 10 mA.

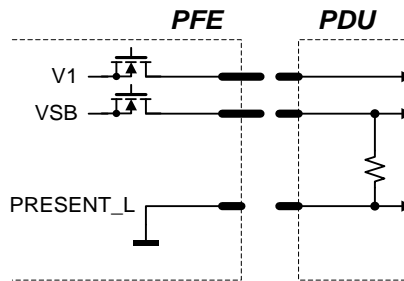

Figure 22 - PRESENT_L signal pin

8.5 PSKILL INPUT

The PSKILL input is an active-low and normally a trailing pin in the connector and is used to disconnect the main output as soon as the power supply is being plugged out. This pin should be connected to SGND in the power distribution unit. The standby output will remain on regardless of the PSKILL input state.

8.6 AC TURN-ON / DROP-OUTS / INOK_L

The power supply will automatically turn-on when connected to the AC line under the condition that the PSON_L signal is pulled low and the AC line is within range. The INOK_L is an open collector output that requires an external pull-up to a maximum of 12 V indicating whether the input is within the range the power supply can use and turn on. The INOK_L signal is active-low. The timing diagram is shown in Figure 23 and referenced in Table 4.



OPERATING CONDITION		MIN	MAX	UNIT
$t_{AC\ VSB}$	AC Line to 90% V_{SB}		3	sec
$t_{AC\ V1}$	AC Line to 90% V_1		3	sec
$t_{INOK_L\ on1}$	INOK_L signal on delay (start-up)		1800	ms
$t_{INOK_L\ on2}$	INOK_L signal on delay (dips)	0	100	ms
$t_{V1\ holdup}$	Effective V_1 holdup time	12	300	ms
$t_{VSB\ holdup}$	Effective V_{SB} holdup time	40	300	ms
$t_{INOK_L\ V1}$	INOK_L to V_1 holdup	7		ms
$t_{INOK_L\ VSB}$	INOK_L to V_{SB} holdup	27		ms
$t_{V1\ off}$	Minimum V_1 off time	1000	1200	ms
$t_{VSB\ off}$	Minimum V_{SB} off time	1000	1200	ms
$t_{V1\ dropout}$	Minimum V_1 dropout time	12		ms
$t_{VSB\ dropout}$	Minimum V_{SB} dropout time	40		ms

Table 4 - AC Turn-on / Dip Timing

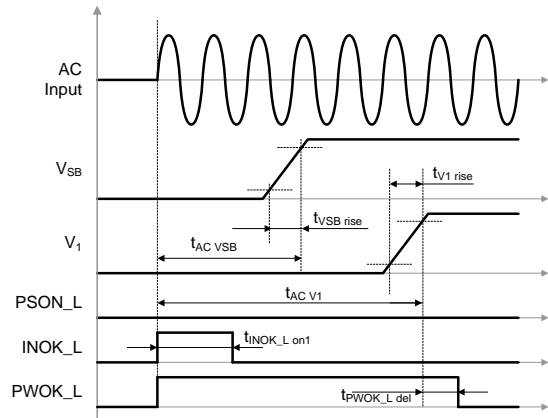

Figure 23 - AC turn-on timing



Figure 24 - AC short dips

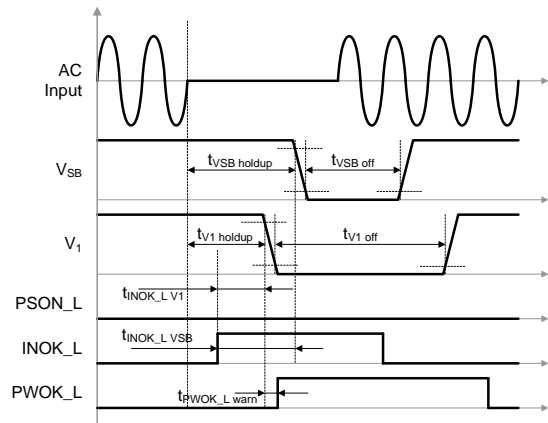

Figure 25 - AC long dips

8.7 PSON_L INPUT

The PSON_L is an internally pulled-up (3.3 V) input signal to enable / disable the main output V1 of the front-end. This active-low pin is also used to clear any latched fault condition. The timing diagram is given in Figure 26 and the parameters in Table 5.

OPERATING CONDITION		MIN	MAX	UNIT
$t_{PSON_L\ V1on}$	PSON_L to V_1 delay (on)	190	220	ms
$t_{PSON_L\ V1off}$	PSON_L to V_1 delay (off)	0	100	ms

Table 5 - PSON_L timing

8.8 PWOK_L SIGNAL

The PWOK_L is an open collector output that requires an external pull-up to a maximum of 12 V indicating whether both VSB and V1 outputs are within regulation. This pin is active-low. The timing diagram is shown in Figure 26 and referenced in Table 6.



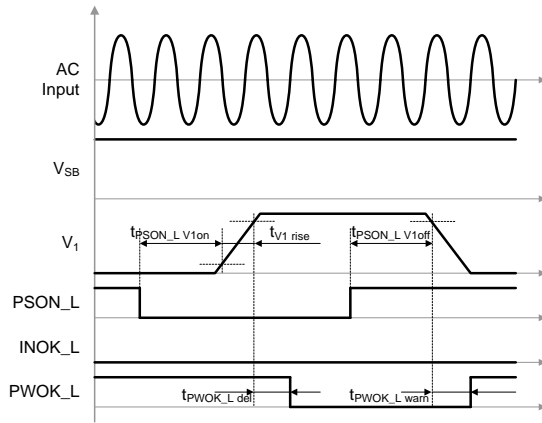

Figure 26 - PSON_L turn-on/off timing

OPERATING CONDITION		MIN	MAX	UNIT
tPWOK_L del	V _I to PWOK_L delay (on)	250	350	ms
tPWOK_L warn	V _I to PWOK_L delay (off)	0	5	ms

Table 6 - PWOK_L timing

8.9 CURRENT SHARE

The PFE front-ends have an active current share scheme implemented for V1. All the ISHARE current share pins need to be interconnected in order to activate the sharing function. If a supply has an internal fault or is not turned on, it will disconnect its ISHARE pin from the share bus. This will prevent dragging the output down (or up) in such cases.

The current share function uses an analog bus. The controller implements a Master/Slave current share function. The power supply providing the largest current among the group is automatically the Master. The other supplies will operate as Slaves and increase their output current to a value close to the Master by slightly increasing their output voltage. The voltage increase is limited to +250 mV.

The standby output uses a passive current share method (droop output voltage characteristic).

No of paralleled PSUs	Maximum available power on main 12 V without redundancy	Maximum available power on main 12 V with n+1 redundancy	Maximum available power on standby output
1	3000 W	-	60 W
2	5850 W	3000 W	60 W
3	8700 W	5850 W	60 W
4	11550 W	8700 W	60 W
5	14400 W	11550 W	60 W
6	17250 W	14400 W	60 W

Table 7 - Power available when PSU in redundant operation

8.10 SENSE INPUTS

Main output has sense lines implemented to compensate for voltage drop on load wires. The maximum allowed voltage drop is 200 mV on the positive rail and 100 mV on the PGND rail.

With open sense inputs the main output voltage will rise by 250 mV. Therefore, if not used, these inputs should be connected to the power output and PGND close to the power supply connector. The sense inputs are protected against short circuit. In this case the power supply will shut down.

8.11 I2C / POWER MANAGEMENT BUS COMMUNICATION

The interface driver in the PFE supply is referenced to the SGND. The PFE supply is a communication slave device only; it never initiates messages on the I²C bus by itself. The communication bus voltage and timing is defined in Table 8 and further characterized through:



- There are 100 kΩ internal pull-up resistors
- The SDA/SCL IOs must be pull-up externally to 3.3 ± 0.3 V
- Pull-up resistor should be 2 – 5 kΩ to ensure SMBUS compliant signal rise times
- I²C clock speed up to 100 kbps
- Clock stretching limited to 1 ms
- SCL low time-out of >25 ms with recovery within 10 ms
- Recognizes any time Start/Stop bus conditions

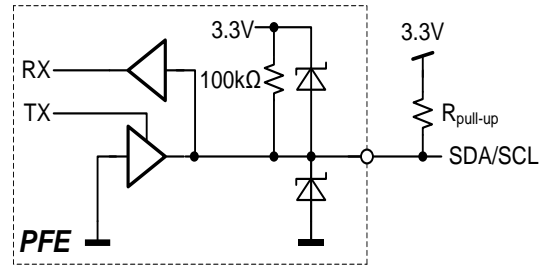

Figure 27 - Physical layer of communication interface

The SMB_ALERT_L signal indicates that the power supply is experiencing a problem that the system agent should investigate. This is a logical OR of the Shutdown and Warning events. Communication to the DSP or the EEPROM will be possible as long as the input AC (DC) voltage is provided. If no AC (DC) is present, communication to the unit is possible as long as it is connected to a live VSB output (provided e.g. by the redundant unit). If only V1 is provided, communication is not possible.

PARAMETER	DESCRIPTION	CONDITION	MIN	MAX	UNIT
V _L	Input low voltage		-0.2	0.4	V
V _{IH}	Input high voltage		2.1	3.6	V
V _{hys}	Input hysteresis		0.15		V
V _{OL}	Output low voltage	4 mA sink current	0	0.4	V
t _r	Rise time for SDA and SCL		20+0.1C _b *	300	ns
t _{of}	Output fall time V _{IHmin} → V _{ILmax}	10 pF < C _b * < 400 pF	20+0.1C _b *	250	ns
I	Input current SCL/SDA	0.1 VDD < V _i < 0.9 VDD	-10	10	μA
C _i	Capacitance for each SCL/SDA			10	pF
f _{SCL}	SCL clock frequency		0	100	kHz
R _{pu}	External pull-up resistor	f _{SCL} ≤ 100 kHz		1000 ns / C _b *	Ω
t _{HDSTA}	Hold time (repeated) START	f _{SCL} ≤ 100 kHz	4.0		μs
t _{LOW}	Low period of the SCL clock	f _{SCL} ≤ 100 kHz	4.7		μs
t _{HIGH}	High period of the SCL clock	f _{SCL} ≤ 100 kHz	4.0		μs
t _{SUSTA}	Setup time for a repeated START	f _{SCL} ≤ 100 kHz	4.7		μs
t _{HDDAT}	Data hold time	f _{SCL} ≤ 100 kHz	0	3.45	μs
t _{SUDAT}	Data setup time	f _{SCL} ≤ 100 kHz	250		ns
t _{SUSTO}	Setup time for STOP condition	f _{SCL} ≤ 100 kHz	4.0		μs
t _{BUF}	Bus free time between STOP and START	f _{SCL} ≤ 100 kHz	4.7		μs
EEPROM_WP					
V _L	Input low voltage		-0.2	0.4	V
V _{IH}	Input high voltage		2.1	3.6	V
I	Input sink or source current		-1	1	mA
R _{pu}	Internal pull-up resistor to 3.3V			10k	Ω

* C_b = Capacitance of bus line in pF, typically in the range of 10...400 pF

Table 8 - I²C / SMBus Specification

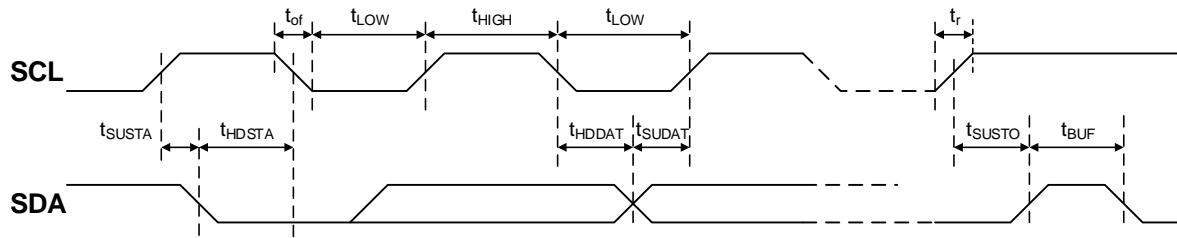

Figure 28 - I²C / SMBus Timing

8.12 ADDRESS

The supply supports Power Management Bus communication protocol. Its address is fixed to 0x20. The EEPROM is at fixed address = 0xA0.

8.13 CONTROLLER AND EEPROM ACCESS

The controller and the EEPROM in the power supply share the same I²C bus physical layer (see Figure 29). In order to write to the EEPROM, the write protection needs to be disabled by setting EEPROM_WP input correctly. If EEPROM_WP is High, write is not allowed to the EEPROM and if Low, write is allowed. The EEPROM provides 2k bytes of user memory. None of the bytes are used for the operation of the power supply.

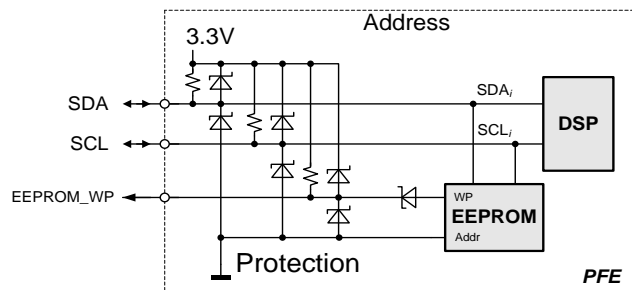

Figure 29 - I²C Bus to DSP and EEPROM

8.14 EEPROM PROTOCOL

The EEPROM follows the industry communication protocols used for this type of device. Even though page write / read commands are defined, it is recommended to use the single byte write / read commands.

WRITE

The write command follows the SMBus 1.1 Write Byte protocol. After the device address with the write bit cleared a first byte with the data address to write to is sent followed by the data byte and the STOP condition. A new START condition on the bus should only occur after 5ms of the last STOP condition to allow the EEPROM to write the data into its memory.



READ

The read command follows the SMBus 1.1 Read Byte protocol. After the device address with the write bit cleared the data address byte is sent followed by a repeated start, the device address and the read bit set. The EEPROM will respond with the data byte at the specified location.



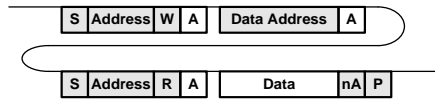

8.15 POWER MANAGEMENT BUS PROTOCOL

The Power Management Bus is an open standard protocol that defines means of communicating with power conversion and other devices. For more information, please see the System Management Interface Forum web site at: www.powerSIG.org.

Power Management Bus command codes are not register addresses. They describe a specific command to be executed. PFE3000-12-069RA supply supports the following basic command structures:

- Clock stretching limited to 1 ms
- SCL low time-out of >25 ms with recovery within 10 ms
- Recognized any time Start/Stop bus conditions

WRITE

The write protocol is the SMBus 1.1 Write Byte/Word protocol. Note that the write protocol may end after the command byte or after the first data byte (Byte command) or then after sending 2 data bytes (Word command).

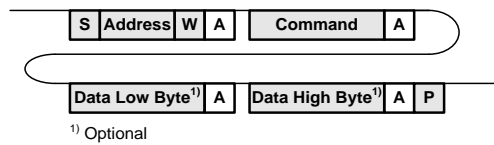

In addition, Block write commands are supported with a total maximum length of 255 bytes. See PFE3000-12-069RA Power Management Bus Communication Manual BCA.00070 for further information.

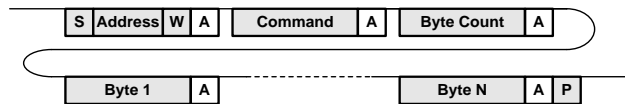

READ

The read protocol is the SMBus 1.1 Read Byte/Word protocol. Note that the read protocol may request a single byte or word.

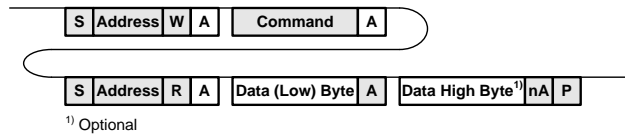

In addition, Block read commands are supported with a total maximum length of 255 bytes. See PFE3000-12-069RA Power Management Bus Communication Manual BCA.00070 for further information.

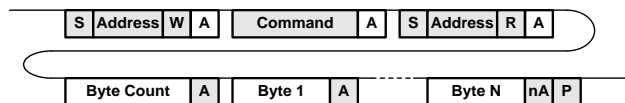

8.16 GRAPHICAL USER INTERFACE

Bel Power Solutions I²C Utility provides a Windows® Vista/Win7/8 compatible graphical user interface allowing the programming and monitoring of the PFE3000-12-069RA Front-End. The utility can be downloaded on belfuse.com/power-solutions and supports the Power Management Bus protocol.

The GUI allows automatic discovery of the units connected to the communication bus and will show them in the navigation tree. In the monitoring view the power supply can be controlled and monitored.

If the GUI is used in conjunction with the PFE3000-12-069RA Evaluation Kit it is also possible to control the PSON_L pin(s) of the power supply.

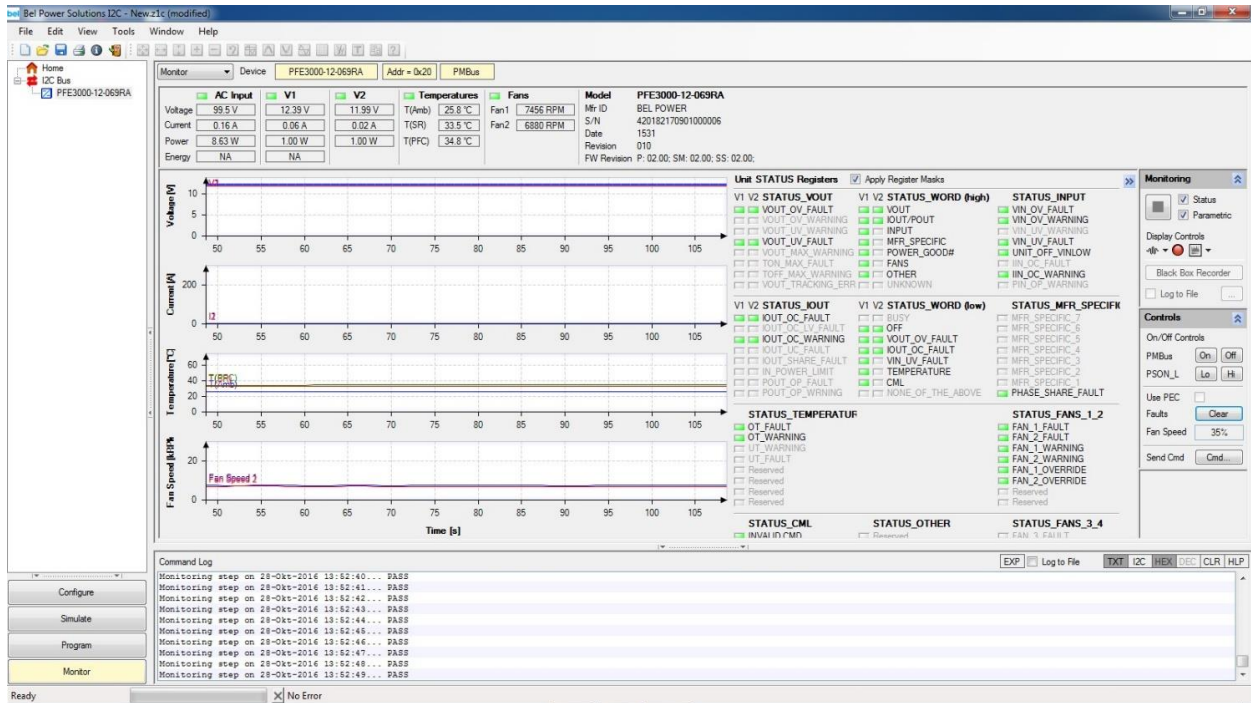

Figure 30 - Monitoring dialog of the I2C Utility

9. TEMPERATURE AND FAN CONTROL

To achieve best cooling results sufficient airflow through the supply must be ensured. Do not block or obstruct the airflow at the rear of the supply by placing large objects directly at the output connector. The PFE3000-12-069RA is provided with a reverse airflow, which means the air enters through the front of the supply and leaves at the rear. PFE supplies have been designed for horizontal operation.

The fan inside of the supply is controlled by a microprocessor. The rpm of the fan is adjusted to ensure optimal supply cooling and is a function of output power and the inlet temperature.



Figure 31 - Airflow Direction



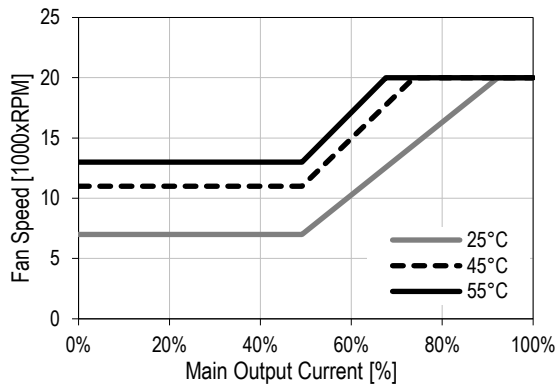

Figure 32 - Fan speed vs. main output load for PFE3000-12-069RA

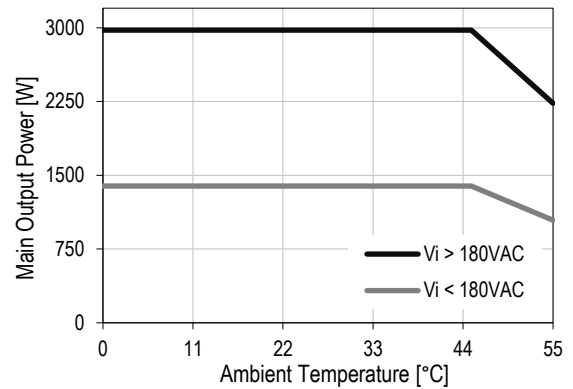

Figure 33 - Thermal derating for PFE3000-12-069RA

10. ELECTROMAGNETIC COMPATIBILITY

10.1 IMMUNITY

NOTE: Most of the immunity requirements are derived from EN 55024:1998/A2:2003.

PARAMETER	DESCRIPTION / CONDITION	CRITERION
ESD Contact Discharge	IEC / EN 61000-4-2, ±8 kV, 25+25 discharges per test point (metallic case, LEDs, connector body)	A
ESD Air Discharge	IEC / EN 61000-4-2, ±15 kV, 25+25 discharges per test point (non-metallic user accessible surfaces)	A
Radiated Electromagnetic Field	IEC / EN 61000-4-3, 10 V/m, 1 kHz/80% Amplitude Modulation, 1 μs Pulse Modulation, 10 kHz...2 GHz	A
Burst	IEC / EN 61000-4-4, level 3 AC port ±2 kV, 1 minute DC port ±1 kV, 1 minute	A
Surge	IEC / EN 61000-4-5 Line to earth: level 3, ±2 kV Line to line: level 2, ±1 kV	A
RF Conducted Immunity	IEC/EN 61000-4-6, Level 3, 10 Vrms, CW, 0.1 ... 80 MHz	A
Voltage Dips and Interruptions	IEC/EN 61000-4-11 1: Vi 230Volts, 100% Load, Dip 100%, Duration 12ms 2: Vi 230Volts, 100% Load, Dip 100%, Duration < 150 ms 3: Vi 230Volts, 100% Load, Dip 100%, Duration > 150 ms	A V1: B, VSB: A B

10.2 EMISSION

PARAMETER	DESCRIPTION / CONDITION	CRITERION
Conducted Emission	EN55022 / CISPR 22: 0.15 ... 30 MHz, QP and AVG	Class A
Radiated Emission	EN55022 / CISPR 22: 30 MHz ... 1 GHz, QP	Class A
Harmonic Emissions	IEC61000-3-2, Vin = 115/230 VAC, 50 Hz, 100% Load	Class A
Acoustical Noise	Sound power statistical declaration (ISO 9296, ISO 7779, IS9295) @ 50% load	60 dBA
AC Flicker	IEC / EN 61000-3-3, d _{max} < 3.3%	PASS

11. SAFETY / APPROVALS

Maximum electric strength testing is performed in the factory according to IEC/EN 62368-1, and UL/CSA 62368-1. Input-to-output electric strength tests should not be repeated in the field. Bel Power Solutions will not honor any warranty claims resulting from electric strength field tests.

PARAMETER	DESCRIPTION / CONDITION	MIN	NOM	MAX	UNIT
Agency Approvals	Approved to the latest edition of the following standards: <ul style="list-style-type: none"> • IEC62368-1 (CB) • EN62368-1 (Nemko) • UL/CSA62368-1 (cCSAus) • CNS15598-1, CNS15936 (BSMI) • EAC, (Russia) • BIS, (India) • KCC Safety/EMC, (South Korea) 				
Isolation Strength	Input (L/N) to case (PE) Input (L/N) to output Output to case (PE)				Basic Reinforced Functional
d_c Creepage / Clearance	Primary (L/N) to protective earth (PE) Primary to secondary				
Electrical Strength Test	Input to case Input to output (tested by manufacturer only)	2500 5000			VDC

12. ENVIRONMENTAL

PARAMETER	DESCRIPTION / CONDITION	MIN	NOM	MAX	UNIT
T_A Ambient Temperature	$V_{i\ min}$ to $V_{i\ max}$, I_{nom} , $I_{SB\ nom}$ at 4000 m $V_{i\ min}$ to $V_{i\ max}$, I_{nom} , $I_{SB\ nom}$ at 1800 m	0		+35	°C
T_{Aext} Extended Temp. Range	Derated output (see <i>Figure 20</i> and <i>Figure 33</i>) at 1800 m	+45		+55	°C
T_S Storage Temperature	Non-operational	-40		+70	°C
Altitude	Operational, above Sea Level (see derating)	-		4000	m
M_A Audible Noise	$V_{i\ nom}$, 50% I_{nom} , $T_A = 25^\circ\text{C}$		60		dBA
Cooling	System Back Pressure			0.5	in-H ₂ O

13. MECHANICAL

PARAMETER	DESCRIPTION / CONDITION	MIN	NOM	MAX	UNIT
Dimensions	Width		69		mm
	Height		42		mm
	Depth		555		mm
m Weight			2.60		kg

NOTE: A 3D step file of the power supply casing is available on request.



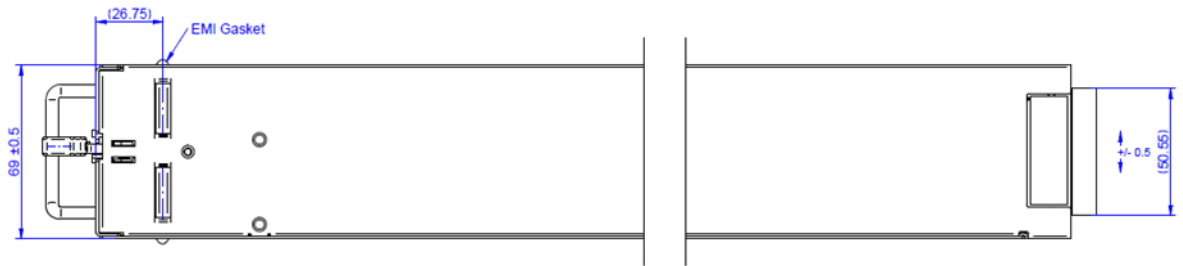

Figure 34 - Bottom view

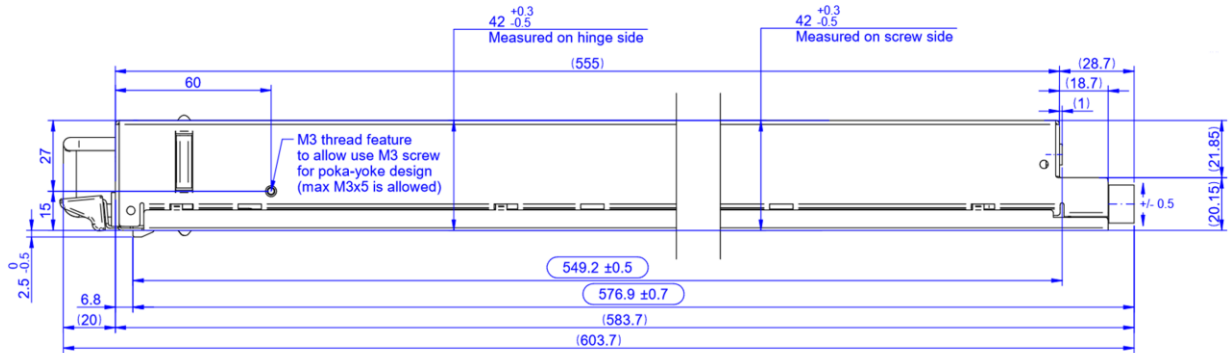

Figure 35 - Side view

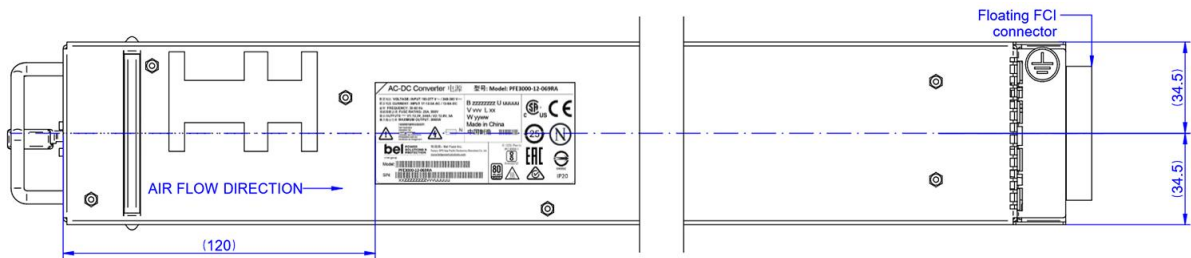

Figure 36 - Top view

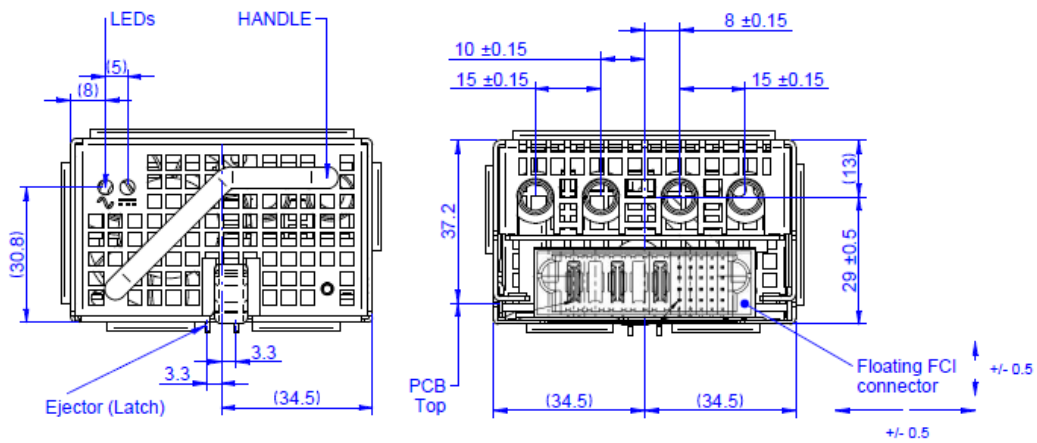

Figure 37 - Front and Rear view

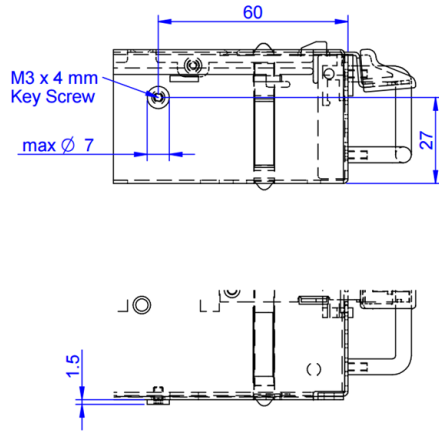

Figure 38 - PFE3000-12-069RA with Key-in screw dimension (Option code S366)

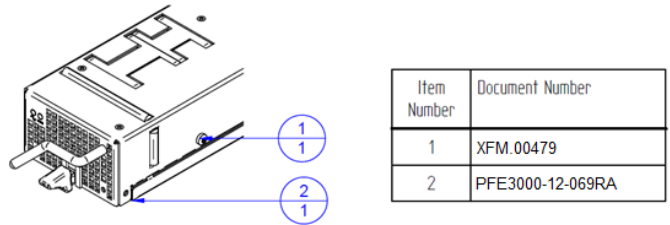
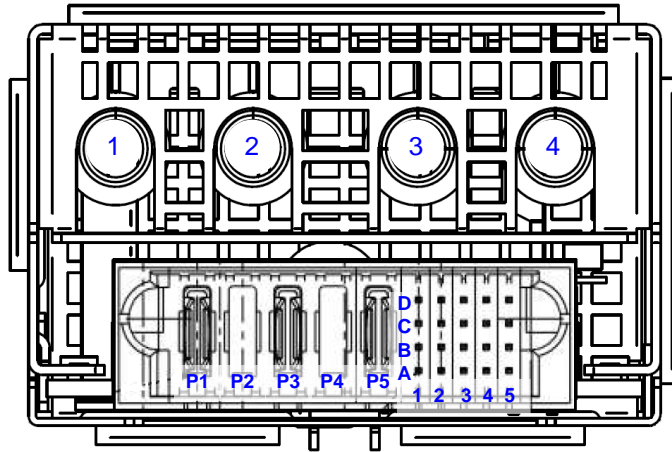

Figure 39 - PFE3000-12-069RA with Key-in screw (Option code S366)

14. CONNECTORS



Unit: FCI Connectors P/N 51939-768LF or equivalent
 Mating connector: FCI Connectors P/N 51915-401LF
 For Main Output Pins, see section 15

Note: A1 and A2 are Trailing Pin (short pins)



PIN	NAME	DESCRIPTION
Output		
3,4	V1	+12 VDC main output
1,2	PGND	+12 VDC main output ground
Input Pins		
P1	LIVE	AC Live Pin
P2	N.C	No metal pin connection
P3	NEUTRAL	AC Neutral Pin
P4	N.C.	No metal pin connection
P5	P.E.	Protective Earth Pin
Control Pins		
A1	PSKILL	Power supply kill (trailing pin): active-high
B1	PWOK_L	Power OK signal output: active-low
C1	INOK_L	Input OK signal: active-low
D1	PSON_L	Power supply on input: active-low
A2	PRESENT_L	Power supply present (trailing pin): active-low
B2	SGND	Signal ground* (return)
C2	SGND	Signal ground* (return)
D2	SGND	Signal ground* (return)
A3	SCL	I ² C clock signal line
B3	SDA	I ² C data signal line
C3	SMB_ALERT_L	SMB Alert signal output: active-low
D3	ISHARE	V ₁ Current share bus
A4	EEPROM_WP	EEPROM write protect
B4	RESERVED	Reserved
C4	V1_SENSE_R	Main output negative sense
D4	V1_SENSE	Main output positive sense
A5	VS _B	Standby positive output
B5	VS _B	Standby positive output
C5	VS _B _GND	Standby Ground*
D5	VS _B _GND	Standby Ground*

* These pins should be connected to PGND on the system. See Section 8 for pull up resistor settings of signal pins. All signal pins are referred to SGND



Table 9 – Pin assignment

15. SHELF LEVEL CONFIGURATION (PROVISIONAL)

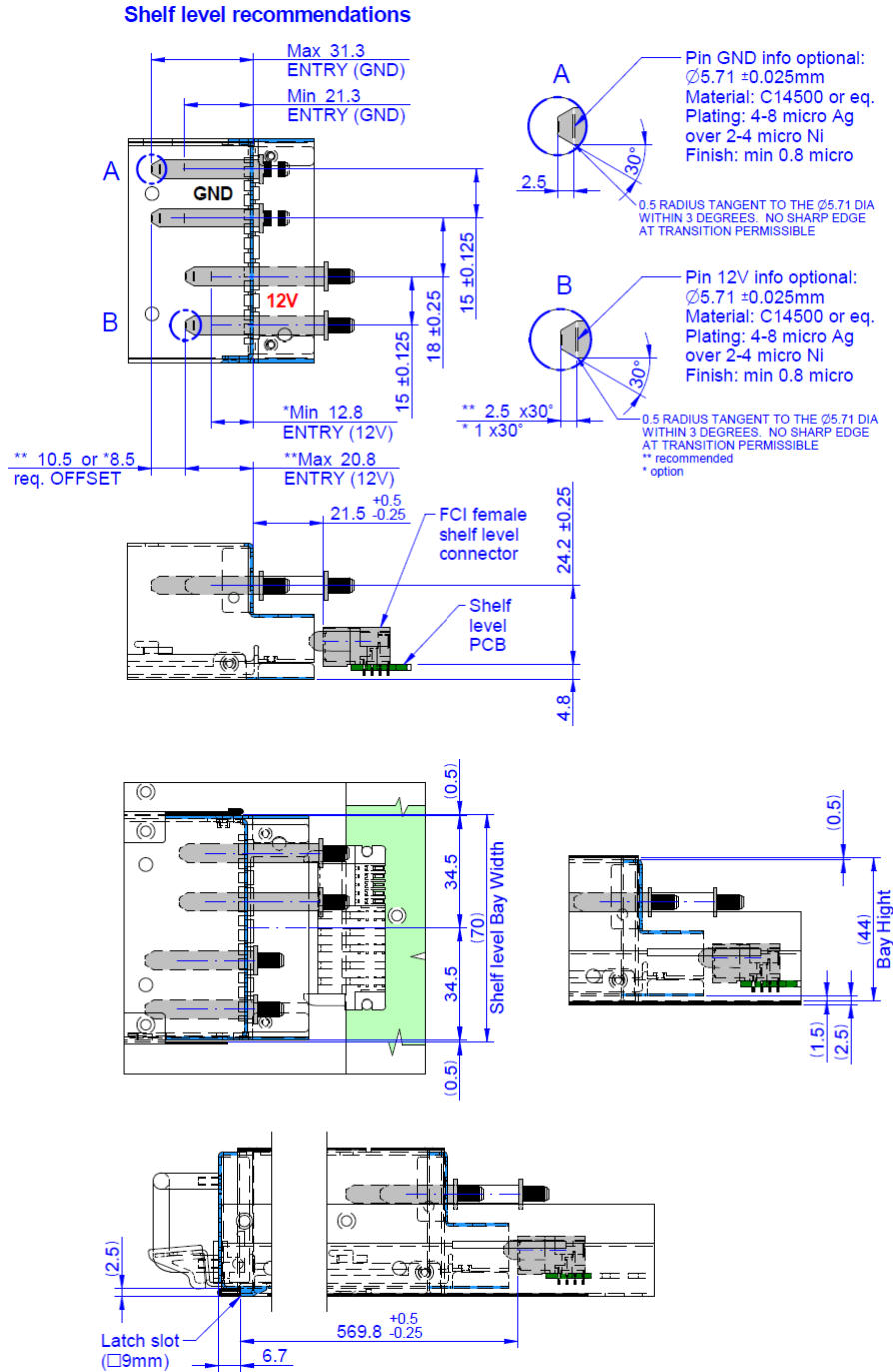
The recommended pin configuration below is based on company's own Shelf design and provided here as reference. Customer pin lengths within the range indicated is acceptable.



16. ACCESSORIES

ITEM	DESCRIPTION	ORDERING PN	SOURCE
	I²C Utility Windows Vista/7/8 compatible GUI to program, control and monitor PFE Front-Ends (and other I²C units)	N/A	belfuse.com/power-solutions
	Single Connector Board Connector board to operate PFE3000-12-069RA unit. Includes an on-board USB to I²C converter (use I²C Utility as desktop software).	YTM.U0M00.0	Bel Power Solutions
	AC Can Filter Recommended AC can filter used on system side.	C20F.0011	Schurter Inc.
		20GENG3E-R	Delta Electronics
	Key-in Screw Screw for PSU Orientation.	XFM.00479	Focus Metal

17. REVISION HISTORY

REV	DESCRIPTION	PSU PRODUCT VERSION	DATE	AUTHOR
AA	Initial Release of Datasheet.	V001 V004 V007	11-27-2013	GS
AB	<ul style="list-style-type: none"> Handle position and size has changed to a diagonal format to allow better handling/grip. +12VSB turn-on delay is changed from 2 seconds to 3 seconds. Main output will only turn on (if enabled by PSKILL and PSON) once +12VSB is in regulation. Datasheet format was changed to Bel Power Solution. 	V008	10-22-2014	GS
AC	<ul style="list-style-type: none"> Added option code model in ordering information. S101 denotes Screw for Key-in feature is added. 	V009	12-22-2014	GS
AD	<ul style="list-style-type: none"> +12VSB parameter change in output ripple voltage, droop, and current read back accuracy. PSU Fans is supplied only from Internal Auxiliary. Option code is changed from S101 to S366. Added Revision History. 	V010	09-09-2015	GS
AE	<ul style="list-style-type: none"> PSU Revision on product label was incremented due to internal documentation. Clarification on Dynamic Load Regulation, Mechanical Drawing and Key-in Screw accessory for option code S366. 	V011	10-28-2016	GS
AE	<ul style="list-style-type: none"> Passed EAC certification and added EAC logo on product label. 	V204	04-06-2017	GS
AF	<ul style="list-style-type: none"> PSKILL and SMB_ALERT_L pin active state description on section 14 was corrected but no functional change. PSU firmware was updated to support calibration of MFR Model suffix. Passed BIS certification and added BIS logo on product label. Transfer 80plus platinum logo on product label. Mechanical update on section 13 for PSU height tolerance. 	V205	05-09-2017	GS
AF1	<ul style="list-style-type: none"> Mechanical update on section 13. PSU height tolerance on hinge side was adjusted to 42 +0.3/-0.5mm. Removed "80plus optional coloured label" on PSU drawing. 	V205	08-14-2017	GS
	<ul style="list-style-type: none"> PSU firmware was updated to improve I2C during hot plug. Passed KCC certification and added KCC logo on product label. 	V206	11-28-2017	GS
AG	<ul style="list-style-type: none"> PMBus™ changed to Power Management Bus; a disclaimer added to the first page: Disclaimer: PMBus is a registered trademark of SMIF, Inc. Figure 28. I²C / SMBus Timing updated 	V207	01-09-2018	GS
AH	<ul style="list-style-type: none"> Add "or equivalent" the PSU output connector at section 14 Update the safety-approve standard and efficiency sentence at page 1 Update the safety approve standard and electrical strength test at section 11 	V207	08-18-2023	Xiao Xue

For more information on these products consult: tech.support@psbel.com

NUCLEAR AND MEDICAL APPLICATIONS - Products are not designed or intended for use as critical components in life support systems, equipment used in hazardous environments, or nuclear control systems.

TECHNICAL REVISIONS - The appearance of products, including safety agency certifications pictured on labels, may change depending on the date manufactured. Specifications are subject to change without notice.





Asia-Pacific	Europe, Middle East	North America
+86 755 298 85888	+353 61 49 8941	+1 866 513 2839



Looking for pricing, stock, or lifecycle information?

Click below to explore more details on WIN SOURCE:

-  [View YTM.U0M00.0 on WIN SOURCE](#)
-  [Bel Power Solutions Information](#)

Optimize Your Supply Chain with WIN SOURCE Solutions

-  Global Sourcing Solution
-  Obsolete Management
-  Cost Control Management
-  Shortage Management
-  Alternative Solution
-  Excess Inventory Management