



**THE DATASHEET OF  
PCA85262ATT/AJ**





# PCA85262

Automotive 32 x 4 LCD driver for low multiplex rates

Rev. 4 — 30 September 2021

Product data sheet

## 1 General description

---

The PCA85262 is a peripheral device which interfaces to almost any Liquid Crystal Display (LCD)<sup>1</sup> with low multiplex rates. It generates the drive signals for any static or multiplexed LCD containing up to four backplanes and up to 32 segments. It can be easily cascaded for larger LCD applications. The PCA85262 is compatible with most microcontrollers and communicates via the two-line bidirectional I<sup>2</sup>C-bus. Communication overheads are minimized by a display RAM with auto-incremented addressing, by hardware subaddressing, and by display memory switching (static and duplex drive modes).

For a selection of NXP LCD segment drivers, see [Table 23](#)

## 2 Features and benefits

---

- AEC-Q100 grade 2 compliant for automotive applications
- Single chip LCD controller and driver
- Selectable backplane drive configuration: static, 2, 3, or 4 backplane multiplexing
- Selectable display bias configuration: static, 1/2, or 1/3
- Internal LCD bias generation with voltage-follower buffers
- 32 segment drives:
  - Up to 16 7-segment numeric characters
  - Up to 8 14-segment alphanumeric characters
  - Any graphics of up to 128 segments/elements
- 32 × 4-bit RAM for display data storage
- Display memory bank switching in static and duplex drive modes
- Versatile blinking modes
- Independent supplies possible for LCD and logic voltages
- Wide power supply range: from 1.8 V to 5.5 V
- Wide logic LCD supply range:
  - From 2.5 V for low-threshold LCDs
  - Up to 8.0 V for guest-host LCDs and high-threshold twisted nematic LCDs
- Low power consumption
- Extended temperature range up to 105 °C
- 400 kHz I<sup>2</sup>C-bus interface
- No external components required

---

<sup>1</sup> The definition of the abbreviations and acronyms used in this data sheet can be found in [Section 21](#).



### 3 Ordering information

Table 1. Ordering information

Type number	Topside mark	Package		
		Name	Description	Version
PCA85262ATT/A	PCA85262TT	TSSOP48	plastic thin shrink small outline package; 48 leads; body width 6.1 mm	SOT362-1

#### 3.1 Ordering options

Table 2. Ordering options

Type number	Orderable part number	Package	Packing method <sup>[1]</sup>	Minimum order quantity	Temperature
PCA85262ATT/A	PCA85262ATT/AJ <sup>[2]</sup>	TSSOP48	reel, 13 inch, q1, non dry pack	2000	T <sub>amb</sub> = -40 °C to +85 °C
	PCA85262ATT/AY	TSSOP48	reel, 13 inch, q1, dry pack	2000	T <sub>amb</sub> = -40 °C to +85 °C

[1] Standard packing quantities and other packaging data are available at [www.nxp.com/packages/](http://www.nxp.com/packages/)

[2] Discontinuation notice 202107021DN - drop-in replacement is PCA85262ATT/AY - this is documented in PCN202102010F01.



5.1 Pinning

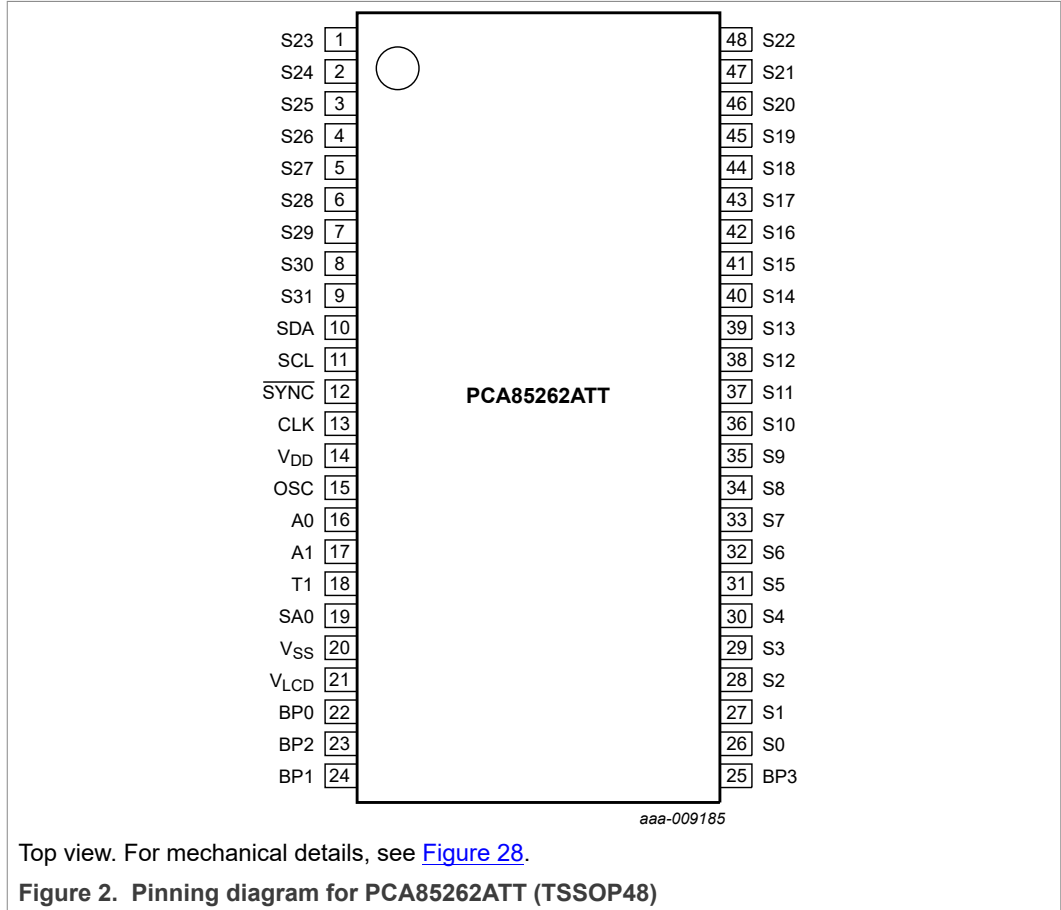

5.2 Pin description

Table 3. Pin description of PCA85262ATT (TSSOP48)

Input or input/output pins must always be at a defined level ( $V_{SS}$  or  $V_{DD}$ ) unless otherwise specified.

Symbol	Pin	Type	Description
SDA	10	input/output	I <sup>2</sup> C-bus serial data line
SCL	11	input	I <sup>2</sup> C-bus serial clock
SYNC	12	input/output	cascade synchronization input or output; if not used it must be left open
CLK	13	input/output	clock line
V <sub>DD</sub>	14	supply	supply voltage
OSC	15	input	internal oscillator enable
A0, A1	16, 17	input	subaddress inputs
T1	18	input	dedicated testing pin; to be tied to V <sub>SS</sub> in application mode
SA0	19	input	I <sup>2</sup> C-bus address input

Table 3. Pin description of PCA85262ATT (TSSOP48)...continued

Input or input/output pins must always be at a defined level ( $V_{SS}$  or  $V_{DD}$ ) unless otherwise specified.

Symbol	Pin	Type	Description
$V_{SS}$	20	supply	ground supply voltage
$V_{LCD}$	21	supply	LCD supply voltage
BP0 to BP3	22 to 25	output	LCD backplane outputs
S0 to S22, S23 to S31	26 to 48, 1 to 9	output	LCD segment outputs

## 6 Functional description

The PCA85262 is a versatile peripheral device designed to interface between any microcontroller to a wide variety of LCD segment or dot-matrix displays. It can directly drive any static or multiplexed LCD containing up to four backplanes and up to 32 segments.

### 6.1 Commands of PCA85262

The commands available to the PCA85262 are defined in [Table 4](#).

Table 4. Definition of the PCA85262 commands

Bit position labeled as - is not used.

Command	Operation code								Reference	
	7	6	5	4	3	2	1	0		
mode-set	C	1	0	-	E	B	M[1:0]		<a href="#">Table 6</a>	
load-data-pointer	C	0	0	P[4:0]						<a href="#">Table 7</a>
device-select	C	1	1	0	0	0	A[1:0]		<a href="#">Table 8</a>	
bank-select	C	1	1	1	1	0	I	O	<a href="#">Table 9</a>	
blink-select	C	1	1	1	0	AB	BF[1:0]		<a href="#">Table 10</a>	

All available commands carry a continuation bit C in their most significant bit position as shown in [Figure 21](#). When this bit is set logic 1, it indicates that the next byte of the transfer to arrive will also represent a command. If this bit is set logic 0, it indicates that the command byte is the last in the transfer. Further bytes are regarded as display data (see [Table 5](#)).

Table 5. C bit description

Bit	Symbol	Value	Description
7	C		<b>continue bit</b>
		0	last control byte in the transfer; next byte will be regarded as display data
		1	control bytes continue; next byte will be a command too

### 6.1.1 Command: mode-set

The mode-set command allows configuring the multiplex mode, the bias levels and enabling or disabling the display.

Table 6. Mode-set command bit description

Bit	Symbol	Value	Description
7	C	0, 1	see <a href="#">Table 5</a>
6 to 5	-	10	fixed value
4	-	-	unused
3	E		<b>display status</b> <sup>[1]</sup>
		0	disabled (blank) <sup>[2]</sup>
		1	enabled
2	B		<b>LCD bias configuration</b> <sup>[3]</sup>
		0	$\frac{1}{3}$ bias
		1	$\frac{1}{2}$ bias
1 to 0	M[1:0]		<b>LCD drive mode selection</b>
		01	static; BP0
		10	1:2 multiplex; BP0, BP1
		11	1:3 multiplex; BP0, BP1, BP2
		00	1:4 multiplex; BP0, BP1, BP2, BP3

[1] The possibility to disable the display allows implementation of blinking under external control.

[2] The display is disabled by setting all backplane and segment outputs to  $V_{LCD}$ .

[3] Not applicable for static drive mode.

### 6.1.2 Command: load-data-pointer

The load-data-pointer command defines the display RAM address where the following display data are sent to.

Table 7. Load-data-pointer command bit description

See [Section 6.3.1](#).

Bit	Symbol	Value	Description
7	C	0, 1	see <a href="#">Table 5</a>
6 to 5	-	00	fixed value
4 to 0	P[4:0]	0 0000 to 1 1111	5-bit binary value, 0 to 31; transferred to the data pointer to define one of 32 display RAM addresses

### 6.1.3 Command: device-select

The device-select command allows defining the subaddress counter value.

Table 8. Device-select command bit description

See [Section 6.3.2](#).

Bit	Symbol	Value	Description
7	C	0, 1	see <a href="#">Table 5</a>
6 to 2	-	110 00	fixed value
1 to 0	A[1:0]	00 to 11	2-bit binary value, 0 to 3; transferred to the subaddress counter to define one of four hardware subaddresses

### 6.1.4 Command: bank-select

The bank-select command controls where data is written to RAM and where it is displayed from.

Table 9. Bank-select command bit description

See [Section 6.3.5](#).

Bit	Symbol	Value	Description	
			Static	1:2 multiplex <sup>[1]</sup>
7	C	0, 1	see <a href="#">Table 5</a>	
6 to 2	-	111 10	fixed value	
1	I		<b>input bank selection</b> ; storage of arriving display data	
		0	RAM row 0	RAM rows 0 and 1
		1	RAM row 2	RAM rows 2 and 3
0	O		<b>output bank selection</b> ; retrieval of LCD display data	
		0	RAM row 0	RAM rows 0 and 1
		1	RAM row 2	RAM rows 2 and 3

[1] The bank-select command has no effect in 1:3 and 1:4 multiplex drive modes.

### 6.1.5 Command: blink-select

The blink-select command allows configuring the blink mode and the blink frequency.

Table 10. Blink-select command bit description

See [Section 6.1.5.1](#).

Bit	Symbol	Value	Description
7	C	0, 1	see <a href="#">Table 5</a>
6 to 3	-	111 0	fixed value
2	AB		<b>blink mode selection</b>
		0	normal blinking <sup>[1]</sup>
		1	alternate RAM bank blinking <sup>[2]</sup>
1 to 0	BF[1:0]		<b>blink frequency selection</b>
		00	off
		01	1
		10	2

**Table 10. Blink-select command bit description...continued**

See [Section 6.1.5.1](#).

Bit	Symbol	Value	Description
		11	3

[1] Normal blinking is assumed when the LCD multiplex drive modes 1:3 or 1:4 are selected.

[2] Alternate RAM bank blinking does not apply in 1:3 and 1:4 multiplex drive modes.

### 6.1.5.1 Blinking

The display blinking capabilities of the PCA85262 are very versatile. The whole display can blink at frequencies selected by the blink-select command (see [Table 10](#)). The blink frequencies are derived from the clock frequency. The ratio between the clock and blink frequencies depends on the blink mode selected (see [Table 11](#)).

An additional feature is for an arbitrary selection of LCD segments/elements to blink. This applies to the static and 1:2 multiplex drive modes and can be implemented without any communication overheads. With the output bank selector, the displayed RAM banks are exchanged with alternate RAM banks at the blink frequency. This mode can also be specified by the blink-select command.

In the 1:3 and 1:4 multiplex modes, where no alternative RAM bank is available, groups of LCD segments/elements can blink by selectively changing the display RAM data at fixed time intervals.

The entire display can blink at a frequency other than the nominal blink frequency. This can be effectively performed by resetting and setting the display enable bit E at the required rate using the mode-set command (see [Table 6](#)).

**Table 11. Blink frequencies**

Blink mode	Blink frequency equation <sup>[1]</sup>
off	-
1	$f_{blink} = \frac{f_{clk}}{768}$
2	$f_{blink} = \frac{f_{clk}}{1536}$
3	$f_{blink} = \frac{f_{clk}}{3072}$

[1] The blink frequency is proportional to the clock frequency ( $f_{clk}$ ). For the range of the clock frequency, see [Table 19](#).

## 6.2 Clock and frame frequency

### 6.2.1 Internal clock

The internal logic of the PCA85262 and its LCD drive signals are timed either by its internal oscillator or by an external clock. The internal oscillator is enabled by connecting pin OSC to pin V<sub>SS</sub>. If the internal oscillator is used, the output from pin CLK can be used as the clock signal for several PCA85262 in the system that are connected in cascade.

6.2.2 External clock

Pin CLK is enabled as an external clock input by connecting pin OSC to V<sub>DD</sub>. The LCD frame frequency is determined by the clock frequency (f<sub>clk</sub>).

**Remark:** A clock signal must always be supplied to the device; removing the clock may freeze the LCD in a DC state, which is not suitable for the liquid crystal.

6.2.3 Timing

The PCA85262 timing controls the internal data flow of the device. This includes the transfer of display data from the display RAM to the display segment outputs. In cascaded applications, the correct timing relationship between each PCA85262 in the system is maintained by the synchronization signal at pin SYNC. The timing also generates the LCD frame frequency signal. The frame frequency signal is a fixed division

of the clock frequency from either the internal or an external clock:  $f_{fr} = \frac{f_{clk}}{24}$

6.3 Display RAM

The display RAM is a static 32 x 4-bit RAM which stores LCD data.

There is a one-to-one correspondence between

- the bits in the RAM bitmap and the LCD segments/elements
- the RAM columns and the segment outputs
- the RAM rows and the backplane outputs.

A logic 1 in the RAM bitmap indicates the on-state of the corresponding LCD element; similarly, a logic 0 indicates the off-state.

The display RAM bitmap, [Figure 3](#), shows the rows 0 to 3 which correspond with the backplane outputs BP0 to BP3, and the columns 0 to 31 which correspond with the segment outputs S0 to S31. In multiplexed LCD applications the segment data of the first, second, third, and fourth row of the display RAM are time-multiplexed with BP0, BP1, BP2, and BP3 respectively.

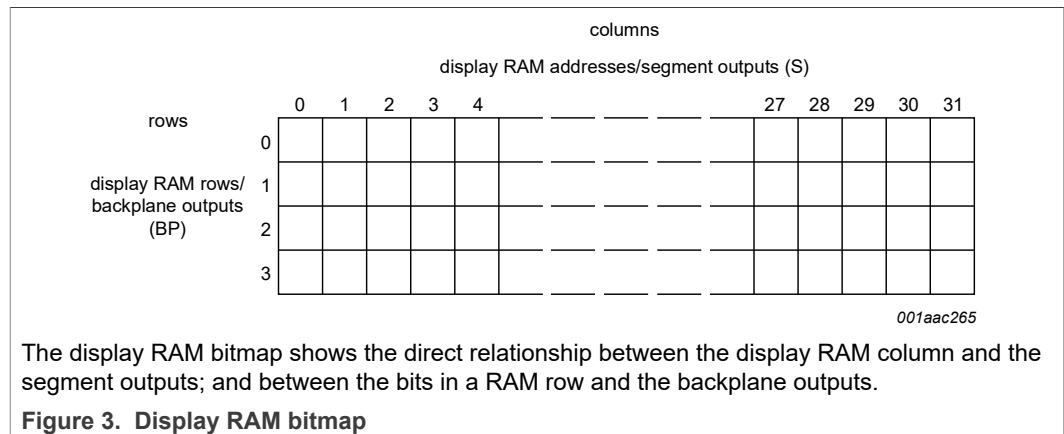

When display data is transmitted to the PCA85262, the display bytes received are stored in the display RAM in accordance with the selected LCD drive mode. The data is stored as it arrives and depending on the current multiplex drive mode the bits are stored singularly, in pairs, triples or quadruples. To illustrate the filling order, an example of a 7-

segment numeric display showing all drive modes is given in [Figure 4](#); the RAM filling organization depicted applies equally to other LCD types.

- In static drive mode the eight transmitted data bits are placed into row 0 as one byte
- In 1:2 multiplex drive mode the eight transmitted data bits are placed in pairs into row 0 and 1 as four successive 2-bit RAM words
- In 1:3 multiplex drive mode the eight bits are placed in triples into row 0, 1, and 2 as three successive 3-bit RAM words, with bit 3 of the third address left unchanged. It is not recommended to use this bit in a display because of the difficult addressing. This last bit may, if necessary, be controlled by an additional transfer to this address, but care should be taken to avoid overwriting adjacent data because always full bytes are transmitted (see [Section 6.3.4](#))
- In 1:4 multiplex drive mode, the eight transmitted data bits are placed in quadruples into row 0, 1, 2, and 3 as two successive 4-bit RAM words

drive mode	LCD segments	LCD backplanes	display RAM filling order	transmitted display byte																																																									
static			<p>columns display RAM address/segment outputs (s) byte1</p> <table border="1"> <tr> <td></td> <td>n</td> <td>n + 1</td> <td>n + 2</td> <td>n + 3</td> <td>n + 4</td> <td>n + 5</td> <td>n + 6</td> <td>n + 7</td> </tr> <tr> <td>rows display RAM rows/backplane outputs (BP)</td> <td>0</td> <td>c</td> <td>b</td> <td>a</td> <td>f</td> <td>g</td> <td>e</td> <td>d</td> <td>DP</td> </tr> <tr> <td>1</td> <td>x</td> <td>x</td> <td>x</td> <td>x</td> <td>x</td> <td>x</td> <td>x</td> <td>x</td> <td>x</td> </tr> <tr> <td>2</td> <td>x</td> <td>x</td> <td>x</td> <td>x</td> <td>x</td> <td>x</td> <td>x</td> <td>x</td> <td>x</td> </tr> <tr> <td>3</td> <td>x</td> <td>x</td> <td>x</td> <td>x</td> <td>x</td> <td>x</td> <td>x</td> <td>x</td> <td>x</td> </tr> </table>		n	n + 1	n + 2	n + 3	n + 4	n + 5	n + 6	n + 7	rows display RAM rows/backplane outputs (BP)	0	c	b	a	f	g	e	d	DP	1	x	x	x	x	x	x	x	x	x	2	x	x	x	x	x	x	x	x	x	3	x	x	x	x	x	x	x	x	x	<p>MSB</p> <table border="1"> <tr> <td>c</td> <td>b</td> <td>a</td> <td>f</td> <td>g</td> <td>e</td> <td>d</td> <td>DP</td> </tr> </table> <p>LSB</p>	c	b	a	f	g	e	d	DP
	n	n + 1	n + 2	n + 3	n + 4	n + 5	n + 6	n + 7																																																					
rows display RAM rows/backplane outputs (BP)	0	c	b	a	f	g	e	d	DP																																																				
1	x	x	x	x	x	x	x	x	x																																																				
2	x	x	x	x	x	x	x	x	x																																																				
3	x	x	x	x	x	x	x	x	x																																																				
c	b	a	f	g	e	d	DP																																																						
1:2 multiplex			<p>columns display RAM address/segment outputs (s) byte1</p> <table border="1"> <tr> <td></td> <td>n</td> <td>n + 1</td> <td>n + 2</td> <td>n + 3</td> </tr> <tr> <td>rows display RAM rows/backplane outputs (BP)</td> <td>0</td> <td>a</td> <td>f</td> <td>e</td> <td>d</td> </tr> <tr> <td>1</td> <td>b</td> <td>g</td> <td>c</td> <td>DP</td> <td></td> </tr> <tr> <td>2</td> <td>x</td> <td>x</td> <td>x</td> <td>x</td> <td></td> </tr> <tr> <td>3</td> <td>x</td> <td>x</td> <td>x</td> <td>x</td> <td></td> </tr> </table>		n	n + 1	n + 2	n + 3	rows display RAM rows/backplane outputs (BP)	0	a	f	e	d	1	b	g	c	DP		2	x	x	x	x		3	x	x	x	x		<p>MSB</p> <table border="1"> <tr> <td>a</td> <td>b</td> <td>f</td> <td>g</td> <td>e</td> <td>c</td> <td>d</td> <td>DP</td> </tr> </table> <p>LSB</p>	a	b	f	g	e	c	d	DP																				
	n	n + 1	n + 2	n + 3																																																									
rows display RAM rows/backplane outputs (BP)	0	a	f	e	d																																																								
1	b	g	c	DP																																																									
2	x	x	x	x																																																									
3	x	x	x	x																																																									
a	b	f	g	e	c	d	DP																																																						
1:3 multiplex			<p>columns display RAM address/segment outputs (s) byte1</p> <table border="1"> <tr> <td></td> <td>n</td> <td>n + 1</td> <td>n + 2</td> </tr> <tr> <td>rows display RAM rows/backplane outputs (BP)</td> <td>0</td> <td>b</td> <td>a</td> <td>f</td> </tr> <tr> <td>1</td> <td>DP</td> <td>d</td> <td>e</td> <td></td> </tr> <tr> <td>2</td> <td>c</td> <td>g</td> <td>x</td> <td></td> </tr> <tr> <td>3</td> <td>x</td> <td>x</td> <td>x</td> <td></td> </tr> </table>		n	n + 1	n + 2	rows display RAM rows/backplane outputs (BP)	0	b	a	f	1	DP	d	e		2	c	g	x		3	x	x	x		<p>MSB</p> <table border="1"> <tr> <td>b</td> <td>DP</td> <td>c</td> <td>a</td> <td>d</td> <td>g</td> <td>f</td> <td>e</td> </tr> </table> <p>LSB</p>	b	DP	c	a	d	g	f	e																									
	n	n + 1	n + 2																																																										
rows display RAM rows/backplane outputs (BP)	0	b	a	f																																																									
1	DP	d	e																																																										
2	c	g	x																																																										
3	x	x	x																																																										
b	DP	c	a	d	g	f	e																																																						
1:4 multiplex			<p>columns display RAM address/segment outputs (s) byte1</p> <table border="1"> <tr> <td></td> <td>n</td> <td>n + 1</td> </tr> <tr> <td>rows display RAM rows/backplane outputs (BP)</td> <td>0</td> <td>a</td> <td>f</td> </tr> <tr> <td>1</td> <td>c</td> <td>e</td> <td></td> </tr> <tr> <td>2</td> <td>b</td> <td>g</td> <td></td> </tr> <tr> <td>3</td> <td>DP</td> <td>d</td> <td></td> </tr> </table>		n	n + 1	rows display RAM rows/backplane outputs (BP)	0	a	f	1	c	e		2	b	g		3	DP	d		<p>MSB</p> <table border="1"> <tr> <td>a</td> <td>c</td> <td>b</td> <td>DP</td> <td>f</td> <td>e</td> <td>g</td> <td>d</td> </tr> </table> <p>LSB</p>	a	c	b	DP	f	e	g	d																														
	n	n + 1																																																											
rows display RAM rows/backplane outputs (BP)	0	a	f																																																										
1	c	e																																																											
2	b	g																																																											
3	DP	d																																																											
a	c	b	DP	f	e	g	d																																																						

001aa|646

x = data bit unchanged.

Figure 4. Relationship between LCD layout, drive mode, display RAM filling order, and display data transmitted over the I<sup>2</sup>C-bus

### 6.3.1 Data pointer

The addressing mechanism for the display RAM is realized using the data pointer. This allows the loading of an individual display data byte, or a series of display data bytes, into any location of the display RAM. The sequence commences with the initialization of the data pointer by the load-data-pointer command (see [Table 7](#)). Following this command, an arriving data byte is stored at the display RAM address indicated by the data pointer. The filling order is shown in [Figure 4](#).

After each byte is stored, the content of the data pointer is automatically incremented by a value dependent on the selected LCD drive mode:

- In static drive mode by eight
- In 1:2 multiplex drive mode by four
- In 1:3 multiplex drive mode by three
- In 1:4 multiplex drive mode by two

If an I<sup>2</sup>C-bus data access terminates early, then the state of the data pointer is unknown. Consequently, the data pointer must be rewritten prior to further RAM accesses.

### 6.3.2 Subaddress counter

The storage of display data is determined by the contents of the subaddress counter. Storage is allowed only when the content of the subaddress counter matches with the hardware subaddress applied to A0 and A1. The subaddress counter value is defined by the device-select command (see [Table 8](#)). If the content of the subaddress counter and the hardware subaddress do not match, then data storage is inhibited but the data pointer is incremented as if data storage had taken place. The subaddress counter is also incremented when the data pointer overflows.

### 6.3.3 RAM addressing in cascaded applications

In cascaded applications each PCA85262 in the cascade must be addressed separately. Initially, the first PCA85262 is selected by sending the device-select command matching the first device's hardware subaddress. Then the data pointer is set to the preferred display RAM address by sending the load-data-pointer command.

Once the display RAM of the first PCA85262 has been written, the second PCA85262 is selected by sending the device-select command again. This time however the command matches the second device's hardware subaddress. Next the load-data-pointer command is sent to select the preferred display RAM address of the second PCA85262.

This last step is very important because during writing data to the first PCA85262, the data pointer of the second PCA85262 is incremented. In addition, the hardware subaddress should not be changed while the device is being accessed on the I<sup>2</sup>C-bus interface.

### 6.3.4 RAM writing in 1:3 multiplex drive mode

In 1:3 multiplex drive mode, the RAM is written as shown in [Table 12](#) (see [Figure 4](#) as well).

**Table 12. Standard RAM filling in 1:3 multiplex drive mode**

Assumption: BP2/S2, BP2/S5, BP2/S8 etc. **are not connected** to any segments/elements on the display.

Display RAM bits (rows)/ backplane outputs (BPn)	Display RAM addresses (columns)/segment outputs (Sn)										
	0	1	2	3	4	5	6	7	8	9	:
0	a7	a4	a1	b7	b4	b1	c7	c4	c1	d7	:
1	a6	a3	a0	b6	b3	b0	c6	c3	c0	d6	:
2	a5	a2	-	b5	b2	-	c5	c2	-	d5	:
3	-	-	-	-	-	-	-	-	-	-	:

If the bit at position BP2/S2 would be written by a second byte transmitted, then the mapping of the segment bits would change as illustrated in [Table 13](#).

**Table 13. Entire RAM filling by rewriting in 1:3 multiplex drive mode**

Assumption: BP2/S2, BP2/S5, BP2/S8 etc. **are connected** to segments/elements on the display.

Display RAM bits (rows)/ backplane outputs (BPn)	Display RAM addresses (columns)/segment outputs (Sn)										
	0	1	2	3	4	5	6	7	8	9	:
0	a7	a4	a1/b7	b4	b1/c7	c4	c1/d7	d4	d1/e7	e4	:
1	a6	a3	a0/b6	b3	b0/c6	c3	c0/d6	d3	d0/e6	e3	:
2	a5	a2	b5	b2	c5	c2	d5	d2	e5	e2	:
3	-	-	-	-	-	-	-	-	-	-	:

In the case described in [Table 13](#) the RAM has to be written entirely and BP2/S2, BP2/S5, BP2/S8 etc. have to be connected to segments/elements on the display. This can be achieved by a combination of writing and rewriting the RAM like follows:

- In the first write to the RAM, bits a7 to a0 are written
- The data-pointer (see [Section 6.3.1](#)) has to be set to the address of bit a1
- In the second write, bits b7 to b0 are written, overwriting bits a1 and a0 with bits b7 and b6
- The data-pointer has to be set to the address of bit b1
- In the third write, bits c7 to c0 are written, overwriting bits b1 and b0 with bits c7 and c6

Depending on the method of writing to the RAM (standard or entire filling by rewriting), some segments/elements remain unused or can be used, but it has to be considered in the module layout process as well as in the driver software design.

### 6.3.5 Bank selection

#### 6.3.5.1 Output bank selector

The output bank selector (see [Table 9](#)) selects one of the four rows per display RAM address for transfer to the display register. The actual row selected depends on the particular LCD drive mode in operation and on the instant in the multiplex sequence.

- In 1:4 multiplex mode, all RAM addresses of row 0 are selected, these are followed by the contents of row 1, 2, and then 3
- In 1:3 multiplex mode, rows 0, 1, and 2 are selected sequentially
- In 1:2 multiplex mode, rows 0 and 1 are selected
- In static mode, row 0 is selected

**6.3.5.2 Input bank selector**

The input bank selector loads display data into the display RAM in accordance with the selected LCD drive configuration. Display data can be loaded in row 2 in static drive mode or in rows 2 and 3 in 1:2 multiplex drive mode by using the bank-select command (see [Table 9](#)). The input bank selector functions independently to the output bank selector.

**6.3.5.3 RAM bank switching**

The PCA85262 includes a RAM bank switching feature in the static and 1:2 multiplex drive modes. A bank can be thought of as one RAM row or a collection of RAM rows (see [Figure 5](#)). The RAM bank switching gives the provision for preparing display information in an alternative bank and to be able to switch to it once it is complete.

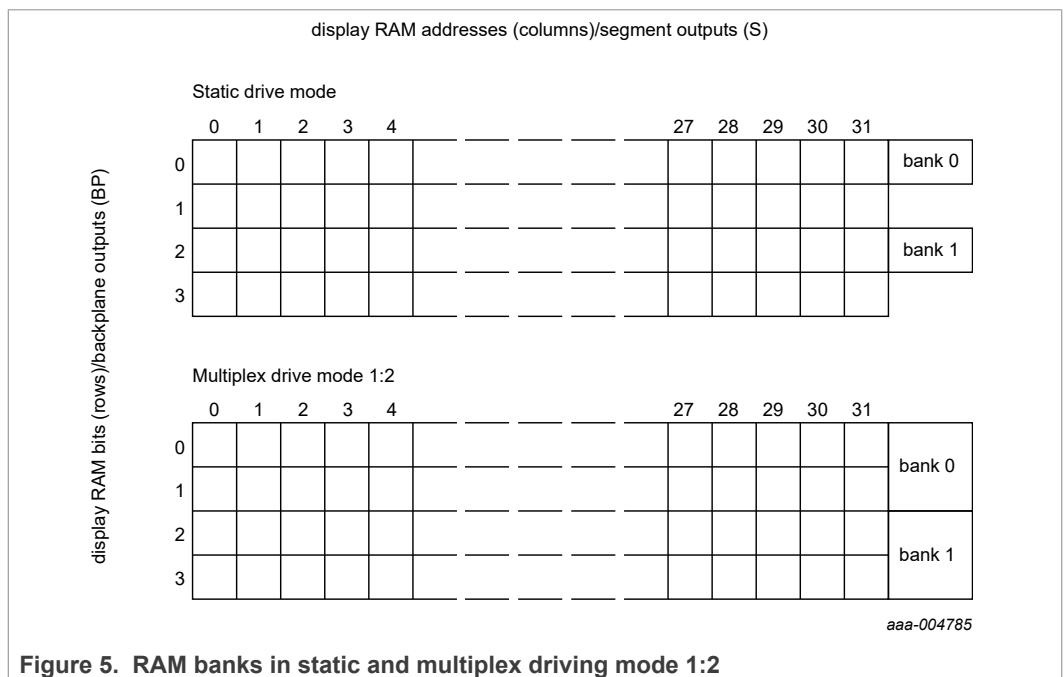

**Figure 5. RAM banks in static and multiplex driving mode 1:2**

There are two banks; bank 0 and bank 1. [Figure 5](#) shows the location of these banks relative to the RAM map. Input and output banks can be set independently from one another with the Bank-select command (see [Table 9](#)). [Figure 6](#) shows the concept.

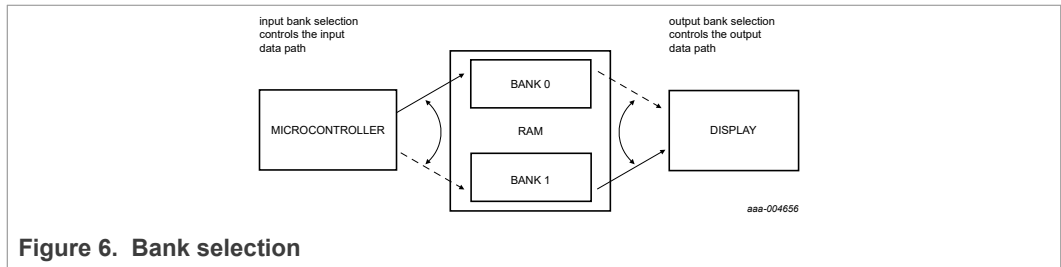

Figure 6. Bank selection

In the static drive mode, the bank-select command may request the contents of row 2 to be selected for display instead of the contents of row 0. In the 1:2 multiplex mode, the contents of rows 2 and 3 may be selected instead of rows 0 and 1. This gives the provision for preparing display information in an alternative bank and to be able to switch to it once it is assembled.

In [Figure 7](#) an example is shown for 1:2 multiplex drive mode where the displayed data is read from the first two rows of the memory (bank 0), while the transmitted data is stored in the second two rows of the memory (bank 1).

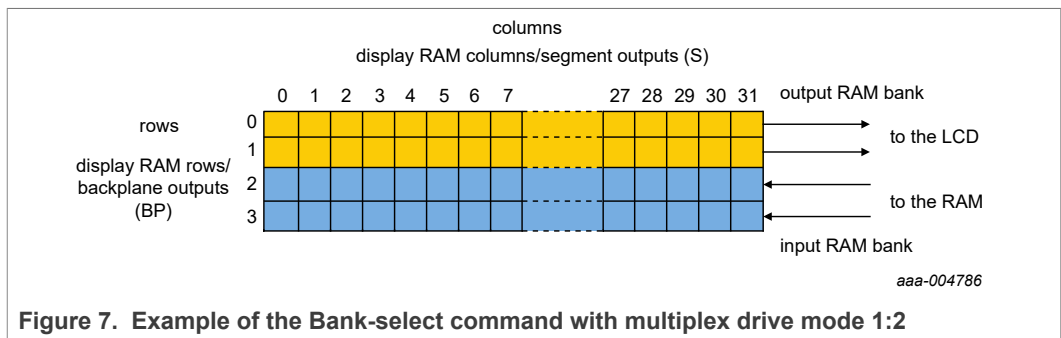

Figure 7. Example of the Bank-select command with multiplex drive mode 1:2

## 6.4 Initialization

At power-on the status of the I<sup>2</sup>C-bus and the registers of the PCA85262 is undefined. Therefore the PCA85262 should be initialized as quickly as possible after power-on to ensure a proper bus communication and to avoid display artifacts. The following instructions should be accomplished for initialization:

### 6.4.1 Device initialization

At power-on the status of the I<sup>2</sup>C-bus communication interface is undefined since this device doesn't have POR which was removed to improve the ESD performance. A START and STOP condition with dummy byte in-between must be sent after every power reset to set up the I<sup>2</sup>C-bus communication interface.

- I<sup>2</sup>C-bus (see [Section 7](#)) initialization
  - generating a START condition
  - sending 0h (1 byte) and ignoring the acknowledge – Note, this is not the device address but just a dummy byte of all zeros
  - generating a STOP condition

6.4.2 Device setup

At power-on the status of the display and configuration registers are undefined and need to be set up to properly display information on the LCD display. After the I<sup>2</sup>C-bus interface is initialized as discussed in [Section 6.4.1](#) set up the device using these register settings

- Mode-set command (see [Table 6](#)), setting
  - bit E = 0
  - bit B to the required LCD bias configuration
  - bits M[1:0] to the required LCD drive mode
- Load-data-pointer command (see [Table 7](#)), setting
  - bits P[4:0] to 0h (or any other required address)
- Device-select command (see [Table 8](#)), setting
  - bits A[1:0] to the required hardware subaddress (for example, 0h)
- Bank-select command (see [Table 9](#)), setting
  - bit I to 0
  - bit O to 0
- Blink-select command (see [Table 10](#)), setting
  - bit AB to 0 or 1
  - bits BF[1:0] to 00 (or to a desired blinking mode)
- writing meaningful information (for example, a logo) into the display RAM
- After the initialization, the display can be switched on by setting bit E = 1 with the mode-set command or left off (blank) with bit E = 0.

6.5 Possible display configurations

The possible display configurations of the PCA85262 depend on the number of active backplane outputs required. A selection of display configurations is shown in [Table 14](#). All of these configurations can be implemented in the typical system shown in [Figure 9](#).

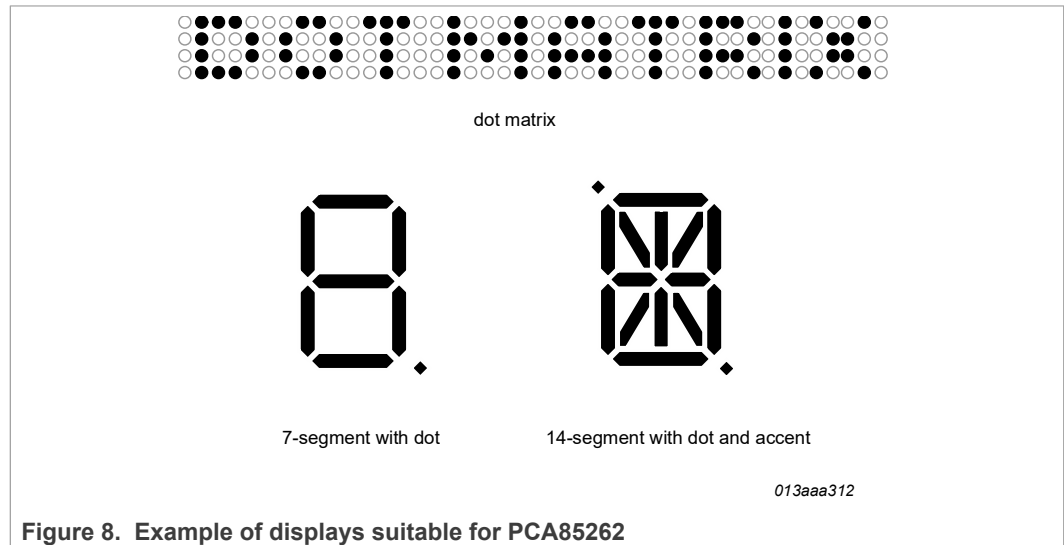
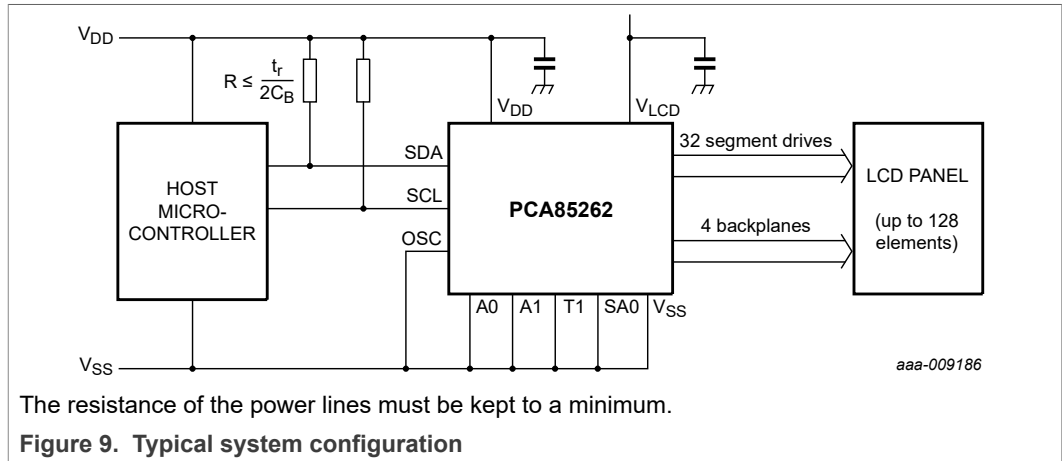

Table 14. Selection of possible display configurations

Number of Backplanes	Icons	Digits/Characters		Dot matrix: segments/elements
		7-segment <sup>[1]</sup>	14-segment <sup>[2]</sup>	
4	128	16	8	128 dots (4 × 32)
3	96	12	6	96 dots (3 × 32)
2	64	8	4	64 dots (2 × 32)
1	32	4	2	32 dots (1 × 32)

[1] 7 segment display has 8 segments/elements including the decimal point.  
 [2] 14 segment display has 16 segments/elements including decimal point and accent dot.



The host microcontroller maintains the 2-line I<sup>2</sup>C-bus communication channel with the PCA85262. The internal oscillator is enabled by connecting pin OSC to pin V<sub>SS</sub>. The appropriate biasing voltages for the multiplexed LCD waveforms are generated internally. The only other connections required to complete the system are the power supplies (V<sub>DD</sub>, V<sub>SS</sub>, and V<sub>LCD</sub>) and the LCD panel chosen for the application.

### 6.6 LCD bias generator

Fractional LCD biasing voltages are obtained from an internal voltage divider consisting of three impedances connected in series between V<sub>LCD</sub> and V<sub>SS</sub>. The center impedance is bypassed by switch if the 1/2 bias voltage level for the 1:2 multiplex drive mode configuration is selected. The LCD voltage can be temperature compensated externally, using the supply to pin V<sub>LCD</sub>.

### 6.7 LCD voltage selector

The LCD voltage selector coordinates the multiplexing of the LCD in accordance with the selected LCD drive configuration. The operation of the voltage selector is controlled by the mode-set command from the command decoder. The biasing configurations that apply to the preferred modes of operation, together with the biasing characteristics as functions of V<sub>LCD</sub> and the resulting discrimination ratios (D) are given in [Table 15](#).

Discrimination is a term which is defined as the ratio of the on and off RMS voltage across a segment. It can be thought of as a measurement of contrast.

Table 15. Biasing characteristics

LCD drive mode	Number of:		LCD bias configuration	$\frac{V_{off(RMS)}}{V_{LCD}}$	$\frac{V_{on(RMS)}}{V_{LCD}}$	$D = \frac{V_{on(RMS)}}{V_{off(RMS)}}$
	Backplanes	Levels				
static	1	2	static	0	1	$\infty$
1:2 multiplex	2	3	$\frac{1}{2}$	0.354	0.791	2.236
1:2 multiplex	2	4	$\frac{1}{3}$	0.333	0.745	2.236
1:3 multiplex	3	4	$\frac{1}{3}$	0.333	0.638	1.915
1:4 multiplex	4	4	$\frac{1}{3}$	0.333	0.577	1.732

A practical value for  $V_{LCD}$  is determined by equating  $V_{off(RMS)}$  with a defined LCD threshold voltage ( $V_{th(off)}$ ), typically when the LCD exhibits approximately 10 % contrast. In the static drive mode, a suitable choice is  $V_{LCD} > 3V_{th(off)}$ .

Multiplex drive modes of 1:3 and 1:4 with  $\frac{1}{2}$  bias are possible but the discrimination and hence the contrast ratios are smaller.

Bias is calculated by  $\frac{1}{1+a}$ , where the values for a are

- a = 1 for  $\frac{1}{2}$  bias
- a = 2 for  $\frac{1}{3}$  bias

The RMS on-state voltage ( $V_{on(RMS)}$ ) for the LCD is calculated with [Equation 1](#):

$$V_{on(RMS)} = \frac{V_{LCD}}{n} \sqrt{\frac{a^2 + 2a + n}{(1+a)^2}} \quad (1)$$

where the values for n are

- n = 1 for static drive mode
- n = 2 for 1:2 multiplex drive mode
- n = 3 for 1:3 multiplex drive mode
- n = 4 for 1:4 multiplex drive mode

The RMS off-state voltage ( $V_{off(RMS)}$ ) for the LCD is calculated with [Equation 2](#):

$$V_{off(RMS)} = \frac{V_{LCD}}{n} \sqrt{\frac{a^2 - 2a + n}{(1+a)^2}} \quad (2)$$

Discrimination is the ratio of  $V_{on(RMS)}$  to  $V_{off(RMS)}$  and is determined from [Equation 3](#):

$$D = \frac{V_{on(RMS)}}{V_{off(RMS)}} = \sqrt{\frac{a^2 + 2a + n}{a^2 - 2a + n}} \quad (3)$$

Using [Equation 3](#), the discrimination for an LCD drive mode of 1:3 multiplex with  $\frac{1}{2}$  bias is  $\sqrt{3} = 1.732$  and the discrimination for an LCD drive mode of 1:4 multiplex with  $\frac{1}{2}$  bias is  $\frac{\sqrt{21}}{3} = 1.528$ .

The advantage of these LCD drive modes is a reduction of the LCD full scale voltage  $V_{LCD}$  as follows:

- 1:3 multiplex ( $\frac{1}{2}$  bias):  $V_{LCD} = \sqrt{6} \times V_{off(RMS)} = 2.449V_{off(RMS)}$

- 1:4 multiplex ( $\frac{1}{2}$  bias):  $V_{LCD} = \left[ \frac{(4 \times \sqrt{3})}{3} \right] = 2.309V_{off(RMS)}$   
 These compare with  $V_{LCD} = 3V_{off(RMS)}$  when  $\frac{1}{3}$  bias is used.  
 $V_{LCD}$  is sometimes referred as the LCD operating voltage.

**6.7.1 Electro-optical performance**

Suitable values for  $V_{on(RMS)}$  and  $V_{off(RMS)}$  are dependent on the LCD liquid used. The RMS voltage, at which a pixel will be switched on or off, determine the transmissibility of the pixel.

For any given liquid, there are two threshold values defined. One point is at 10 % relative transmission (at  $V_{th(off)}$ ) and the other at 90 % relative transmission (at  $V_{th(on)}$ ), see [Figure 10](#). For a good contrast performance, the following rules should be followed:

$$V_{on(RMS)} \geq V_{th(on)} \quad (4)$$

$$V_{off(RMS)} \leq V_{th(off)} \quad (5)$$

$V_{on(RMS)}$  and  $V_{off(RMS)}$  are properties of the display driver and are affected by the selection of a, n (see [Equation 1](#) to [Equation 3](#)) and the  $V_{LCD}$  voltage.

$V_{th(off)}$  and  $V_{th(on)}$  are properties of the LCD liquid and can be provided by the module manufacturer.  $V_{th(off)}$  is sometimes just named  $V_{th}$ .  $V_{th(on)}$  is sometimes named saturation voltage  $V_{sat}$ .

It is important to match the module properties to those of the driver in order to achieve optimum performance.

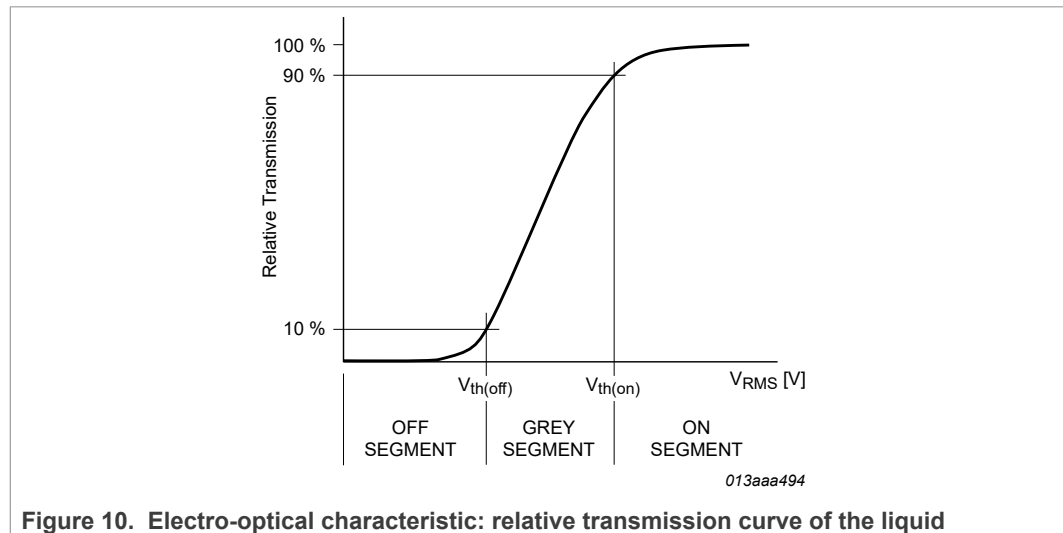
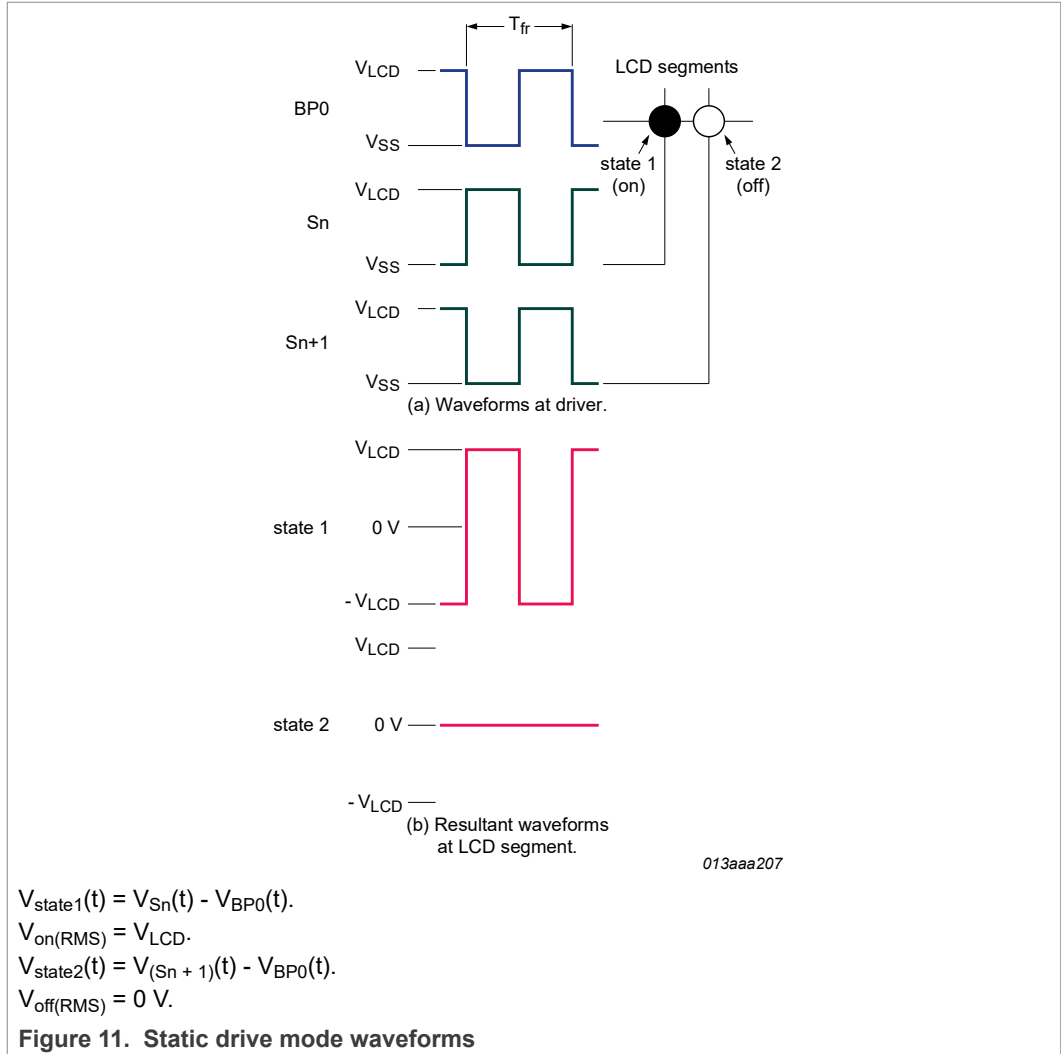

Figure 10. Electro-optical characteristic: relative transmission curve of the liquid

**6.8 LCD drive mode waveforms**

**6.8.1 Static drive mode**

The static LCD drive mode is used when a single backplane is provided in the LCD. The backplane (BPn) and segment (Sn) drive waveforms for this mode are shown in [Figure 11](#).



**6.8.2 1:2 Multiplex drive mode**

When two backplanes are provided in the LCD, the 1:2 multiplex mode applies. The PCA85262 allows the use of  $\frac{1}{2}$  bias or  $\frac{1}{3}$  bias in this mode as shown in [Figure 12](#) and [Figure 13](#).

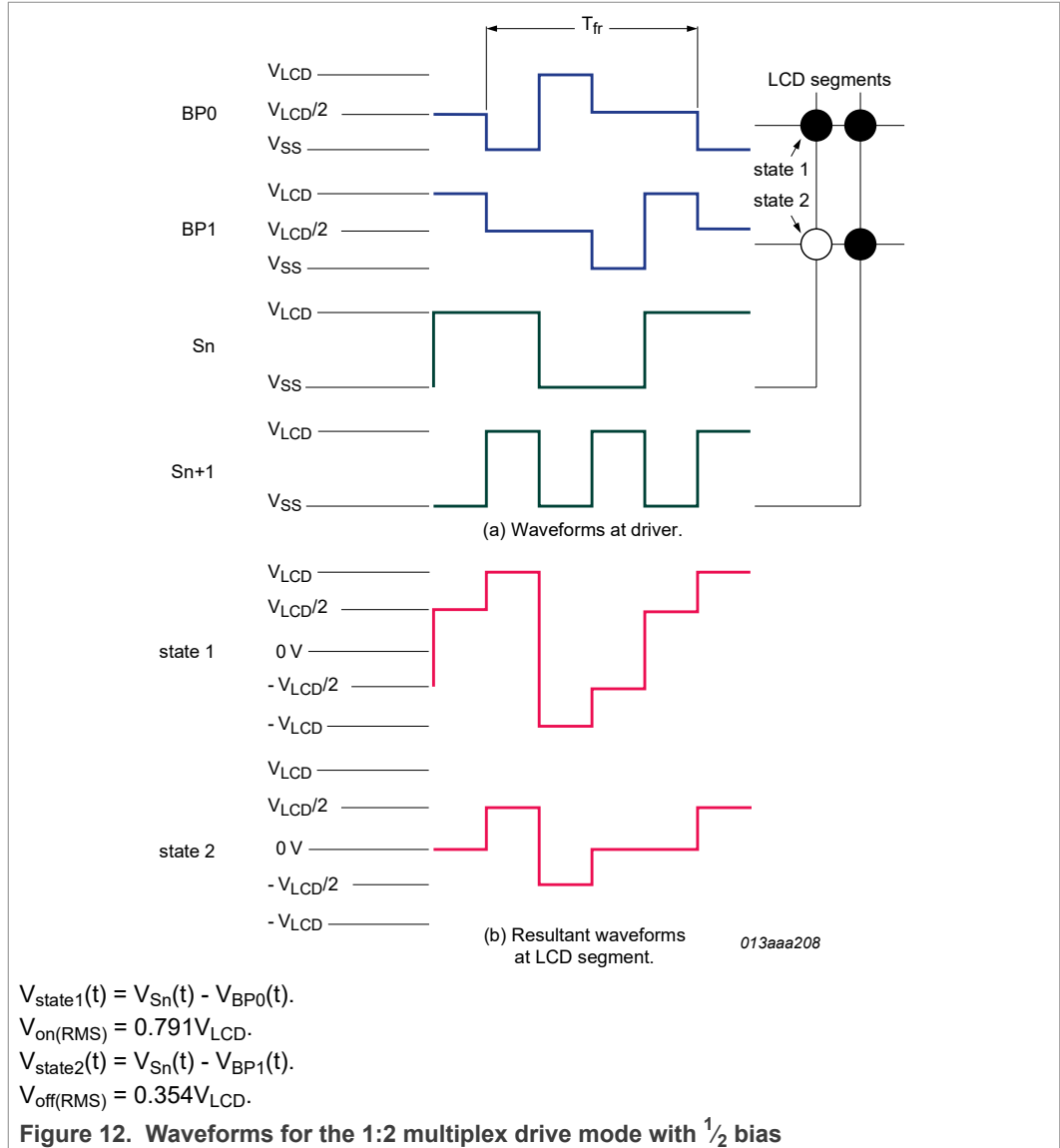

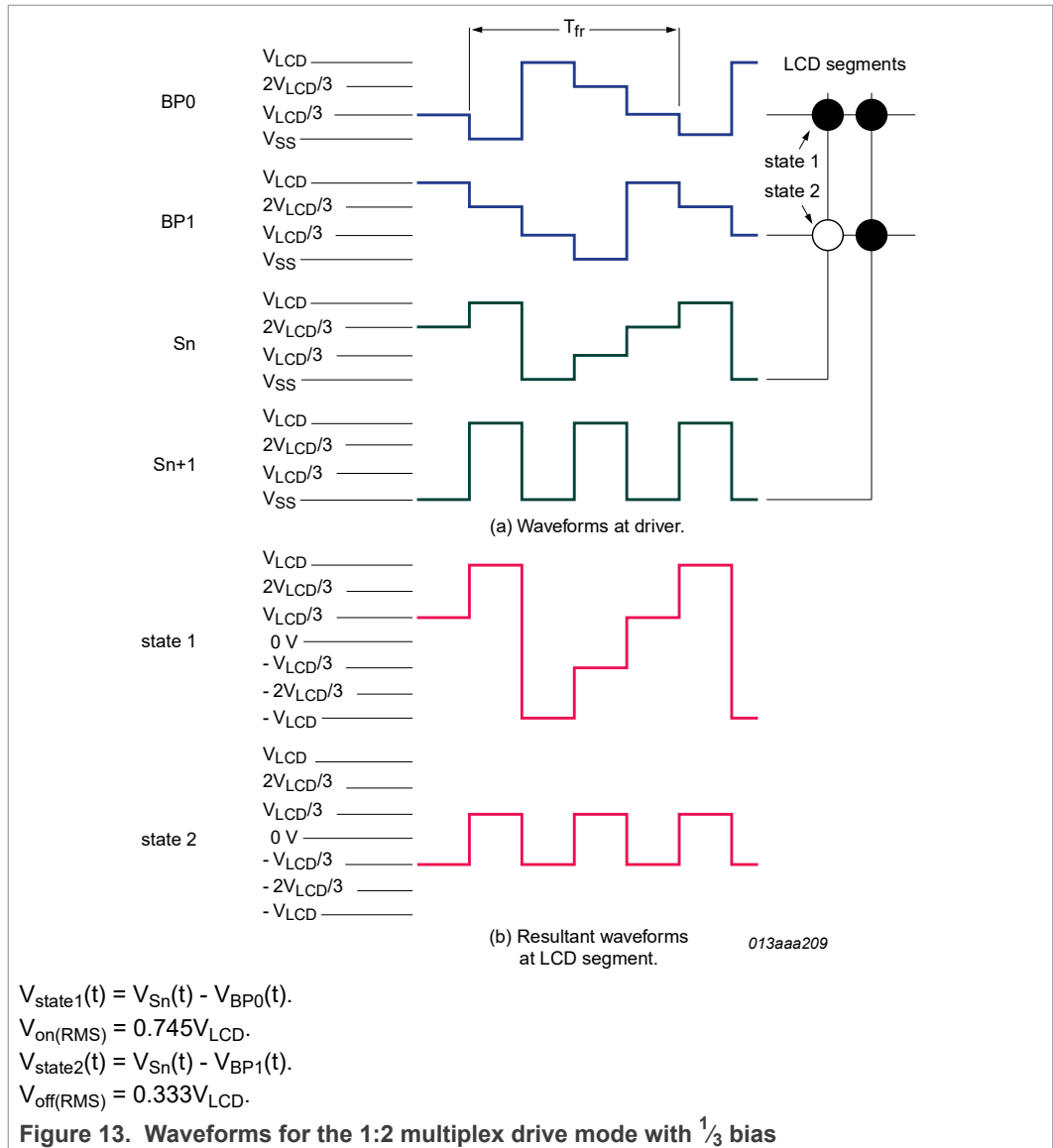

**6.8.3 1:3 Multiplex drive mode**

When three backplanes are provided in the LCD, the 1:3 multiplex drive mode applies, as shown in [Figure 14](#).

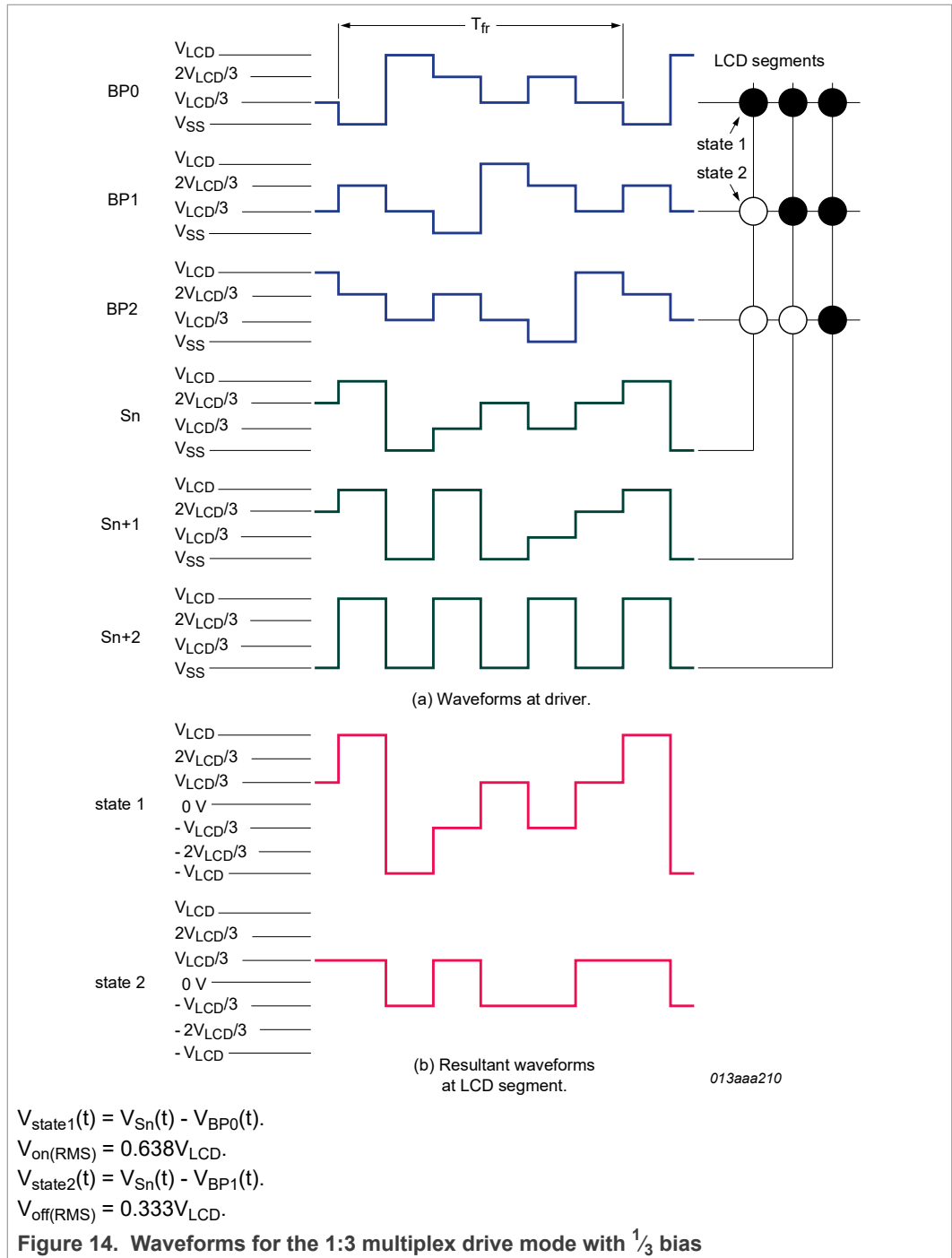

6.8.4 1:4 Multiplex drive mode

When four backplanes are provided in the LCD, the 1:4 multiplex drive mode applies as shown in [Figure 15](#).

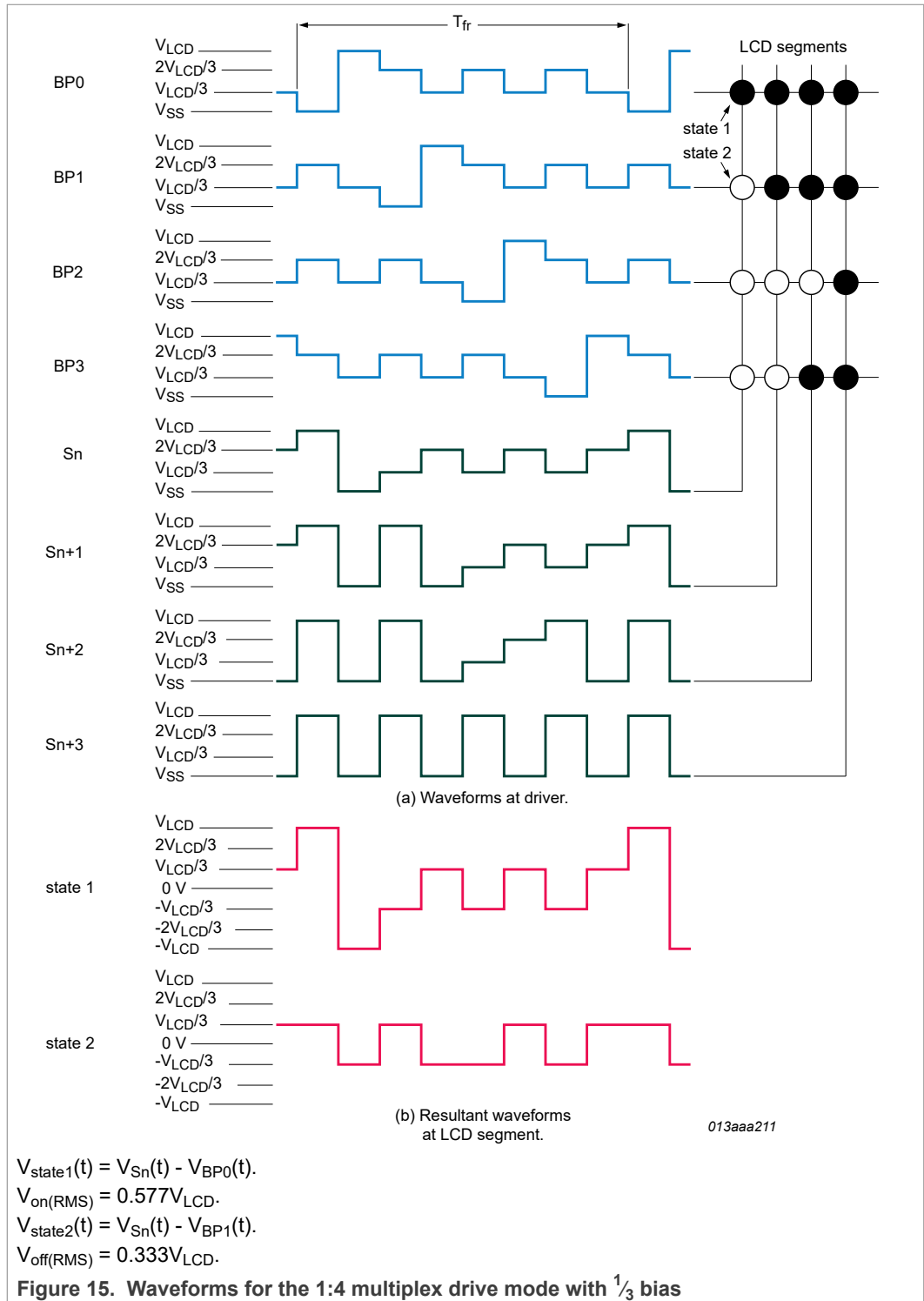

### 6.9 Backplane and segment outputs

**6.9.1 Backplane outputs**

The LCD drive section includes four backplane outputs BP0 to BP3 which must be connected directly to the LCD. The backplane output signals are generated in accordance with the selected LCD drive mode. If less than four backplane outputs are required, the unused outputs can be left open-circuit.

- In 1:3 multiplex drive mode, BP3 carries the same signal as BP1, therefore these two adjacent outputs can be tied together to give enhanced drive capabilities
- In 1:2 multiplex drive mode, BP0 and BP2, respectively, BP1 and BP3 carry the same signals and may also be paired to increase the drive capabilities
- In static drive mode, the same signal is carried by all four backplane outputs and they can be connected in parallel for very high drive requirements

**6.9.2 Segment outputs**

The LCD drive section includes 32 segment outputs (S0 to S31) which should be connected directly to the LCD. The segment output signals are generated in accordance with the multiplexed backplane signals and with data residing in the display register. When less than 32 segment outputs are required, the unused segment outputs should be left open-circuit.

**7 Characteristics of the I<sup>2</sup>C-bus**

The I<sup>2</sup>C-bus is for bidirectional, two-line communication between different ICs or modules. The two lines are a Serial DATA line (SDA) and a Serial CLOCK line (SCL). Both lines must be connected to a positive supply via a pull-up resistor when connected to the output stages of a device. Data transfer may be initiated only when the bus is not busy.

**7.1 Bit transfer**

One data bit is transferred during each clock pulse. The data on the SDA line must remain stable during the HIGH period of the clock pulse as changes in the data line at this time will be interpreted as a control signal (see [Figure 16](#)).

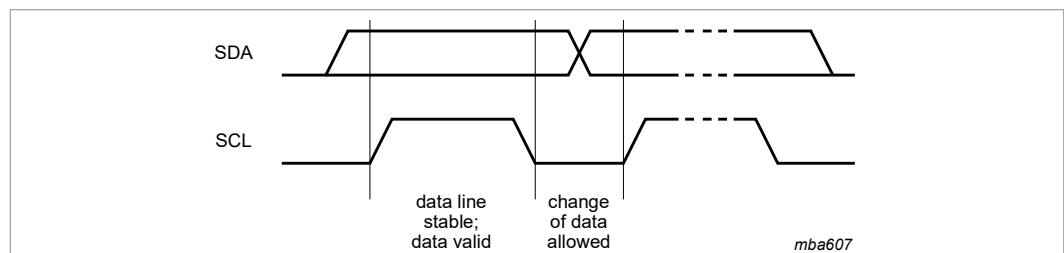

Figure 16. Bit transfer

**7.2 START and STOP conditions**

Both data and clock lines remain HIGH when the bus is not busy.

A HIGH-to-LOW transition of the data line while the clock is HIGH is defined as the START condition - S.

A LOW-to-HIGH transition of the data line while the clock is HIGH is defined as the STOP condition - P.

The START and STOP conditions are illustrated in [Figure 17](#).

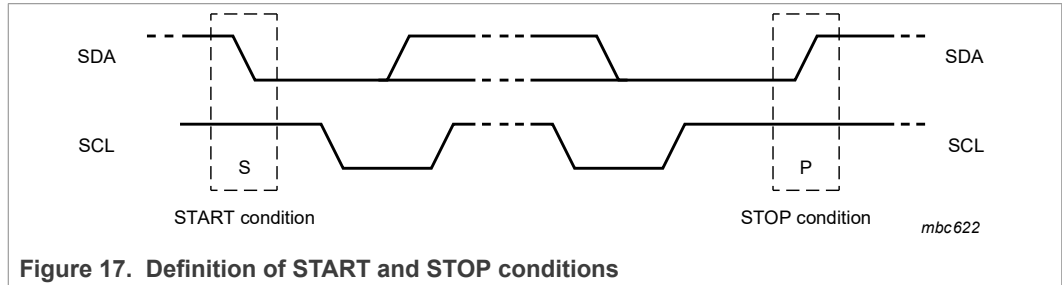

### 7.3 System configuration

A device generating a message is a transmitter, a device receiving a message is the receiver. The device that controls the message is the controller and the devices which are controlled by the controller are the targets. The system configuration is shown in [Figure 18](#).

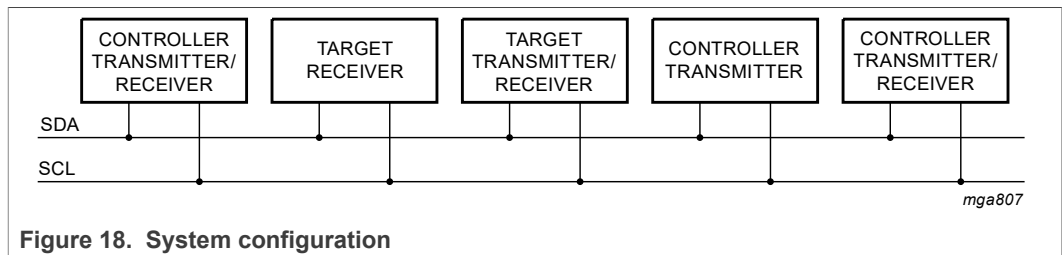

### 7.4 Acknowledge

The number of data bytes transferred between the START and STOP conditions from transmitter to receiver is unlimited. Each byte of eight bits is followed by an acknowledge cycle.

- A target receiver, which is addressed, must generate an acknowledge after the reception of each byte
- A controller receiver must generate an acknowledge after the reception of each byte that has been clocked out of the target transmitter
- The device that acknowledges must pull-down the SDA line during the acknowledge clock pulse, so that the SDA line is stable LOW during the HIGH period of the acknowledge related clock pulse (set-up and hold times must be considered)
- A controller receiver must signal an end of data to the transmitter by not generating an acknowledge on the last byte that has been clocked out of the target. In this event, the transmitter must leave the data line HIGH to enable the controller to generate a STOP condition

Acknowledgement on the I<sup>2</sup>C-bus is illustrated in [Figure 19](#).

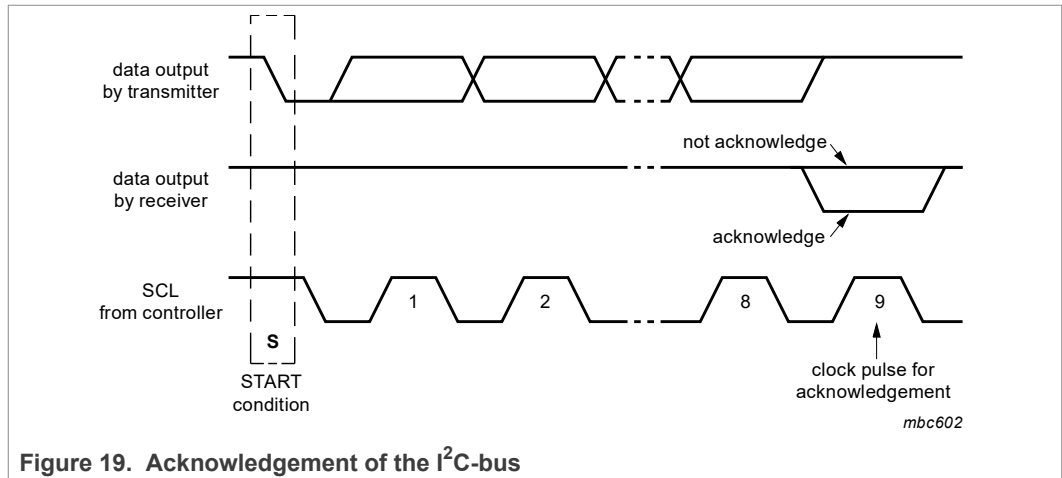

### 7.5 I<sup>2</sup>C-bus controller

The PCA85262 acts as an I<sup>2</sup>C-bus target receiver. It does not initiate I<sup>2</sup>C-bus transfers or transmit data to an I<sup>2</sup>C-bus controller receiver. The only data output from the PCA85262 are the acknowledge signals of the selected devices. Device selection depends on the I<sup>2</sup>C-bus target address, on the transferred command data and on the hardware subaddress.

In single device applications, the hardware subaddress inputs A0 and A1 are normally tied to V<sub>SS</sub> which defines the hardware subaddress 0. In multiple device applications A0 and A1 are tied to V<sub>SS</sub> or V<sub>DD</sub> using a binary coding scheme, so that no two devices with a common I<sup>2</sup>C-bus target address have the same hardware subaddress.

### 7.6 Input filters

To enhance noise immunity in electrically adverse environments, RC low-pass filters are provided on the SDA and SCL lines.

### 7.7 I<sup>2</sup>C-bus protocol

Two I<sup>2</sup>C-bus target addresses (0111 000 and 0111 001) are used to address the PCA85262. The entire I<sup>2</sup>C-bus target address byte is shown in [Table 16](#).

Table 16. I<sup>2</sup>C target address byte

		Target address							
Bit	7	6	5	4	3	2	1	0	
	MSB							LSB	
	0	1	1	1	0	0	SA0	R/W	

The PCA85262 is a write-only device and will not respond to a read access, therefore bit 0 should always be logic 0. Bit 1 of the target address byte that a PCA85262 responds to is defined by the level tied to its SA0 input (V<sub>SS</sub> for logic 0 and V<sub>DD</sub> for logic 1).

Having two reserved target addresses allows the following on the same I<sup>2</sup>C-bus:

- Up to 8 PCA85262 for very large LCD applications
- The use of two types of LCD multiplex drive modes

The I<sup>2</sup>C-bus protocol is shown in [Figure 20](#). The sequence is initiated with a START condition (S) from the I<sup>2</sup>C-bus controller, which is followed by one of the two possible PCA85262 target addresses available. All PCA85262 whose SA0 inputs correspond to bit 0 of the target address respond by asserting an acknowledge in parallel. This I<sup>2</sup>C-bus transfer is ignored by all PCA85262 whose SA0 inputs are set to the alternative level.

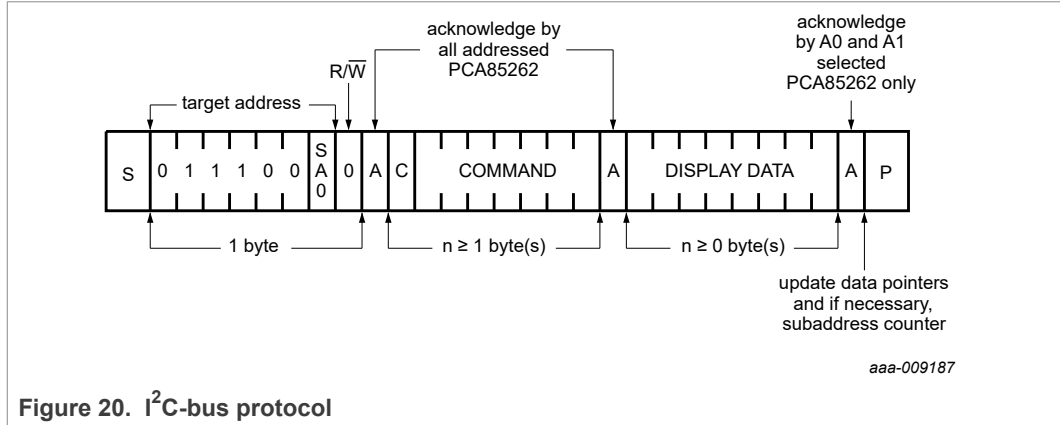

Figure 20. I<sup>2</sup>C-bus protocol

After an acknowledgement, one or more command bytes follow that define the status of each addressed PCA85262.

The last command byte sent is identified by resetting its most significant bit, continuation bit C (see [Figure 21](#)). The command bytes are also acknowledged by all addressed PCA85262 on the bus.

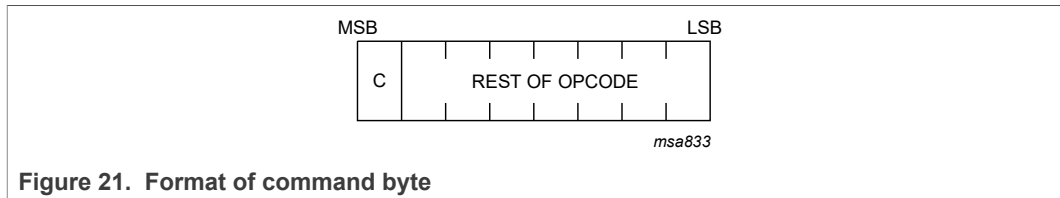
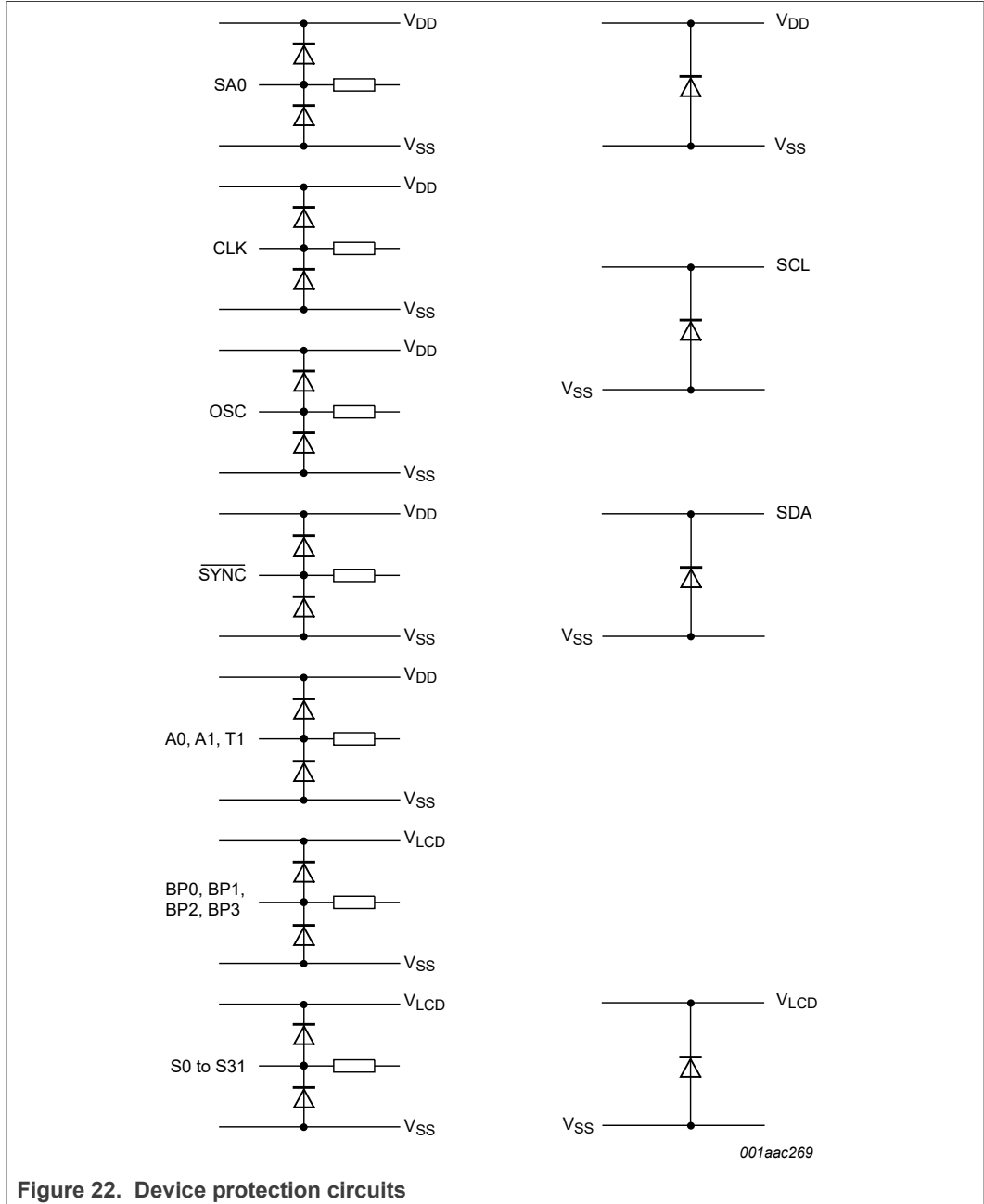

Figure 21. Format of command byte

After the last command byte, one or more display data bytes may follow. Display data bytes are stored in the display RAM at the address specified by the data pointer and the subaddress counter. Both data pointer and subaddress counter are automatically updated and the data directed to the intended PCA85262 device.

An acknowledgement after each byte is asserted only by the PCA85262 that are addressed via address lines A0 and A1. After the last display byte, the I<sup>2</sup>C-bus controller asserts a STOP condition (P). Alternately a START may be asserted to restart an I<sup>2</sup>C-bus access.

### 8 Internal circuitry



### 9 Safety notes

**CAUTION**



This device is sensitive to ElectroStatic Discharge (ESD). Observe precautions for handling electrostatic sensitive devices. Such precautions are described in the *ANSI/ESD S20.20*, *IEC/ST 61340-5*, *JESD625-A* or equivalent standards.

## CAUTION



Static voltages across the liquid crystal display can build up when the LCD supply voltage ( $V_{LCD}$ ) is on while the IC supply voltage ( $V_{DD}$ ) is off, or vice versa. This may cause unwanted display artifacts. To avoid such artifacts,  $V_{LCD}$  and  $V_{DD}$  must be applied or removed together.

## 10 Limiting values

Table 17. Limiting values

In accordance with the Absolute Maximum Rating System (IEC 60134).

Symbol	Parameter	Conditions	Min	Max	Unit
$V_{DD}$	supply voltage		-0.5	+6.5	V
$V_{LCD}$	LCD supply voltage		-0.5	+9.0	V
$V_I$	input voltage	on each of the pins CLK, SDA, SCL, SYNC, SA0, OSC, A0, A1, T1	-0.5	+6.5	V
$V_O$	output voltage	on each of the pins S0 to S31, BP0 to BP3	-0.5	+9.0	V
$I_I$	input current		-10	+10	mA
$I_O$	output current		-10	+10	mA
$I_{DD}$	supply current		-50	+50	mA
$I_{DD(LCD)}$	LCD supply current		-50	+50	mA
$I_{SS}$	ground supply current		-50	+50	mA
$P_{tot}$	total power dissipation		-	400	mW
$P_o$	output power		-	100	mW
$V_{ESD}$	electrostatic discharge voltage	HBM	[1] -	±5 000	V
		CDM	[2] -	±1 500	V
$I_{lu}$	latch-up current	$V_{LU} = 11.5$ V	[3] -	200	mA
$T_{stg}$	storage temperature		[4] -65	+150	°C
$T_{amb}$	ambient temperature	operating device	-40	+105	°C

[1] Pass level; Human Body Model (HBM), according to [1].

[2] Pass level; Charged-Device Model (CDM), according to [2].

[3] Pass level; latch-up testing according to [3] at maximum ambient temperature ( $T_{amb(max)}$ ).

[4] According to the store and transport requirements (see [5]) the devices have to be stored at a temperature of +8 °C to +45 °C and a humidity of 25 % to 75 %.

## 11 Static characteristics

Table 18. Static characteristics

$V_{DD} = 1.8$  V to 5.5 V;  $V_{SS} = 0$  V;  $V_{LCD} = 2.5$  V to 8.0 V;  $T_{amb} = -40$  °C to +105 °C; unless otherwise specified.

Symbol	Parameter	Conditions	Min	Typ	Max	Unit
<b>Supplies</b>						
$V_{DD}$	supply voltage	$V_{LCD} \leq 6.5$ V	1.8	-	5.5	V
		$V_{LCD} > 6.5$ V	2.5	-	5.5	V

Table 18. Static characteristics...continued

$V_{DD} = 1.8 \text{ V to } 5.5 \text{ V}$ ;  $V_{SS} = 0 \text{ V}$ ;  $V_{LCD} = 2.5 \text{ V to } 8.0 \text{ V}$ ;  $T_{amb} = -40 \text{ }^\circ\text{C to } +105 \text{ }^\circ\text{C}$ ; unless otherwise specified.

Symbol	Parameter	Conditions	Min	Typ	Max	Unit
$V_{LCD}$	LCD supply voltage	$V_{DD} < 2.5 \text{ V}$	2.5	-	6.5	V
		$V_{DD} \geq 2.5 \text{ V}$	2.5	-	8.0	V
$I_{DD}$	supply current	$f_{clk(ext)} = 1536 \text{ Hz}$	[1][2]	3.5	7	$\mu\text{A}$
		$V_{DD} = 3.0 \text{ V}$ ; $T_{amb} = 25 \text{ }^\circ\text{C}$	-	2.7	-	$\mu\text{A}$
$I_{DD(LCD)}$	LCD supply current	$f_{clk(ext)} = 1536 \text{ Hz}$	[1]	23	32	$\mu\text{A}$
		$V_{LCD} = 3.0 \text{ V}$ ; $T_{amb} = 25 \text{ }^\circ\text{C}$	-	13	-	$\mu\text{A}$
<b>Logic</b> <sup>[3]</sup>						
$V_{IL}$	LOW-level input voltage	on pins CLK, $\overline{\text{SYNC}}$ , OSC, A0, A1, T1, SA0, SCL, SDA	$V_{SS}$	-	$0.3V_{DD}$	V
$V_{IH}$	HIGH-level input voltage	on pins CLK, $\overline{\text{SYNC}}$ , OSC, A0, A1, T1, SA0, SCL, SDA	[4][5] $0.7V_{DD}$	-	$V_{DD}$	V
$I_{OL}$	LOW-level output current	output sink current; $V_{OL} = 0.4 \text{ V}$ ; $V_{DD} = 5 \text{ V}$				
		on pins CLK and $\overline{\text{SYNC}}$	1	-	-	mA
		on pin SDA	3	-	-	mA
$I_{OH(CLK)}$	HIGH-level output current on pin CLK	output source current; $V_{OH} = 4.6 \text{ V}$ ; $V_{DD} = 5 \text{ V}$	1	-	-	mA
$I_L$	leakage current	$V_I = V_{DD}$ or $V_{SS}$ ; on pins CLK, SCL, SDA, A0, A1, T1, and SA0	-1	-	+1	$\mu\text{A}$
$I_{L(OSC)}$	leakage current on pin OSC	$V_I = V_{DD}$	-1	-	+1	$\mu\text{A}$
$C_I$	input capacitance		[6]	-	7	pF
<b>LCD outputs</b>						
$\Delta V_O$	output voltage variation	on pins BP0 to BP3 and S0 to S31	-100	-	+100	mV
$R_O$	output resistance	$V_{LCD} = 5 \text{ V}$	[7]			
		on pins BP0 to BP3	-	1.5	-	k $\Omega$
		on pins S0 to S31	-	6.0	-	k $\Omega$

[1] LCD outputs are open-circuit; inputs at  $V_{SS}$  or  $V_{DD}$ ; external clock with 50 % duty factor; I<sup>2</sup>C-bus inactive.

[2] For typical values, see Figure 23.

[3] The I<sup>2</sup>C-bus interface of PCA85262 is 5 V tolerant.

[4] When tested, I<sup>2</sup>C pins SCL and SDA have no diode to  $V_{DD}$  and may be driven to the  $V_I$  limiting values given in Table 17 (see Figure 22 as well).

[5] Propagation delay of driver between clock (CLK) and LCD driving signals.

[6] Periodically sampled, not 100 % tested.

[7] Outputs measured one at a time.

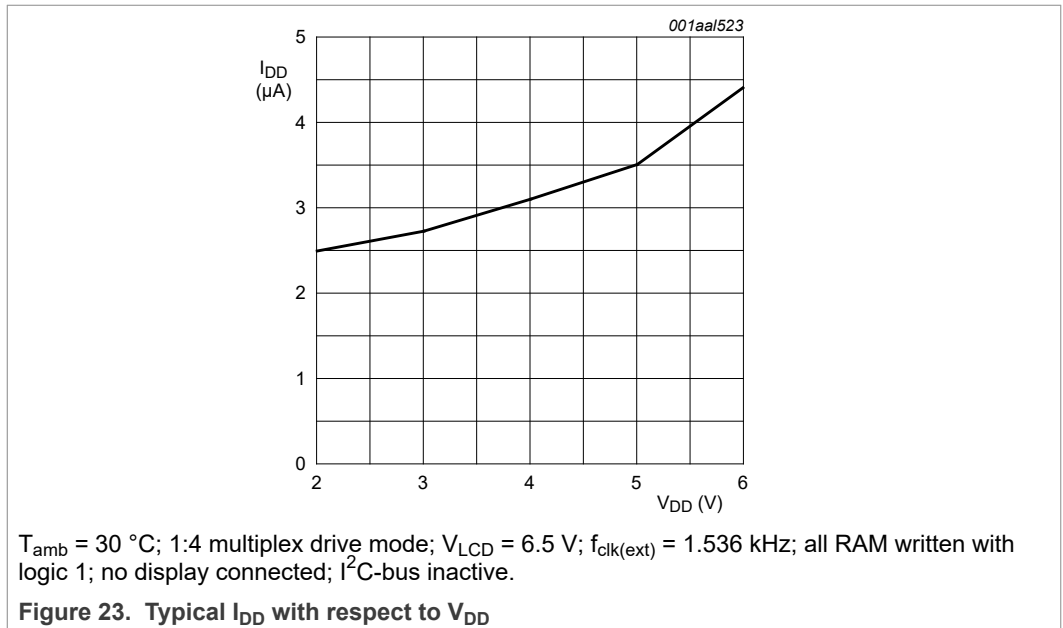

## 12 Dynamic characteristics

Table 19. Dynamic characteristics

V<sub>DD</sub> = 1.8 V to 5.5 V; V<sub>SS</sub> = 0 V; V<sub>LCD</sub> = 2.5 V to 8.0 V; T<sub>amb</sub> = -40 °C to +105 °C; unless otherwise specified.

Symbol	Parameter	Conditions	Min	Typ	Max	Unit
<b>Clock</b>						
f <sub>clk(int)</sub>	internal clock frequency		[1] 3 505	4 800	6 240	Hz
f <sub>clk(ext)</sub>	external clock frequency		960	-	6 720	Hz
f <sub>fr</sub>	frame frequency	internal clock	146	200	260	Hz
		external clock	40	-	280	Hz
t <sub>clk(H)</sub>	HIGH-level clock time		60	-	-	µs
t <sub>clk(L)</sub>	LOW-level clock time		60	-	-	µs
<b>Synchronization</b>						
t <sub>PD(SYNC_N)</sub>	SYNC <sub>N</sub> propagation delay		-	30	-	ns
t <sub>SYNC_NL</sub>	SYNC <sub>N</sub> LOW time		1	-	-	µs
t <sub>PD(drv)</sub>	driver propagation delay	V <sub>LCD</sub> = 5 V	[2] -	-	30	µs
<b>I<sup>2</sup>C-bus<sup>[3]</sup></b>						
<b>Pin SCL</b>						
f <sub>SCL</sub>	SCL clock frequency		-	-	400	kHz
t <sub>LOW</sub>	LOW period of the SCL clock		1.3	-	-	µs
t <sub>HIGH</sub>	HIGH period of the SCL clock		0.6	-	-	µs
<b>Pin SDA</b>						

Table 19. Dynamic characteristics...continued

$V_{DD} = 1.8\text{ V to }5.5\text{ V}$ ;  $V_{SS} = 0\text{ V}$ ;  $V_{LCD} = 2.5\text{ V to }8.0\text{ V}$ ;  $T_{amb} = -40\text{ }^{\circ}\text{C to }+105\text{ }^{\circ}\text{C}$ ; unless otherwise specified.

Symbol	Parameter	Conditions	Min	Typ	Max	Unit
$t_{SU,DAT}$	data set-up time		100	-	-	ns
$t_{HD,DAT}$	data hold time		0	-	-	ns
Pins SCL and SDA						
$t_{BUF}$	bus free time between a STOP and START condition		1.3	-	-	$\mu\text{s}$
$t_{SU,STO}$	set-up time for STOP condition		0.6	-	-	$\mu\text{s}$
$t_{HD,STA}$	hold time (repeated) START condition		0.6	-	-	$\mu\text{s}$
$t_{SU,STA}$	set-up time for a repeated START condition		0.6	-	-	$\mu\text{s}$
$t_r$	rise time of both SDA and SCL signals	$f_{SCL} = 400\text{ kHz}$	-	-	0.3	$\mu\text{s}$
		$f_{SCL} < 125\text{ kHz}$	-	-	1.0	$\mu\text{s}$
$t_f$	fall time of both SDA and SCL signals		-	-	0.3	$\mu\text{s}$
$C_b$	capacitive load for each bus line		-	-	400	pF
$t_{w(\text{spike})}$	spike pulse width	on the I <sup>2</sup> C-bus	-	-	50	ns

- [1] Typical output duty factor: 50 % measured at the CLK output pin.
- [2] Not tested in production.
- [3] All timing values are valid within the operating supply voltage and ambient temperature range and are referenced to  $V_{IL}$  and  $V_{IH}$  with an input voltage swing of  $V_{SS}$  to  $V_{DD}$ .

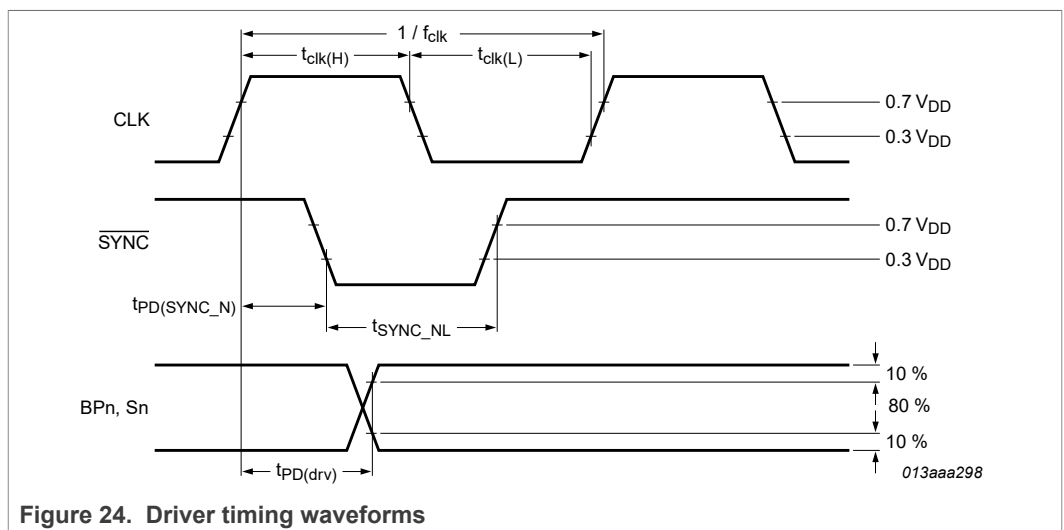
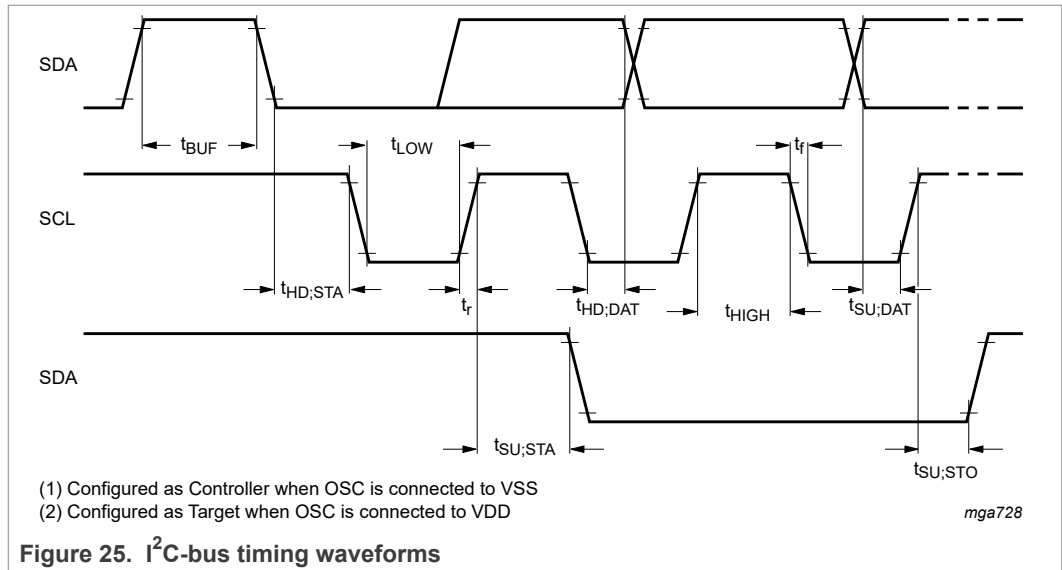

Figure 24. Driver timing waveforms



### 13 Application information

#### 13.1 Cascaded operation

Large display configurations of up to 8 PCA85262 can be recognized on the same I<sup>2</sup>C-bus by using the 2-bit hardware subaddress (A0 and A1) and the programmable I<sup>2</sup>C-bus target address (SA0).

Table 20. Addressing cascaded PCA85262

Cluster	Bit SA0	Pin A1	Pin A0	Device
1	0	0	0	0
		0	1	1
		1	0	2
		1	1	3
2	1	0	0	4
		0	1	5
		1	0	6
		1	1	7

When cascaded PCA85262 are synchronized, they can share the backplane signals from one of the devices in the cascade. Such an arrangement is cost-effective in large LCD applications since the backplane outputs of only one device need to be through-plated to the backplane electrodes of the display. The other PCA85262 of the cascade contribute additional segment outputs. The backplanes can either be connected together to enhance the drive capability or some can be left open-circuit (such as the ones from the target in [Figure 26](#)) or just some of the controller and some of the target can be taken to facilitate the layout of the display.

The SYNC line is provided to maintain the correct synchronization between all cascaded PCA85262. Synchronization is guaranteed after a power-on and initialization. The only

time that  $\overline{\text{SYNC}}$  is likely to be needed is if synchronization is accidentally lost (e.g. by noise in adverse electrical environments or by defining a multiplex drive mode when PCA85262 with different SA0 levels are cascaded).

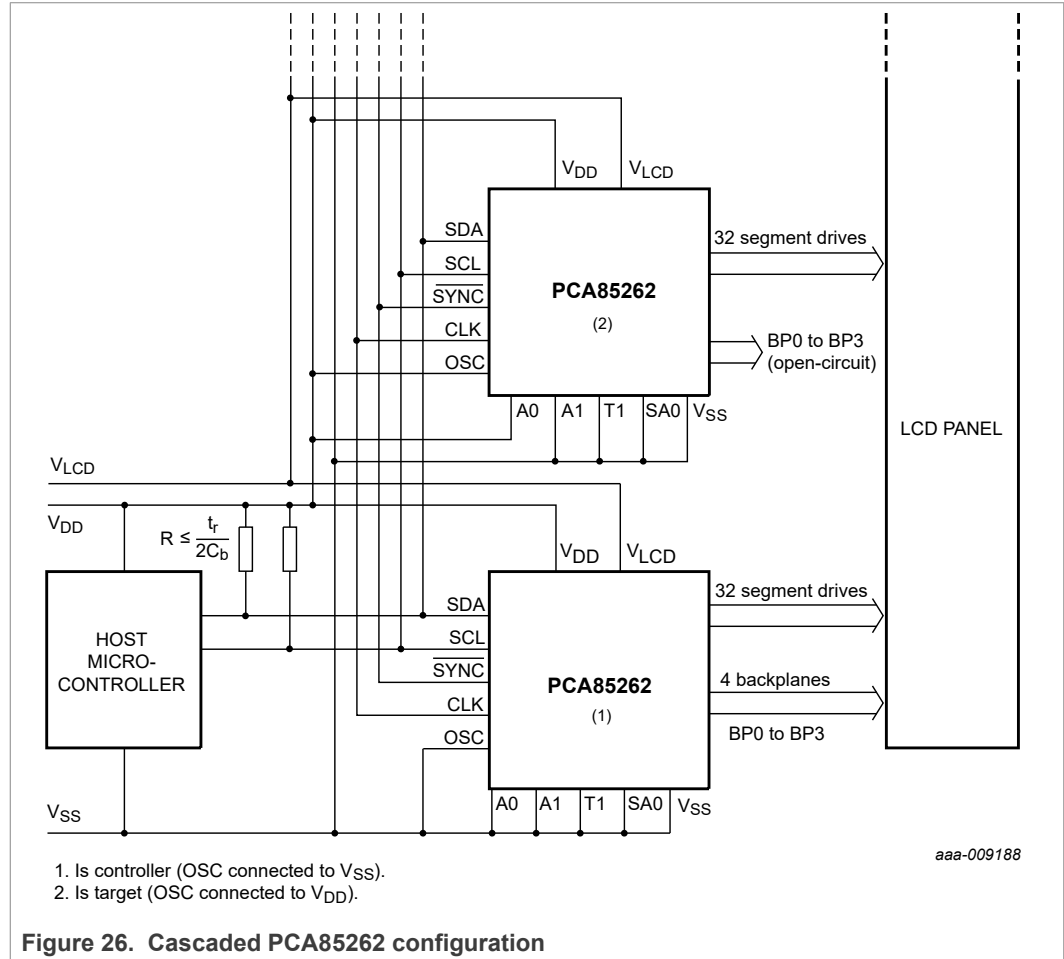

Figure 26. Cascaded PCA85262 configuration

$\overline{\text{SYNC}}$  is organized as an input/output pin. The output selection is realized as an open-drain driver with an internal pull-up resistor. A PCA85262 asserts the  $\overline{\text{SYNC}}$  line at the onset of its last active backplane signal and monitors the  $\overline{\text{SYNC}}$  line at all other times. If synchronization in the cascade is lost, it is restored by the first PCA85262 to assert  $\overline{\text{SYNC}}$ . The timing relationship between the backplane waveforms and the  $\overline{\text{SYNC}}$  signal for the various drive modes of the PCA85262 are shown in [Figure 27](#).

The PCA85262 can always be cascaded with other devices of the same type or conditionally with other devices of the same family. This allows optimal drive selection for a given number of pixels to display. [Figure 27](#) shows the timing of the synchronization signals.

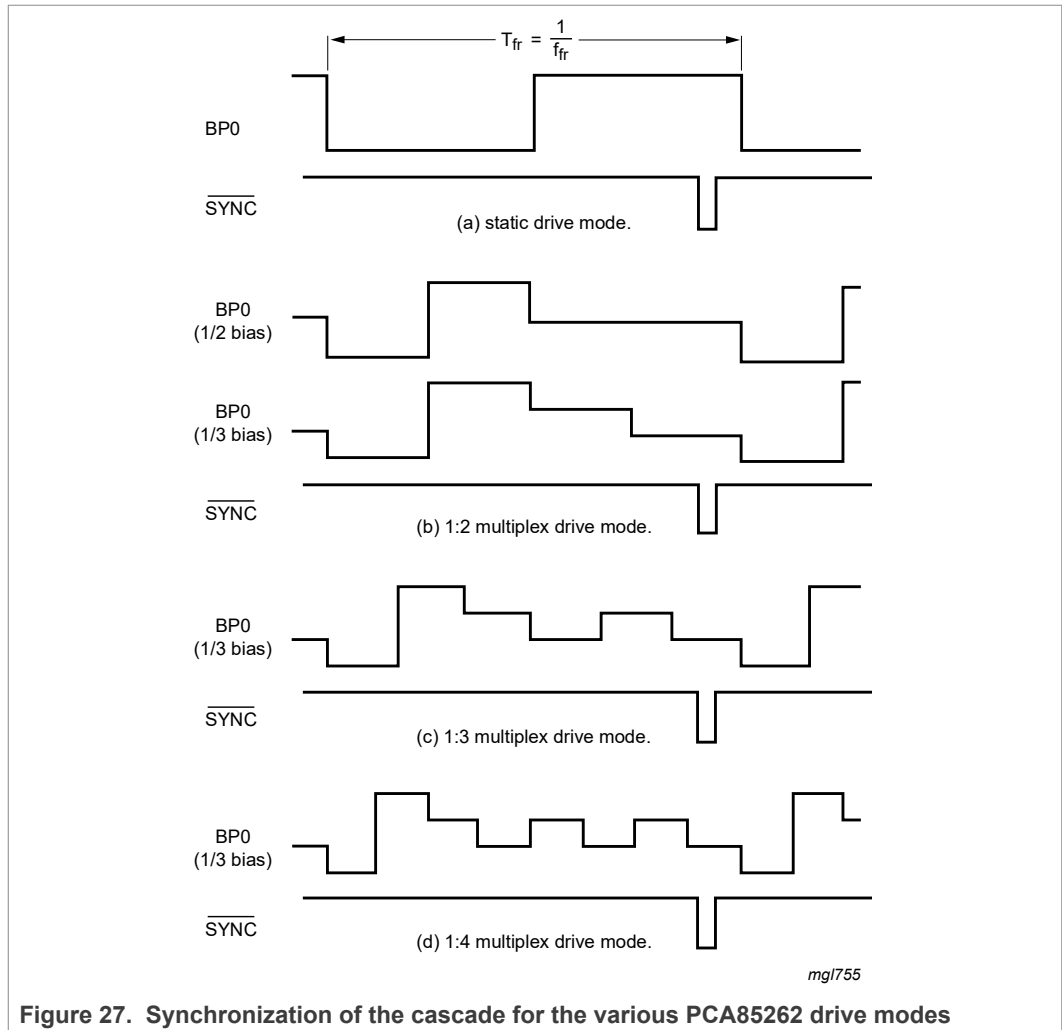

Figure 27. Synchronization of the cascade for the various PCA85262 drive modes

Only one controller but multiple targets are allowed in a cascade. All devices in the cascade have to use the same clock whether it is supplied externally or provided by the controller.

If an external clock source is used, all PCA85262 in the cascade must be configured such as to receive the clock from that external source (pin OSC connected to  $V_{DD}$ ). Thereby it must be ensured that the clock tree is designed such that on all PCA85262 the clock propagation delay from the clock source to all PCA85262 in the cascade is as equal as possible since otherwise synchronization artifacts may occur.

In mixed cascading configurations, care has to be taken that the specifications of the individual cascaded devices are always met.

## 14 Test information

### 14.1 Quality information

This product has been qualified in accordance with the Automotive Electronics Council (AEC) standard Q100 - *Failure mechanism based stress test qualification for integrated circuits*, and is suitable for use in automotive applications.

15 Package outline

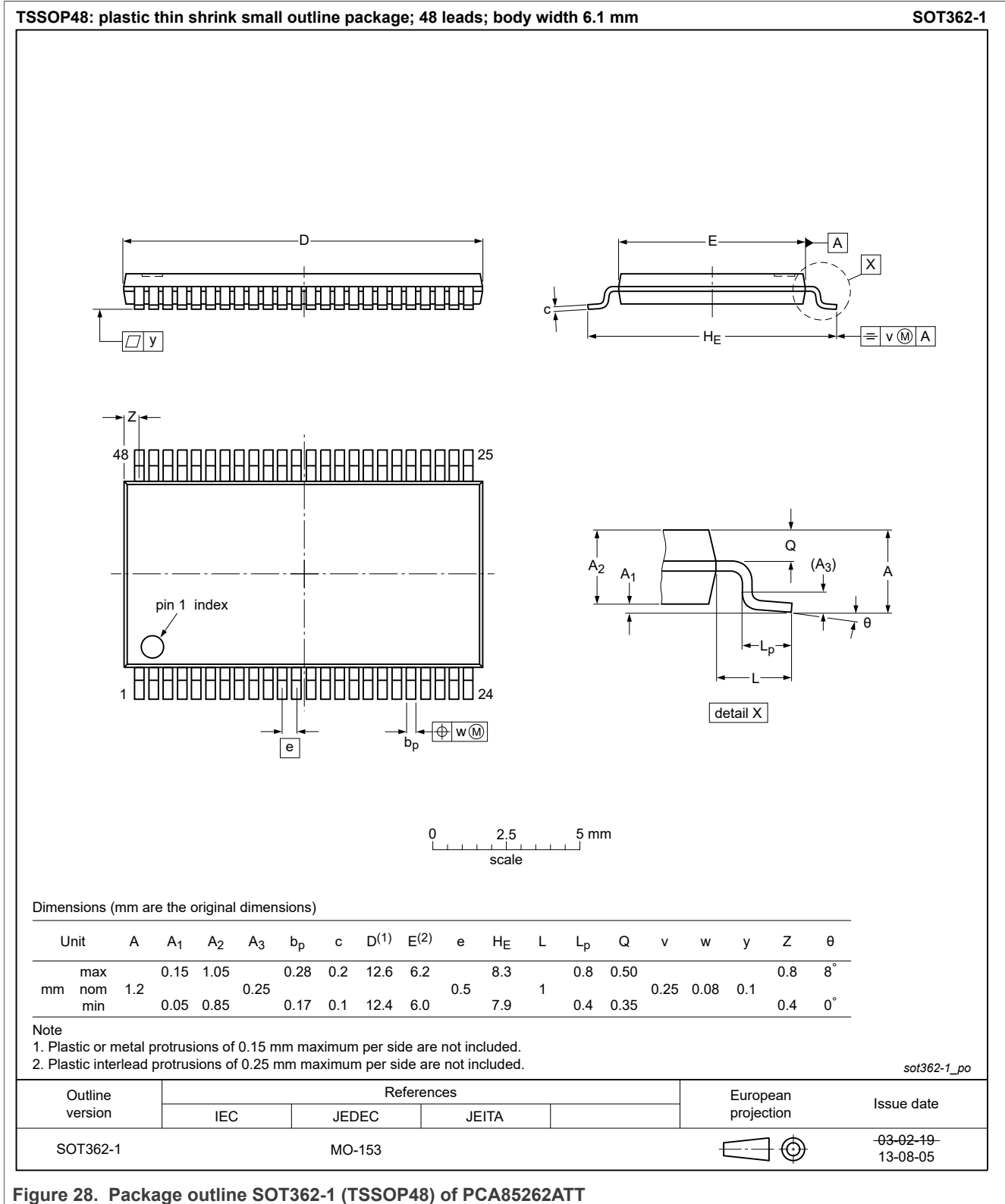

Figure 28. Package outline SOT362-1 (TSSOP48) of PCA85262ATT

## 16 Handling information

---

All input and output pins are protected against ElectroStatic Discharge (ESD) under normal handling. When handling Metal-Oxide Semiconductor (MOS) devices ensure that all normal precautions are taken as described in *JESD625-A*, *IEC 61340-5* or equivalent standards.

## 17 Packing information

---

### 17.1 Tape and reel information

For tape and reel packing information, please see [\[4\]](#).

## 18 Soldering of SMD packages

---

This text provides a very brief insight into a complex technology. A more in-depth account of soldering ICs can be found in Application Note *AN10365 "Surface mount reflow soldering description"*.

### 18.1 Introduction to soldering

Soldering is one of the most common methods through which packages are attached to Printed Circuit Boards (PCBs), to form electrical circuits. The soldered joint provides both the mechanical and the electrical connection. There is no single soldering method that is ideal for all IC packages. Wave soldering is often preferred when through-hole and Surface Mount Devices (SMDs) are mixed on one printed wiring board; however, it is not suitable for fine pitch SMDs. Reflow soldering is ideal for the small pitches and high densities that come with increased miniaturization.

### 18.2 Wave and reflow soldering

Wave soldering is a joining technology in which the joints are made by solder coming from a standing wave of liquid solder. The wave soldering process is suitable for the following:

- Through-hole components
- Leaded or leadless SMDs, which are glued to the surface of the printed circuit board

Not all SMDs can be wave soldered. Packages with solder balls, and some leadless packages which have solder lands underneath the body, cannot be wave soldered. Also, leaded SMDs with leads having a pitch smaller than ~0.6 mm cannot be wave soldered, due to an increased probability of bridging.

The reflow soldering process involves applying solder paste to a board, followed by component placement and exposure to a temperature profile. Leaded packages, packages with solder balls, and leadless packages are all reflow solderable.

Key characteristics in both wave and reflow soldering are:

- Board specifications, including the board finish, solder masks and vias
- Package footprints, including solder thieves and orientation
- The moisture sensitivity level of the packages

- Package placement
- Inspection and repair
- Lead-free soldering versus SnPb soldering

### 18.3 Wave soldering

Key characteristics in wave soldering are:

- Process issues, such as application of adhesive and flux, clinching of leads, board transport, the solder wave parameters, and the time during which components are exposed to the wave
- Solder bath specifications, including temperature and impurities

### 18.4 Reflow soldering

Key characteristics in reflow soldering are:

- Lead-free versus SnPb soldering; note that a lead-free reflow process usually leads to higher minimum peak temperatures (see [Figure 29](#)) than a SnPb process, thus reducing the process window
- Solder paste printing issues including smearing, release, and adjusting the process window for a mix of large and small components on one board
- Reflow temperature profile; this profile includes preheat, reflow (in which the board is heated to the peak temperature) and cooling down. It is imperative that the peak temperature is high enough for the solder to make reliable solder joints (a solder paste characteristic). In addition, the peak temperature must be low enough that the packages and/or boards are not damaged. The peak temperature of the package depends on package thickness and volume and is classified in accordance with [Table 21](#) and [Table 22](#)

Table 21. SnPb eutectic process (from J-STD-020D)

Package thickness (mm)	Package reflow temperature (°C)	
	Volume (mm <sup>3</sup> )	
	< 350	≥ 350
< 2.5	235	220
≥ 2.5	220	220

Table 22. Lead-free process (from J-STD-020D)

Package thickness (mm)	Package reflow temperature (°C)		
	Volume (mm <sup>3</sup> )		
	< 350	350 to 2000	> 2000
< 1.6	260	260	260
1.6 to 2.5	260	250	245
> 2.5	250	245	245

Moisture sensitivity precautions, as indicated on the packing, must be respected at all times.

Studies have shown that small packages reach higher temperatures during reflow soldering, see [Figure 29](#).

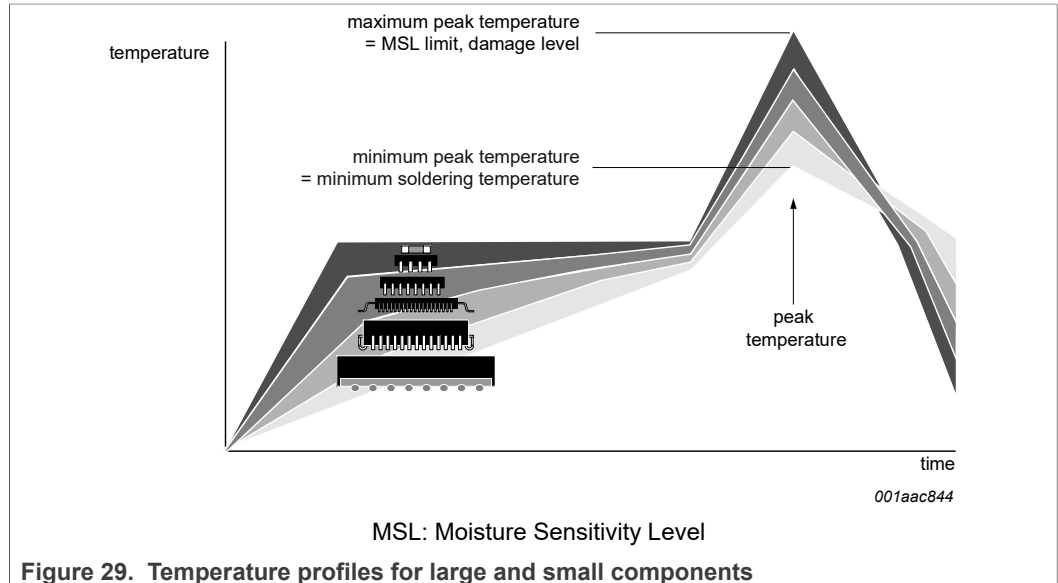

For further information on temperature profiles, refer to Application Note *AN10365* “*Surface mount reflow soldering description*”.

19 Footprint information

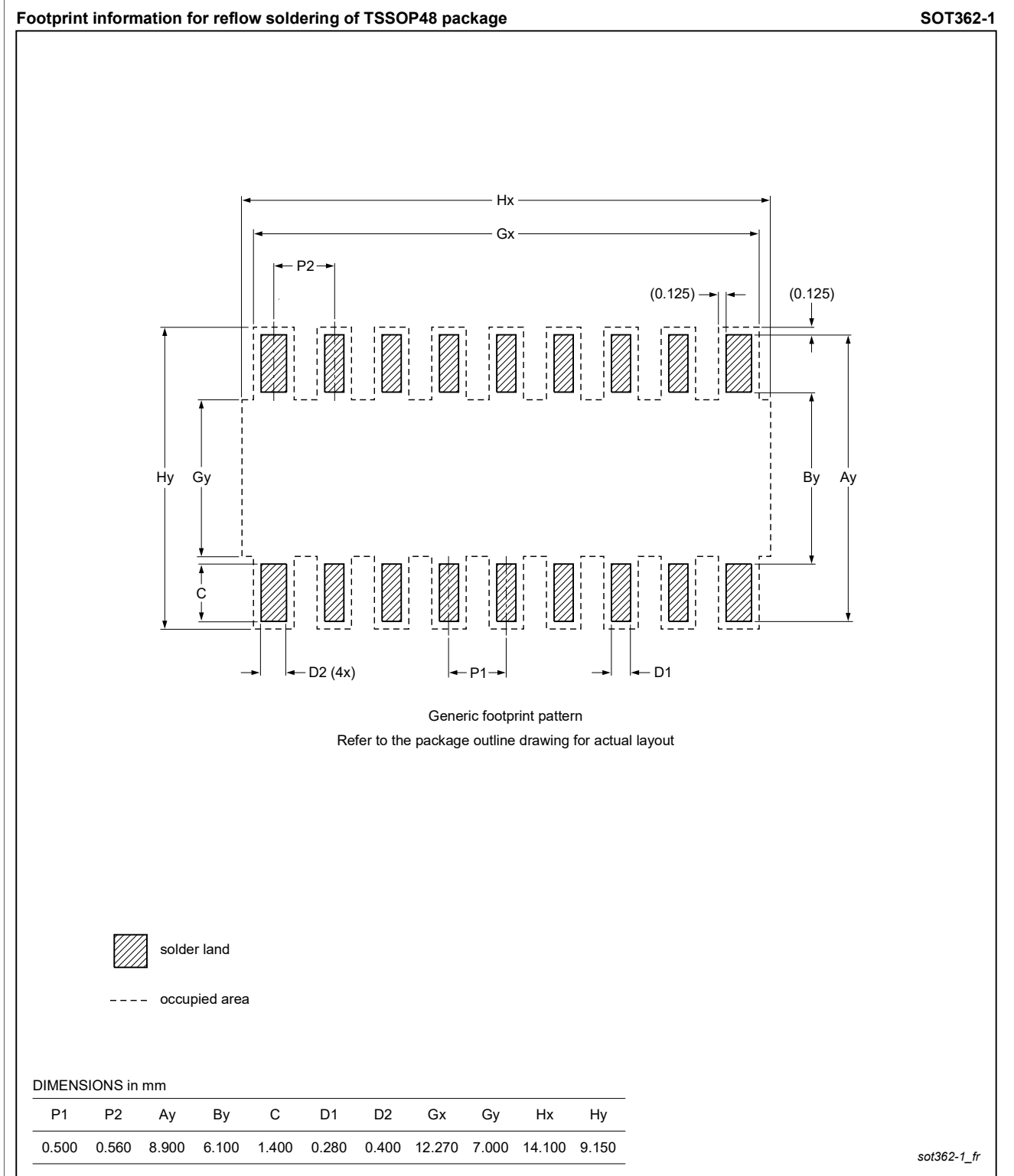

Figure 30. Footprint information for reflow soldering of SOT362-1 (TSSOP48) of PCA85262ATT

## 20 Appendix

---

### 20.1 LCD segment driver selection

Table 23. Selection of LCD segment drivers

Type name	Number of elements at MUX							V <sub>DD</sub> (V)	V <sub>LCD</sub> (V)	f <sub>fr</sub> (Hz)	V <sub>LCD</sub> (V) charge pump	V <sub>LCD</sub> (V) temperature compensat.	T <sub>amb</sub> (°C)	Interface	Package	AEC- Q100
	1:1	1:2	1:3	1:4	1:6	1:8	1:9									
PCA8553DTT	40	80	120	160	-	-	-	1.8 to 5.5	1.8 to 5.5	32 to 256 <sup>[1]</sup>	N	N	-40 to 105	I <sup>2</sup> C / SPI	TSSOP56	Y
PCA8546ATT	-	-	-	176	-	-	-	1.8 to 5.5	2.5 to 9	60 to 300 <sup>[1]</sup>	N	N	-40 to 95	I <sup>2</sup> C	TSSOP56	Y
PCA8546BTT	-	-	-	176	-	-	-	1.8 to 5.5	2.5 to 9	60 to 300 <sup>[1]</sup>	N	N	-40 to 95	SPI	TSSOP56	Y
PCA8547AHT	44	88	-	176	-	-	-	1.8 to 5.5	2.5 to 9	60 to 300 <sup>[1]</sup>	Y	Y	-40 to 95	I <sup>2</sup> C	TQFP64	Y
PCA8547BHT	44	88	-	176	-	-	-	1.8 to 5.5	2.5 to 9	60 to 300 <sup>[1]</sup>	Y	Y	-40 to 95	SPI	TQFP64	Y
PCF85134HL	60	120	180	240	-	-	-	1.8 to 5.5	2.5 to 6.5	82	N	N	-40 to 85	I <sup>2</sup> C	LQFP80	N
PCA85134H	60	120	180	240	-	-	-	1.8 to 5.5	2.5 to 8	82	N	N	-40 to 95	I <sup>2</sup> C	LQFP80	Y
PCA8543AHL	60	120	-	240	-	-	-	2.5 to 5.5	2.5 to 9	60 to 300 <sup>[1]</sup>	Y	Y	-40 to 105	I <sup>2</sup> C	LQFP80	Y
PCF8545ATT	-	-	-	176	252	320	-	1.8 to 5.5	2.5 to 5.5	60 to 300 <sup>[1]</sup>	N	N	-40 to 85	I <sup>2</sup> C	TSSOP56	N
PCF8545BTT	-	-	-	176	252	320	-	1.8 to 5.5	2.5 to 5.5	60 to 300 <sup>[1]</sup>	N	N	-40 to 85	SPI	TSSOP56	N
PCF8536AT	-	-	-	176	252	320	-	1.8 to 5.5	2.5 to 9	60 to 300 <sup>[1]</sup>	N	N	-40 to 85	I <sup>2</sup> C	TSSOP56	N
PCF8536BT	-	-	-	176	252	320	-	1.8 to 5.5	2.5 to 9	60 to 300 <sup>[1]</sup>	N	N	-40 to 85	SPI	TSSOP56	N
PCA8536AT	-	-	-	176	252	320	-	1.8 to 5.5	2.5 to 9	60 to 300 <sup>[1]</sup>	N	N	-40 to 95	I <sup>2</sup> C	TSSOP56	Y
PCA8536BT	-	-	-	176	252	320	-	1.8 to 5.5	2.5 to 9	60 to 300 <sup>[1]</sup>	N	N	-40 to 95	SPI	TSSOP56	Y
PCF8537AH	44	88	-	176	276	352	-	1.8 to 5.5	2.5 to 9	60 to 300 <sup>[1]</sup>	Y	Y	-40 to 85	I <sup>2</sup> C	TQFP64	N
PCF8537BH	44	88	-	176	276	352	-	1.8 to 5.5	2.5 to 9	60 to 300 <sup>[1]</sup>	Y	Y	-40 to 85	SPI	TQFP64	N
PCA8537AH	44	88	-	176	276	352	-	1.8 to 5.5	2.5 to 9	60 to 300 <sup>[1]</sup>	Y	Y	-40 to 95	I <sup>2</sup> C	TQFP64	Y
PCA8537BH	44	88	-	176	276	352	-	1.8 to 5.5	2.5 to 9	60 to 300 <sup>[1]</sup>	Y	Y	-40 to 95	SPI	TQFP64	Y
PCA9620H	60	120	-	240	320	480	-	2.5 to 5.5	2.5 to 9	60 to 300 <sup>[1]</sup>	Y	Y	-40 to 105	I <sup>2</sup> C	LQFP80	Y
PCA9620U	60	120	-	240	320	480	-	2.5 to 5.5	2.5 to 9	60 to 300 <sup>[1]</sup>	Y	Y	-40 to 105	I <sup>2</sup> C	Bare die	Y
PCF8576DU	40	80	120	160	-	-	-	1.8 to 5.5	2.5 to 6.5	77	N	N	-40 to 85	I <sup>2</sup> C	Bare die	N
PCF8576EUG	40	80	120	160	-	-	-	1.8 to 5.5	2.5 to 6.5	77	N	N	-40 to 85	I <sup>2</sup> C	Bare die	N
PCA8576FUG	40	80	120	160	-	-	-	1.8 to 5.5	2.5 to 8	200	N	N	-40 to 105	I <sup>2</sup> C	Bare die	Y
PCF85133U	80	160	240	320	-	-	-	1.8 to 5.5	2.5 to 6.5	82, 110 <sup>[2]</sup>	N	N	-40 to 85	I <sup>2</sup> C	Bare die	N

Table 23. Selection of LCD segment drivers...continued

Type name	Number of elements at MUX							V <sub>DD</sub> (V)	V <sub>LCD</sub> (V)	f <sub>fr</sub> (Hz)	V <sub>LCD</sub> (V) charge pump	V <sub>LCD</sub> (V) temperature compensat.	T <sub>amb</sub> (°C)	Interface	Package	AEC- Q100
	1:1	1:2	1:3	1:4	1:6	1:8	1:9									
PCA85133U	80	160	240	320	-	-	-	1.8 to 5.5	2.5 to 8	82, 110 <sup>[2]</sup>	N	N	-40 to 95	I <sup>2</sup> C	Bare die	Y
PCA85233UG	80	160	240	320	-	-	-	1.8 to 5.5	2.5 to 8	150, 220 <sup>[2]</sup>	N	N	-40 to 105	I <sup>2</sup> C	Bare die	Y
PCF85132U	160	320	480	640	-	-	-	1.8 to 5.5	1.8 to 8	60 to 90 <sup>[1]</sup>	N	N	-40 to 85	I <sup>2</sup> C	Bare die	N
PCA8530DUG	102	204	-	408	-	-	-	2.5 to 5.5	4 to 12	45 to 300 <sup>[1]</sup>	Y	Y	-40 to 105	I <sup>2</sup> C / SPI	Bare die	Y
PCA85132U	160	320	480	640	-	-	-	1.8 to 5.5	1.8 to 8	60 to 90 <sup>[1]</sup>	N	N	-40 to 95	I <sup>2</sup> C	Bare die	Y
PCA85232U	160	320	480	640	-	-	-	1.8 to 5.5	1.8 to 8	117 to 176 <sup>[1]</sup>	N	N	-40 to 95	I <sup>2</sup> C	Bare die	Y
PCF8538UG	102	204	-	408	612	816	918	2.5 to 5.5	4 to 12	45 to 300 <sup>[1]</sup>	Y	Y	-40 to 85	I <sup>2</sup> C / SPI	Bare die	N
PCA8538UG	102	204	-	408	612	816	918	2.5 to 5.5	4 to 12	45 to 300 <sup>[1]</sup>	Y	Y	-40 to 105	I <sup>2</sup> C / SPI	Bare die	Y

[1] Software programmable.

[2] Hardware selectable.

## 21 Abbreviations

Table 24. Abbreviations

Acronym	Description
AEC	Automotive Electronics Council
CMOS	Complementary Metal-Oxide Semiconductor
CDM	Charged Device Model
DC	Direct Current
HBM	Human Body Model
I <sup>2</sup> C	Inter-Integrated Circuit
IC	Integrated Circuit
LCD	Liquid Crystal Display
LSB	Least Significant Bit
MSB	Most Significant Bit
MSL	Moisture Sensitivity Level
PCB	Printed-Circuit Board
RAM	Random Access Memory
RC	Resistance and Capacitance
RMS	Root Mean Square
SCL	Serial CLock line
SDA	Serial DATa Line
SMD	Surface-Mount Device

## 22 References

- [1] JESD22-A114 Electrostatic Discharge (ESD) Sensitivity Testing Human Body Model (HBM)
- [2] JESD22-C101 Field-Induced Charged-Device Model Test Method for Electrostatic-Discharge-Withstand Thresholds of Microelectronic Components
- [3] JESD78 IC Latch-Up Test
- [4] SOT362-1\_118 TSSOP48; Reel pack; SMD, 13", Packing information
- [5] UM10569 Store and transport requirements

## 23 Revision history

Table 25. Revision history

Document ID	Release date	Data sheet status	Change notice	Supersedes
PCA85262 v.4	20210930	Product data sheet	PCN202102010F01	PCA85262 v.3
Modifications	<ul style="list-style-type: none"> <li>Updated <a href="#">Ordering information</a>. See Change notice column.</li> <li>Global: The terms "master" and "slave" changed to "controller" and "target" to comply with NXP inclusive language policy.</li> </ul>			
PCA85262 v.3	20181112	Product data sheet	201810014I	PCA85262 v.2
Modifications:	<ul style="list-style-type: none"> <li>Updated <a href="#">Section 6.4</a></li> <li>Updated layout of <a href="#">Section 3</a></li> </ul>			
PCA85262 v.2	20150410	Product data sheet	-	PCA85262 v.1
Modifications:	<ul style="list-style-type: none"> <li>The format of this data sheet has been redesigned to comply with the new identity guidelines of NXP Semiconductors.</li> <li>Legal texts have been adapted to the new company name where appropriate.</li> <li>Changed pin configuration due to redesign</li> <li>Enhanced <math>\overline{\text{SYNC}}</math> pin description in <a href="#">Table 3</a></li> <li>Changed typical value of <math>I_{DD}</math> and <math>I_{DD(LCD)}</math> in <a href="#">Table 18</a></li> <li>Adjusted description of initialization (<a href="#">Section 6.4</a>)</li> </ul>			
PCA85262 v.1	20140211	Product data sheet	-	-

## 24 Legal information

### 24.1 Data sheet status

Document status <sup>[1][2]</sup>	Product status <sup>[3]</sup>	Definition
Objective [short] data sheet	Development	This document contains data from the objective specification for product development.
Preliminary [short] data sheet	Qualification	This document contains data from the preliminary specification.
Product [short] data sheet	Production	This document contains the product specification.

[1] Please consult the most recently issued document before initiating or completing a design.

[2] The term 'short data sheet' is explained in section "Definitions".

[3] The product status of device(s) described in this document may have changed since this document was published and may differ in case of multiple devices. The latest product status information is available on the Internet at URL <http://www.nxp.com>.

### 24.2 Definitions

**Draft** — A draft status on a document indicates that the content is still under internal review and subject to formal approval, which may result in modifications or additions. NXP Semiconductors does not give any representations or warranties as to the accuracy or completeness of information included in a draft version of a document and shall have no liability for the consequences of use of such information.

**Short data sheet** — A short data sheet is an extract from a full data sheet with the same product type number(s) and title. A short data sheet is intended for quick reference only and should not be relied upon to contain detailed and full information. For detailed and full information see the relevant full data sheet, which is available on request via the local NXP Semiconductors sales office. In case of any inconsistency or conflict with the short data sheet, the full data sheet shall prevail.

**Product specification** — The information and data provided in a Product data sheet shall define the specification of the product as agreed between NXP Semiconductors and its customer, unless NXP Semiconductors and customer have explicitly agreed otherwise in writing. In no event however, shall an agreement be valid in which the NXP Semiconductors product is deemed to offer functions and qualities beyond those described in the Product data sheet.

### 24.3 Disclaimers

**Limited warranty and liability** — Information in this document is believed to be accurate and reliable. However, NXP Semiconductors does not give any representations or warranties, expressed or implied, as to the accuracy or completeness of such information and shall have no liability for the consequences of use of such information. NXP Semiconductors takes no responsibility for the content in this document if provided by an information source outside of NXP Semiconductors. In no event shall NXP Semiconductors be liable for any indirect, incidental, punitive, special or consequential damages (including - without limitation - lost profits, lost savings, business interruption, costs related to the removal or replacement of any products or rework charges) whether or not such damages are based on tort (including negligence), warranty, breach of contract or any other legal theory. Notwithstanding any damages that customer might incur for any reason whatsoever, NXP Semiconductors' aggregate and cumulative liability towards customer for the products described herein shall be limited in accordance with the Terms and conditions of commercial sale of NXP Semiconductors.

**Right to make changes** — NXP Semiconductors reserves the right to make changes to information published in this document, including without limitation specifications and product descriptions, at any time and without

notice. This document supersedes and replaces all information supplied prior to the publication hereof.

**Applications** — Applications that are described herein for any of these products are for illustrative purposes only. NXP Semiconductors makes no representation or warranty that such applications will be suitable for the specified use without further testing or modification. Customers are responsible for the design and operation of their applications and products using NXP Semiconductors products, and NXP Semiconductors accepts no liability for any assistance with applications or customer product design. It is customer's sole responsibility to determine whether the NXP Semiconductors product is suitable and fit for the customer's applications and products planned, as well as for the planned application and use of customer's third party customer(s). Customers should provide appropriate design and operating safeguards to minimize the risks associated with their applications and products. NXP Semiconductors does not accept any liability related to any default, damage, costs or problem which is based on any weakness or default in the customer's applications or products, or the application or use by customer's third party customer(s). Customer is responsible for doing all necessary testing for the customer's applications and products using NXP Semiconductors products in order to avoid a default of the applications and the products or of the application or use by customer's third party customer(s). NXP does not accept any liability in this respect.

**Limiting values** — Stress above one or more limiting values (as defined in the Absolute Maximum Ratings System of IEC 60134) will cause permanent damage to the device. Limiting values are stress ratings only and (proper) operation of the device at these or any other conditions above those given in the Recommended operating conditions section (if present) or the Characteristics sections of this document is not warranted. Constant or repeated exposure to limiting values will permanently and irreversibly affect the quality and reliability of the device.

**Terms and conditions of commercial sale** — NXP Semiconductors products are sold subject to the general terms and conditions of commercial sale, as published at <http://www.nxp.com/profile/terms>, unless otherwise agreed in a valid written individual agreement. In case an individual agreement is concluded only the terms and conditions of the respective agreement shall apply. NXP Semiconductors hereby expressly objects to applying the customer's general terms and conditions with regard to the purchase of NXP Semiconductors products by customer.

**No offer to sell or license** — Nothing in this document may be interpreted or construed as an offer to sell products that is open for acceptance or the grant, conveyance or implication of any license under any copyrights, patents or other industrial or intellectual property rights.

**Suitability for use in automotive applications** — This NXP product has been qualified for use in automotive applications. If this product is used by customer in the development of, or for incorporation into, products or services (a) used in safety critical applications or (b) in which failure could lead to death, personal injury, or severe physical or environmental damage (such products and services hereinafter referred to as "Critical Applications"),

then customer makes the ultimate design decisions regarding its products and is solely responsible for compliance with all legal, regulatory, safety, and security related requirements concerning its products, regardless of any information or support that may be provided by NXP. As such, customer assumes all risk related to use of any products in Critical Applications and NXP and its suppliers shall not be liable for any such use by customer. Accordingly, customer will indemnify and hold NXP harmless from any claims, liabilities, damages and associated costs and expenses (including attorneys' fees) that NXP may incur related to customer's incorporation of any product in a Critical Application.

**Export control** — This document as well as the item(s) described herein may be subject to export control regulations. Export might require a prior authorization from competent authorities.

**Translations** — A non-English (translated) version of a document is for reference only. The English version shall prevail in case of any discrepancy between the translated and English versions.

## 24.4 Trademarks

Notice: All referenced brands, product names, service names and trademarks are the property of their respective owners.

**I<sup>2</sup>C-bus** — logo is a trademark of NXP B.V.

**NXP** — wordmark and logo are trademarks of NXP B.V.

## Tables

Tab. 1.	Ordering information .....	2	Tab. 13.	Entire RAM filling by rewriting in 1:3 multiplex drive mode .....	13
Tab. 2.	Ordering options .....	2	Tab. 14.	Selection of possible display configurations ....	17
Tab. 3.	Pin description of PCA85262ATT (TSSOP48) .....	4	Tab. 15.	Biasing characteristics .....	18
Tab. 4.	Definition of the PCA85262 commands .....	5	Tab. 16.	I2C target address byte .....	27
Tab. 5.	C bit description .....	5	Tab. 17.	Limiting values .....	30
Tab. 6.	Mode-set command bit description .....	6	Tab. 18.	Static characteristics .....	30
Tab. 7.	Load-data-pointer command bit description .....	6	Tab. 19.	Dynamic characteristics .....	32
Tab. 8.	Device-select command bit description .....	7	Tab. 20.	Addressing cascaded PCA85262 .....	34
Tab. 9.	Bank-select command bit description .....	7	Tab. 21.	SnPb eutectic process (from J-STD-020D) .....	39
Tab. 10.	Blink-select command bit description .....	7	Tab. 22.	Lead-free process (from J-STD-020D) .....	39
Tab. 11.	Blink frequencies .....	8	Tab. 23.	Selection of LCD segment drivers .....	43
Tab. 12.	Standard RAM filling in 1:3 multiplex drive mode .....	13	Tab. 24.	Abbreviations .....	45
			Tab. 25.	Revision history .....	46

## Figures

Fig. 1.	Block diagram of PCA85262 .....	3	Fig. 15.	Waveforms for the 1:4 multiplex drive mode with 1/3 bias .....	24
Fig. 2.	Pinning diagram for PCA85262ATT (TSSOP48) .....	4	Fig. 16.	Bit transfer .....	25
Fig. 3.	Display RAM bitmap .....	9	Fig. 17.	Definition of START and STOP conditions .....	26
Fig. 4.	Relationship between LCD layout, drive mode, display RAM filling order, and display data transmitted over the I2C-bus .....	11	Fig. 18.	System configuration .....	26
Fig. 5.	RAM banks in static and multiplex driving mode 1:2 .....	14	Fig. 19.	Acknowledgement of the I2C-bus .....	27
Fig. 6.	Bank selection .....	15	Fig. 20.	I2C-bus protocol .....	28
Fig. 7.	Example of the Bank-select command with multiplex drive mode 1:2 .....	15	Fig. 21.	Format of command byte .....	28
Fig. 8.	Example of displays suitable for PCA85262 .....	16	Fig. 22.	Device protection circuits .....	29
Fig. 9.	Typical system configuration .....	17	Fig. 23.	Typical IDD with respect to VDD .....	32
Fig. 10.	Electro-optical characteristic: relative transmission curve of the liquid .....	19	Fig. 24.	Driver timing waveforms .....	33
Fig. 11.	Static drive mode waveforms .....	20	Fig. 25.	I2C-bus timing waveforms .....	34
Fig. 12.	Waveforms for the 1:2 multiplex drive mode with 1/2 bias .....	21	Fig. 26.	Cascaded PCA85262 configuration .....	35
Fig. 13.	Waveforms for the 1:2 multiplex drive mode with 1/3 bias .....	22	Fig. 27.	Synchronization of the cascade for the various PCA85262 drive modes .....	36
Fig. 14.	Waveforms for the 1:3 multiplex drive mode with 1/3 bias .....	23	Fig. 28.	Package outline SOT362-1 (TSSOP48) of PCA85262ATT .....	37
			Fig. 29.	Temperature profiles for large and small components .....	40
			Fig. 30.	Footprint information for reflow soldering of SOT362-1 (TSSOP48) of PCA85262ATT .....	41

## Contents

<b>1</b>	<b>General description</b> .....	<b>1</b>	<b>9</b>	<b>Safety notes</b> .....	<b>29</b>
<b>2</b>	<b>Features and benefits</b> .....	<b>1</b>	<b>10</b>	<b>Limiting values</b> .....	<b>30</b>
<b>3</b>	<b>Ordering information</b> .....	<b>2</b>	<b>11</b>	<b>Static characteristics</b> .....	<b>30</b>
3.1	Ordering options .....	2	<b>12</b>	<b>Dynamic characteristics</b> .....	<b>32</b>
<b>4</b>	<b>Block diagram</b> .....	<b>3</b>	<b>13</b>	<b>Application information</b> .....	<b>34</b>
<b>5</b>	<b>Pinning information</b> .....	<b>3</b>	13.1	Cascaded operation .....	34
5.1	Pinning .....	4	<b>14</b>	<b>Test information</b> .....	<b>36</b>
5.2	Pin description .....	4	14.1	Quality information .....	36
<b>6</b>	<b>Functional description</b> .....	<b>5</b>	<b>15</b>	<b>Package outline</b> .....	<b>37</b>
6.1	Commands of PCA85262 .....	5	<b>16</b>	<b>Handling information</b> .....	<b>38</b>
6.1.1	Command: mode-set .....	6	<b>17</b>	<b>Packing information</b> .....	<b>38</b>
6.1.2	Command: load-data-pointer .....	6	17.1	Tape and reel information .....	38
6.1.3	Command: device-select .....	6	<b>18</b>	<b>Soldering of SMD packages</b> .....	<b>38</b>
6.1.4	Command: bank-select .....	7	18.1	Introduction to soldering .....	38
6.1.5	Command: blink-select .....	7	18.2	Wave and reflow soldering .....	38
6.1.5.1	Blinking .....	8	18.3	Wave soldering .....	39
6.2	Clock and frame frequency .....	8	18.4	Reflow soldering .....	39
6.2.1	Internal clock .....	8	<b>19</b>	<b>Footprint information</b> .....	<b>41</b>
6.2.2	External clock .....	9	<b>20</b>	<b>Appendix</b> .....	<b>42</b>
6.2.3	Timing .....	9	20.1	LCD segment driver selection .....	42
6.3	Display RAM .....	9	<b>21</b>	<b>Abbreviations</b> .....	<b>45</b>
6.3.1	Data pointer .....	12	<b>22</b>	<b>References</b> .....	<b>45</b>
6.3.2	Subaddress counter .....	12	<b>23</b>	<b>Revision history</b> .....	<b>46</b>
6.3.3	RAM addressing in cascaded applications .....	12	<b>24</b>	<b>Legal information</b> .....	<b>47</b>
6.3.4	RAM writing in 1:3 multiplex drive mode .....	12			
6.3.5	Bank selection .....	13			
6.3.5.1	Output bank selector .....	13			
6.3.5.2	Input bank selector .....	14			
6.3.5.3	RAM bank switching .....	14			
6.4	Initialization .....	15			
6.4.1	Device initialization .....	15			
6.4.2	Device setup .....	16			
6.5	Possible display configurations .....	16			
6.6	LCD bias generator .....	17			
6.7	LCD voltage selector .....	17			
6.7.1	Electro-optical performance .....	19			
6.8	LCD drive mode waveforms .....	19			
6.8.1	Static drive mode .....	19			
6.8.2	1:2 Multiplex drive mode .....	20			
6.8.3	1:3 Multiplex drive mode .....	22			
6.8.4	1:4 Multiplex drive mode .....	23			
6.9	Backplane and segment outputs .....	24			
6.9.1	Backplane outputs .....	25			
6.9.2	Segment outputs .....	25			
<b>7</b>	<b>Characteristics of the I2C-bus</b> .....	<b>25</b>			
7.1	Bit transfer .....	25			
7.2	START and STOP conditions .....	25			
7.3	System configuration .....	26			
7.4	Acknowledge .....	26			
7.5	I2C-bus controller .....	27			
7.6	Input filters .....	27			
7.7	I2C-bus protocol .....	27			
<b>8</b>	<b>Internal circuitry</b> .....	<b>29</b>			

Please be aware that important notices concerning this document and the product(s) described herein, have been included in section 'Legal information'.

## Looking for pricing, stock, or lifecycle information?

Click below to explore more details on WIN SOURCE:

- ⊖ [View PCA85262ATT/AJ on WIN SOURCE](#)
- ⊖ [NXP / Nexperia Information](#)

## Optimize Your Supply Chain with WIN SOURCE Solutions

- ✓ Global Sourcing Solution
- ✓ Obsolete Management
- ✓ Cost Control Management
- ✓ Shortage Management
- ✓ Alternative Solution
- ✓ Excess Inventory Management