



**THE DATASHEET OF
PCA2129T/Q900/2**



PCA2129

Automotive accurate RTC with integrated quartz crystal

Rev. 6.0 — 18 July 2022

Product data sheet



1 General description

The PCA2129 is a CMOS¹ Real Time Clock (RTC) and calendar with an integrated Temperature Compensated Crystal (Xtal) Oscillator (TCXO) and a 32.768 kHz quartz crystal optimized for very high accuracy and very low power consumption. The PCA2129 has a selectable I²C-bus or SPI-bus, a backup battery switch-over circuit, a programmable watchdog function, a timestamp function, and many other features.

For a selection of NXP Real-Time Clocks, see [Table 82](#)

2 Features and benefits

- UL Recognized Component (PCA2129T/Q900/2)
- AEC-Q100 compliant for automotive applications
- Operating temperature range from -40 °C to +85 °C
- Temperature Compensated Crystal Oscillator (TCXO) with integrated capacitors
- Typical accuracy: ±3 ppm from -30 °C to +80 °C
- Integration of a 32.768 kHz quartz crystal and oscillator in the same package
- Provides year, month, day, weekday, hours, minutes, seconds, and leap year correction
- Timestamp function
 - with interrupt capability
 - detection of two different events on one multilevel input pin (for example, for tamper detection)
- Two line bidirectional 400 kHz Fast-mode I²C-bus interface
- 3 line SPI-bus with separate data input and output (maximum speed 6.5 Mbit/s)
- Battery backup input pin and switch-over circuitry
- Battery backed output voltage
- Battery low detection function
- Power-On Reset Override (PORO)
- Oscillator stop detection function
- Interrupt output (open-drain)
- Programmable 1 second or 1 minute interrupt
- Programmable watchdog timer with interrupt
- Programmable alarm function with interrupt capability
- Programmable square output
- Clock operating voltage: 1.8 V to 4.2 V
- Low supply current: typical 0.70 µA at V_{DD} = 3.3 V

¹ The definition of the abbreviations and acronyms used in this data sheet can be found in [Section 20](#).



3 Applications

- Electronic metering for electricity, water, and gas
- Precision timekeeping
- Access to accurate time of the day
- GPS equipment to reduce time to first fix
- Applications that require an accurate process timing
- Products with long automated unattended operation time

4 Ordering information

Table 1. Ordering information

Type number	Topside marking	Package		
		Name	Description	Version
PCA2129T/Q900/2	PCA2129T/Q	SO16	plastic small outline package; 16 leads; body width 7.5 mm	SOT162-1

4.1 Ordering options

Table 2. Ordering options

Type number	Orderable part number	Package	Packing method ^[1]	Minimum order quantity	Temperature
PCA2129T/Q900/2	PCA2129T/Q900/2,5	SO16	REEL 13" Q1/T1 DP	1000	T _{amb} = -40 °C to +85 °C

[1] Standard packing quantities and other packaging data are available at www.nxp.com/packages/.

5 Block diagram

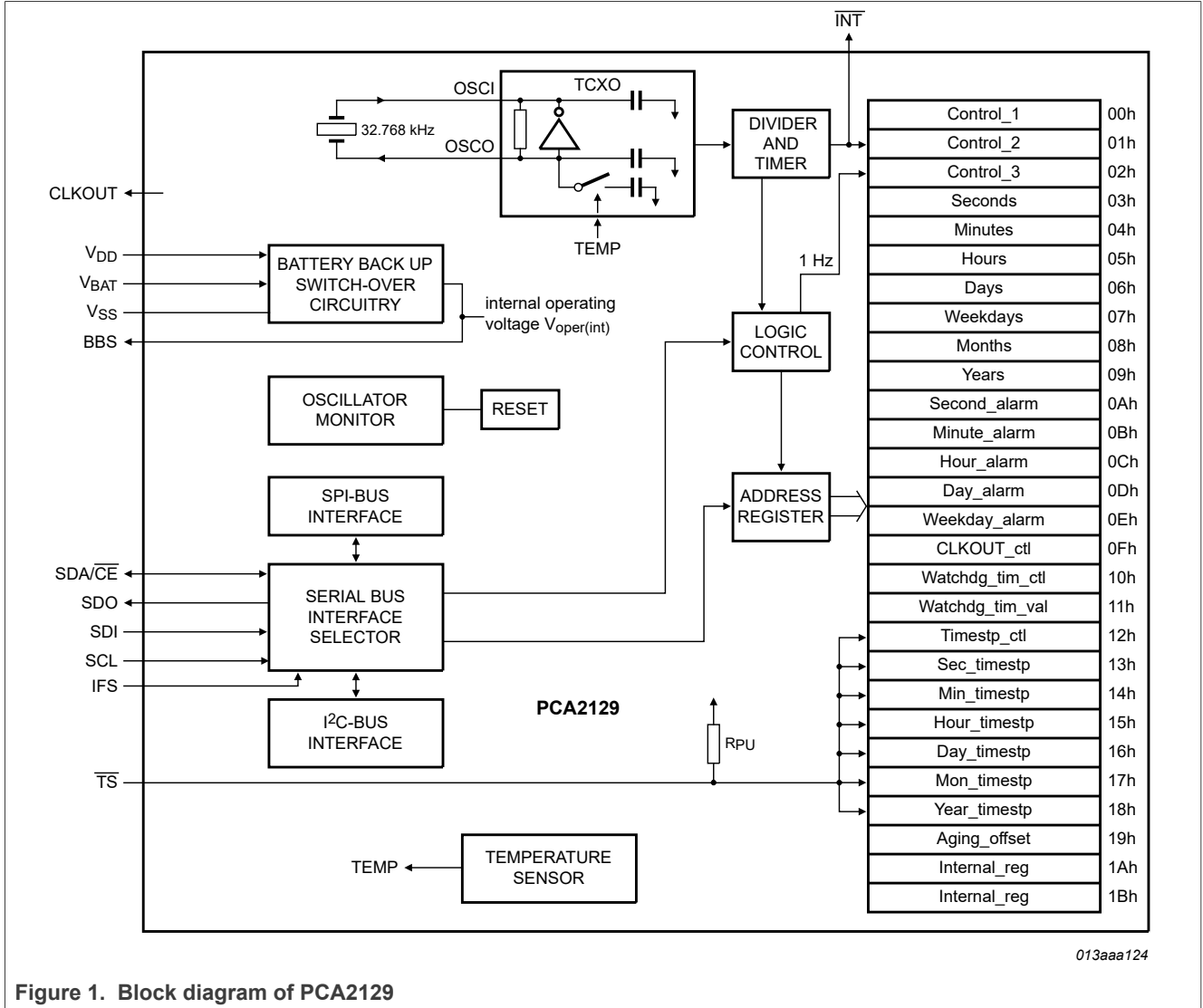
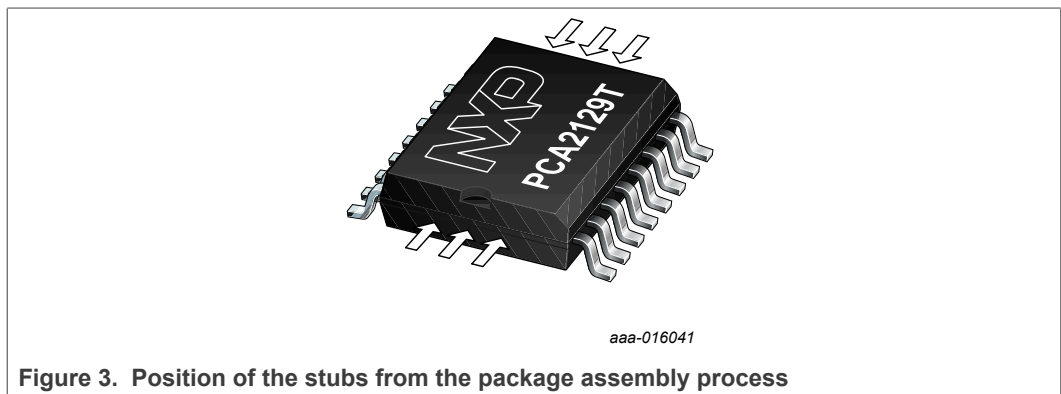
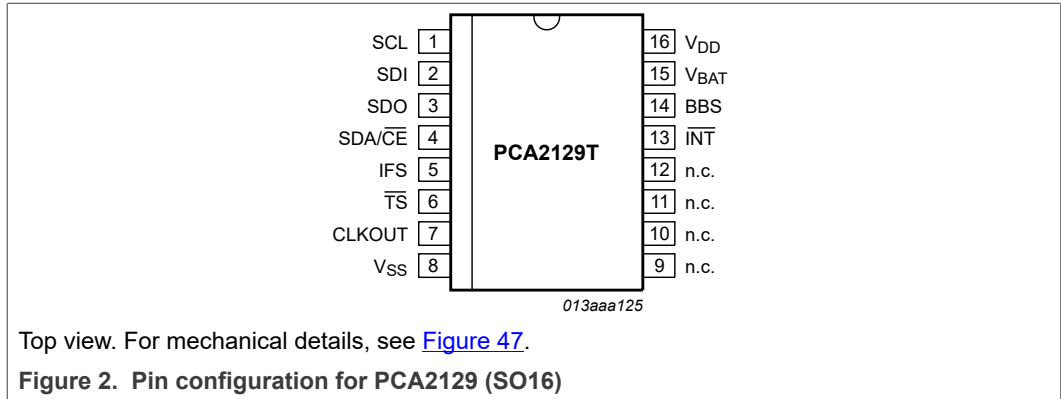

Figure 1. Block diagram of PCA2129

6 Pinning information

6.1 Pinning



After lead forming and cutting, there remain stubs from the package assembly process. These stubs are present at the edge of the package as illustrated in [Figure 3](#). The stubs are at an electrical potential. To avoid malfunction of the PCA2129, it has to be ensured that they are not shorted with another electrical potential (e.g. by condensation).

6.2 Pin description

Table 3. Pin description of PCA2129

Input or input/output pins must always be at a defined level (V_{SS} or V_{DD}) unless otherwise specified.

Symbol	Pin	Description
SCL	1	combined serial clock input for both I ² C-bus and SPI-bus
SDI	2	serial data input for SPI-bus connect to pin V_{SS} if I ² C-bus is selected
SDO	3	serial data output for SPI-bus, push-pull
SDA/CE	4	combined serial data input and output for the I ² C-bus and chip enable input (active LOW) for the SPI-bus

Table 3. Pin description of PCA2129...continued

Input or input/output pins must always be at a defined level (V_{SS} or V_{DD}) unless otherwise specified.

Symbol	Pin	Description
IFS	5	interface selector input connect to pin V_{SS} to select the SPI-bus connect to pin BBS to select the I ² C-bus
TS	6	timestamp input (active LOW) with 200 k Ω internal pull-up resistor (R_{PU})
CLKOUT	7	clock output (open-drain)
V_{SS}	8	ground supply voltage
n.c.	9 to 12	not connected; do not connect; do not use as feed through
INT	13	interrupt output (open-drain; active LOW)
BBS	14	output voltage (battery backed)
V_{BAT}	15	battery supply voltage (backup) connect to V_{SS} if battery switch over is not used
V_{DD}	16	supply voltage

7 Functional description

The PCA2129 is a Real Time Clock (RTC) and calendar with an on-chip Temperature Compensated Crystal (Xtal) Oscillator (TCXO) and a 32.768 kHz quartz crystal integrated into the same package (see [Section 7.3.3](#)).

Address and data are transferred by a selectable 400 kHz Fast-mode I²C-bus or a 3 line SPI-bus with separate data input and output (see [Section 8](#)). The maximum speed of the SPI-bus is 6.5 Mbit/s.

The PCA2129 has a backup battery input pin and backup battery switch-over circuit which monitors the main power supply. The backup battery switch-over circuit automatically switches to the backup battery when a power failure condition is detected (see [Section 7.5.1](#)). Accurate timekeeping is maintained even when the main power supply is interrupted.

A battery low detection circuit monitors the status of the battery (see [Section 7.5.2](#)). When the battery voltage drops below a certain threshold value, a flag is set to indicate that the battery must be replaced soon. This ensures the integrity of the data during periods of battery backup.

7.1 Register overview

The PCA2129 contains an auto-incrementing address register: the built-in address register will increment automatically after each read or write of a data byte up to the register 1Bh. After register 1Bh, the auto-incrementing will wrap around to address 00h (see [Figure 4](#)).

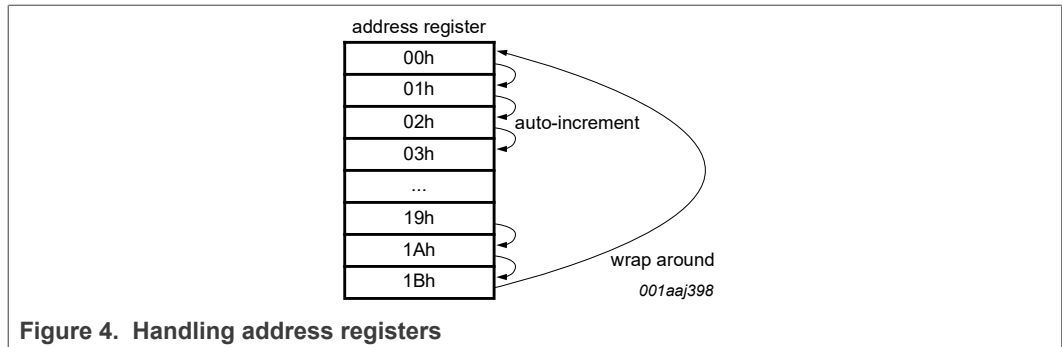

Figure 4. Handling address registers

- The first three registers (memory address 00h, 01h, and 02h) are used as control registers (see [Section 7.2](#)).
- The memory addresses 03h through to 09h are used as counters for the clock function (seconds up to years). The date is automatically adjusted for months with fewer than 31 days, including corrections for leap years. The clock can operate in 12-hour mode with an AM/PM indication or in 24-hour mode (see [Section 7.8](#)).
- The registers at addresses 0Ah through 0Eh define the alarm function. It can be selected that an interrupt is generated when an alarm event occurs (see [Section 7.9](#)).
- The register at address 0Fh defines the temperature measurement period and the clock out mode. The temperature measurement can be selected from every 4 minutes (default) down to every 30 seconds (see [Table 13](#)). CLKOUT frequencies of 32.768 kHz (default) down to 1 Hz for use as system clock, microcontroller clock, and so on, can be chosen (see [Table 14](#)).
- The registers at addresses 10h and 11h are used for the watchdog timer functions. The watchdog timer has four selectable source clocks allowing for timer periods from less than 1 ms to greater than 4 hours (see [Table 51](#)). An interrupt is generated when the watchdog times out.
- The registers at addresses 12h to 18h are used for the timestamp function. When the trigger event happens, the actual time is saved in the timestamp registers (see [Section 7.11](#)).
- The register at address 19h is used for the correction of the crystal aging effect (see [Section 7.4.1](#)).
- The registers at addresses 1Ah and 1Bh are for internal use only.
- The registers Seconds, Minutes, Hours, Days, Months, and Years are all coded in Binary Coded Decimal (BCD) format to simplify application use. Other registers are either bit-wise or standard binary.

When one of the RTC registers is written or read, the content of all counters is temporarily frozen. This prevents a faulty writing or reading of the clock and calendar during a carry condition (see [Section 7.8.8](#)).

Table 4. Register overview

Bit positions labeled as - are not implemented and return 0 when read. Bits labeled as T must always be written with logic 0. Bits labeled as X are undefined at power-on and unchanged by subsequent resets.

Address	Register name	Bit								Reset value	Reference
		7	6	5	4	3	2	1	0		
Control registers											
00h	Control_1	EXT_TEST	T	STOP	TSF1	POR_OVRD	12_24	MI	SI	0000 1000	Table 6
01h	Control_2	MSF	WDTF	TSF2	AF	T	TSIE	AIE	T	0000 0000	Table 8
02h	Control_3	PWRMNG[2:0]			BTSE	BF	BLF	BIE	BLIE	0000 0000	Table 10
Time and date registers											
03h	Seconds	OSF	SECONDS (0 to 59)						1XXX XXXX	Table 21	
04h	Minutes	-	MINUTES (0 to 59)						- XXX XXXX	Table 24	
05h	Hours	-	-	AMPM	HOURS (1 to 12) in 12-hour mode			-- XX XXXX	Table 26		
				HOURS (0 to 23) in 24-hour mode			-- XX XXXX				
06h	Days	-	-	DAYS (1 to 31)				-- XX XXXX	Table 28		
07h	Weekdays	-	-	-	-	-	WEEKDAYS (0 to 6)	----- XXX	Table 30		
08h	Months	-	-	-	MONTHS (1 to 12)			--- X XXXX	Table 33		
09h	Years	YEARS (0 to 99)						XXXX XXXX	Table 36		
Alarm registers											
0Ah	Second_alarm	AE_S	SECOND_ALARM (0 to 59)						1XXX XXXX	Table 38	
0Bh	Minute_alarm	AE_M	MINUTE_ALARM (0 to 59)						1XXX XXXX	Table 40	
0Ch	Hour_alarm	AE_H	-	AMPM	HOUR_ALARM (1 to 12) in 12-hour mode			1 - XX XXXX	Table 42		
				HOUR_ALARM (0 to 23) in 24-hour mode			1 - XX XXXX				
0Dh	Day_alarm	AE_D	-	DAY_ALARM (1 to 31)				1 - XX XXXX	Table 44		
0Eh	Weekday_alarm	AE_W	-	-	-	-	WEEKDAY_ALARM (0 to 6)	1 - - - - XXX	Table 46		
CLKOUT control register											
0Fh	CLKOUT_ctl	TCR[1:0]	OTPR	-	-	COF[2:0]		00X - - 000	Table 12		

Table 4. Register overview...continued

Bit positions labeled as - are not implemented and return 0 when read. Bits labeled as T must always be written with logic 0. Bits labeled as X are undefined at power-on and unchanged by subsequent resets.

Address	Register name	Bit								Reset value	Reference
		7	6	5	4	3	2	1	0		
Watchdog registers											
10h	Watchdog_tim_ctl	WD_CD	T	TI_TP	-	-	-	TF[1:0]		000 - - - 11	Table 48
11h	Watchdog_tim_val	WATCHDOG_TIM_VAL[7:0]								XXXX XXXX	Table 50
Timestamp registers											
12h	Timestamp_ctl	TSM	TSOFF	-	1_O_16_TIMESTAMP[4:0]				00 - X XXXX	Table 57	
13h	Sec_timestp	-	SECOND_TIMESTAMP (0 to 59)					- XXX XXXX	Table 59		
14h	Min_timestp	-	MINUTE_TIMESTAMP (0 to 59)					- XXX XXXX	Table 61		
15h	Hour_timestp	-	-	AMPM	HOUR_TIMESTAMP (1 to 12) in 12-hour mode				- - XX XXXX	Table 63	
				HOUR_TIMESTAMP (0 to 23) in 24-hour mode				- - XX XXXX			
16h	Day_timestp	-	-	DAY_TIMESTAMP (1 to 31)				- - XX XXXX	Table 65		
17h	Mon_timestp	-	-	-	MONTH_TIMESTAMP (1 to 12)				- - - X XXXX	Table 67	
18h	Year_timestp	YEAR_TIMESTAMP (0 to 99)							XXXX XXXX	Table 69	
Aging offset register											
19h	Aging_offset	-	-	-	-	AO[3:0]			- - - - 1000	Table 16	
Internal registers											
1Ah	Internal_reg	-	-	-	-	-	-	-	-	- - - - - - - -	-
1Bh	Internal_reg	-	-	-	-	-	-	-	-	- - - - - - - -	-

7.2 Control registers

The first 3 registers of the PCA2129, with the addresses 00h, 01h, and 02h, are used as control registers.

7.2.1 Register Control_1

Table 5. Control_1 - control and status register 1 (address 00h) bit allocation

Bits labeled as *T* must always be written with logic 0.

Bit	7	6	5	4	3	2	1	0
Symbol	EXT_TEST	T	STOP	TSF1	POR_OVRD	12_24	MI	SI
Reset value	0	0	0	0	1	0	0	0

Table 6. Control_1 - control and status register 1 (address 00h) bit description

Bits labeled as *T* must always be written with logic 0.

Bit	Symbol	Value	Description	Reference
7	EXT_TEST	0	normal mode	Section 7.13
		1	external clock test mode	
6	T	0	unused	-
5	STOP	0	RTC source clock runs	Section 7.14
		1	RTC clock is stopped; RTC divider chain flip-flops are asynchronously set logic 0; CLKOUT at 32.768 kHz, 16.384 kHz, or 8.192 kHz is still available	
4	TSF1	0	no timestamp interrupt generated	Section 7.11.1
		1	flag set when TS input is driven to an intermediate level between power supply and ground; flag must be cleared to clear interrupt	
3	POR_OVRD	0	Power-On Reset Override (PORO) facility disabled; set logic 0 for normal operation	Section 7.7.2
		1	Power-On Reset Override (PORO) sequence reception enabled	
2	12_24	0	24-hour mode selected	Table 26, Table 42, Table 43, Table 63
		1	12-hour mode selected	
1	MI	0	minute interrupt disabled	Section 7.12.1
		1	minute interrupt enabled	
0	SI	0	second interrupt disabled	
		1	second interrupt enabled	

7.2.2 Register Control_2

Table 7. Control_2 - control and status register 2 (address 01h) bit allocation

Bits labeled as T must always be written with logic 0.

Bit	7	6	5	4	3	2	1	0
Symbol	MSF	WDTF	TSF2	AF	T	TSIE	AIE	T
Reset value	0	0	0	0	0	0	0	0

Table 8. Control_2 - control and status register 2 (address 01h) bit description

Bits labeled as T must always be written with logic 0.

Bit	Symbol	Value	Description	Reference
7	MSF	0	no minute or second interrupt generated	Section 7.12
		1	flag set when minute or second interrupt generated; flag must be cleared to clear interrupt	
6	WDTF	0	no watchdog timer interrupt or reset generated	Section 7.12.3
		1	flag set when watchdog timer interrupt or reset generated; flag cannot be cleared by command (read-only)	
5	TSF2	0	no timestamp interrupt generated	Section 7.11.1
		1	flag set when \overline{TS} input is driven to ground; flag must be cleared to clear interrupt	
4	AF	0	no alarm interrupt generated	Section 7.9.6
		1	flag set when alarm triggered; flag must be cleared to clear interrupt	
3	T	0	unused	-
2	TSIE	0	no interrupt generated from timestamp flag	Section 7.12.5
		1	interrupt generated when timestamp flag set	
1	AIE	0	no interrupt generated from the alarm flag	Section 7.12.4
		1	interrupt generated when alarm flag set	
0	T	0	unused	-

7.2.3 Register Control_3

Table 9. Control_3 - control and status register 3 (address 02h) bit allocation

Bit	7	6	5	4	3	2	1	0
Symbol	PWRMNG[2:0]			BTSE	BF	BLF	BIE	BLIE
Reset value	0	0	0	0	0	0	0	0

Table 10. Control_3 - control and status register 3 (address 02h) bit description

Bit	Symbol	Value	Description	Reference
7 to 5	PWRMNG[2:0]	see Table 18	control of the battery switch-over, battery low detection, and extra power fail detection functions	Section 7.5
4	BTSE	0	no timestamp when battery switch-over occurs	Section 7.11.4
		1	time-stamped when battery switch-over occurs	
3	BF	0	no battery switch-over interrupt generated	Section 7.5.1 and Section 7.11.4
		1	flag set when battery switch-over occurs; flag must be cleared to clear interrupt	
2	BLF	0	battery status ok; no battery low interrupt generated	Section 7.5.2
		1	battery status low; flag cannot be cleared by command	
1	BIE	0	no interrupt generated from the battery flag (BF)	Section 7.12.6
		1	interrupt generated when BF is set	
0	BLIE	0	no interrupt generated from battery low flag (BLF)	Section 7.12.7
		1	interrupt generated when BLF is set	

7.3 Register CLKOUT_ctl

Table 11. CLKOUT_ctl - CLKOUT control register (address 0Fh) bit allocation

Bit positions labeled as - are not implemented and return 0 when read. Bits labeled as X are undefined at power-on and unchanged by subsequent resets.

Bit	7	6	5	4	3	2	1	0
Symbol	TCR[1:0]		OTPR	-	-	COF[2:0]		
Reset value	0	0	X	-	-	0	0	0

Table 12. CLKOUT_ctl - CLKOUT control register (address 0Fh) bit description

Bit positions labeled as - are not implemented and return 0 when read. Bits labeled as X are undefined at power-on and unchanged by subsequent resets.

Bit	Symbol	Value	Description
7 to 6	TCR[1:0]	see Table 13	temperature measurement period
5	OTPR	0	no OTP refresh
		1	OTP refresh performed
4 to 3	-	-	unused
2 to 0	COF[2:0]	see Table 14	CLKOUT frequency selection

7.3.1 Temperature compensated crystal oscillator

The frequency of tuning fork quartz crystal oscillators is temperature-dependent. In the PCA2129, the frequency deviation caused by temperature variation is corrected by adjusting the load capacitance of the crystal oscillator.

The load capacitance is changed by switching between two load capacitance values using a modulation signal with a programmable duty cycle. In order to compensate the spread of the quartz parameters every chip is factory calibrated.

The frequency accuracy can be evaluated by measuring the frequency of the square wave signal available at the output pin CLKOUT. However, the selection of $f_{CLKOUT} = 32.768$ kHz (default value) leads to inaccurate measurements. Accurate frequency measurement occurs when $f_{CLKOUT} = 16.384$ kHz or lower is selected (see [Table 14](#)).

7.3.1.1 Temperature measurement

The PCA2129 has a temperature sensor circuit used to perform the temperature compensation of the frequency. The temperature is measured immediately after power-on and then periodically with a period set by the temperature conversion rate TCR[1:0] in the register CLKOUT_ctl.

Table 13. Temperature measurement period

TCR[1:0]		Temperature measurement period
00	[1]	4 min
01		2 min
10		1 min
11		30 seconds

[1] Default value.

7.3.2 OTP refresh

Each IC is calibrated during production and testing of the device. The calibration parameters are stored on EPROM cells called One Time Programmable (OTP) cells. It is recommended to process an OTP refresh once after the power is up and the oscillator is operating stable. The OTP refresh takes less than 100 ms to complete.

To perform an OTP refresh, bit OTPR has to be cleared (set to logic 0) and then set to logic 1 again.

7.3.3 Clock output

A programmable square wave is available at pin CLKOUT. Operation is controlled by the COF[2:0] control bits in register CLKOUT_ctl. Frequencies of 32.768 kHz (default) down to 1 Hz can be generated for use as system clock, microcontroller clock, charge pump input, or for calibrating the oscillator.

CLKOUT is an open-drain output and enabled at power-on. When disabled, the output is high-impedance.

Table 14. CLKOUT frequency selection

COF[2:0]		CLKOUT frequency (Hz)	Typical duty cycle ^[1]
000	[2][3]	32 768	60 : 40 to 40 : 60
001		16 384	50 : 50
010		8 192	50 : 50
011		4 096	50 : 50
100		2 048	50 : 50

Table 14. CLKOUT frequency selection...continued

COF[2:0]	CLKOUT frequency (Hz)	Typical duty cycle ^[1]
101	1 024	50 : 50
110	1	50 : 50
111	CLKOUT = high-Z	-

- [1] Duty cycle definition: % HIGH-level time : % LOW-level time.
- [2] Default value.
- [3] The specified accuracy of the RTC can be only achieved with CLKOUT frequencies not equal to 32.768 kHz or if CLKOUT is disabled.

The duty cycle of the selected clock is not controlled, however, due to the nature of the clock generation all but the 32.768 kHz frequencies are 50 : 50.

7.4 Register Aging_offset

Table 15. Aging_offset - crystal aging offset register (address 19h) bit allocation

Bit positions labeled as - are not implemented and return 0 when read.

Bit	7	6	5	4	3	2	1	0
Symbol	-	-	-	-	AO[3:0]			
Reset value	-	-	-	-	1	0	0	0

Table 16. Aging_offset - crystal aging offset register (address 19h) bit description

Bit positions labeled as - are not implemented and return 0 when read.

Bit	Symbol	Value	Description
7 to 4	-	-	unused
3 to 0	AO[3:0]	see Table 17	aging offset value

7.4.1 Crystal aging correction

The PCA2129 has an offset register Aging_offset to correct the crystal aging effects².

The accuracy of the frequency of a quartz crystal depends on its aging. The aging offset adds an adjustment, positive or negative, in the temperature compensation circuit which allows correcting the aging effect.

At 25 °C, the aging offset bits allow a frequency correction of typically 1 ppm per AO[3:0] value, from -7 ppm to +8 ppm.

Table 17. Frequency correction at 25 °C, typical

AO[3:0]		ppm
Decimal	Binary	
0	0000	+8
1	0001	+7
2	0010	+6

² For further information, refer to the application note [\[1\]](#).

Table 17. Frequency correction at 25 °C, typical...continued

AO[3:0]		ppm
Decimal	Binary	
3	0011	+5
4	0100	+4
5	0101	+3
6	0110	+2
7	0111	+1
8	1000	^[1] 0
9	1001	-1
10	1010	-2
11	1011	-3
12	1100	-4
13	1101	-5
14	1110	-6
15	1111	-7

[1] Default value.

7.5 Power management functions

The PCA2129 has two power supplies:

V_{DD}

the main power supply

V_{BAT}

the battery backup supply

Internally, the PCA2129 is operating with the internal operating voltage $V_{oper(int)}$ which is also available as V_{BBS} on the battery backed output voltage pin, BBS. Depending on the condition of the main power supply and the selected power management function, $V_{oper(int)}$ is either on the potential of V_{DD} or V_{BAT} (see [Section 7.5.3](#)).

Two power management functions are implemented:

Battery switch-over function

monitoring the main power supply V_{DD} and switching to V_{BAT} in case a power fail condition is detected (see [Section 7.5.1](#)).

Battery low detection function

monitoring the status of the battery, V_{BAT} (see [Section 7.5.2](#)).

The power management functions are controlled by the control bits PWRMNG[2:0] (see [Table 18](#)) in register Control_3 (see [Table 10](#)):

Table 18. Power management control bit description

PWRMNG[2:0]		Function
000	[1]	battery switch-over function is enabled in standard mode; battery low detection function is enabled
001		battery switch-over function is enabled in standard mode; battery low detection function is disabled
010		battery switch-over function is enabled in standard mode; battery low detection function is disabled
011		battery switch-over function is enabled in direct switching mode; battery low detection function is enabled
100		battery switch-over function is enabled in direct switching mode; battery low detection function is disabled
101		battery switch-over function is enabled in direct switching mode; battery low detection function is disabled
111	[2]	battery switch-over function is disabled, only one power supply (V_{DD}); battery low detection function is disabled

[1] Default value.

[2] When the battery switch-over function is disabled, the PCA2129 works only with the power supply V_{DD} . V_{BAT} must be put to ground and the battery low detection function is disabled.

7.5.1 Battery switch-over function

The PCA2129 has a backup battery switch-over circuit which monitors the main power supply V_{DD} . When a power failure condition is detected, it automatically switches to the backup battery.

One of two operation modes can be selected:

Standard mode

the power failure condition happens when:

$$V_{DD} < V_{BAT} \text{ AND } V_{DD} < V_{th(sw)bat}$$

$V_{th(sw)bat}$ is the battery switch threshold voltage. Typical value is 2.5 V. The battery switch-over in standard mode works only for $V_{DD} > 2.5 \text{ V}$

Direct switching mode

the power failure condition happens when $V_{DD} < V_{BAT}$. Direct switching from V_{DD} to V_{BAT} without requiring V_{DD} to drop below $V_{th(sw)bat}$

When a power failure condition occurs and the power supply switches to the battery, the following sequence occurs:

1. The battery switch flag BF (register Control_3) is set logic 1.
2. An interrupt is generated if the control bit BIE (register Control_3) is enabled (see [Section 7.12.6](#)).
3. If the control bit BTSE (register Control_3) is logic 1, the timestamp registers store the time and date when the battery switch occurred (see [Section 7.11.4](#)).
4. The battery switch flag BF is cleared by command; it must be cleared to clear the interrupt.

The interface is disabled in battery backup operation:

- Interface inputs are not recognized, preventing extraneous data being written to the device
- Interface outputs are high-impedance

For further information about I²C-bus communication and battery backup operation, see [Section 8.3](#).

7.5.1.1 Standard mode

If $V_{DD} > V_{BAT}$ OR $V_{DD} > V_{th(sw)bat}$: $V_{oper(int)}$ is at V_{DD} potential.

If $V_{DD} < V_{BAT}$ AND $V_{DD} < V_{th(sw)bat}$: $V_{oper(int)}$ is at V_{BAT} potential.

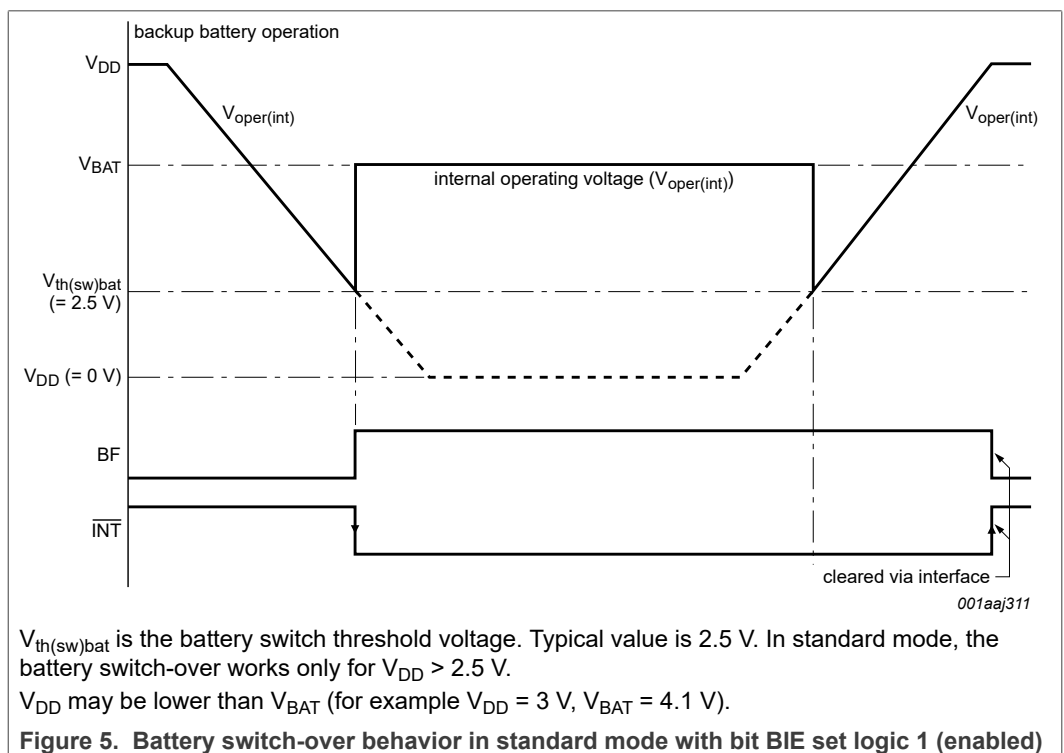

7.5.1.2 Direct switching mode

If $V_{DD} > V_{BAT}$: $V_{oper(int)}$ is at V_{DD} potential.

If $V_{DD} < V_{BAT}$: $V_{oper(int)}$ is at V_{BAT} potential.

The direct switching mode is useful in systems where V_{DD} is always higher than V_{BAT} . This mode is not recommended if the V_{DD} and V_{BAT} values are similar (for example, $V_{DD} = 3.3$ V, $V_{BAT} \geq 3.0$ V). In direct switching mode, the power consumption is reduced compared to the standard mode because the monitoring of V_{DD} and $V_{th(sw)bat}$ is not performed.

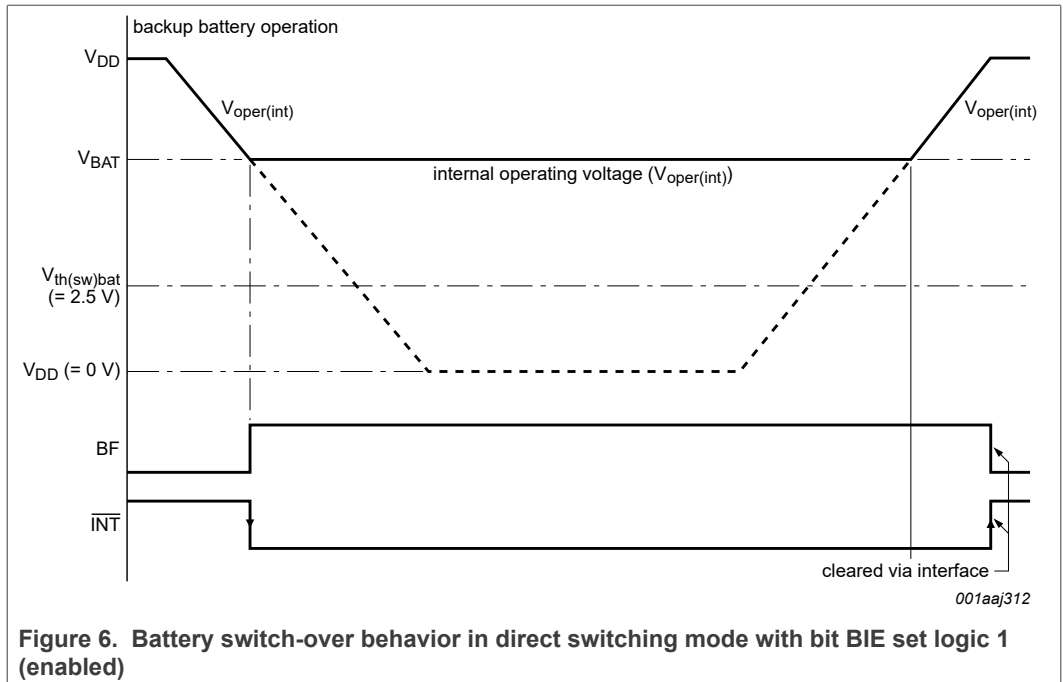

7.5.1.3 Battery switch-over disabled: only one power supply (V_{DD})

When the battery switch-over function is disabled:

- The power supply is applied on the V_{DD} pin
- The V_{BAT} pin must be connected to ground
- V_{oper(int)} is at V_{DD} potential
- The battery flag (BF) is always logic 0

7.5.1.4 Battery switch-over architecture

The architecture of the battery switch-over circuit is shown in [Figure 7](#).

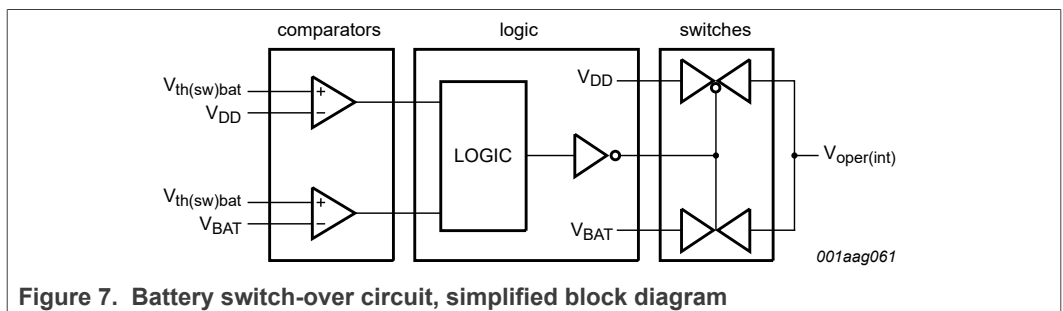

V_{oper(int)} is at V_{DD} or V_{BAT} potential.

Remark: It has to be assured that there are decoupling capacitors on the pins V_{DD}, V_{BAT}, and BBS.

7.5.2 Battery low detection function

The PCA2129 has a battery low detection circuit which monitors the status of the battery V_{BAT}.

When V_{BAT} drops below the threshold value $V_{th(bat)low}$ (typically 2.5 V), the BLF flag (register Control_3) is set to indicate that the battery is low and that it must be replaced. Monitoring of the battery voltage also occurs during battery operation.

An unreliable battery cannot prevent that the supply voltage drops below V_{low} (typical 1.2 V) and with that the data integrity gets lost. (For further information about V_{low} see [Section 7.6.](#))

When V_{BAT} drops below the threshold value $V_{th(bat)low}$, the following sequence occurs (see [Figure 8](#)):

1. The battery low flag BLF is set logic 1.
2. An interrupt is generated if the control bit BLIE (register Control_3) is enabled (see [Section 7.12.7](#)).
3. The flag BLF remains logic 1 until the battery is replaced. BLF cannot be cleared by command. It is automatically cleared by the battery low detection circuit when the battery is replaced or when the voltage rises again above the threshold value. This could happen if a super capacitor is used as a backup source and the main power is applied again.

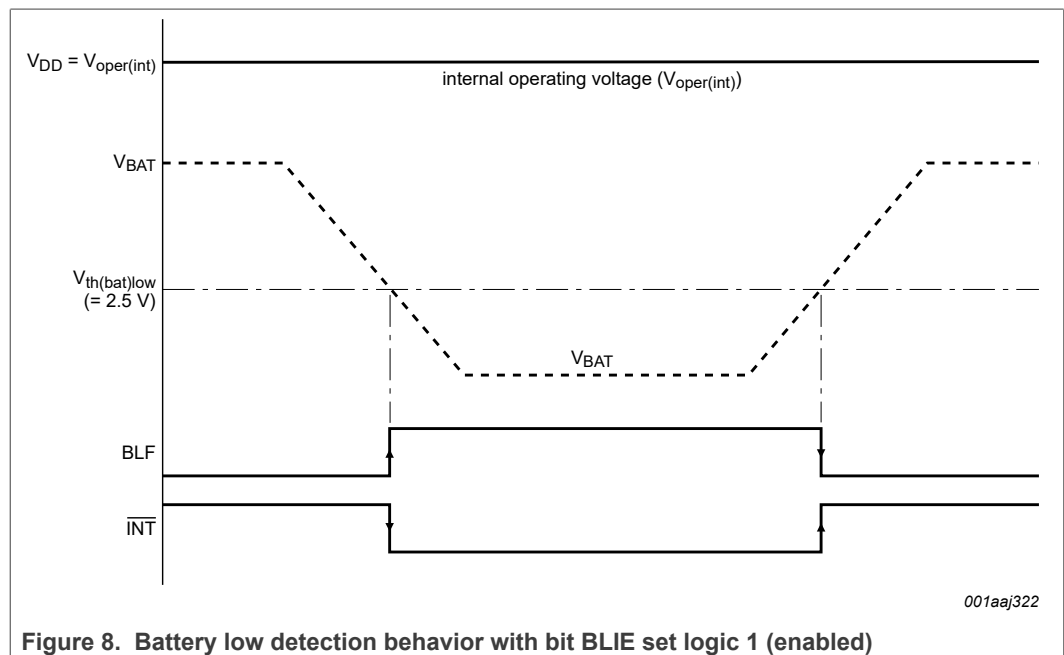

Figure 8. Battery low detection behavior with bit BLIE set logic 1 (enabled)

7.5.3 Battery backup supply

The V_{BBS} voltage on the output pin BBS is at the same potential as the internal operating voltage $V_{oper(int)}$, depending on the selected battery switch-over function mode:

Table 19. Output pin BBS

Battery switch-over function mode	Conditions	Potential of $V_{oper(int)}$ and V_{BBS}
standard	$V_{DD} > V_{BAT}$ OR $V_{DD} > V_{th(sw)bat}$	V_{DD}
	$V_{DD} < V_{BAT}$ AND $V_{DD} < V_{th(sw)bat}$	V_{BAT}
direct switching	$V_{DD} > V_{BAT}$	V_{DD}

Table 19. Output pin BBS...continued

Battery switch-over function mode	Conditions	Potential of $V_{oper(int)}$ and V_{BBS}
	$V_{DD} < V_{BAT}$	V_{BAT}
disabled	only V_{DD} available, V_{BAT} must be put to ground	V_{DD}

The output pin BBS can be used as a supply for external devices with battery backup needs, such as SRAM (see [1]). For this case, Figure 9 shows the typical driving capability when V_{BBS} is driven from V_{DD} .

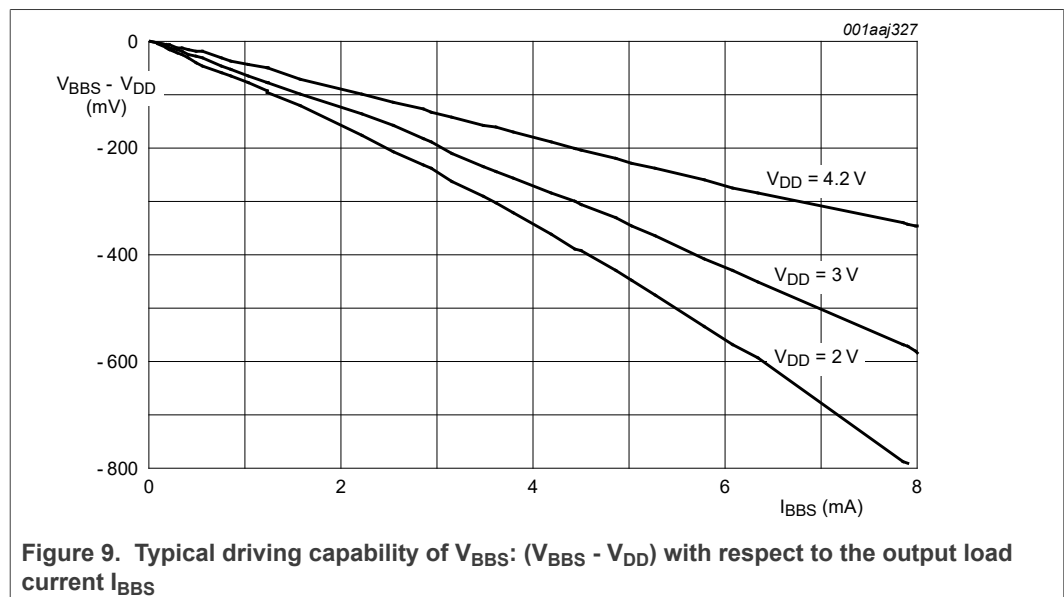

Figure 9. Typical driving capability of V_{BBS} : ($V_{BBS} - V_{DD}$) with respect to the output load current I_{BBS}

7.6 Oscillator stop detection function

The PCA2129 has an on-chip oscillator detection circuit which monitors the status of the oscillation: whenever the oscillation stops, a reset occurs and the oscillator stop flag OSF (in register Seconds) is set logic 1.

- **Power-on:**

1. The oscillator is not running, the chip is in reset (OSF is logic 1).
2. When the oscillator starts running and is stable after power-on, the chip exits from reset.
3. The flag OSF is still logic 1 and can be cleared (OSF set logic 0) by command.

- **Power supply failure:**

1. When the power supply of the chip drops below a certain value (V_{low}), typically 1.2 V, the oscillator stops running and a reset occurs.
2. When the power supply returns to normal operation, the oscillator starts running again, the chip exits from reset.
3. The flag OSF is still logic 1 and can be cleared (OSF set logic 0) by command.

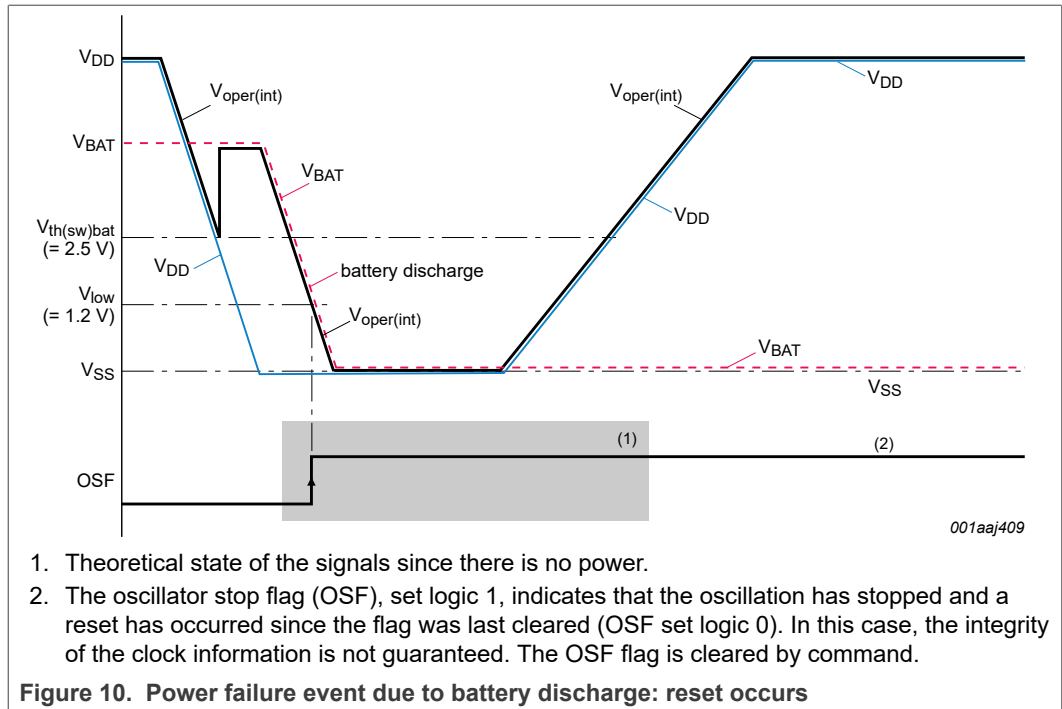

7.7 Reset function

The PCA2129 has a Power-On Reset (POR) and a Power-On Reset Override (PORO) function implemented.

7.7.1 Power-On Reset (POR)

The POR is active whenever the oscillator is stopped. The oscillator is considered to be stopped during the time between power-on and stable crystal resonance (see [Figure 11](#)). This time may be in the range of 200 ms to 2 s depending on temperature and supply voltage. Whenever an internal reset occurs, the oscillator stop flag is set (OSF set logic 1).

The OTP refresh (see [Section 7.3.2](#)) should ideally be executed as the first instruction after start-up and also after a reset due to an oscillator stop.

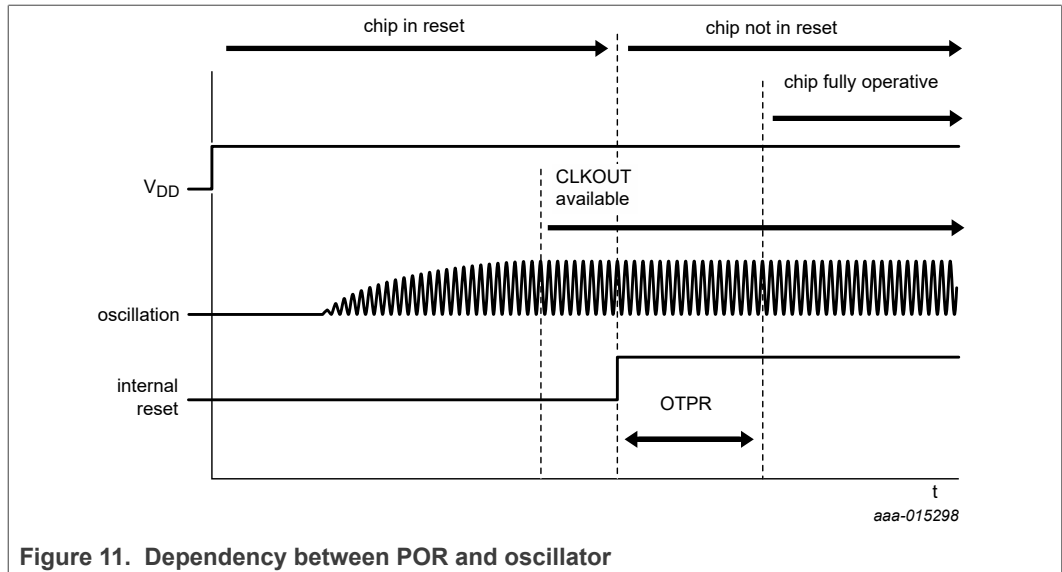

After POR, the following mode is entered:

- 32.768 kHz CLKOUT active
- Power-On Reset Override (PORO) available to be set
- 24-hour mode is selected
- Battery switch-over is enabled
- Battery low detection is enabled

The register values after power-on are shown in [Table 4](#).

7.7.2 Power-On Reset Override (PORO)

The POR duration is directly related to the crystal oscillator start-up time. Due to the long start-up times experienced by these types of circuits, a mechanism has been built in to disable the POR and therefore speed up the on-board test of the device.

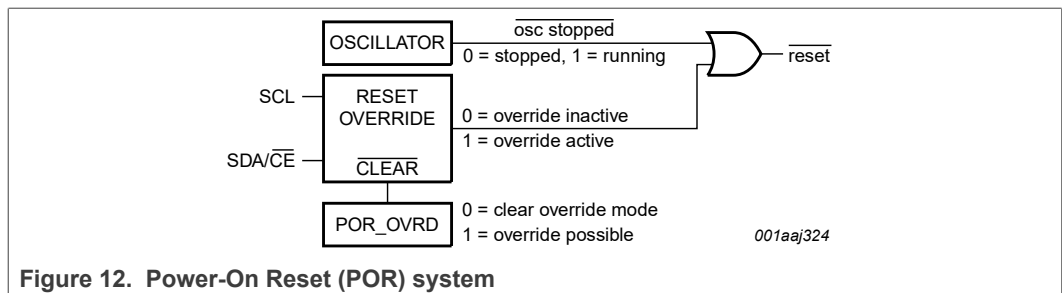

The setting of the PORO mode requires that POR_OVRD in register Control_1 is set logic 1 and that the signals at the interface pins SDA/CÉ and SCL are toggled as illustrated in [Figure 13](#). All timings shown are required minimum.

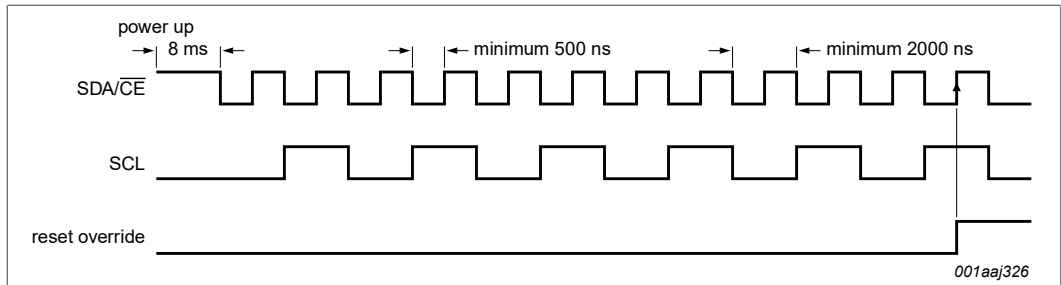

Figure 13. Power-On Reset Override (PORO) sequence, valid for both I²C-bus and SPI-bus

Once the override mode is entered, the device is immediately released from the reset state and the set-up operation can commence.

The PORO mode is cleared by writing logic 0 to POR_OVRD. POR_OVRD must be logic 1 before a re-entry into the override mode is possible. Setting POR_OVRD logic 0 during normal operation has no effect except to prevent accidental entry into the PORO mode.

7.8 Time and date function

Most of these registers are coded in the Binary Coded Decimal (BCD) format.

7.8.1 Register Seconds

Table 20. Seconds - seconds and clock integrity register (address 03h) bit allocation

Bits labeled as X are undefined at power-on and unchanged by subsequent resets.

Bit	7	6	5	4	3	2	1	0
Symbol	OSF	SECONDS (0 to 59)						
Reset value	1	X	X	X	X	X	X	X

Table 21. Seconds - seconds and clock integrity register (address 03h) bit description

Bits labeled as X are undefined at power-on and unchanged by subsequent resets.

Bit	Symbol	Value	Place value	Description
7	OSF	0	-	clock integrity is guaranteed
		1	-	clock integrity is not guaranteed: oscillator has stopped and chip reset has occurred since flag was last cleared
6 to 4	SECONDS	0 to 5	ten's place	actual seconds coded in BCD format
3 to 0		0 to 9	unit place	

Table 22. Seconds coded in BCD format

Seconds value in decimal	Upper-digit (ten's place)			Digit (unit place)			
	Bit 6	Bit 5	Bit 4	Bit 3	Bit 2	Bit 1	Bit 0
00	0	0	0	0	0	0	0

Table 22. Seconds coded in BCD format...continued

Seconds value in decimal	Upper-digit (ten's place)			Digit (unit place)			
	Bit 6	Bit 5	Bit 4	Bit 3	Bit 2	Bit 1	Bit 0
01	0	0	0	0	0	0	1
02	0	0	0	0	0	1	0
:	:	:	:	:	:	:	:
09	0	0	0	1	0	0	1
10	0	0	1	0	0	0	0
:	:	:	:	:	:	:	:
58	1	0	1	1	0	0	0
59	1	0	1	1	0	0	1

7.8.2 Register Minutes

Table 23. Minutes - minutes register (address 04h) bit allocation

Bit positions labeled as - are not implemented and return 0 when read. Bits labeled as X are undefined at power-on and unchanged by subsequent resets.

Bit	7	6	5	4	3	2	1	0
Symbol	-	MINUTES (0 to 59)						
Reset value	-	X	X	X	X	X	X	X

Table 24. Minutes - minutes register (address 04h) bit description

Bit positions labeled as - are not implemented and return 0 when read. Bits labeled as X are undefined at power-on and unchanged by subsequent resets.

Bit	Symbol	Value	Place value	Description
7	-	-	-	unused
6 to 4	MINUTES	0 to 5	ten's place	actual minutes coded in BCD format
3 to 0		0 to 9	unit place	

7.8.3 Register Hours

Table 25. Hours - hours register (address 05h) bit allocation

Bit positions labeled as - are not implemented and return 0 when read. Bits labeled as X are undefined at power-on and unchanged by subsequent resets.

Bit	7	6	5	4	3	2	1	0
Symbol	-	-	AMPM	HOURS (1 to 12) in 12-hour mode				
				HOURS (0 to 23) in 24-hour mode				
Reset value	-	-	X	X	X	X	X	X

Table 26. Hours - hours register (address 05h) bit description

Bit positions labeled as - are not implemented and return 0 when read. Bits labeled as X are undefined at power-on and unchanged by subsequent resets.

Bit	Symbol	Value	Place value	Description
7 to 6	-	-	-	unused
12-hour mode^[1]				
5	AMPM	0	-	indicates AM
		1	-	indicates PM
4	HOURS	0 to 1	ten's place	actual hours coded in BCD format when in 12-hour mode
3 to 0		0 to 9	unit place	
24-hour mode^[1]				
5 to 4	HOURS	0 to 2	ten's place	actual hours coded in BCD format when in 24-hour mode
3 to 0		0 to 9	unit place	

[1] Hour mode is set by the bit 12_24 in register Control_1 (see [Table 6](#)).

7.8.4 Register Days

Table 27. Days - days register (address 06h) bit allocation

Bit positions labeled as - are not implemented and return 0 when read. Bits labeled as X are undefined at power-on and unchanged by subsequent resets.

Bit	7	6	5	4	3	2	1	0
Symbol	-	-	DAYS (1 to 31)					
Reset value	-	-	X	X	X	X	X	X

Table 28. Days - days register (address 06h) bit description

Bit	Symbol	Value	Place value	Description
7 to 6	-	-	-	unused
5 to 4	DAYS ^[1]	0 to 3	ten's place	actual day coded in BCD format
3 to 0		0 to 9	unit place	

[1] If the year counter contains a value which is exactly divisible by 4, including the year 00, the RTC compensates for leap years by adding a 29th day to February.

7.8.5 Register Weekdays

Table 29. Weekdays - weekdays register (address 07h) bit allocation

Bit positions labeled as - are not implemented and return 0 when read. Bits labeled as X are undefined at power-on and unchanged by subsequent resets.

Bit	7	6	5	4	3	2	1	0
Symbol	-	-	-	-	-	WEEKDAYS (0 to 6)		
Reset value	-	-	-	-	-	X	X	X

Table 30. Weekdays - weekdays register (address 07h) bit description

Bit positions labeled as - are not implemented and return 0 when read. Bits labeled as X are undefined at power-on and unchanged by subsequent resets.

Bit	Symbol	Value	Description
7 to 3	-	-	unused
2 to 0	WEEKDAYS	0 to 6	actual weekday value, see Table 31

Although the association of the weekdays counter to the actual weekday is arbitrary, the PCA2129 assumes that Sunday is 000 and Monday is 001 for the purpose of determining the increment for calendar weeks.

Table 31. Weekday assignments

Day ^[1]	Bit		
	2	1	0
Sunday	0	0	0
Monday	0	0	1
Tuesday	0	1	0
Wednesday	0	1	1
Thursday	1	0	0
Friday	1	0	1
Saturday	1	1	0

[1] Definition may be reassigned by the user.

7.8.6 Register Months

Table 32. Months - months register (address 08h) bit allocation

Bit positions labeled as - are not implemented and return 0 when read. Bits labeled as X are undefined at power-on and unchanged by subsequent resets.

Bit	7	6	5	4	3	2	1	0
Symbol	-	-	-	MONTHS (1 to 12)				
Reset value	-	-	-	X	X	X	X	X

Table 33. Months - months register (address 08h) bit description

Bit positions labeled as - are not implemented and return 0 when read. Bits labeled as X are undefined at power-on and unchanged by subsequent resets.

Bit	Symbol	Value	Place value	Description
7 to 5	-	-	-	unused
4	MONTHS	0 to 1	ten's place	actual month coded in BCD format, see Table 34
3 to 0		0 to 9	unit place	

Table 34. Month assignments in BCD format

Month	Upper-digit (ten's place)	Digit (unit place)			
	Bit 4	Bit 3	Bit 2	Bit 1	Bit 0
January	0	0	0	0	1
February	0	0	0	1	0
March	0	0	0	1	1
April	0	0	1	0	0
May	0	0	1	0	1
June	0	0	1	1	0
July	0	0	1	1	1
August	0	1	0	0	0
September	0	1	0	0	1
October	1	0	0	0	0
November	1	0	0	0	1
December	1	0	0	1	0

7.8.7 Register Years

Table 35. Years - years register (address 09h) bit allocation

Bits labeled as X are undefined at power-on and unchanged by subsequent resets.

Bit	7	6	5	4	3	2	1	0
Symbol	YEARS (0 to 99)							
Reset value	X	X	X	X	X	X	X	X

Table 36. Years - years register (address 09h) bit description

Bits labeled as X are undefined at power-on and unchanged by subsequent resets.

Bit	Symbol	Value	Place value	Description
7 to 4	YEARS	0 to 9	ten's place	actual year coded in BCD format
3 to 0		0 to 9	unit place	

7.8.8 Setting and reading the time

[Figure 14](#) shows the data flow and data dependencies starting from the 1 Hz clock tick.

During read/write operations, the time counting circuits (memory locations 03h through 09h) are blocked.

This prevents

- Faulty reading of the clock and calendar during a carry condition
- Incrementing the time registers during the read cycle

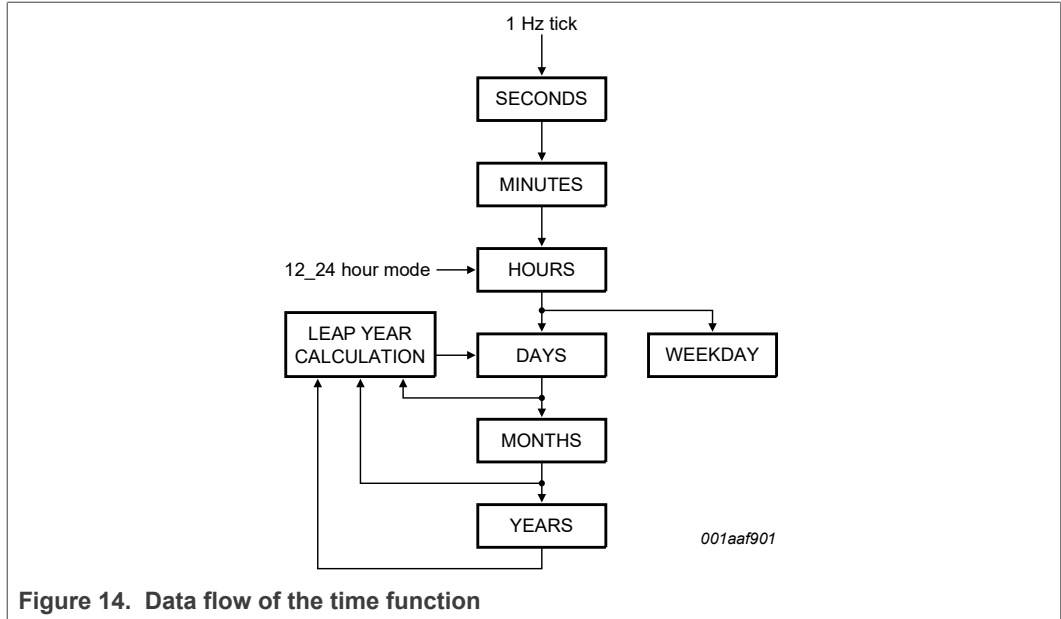

Figure 14. Data flow of the time function

After this read/write access is completed, the time circuit is released again. Any pending request to increment the time counters that occurred during the read/write access is serviced. A maximum of 1 request can be stored; therefore, all accesses must be completed within 1 second (see Figure 15).

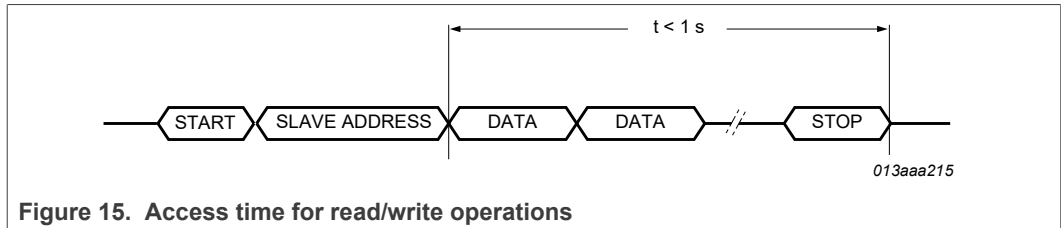

Figure 15. Access time for read/write operations

As a consequence of this method, it is very important to make a read or write access in one go. That is, setting or reading seconds through to years should be made in one single access. Failing to comply with this method could result in the time becoming corrupted.

As an example, if the time (seconds through to hours) is set in one access and then in a second access the date is set, it is possible that the time may increment between the two accesses. A similar problem exists when reading. A roll-over may occur between reads thus giving the minutes from one moment and the hours from the next. Therefore it is advised to read all time and date registers in one access.

7.9 Alarm function

When one or more of the alarm bit fields are loaded with a valid second, minute, hour, day, or weekday and its corresponding alarm enable bit (AE_x) is logic 0, then that information is compared with the actual second, minute, hour, day, and weekday (see Figure 16).

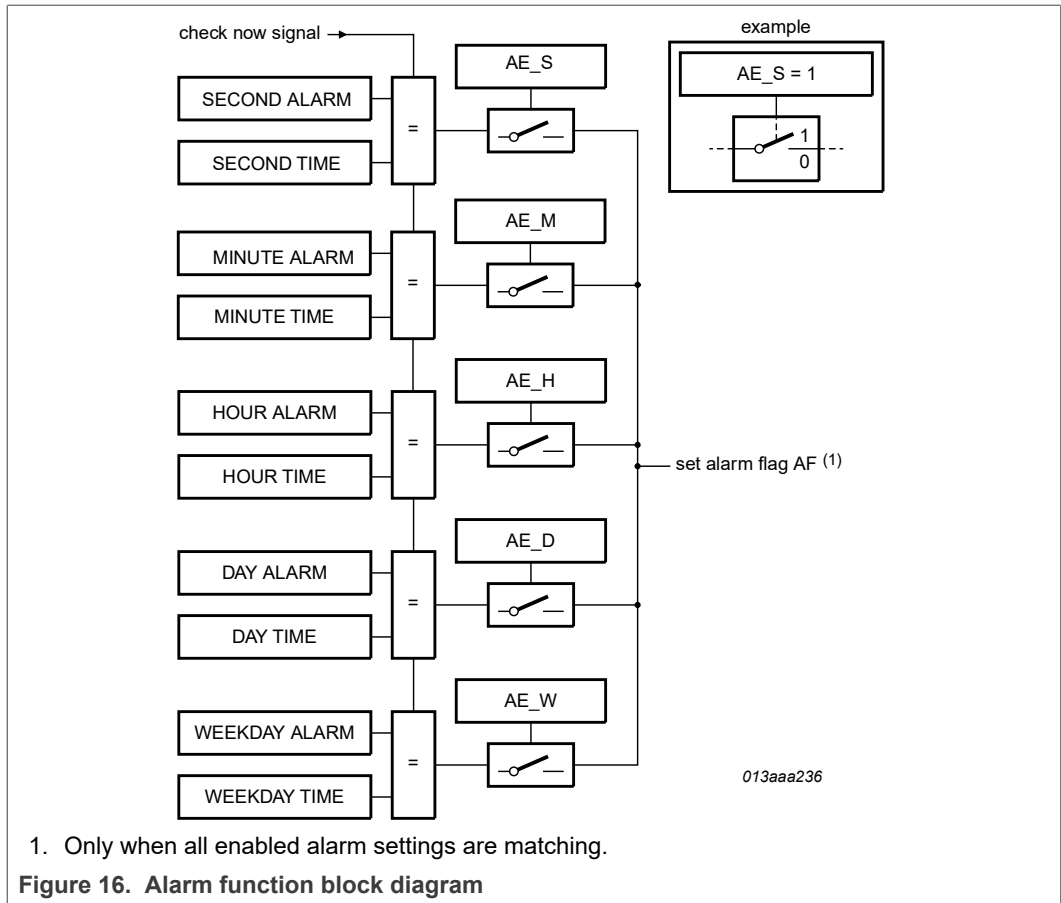

The generation of interrupts from the alarm function is described in [Section 7.12.4](#).

7.9.1 Register Second_alarm

Table 37. Second_alarm - second alarm register (address 0Ah) bit allocation
 Bits labeled as X are undefined at power-on and unchanged by subsequent resets.

Bit	7	6	5	4	3	2	1	0
Symbol	AE_S	SECOND_ALARM (0 to 59)						
Reset value	1	X	X	X	X	X	X	X

Table 38. Second_alarm - second alarm register (address 0Ah) bit description

Bit	Symbol	Value	Place value	Description
7	AE_S	0	-	second alarm is enabled
		1	-	second alarm is disabled
6 to 4	SECOND_ALARM	0 to 5	ten's place	second alarm information coded in BCD format
3 to 0		0 to 9	unit place	

7.9.2 Register Minute_alarm

Table 39. Minute_alarm - minute alarm register (address 0Bh) bit allocation

Bits labeled as X are undefined at power-on and unchanged by subsequent resets.

Bit	7	6	5	4	3	2	1	0
Symbol	AE_M	MINUTE_ALARM (0 to 59)						
Reset value	1	X	X	X	X	X	X	X

Table 40. Minute_alarm - minute alarm register (address 0Bh) bit description

Bits labeled as X are undefined at power-on and unchanged by subsequent resets.

Bit	Symbol	Value	Place value	Description
7	AE_M	0	-	minute alarm is enabled
		1	-	minute alarm is disabled
6 to 4	MINUTE_ALARM	0 to 5	ten's place	minute alarm information coded in BCD format
3 to 0		0 to 9	unit place	

7.9.3 Register Hour_alarm

Table 41. Hour_alarm - hour alarm register (address 0Ch) bit allocation

Bit positions labeled as - are not implemented and return 0 when read. Bits labeled as X are undefined at power-on and unchanged by subsequent resets.

Bit	7	6	5	4	3	2	1	0
Symbol	AE_H	-	AMPM	HOUR_ALARM (1 to 12) in 12-hour mode				
				HOUR_ALARM (0 to 23) in 24-hour mode				
Reset value	1	-	X	X	X	X	X	X

Table 42. Hour_alarm - hour alarm register (address 0Ch) bit description

Bit positions labeled as - are not implemented and return 0 when read. Bits labeled as X are undefined at power-on and unchanged by subsequent resets.

Bit	Symbol	Value	Place value	Description
7	AE_H	0	-	hour alarm is enabled
		1	-	hour alarm is disabled
6	-	-	-	unused
12-hour mode^[1]				
5	AMPM	0	-	indicates AM
		1	-	indicates PM
4	HOUR_ALARM	0 to 1	ten's place	hour alarm information coded in BCD format when in 12-hour mode
3 to 0		0 to 9	unit place	
24-hour mode^[1]				

Table 42. Hour_alarm - hour alarm register (address 0Ch) bit description...continued

Bit positions labeled as - are not implemented and return 0 when read. Bits labeled as X are undefined at power-on and unchanged by subsequent resets.

Bit	Symbol	Value	Place value	Description
5 to 4	HOUR_ALARM	0 to 2	ten's place	hour alarm information coded in BCD format when in 24-hour mode
3 to 0		0 to 9	unit place	

[1] Hour mode is set by the bit 12_24 in register Control_1.

7.9.4 Register Day_alarm

Table 43. Day_alarm - day alarm register (address 0Dh) bit allocation

Bit positions labeled as - are not implemented and return 0 when read. Bits labeled as X are undefined at power-on and unchanged by subsequent resets.

Bit	7	6	5	4	3	2	1	0
Symbol	AE_D	-	DAY_ALARM (1 to 31)					
Reset value	1	-	X	X	X	X	X	X

Table 44. Day_alarm - day alarm register (address 0Dh) bit description

Bit positions labeled as - are not implemented and return 0 when read. Bits labeled as X are undefined at power-on and unchanged by subsequent resets.

Bit	Symbol	Value	Place value	Description
7	AE_D	0	-	day alarm is enabled
		1	-	day alarm is disabled
6	-	-	-	unused
5 to 4	DAY_ALARM	0 to 3	ten's place	day alarm information coded in BCD format
3 to 0		0 to 9	unit place	

7.9.5 Register Weekday_alarm

Table 45. Weekday_alarm - weekday alarm register (address 0Eh) bit allocation

Bit positions labeled as - are not implemented and return 0 when read. Bits labeled as X are undefined at power-on and unchanged by subsequent resets.

Bit	7	6	5	4	3	2	1	0
Symbol	AE_W	-	-	-	-	WEEKDAY_ALARM (0 to 6)		
Reset value	1	-	-	-	-	X	X	X

Table 46. Weekday_alarm - weekday alarm register (address 0Eh) bit description

Bit positions labeled as - are not implemented and return 0 when read. Bits labeled as X are undefined at power-on and unchanged by subsequent resets.

Bit	Symbol	Value	Description
7	AE_W	0	weekday alarm is enabled
		1	weekday alarm is disabled
6 to 3	-	-	unused
2 to 0	WEEKDAY_ALARM	0 to 6	weekday alarm information

7.9.6 Alarm flag

When all enabled comparisons first match, the alarm flag AF (register Control_2) is set. AF remains set until cleared by command. Once AF has been cleared, it will only be set again when the time increments to match the alarm condition once more. For clearing the flags, see [Section 7.10.5](#)

Alarm registers which have their alarm enable bit AE_x at logic 1 are ignored.

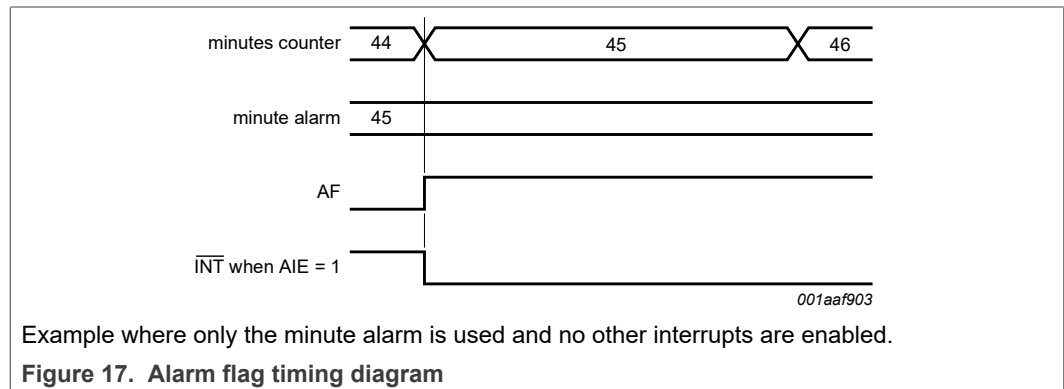

7.10 Timer functions

The PCA2129 has a watchdog timer function. The timer can be switched on and off by using the control bit WD_CD in the register Watchdog_tim_ctl.

The watchdog timer has four selectable source clocks. It can, for example, be used to detect a microcontroller with interrupt and reset capability which is out of control (see [Section 7.10.3](#))

To control the timer function and timer output, the registers Control_2, Watchdog_tim_ctl, and Watchdog_tim_val are used.

7.10.1 Register Watchdog_tim_ctl

Table 47. Watchdog_tim_ctl - watchdog timer control register (address 10h) bit allocation

Bit positions labeled as - are not implemented and return 0 when read. Bits labeled as T must always be written with logic 0.

Bit	7	6	5	4	3	2	1	0
Symbol	WD_CD	T	TI_TP	-	-	-	TF[1:0]	
Reset value	0	0	0	-	-	-	1	1

Table 48. Watchdog_tim_ctl - watchdog timer control register (address 10h) bit description

Bit positions labeled as - are not implemented and return 0 when read. Bits labeled as T must always be written with logic 0.

Bit	Symbol	Value	Description
7	WD_CD	0	watchdog timer disabled
		1	watchdog timer enabled; the interrupt pin $\overline{\text{INT}}$ is activated when timed out
6	T	0	unused
5	TI_TP	0	the interrupt pin $\overline{\text{INT}}$ is configured to generate a permanent active signal when MSF is set
		1	the interrupt pin $\overline{\text{INT}}$ is configured to generate a pulsed signal when MSF flag is set (see Figure 20)
4 to 2	-	-	unused
1 to 0	TF[1:0]		timer source clock for watchdog timer
		00	4.096 kHz
		01	64 Hz
		10	1 Hz
		11	$\frac{1}{60}$ Hz

7.10.2 Register Watchdog_tim_val

Table 49. Watchdog_tim_val - watchdog timer value register (address 11h) bit allocation

Bits labeled as X are undefined at power-on and unchanged by subsequent resets.

Bit	7	6	5	4	3	2	1	0
Symbol	WATCHDOG_TIM_VAL[7:0]							
Reset value	X	X	X	X	X	X	X	X

Table 50. Watchdog_tim_val - watchdog timer value register (address 11h) bit description

Bits labeled as X are undefined at power-on and unchanged by subsequent resets.

Bit	Symbol	Value	Description
7 to 0	WATCHDOG_TIM_VAL[7:0]	00 to FF	timer period in seconds: $TimerPeriod = \frac{n}{SourceClockFrequency}$ where n is the timer value

Table 51. Programmable watchdog timer

TF[1:0]	Timer source clock frequency	Units	Minimum timer period (n = 1)	Units	Maximum timer period (n = 255)	Units
00	4.096	kHz	244	μ s	62.256	ms
01	64	Hz	15.625	ms	3.984	s
10	1	Hz	1	s	255	s

Table 51. Programmable watchdog timer...continued

TF[1:0]	Timer source clock frequency	Units	Minimum timer period (n = 1)	Units	Maximum timer period (n = 255)	Units
11	1/60	Hz	60	s	15 300	s

7.10.3 Watchdog timer function

The watchdog timer function is enabled or disabled by the WD_CD bit of the register Watchdog_tim_ctl (see Table 48).

The 2 bits TF[1:0] in register Watchdog_tim_ctl determine one of the four source clock frequencies for the watchdog timer: 4.096 kHz, 64 Hz, 1 Hz, or 1/60 Hz (see Table 51).

When the watchdog timer function is enabled, the 8-bit timer in register Watchdog_tim_val determines the watchdog timer period (see Table 51).

The watchdog timer counts down from the software programmed 8-bit binary value n in register Watchdog_tim_val. When the counter reaches 1, the watchdog timer flag WDTF (register Control_2) is set logic 1 and an interrupt is generated.

The counter does not automatically reload.

When WD_CD is logic 0 (watchdog timer disabled) and the Microcontroller Unit (MCU) loads a watchdog timer value n:

- the flag WDTF is reset
- \overline{INT} is cleared
- the watchdog timer starts again

Loading the counter with 0 will:

- reset the flag WDTF
- clear \overline{INT}
- stop the watchdog timer

Remark: WDTF is read only and cannot be cleared by command. WDTF can be cleared by:

- loading a value in register Watchdog_tim_val
- reading of the register Control_2

Writing a logic 0 or logic 1 to WDTF has no effect.

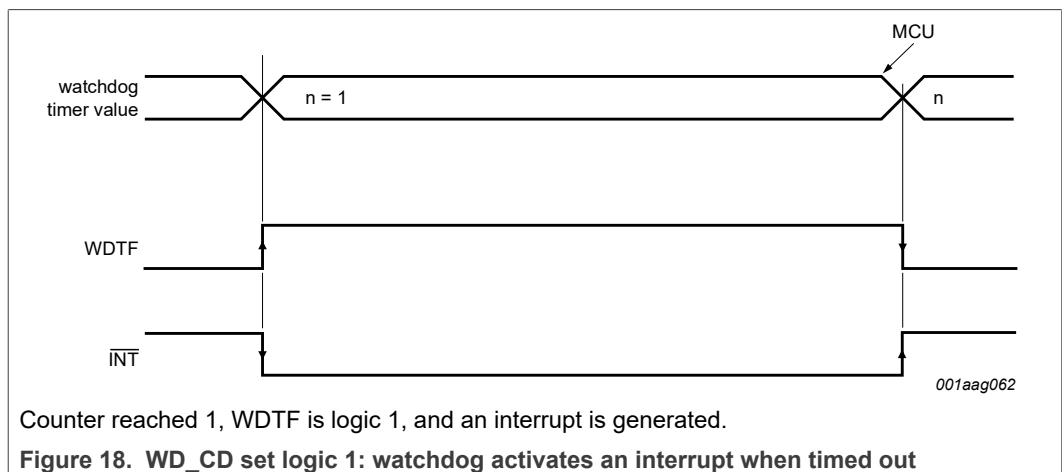

- When the watchdog timer counter reaches 1, the watchdog timer flag WDTF is set logic 1
- When a minute or second interrupt occurs, the minute/second flag MSF is set logic 1 (see [Section 7.12.1](#)).

7.10.4 Pre-defined timers: second and minute interrupt

PCA2129 has two pre-defined timers which are used to generate an interrupt either once per second or once per minute (see [Section 7.12.1](#)). The pulse generator for the minute or second interrupt operates from an internal 64 Hz clock. It is independent of the watchdog timer. Each of these timers can be enabled by the bits SI (second interrupt) and MI (minute interrupt) in register Control_1.

7.10.5 Clearing flags

The flags MSF, AF, and TSF_x can be cleared by command. To prevent one flag being overwritten while clearing another, a logic AND is performed during the write access. A flag is cleared by writing logic 0 while a flag is not cleared by writing logic 1. Writing logic 1 results in the flag value remaining unchanged.

Two examples are given for clearing the flags. Clearing a flag is made by a write command:

- Bits labeled with - must be written with their previous values
- Bits labeled with T have to be written with logic 0
- WDTF is read only and has to be written with logic 0

Repeatedly rewriting these bits has no influence on the functional behavior.

Table 52. Flag location in register Control_2

Register	Bit							
	7	6	5	4	3	2	1	0
Control_2	MSF	WDTF	TSF2	AF	T	-	-	T

Table 53. Example values in register Control_2

Register	Bit							
	7	6	5	4	3	2	1	0
Control_2	1	0	1	1	0	0	0	0

The following tables show what instruction must be sent to clear the appropriate flag.

Table 54. Example to clear only AF (bit 4)

Register	Bit							
	7	6	5	4	3	2	1	0
Control_2	1	0	1	0	0	0 ^[1]	0 ^[1]	0

[1] The bits labeled as - have to be rewritten with the previous values.

Table 55. Example to clear only MSF (bit 7)

Register	Bit							
	7	6	5	4	3	2	1	0
Control_2	0	0	1	1	0	0 ^[1]	0 ^[1]	0

[1] The bits labeled as - have to be rewritten with the previous values.

7.11 Timestamp function

The PCA2129 has an active LOW timestamp input pin \overline{TS} , internally pulled with an on-chip pull-up resistor to $V_{oper(int)}$. It also has a timestamp detection circuit which can detect two different events:

1. Input on pin \overline{TS} is driven to an intermediate level between power supply and ground.
2. Input on pin \overline{TS} is driven to ground.

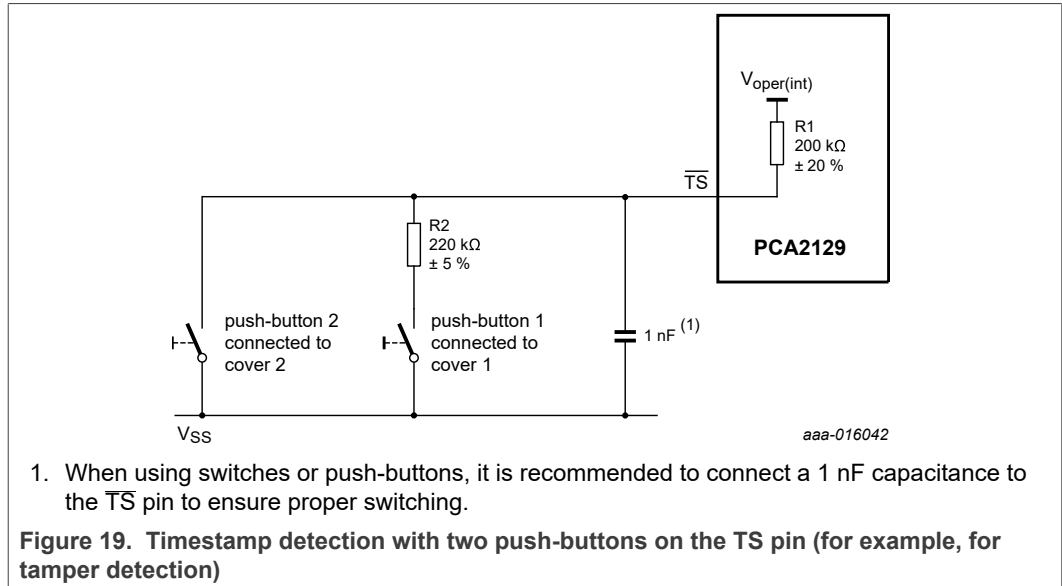

The timestamp function is enabled by default after power-on and it can be switched off by setting the control bit TSOFF (register Timestp_ctl).

A most common application of the timestamp function is described in [1].

See Section 7.12.5 for a description of interrupt generation from the timestamp function.

7.11.1 Timestamp flag

1. When the \overline{TS} input pin is driven to an intermediate level between the power supply and ground, either on the falling edge from V_{DD} or on the rising edge from ground, then the following sequence occurs:
2. The actual date and time are stored in the timestamp registers.
3. The timestamp flag TSF1 (register Control_1) is set.
4. If the TSIE bit (register Control_2) is active, an interrupt on the \overline{INT} pin is generated.

The TSF1 flag can be cleared by command. Clearing the flag clears the interrupt. Once TSF1 is cleared, it will only be set again when a new negative or positive edge on pin \overline{TS} is detected.

1. When the \overline{TS} input pin is driven to ground, the following sequence occurs:
2. The actual date and time are stored in the timestamp registers.
3. In addition to the TSF1 flag, the TSF2 flag (register Control_2) is set.
4. If the TSIE bit is active, an interrupt on the \overline{INT} pin is generated.

The TSF1 and TSF2 flags can be cleared by command; clearing both flags clears the interrupt. Once TSF2 is cleared, it will only be set again when \overline{TS} pin is driven to ground once again.

7.11.2 Timestamp mode

The timestamp function has two different modes selected by the control bit TSM (timestamp mode) in register Timestp_ctl:

- If TSM is logic 0 (default): in subsequent trigger events without clearing the timestamp flags, the last timestamp event is stored
- If TSM is logic 1: in subsequent trigger events without clearing the timestamp flags, the first timestamp event is stored

The timestamp function also depends on the control bit BTSE in register Control_3, see [Section 7.11.4](#).

7.11.3 Timestamp registers

7.11.3.1 Register Timestp_ctl

Table 56. Timestp_ctl - timestamp control register (address 12h) bit allocation

Bit positions labeled as - are not implemented and return 0 when read. Bits labeled as X are undefined at power-on and unchanged by subsequent resets.

Bit	7	6	5	4	3	2	1	0
Symbol	TSM	TSOFF	-	1_O_16_TIMESTAMP[4:0]				
Reset value	0	0	-	X	X	X	X	X

Table 57. Timestp_ctl - timestamp control register (address 12h) bit description

Bit positions labeled as - are not implemented and return 0 when read. Bits labeled as X are undefined at power-on and unchanged by subsequent resets.

Bit	Symbol	Value	Description
7	TSM	0	in subsequent events without clearing the timestamp flags, the last event is stored
		1	in subsequent events without clearing the timestamp flags, the first event is stored
6	TSOFF	0	timestamp function active
		1	timestamp function disabled
5	-	-	unused
4 to 0	1_O_16_TIMESTAMP[4:0]		$\frac{1}{16}$ second timestamp information coded in BCD format

7.11.3.2 Register Sec_timestp

Table 58. Sec_timestp - second timestamp register (address 13h) bit allocation

Bit positions labeled as - are not implemented and return 0 when read. Bits labeled as X are undefined at power-on and unchanged by subsequent resets.

Bit	7	6	5	4	3	2	1	0
Symbol	-	SECOND_TIMESTP (0 to 59)						
Reset value	-	X	X	X	X	X	X	X

Table 59. Sec_timestp - second timestamp register (address 13h) bit description

Bit positions labeled as - are not implemented and return 0 when read. Bits labeled as X are undefined at power-on and unchanged by subsequent resets.

Bit	Symbol	Value	Place value	Description
7	-	-	-	unused
6 to 4	SECOND_TIMESTP	0 to 5	ten's place	second timestamp information coded in BCD format
3 to 0		0 to 9	unit place	

7.11.3.3 Register Min_timestp

Table 60. Min_timestp - minute timestamp register (address 14h) bit allocation

Bit positions labeled as - are not implemented and return 0 when read. Bits labeled as X are undefined at power-on and unchanged by subsequent resets.

Bit	7	6	5	4	3	2	1	0
Symbol	-	MINUTE_TIMESTP (0 to 59)						
Reset value	-	X	X	X	X	X	X	X

Table 61. Min_timestp - minute timestamp register (address 14h) bit description

Bit positions labeled as - are not implemented and return 0 when read. Bits labeled as X are undefined at power-on and unchanged by subsequent resets.

Bit	Symbol	Value	Place value	Description
7	-	-	-	unused
6 to 4	MINUTE_TIMESTP	0 to 5	ten's place	minute timestamp information coded in BCD format
3 to 0		0 to 9	unit place	

7.11.3.4 Register Hour_timestp

Table 62. Hour_timestp - hour timestamp register (address 15h) bit allocation

Bit positions labeled as - are not implemented and return 0 when read. Bits labeled as X are undefined at power-on and unchanged by subsequent resets.

Bit	7	6	5	4	3	2	1	0
Symbol	-	-	AMPM	HOUR_TIMESTP (1 to 12) in 12-hour mode HOUR_TIMESTP (0 to 23) in 24-hour mode				

Table 62. Hour_timestp - hour timestamp register (address 15h) bit allocation...continued

Bit positions labeled as - are not implemented and return 0 when read. Bits labeled as X are undefined at power-on and unchanged by subsequent resets.

Bit	7	6	5	4	3	2	1	0
Reset value	-	-	X	X	X	X	X	X

Table 63. Hour_timestp - hour timestamp register (address 15h) bit description

Bit positions labeled as - are not implemented and return 0 when read. Bits labeled as X are undefined at power-on and unchanged by subsequent resets.

Bit	Symbol	Value	Place value	Description
7 to 6	-	-	-	unused
12-hour mode^[1]				
5	AMPM	0	-	indicates AM
		1	-	indicates PM
4	HOUR_TIMESTP	0 to 1	ten's place	hour timestamp information coded in BCD format when in 12-hour mode
3 to 0		0 to 9	unit place	
24-hour mode^[1]				
5 to 4	HOUR_TIMESTP	0 to 2	ten's place	hour timestamp information coded in BCD format when in 24-hour mode
3 to 0		0 to 9	unit place	

[1] Hour mode is set by the bit 12_24 in register Control_1.

7.11.3.5 Register Day_timestp

Table 64. Day_timestp - day timestamp register (address 16h) bit allocation

Bit positions labeled as - are not implemented and return 0 when read. Bits labeled as X are undefined at power-on and unchanged by subsequent resets.

Bit	7	6	5	4	3	2	1	0
Symbol	-	-	DAY_TIMESTP (1 to 31)					
Reset value	-	-	X	X	X	X	X	X

Table 65. Day_timestp - day timestamp register (address 16h) bit description

Bit positions labeled as - are not implemented and return 0 when read. Bits labeled as X are undefined at power-on and unchanged by subsequent resets.

Bit	Symbol	Value	Place value	Description
7 to 6	-	-	-	unused
5 to 4	DAY_TIMESTP	0 to 3	ten's place	day timestamp information coded in BCD format
3 to 0		0 to 9	unit place	

7.11.3.6 Register Mon_timestp

Table 66. Mon_timestp - month timestamp register (address 17h) bit allocation

Bit positions labeled as - are not implemented and return 0 when read. Bits labeled as X are undefined at power-on and unchanged by subsequent resets.

Bit	7	6	5	4	3	2	1	0
Symbol	-	-	-	MONTH_TIMESTP (1 to 12)				
Reset value	-	-	-	X	X	X	X	X

Table 67. Mon_timestp - month timestamp register (address 17h) bit description

Bit positions labeled as - are not implemented and return 0 when read. Bits labeled as X are undefined at power-on and unchanged by subsequent resets.

Bit	Symbol	Value	Place value	Description
7 to 5	-	-	-	unused
4	MONTH_TIMESTP	0 to 1	ten's place	month timestamp information coded in BCD format
3 to 0		0 to 9	unit place	

7.11.3.7 Register Year_timestp

Table 68. Year_timestp - year timestamp register (address 18h) bit allocation

Bits labeled as X are undefined at power-on and unchanged by subsequent resets.

Bit	7	6	5	4	3	2	1	0
Symbol	YEAR_TIMESTP (0 to 99)							
Reset value	X	X	X	X	X	X	X	X

Table 69. Year_timestp - year timestamp register (address 18h) bit description

Bits labeled as X are undefined at power-on and unchanged by subsequent resets.

Bit	Symbol	Value	Place value	Description
7 to 4	YEAR_TIMESTP	0 to 9	ten's place	year timestamp information coded in BCD format
3 to 0		0 to 9	unit place	

7.11.4 Dependency between Battery switch-over and timestamp

The timestamp function depends on the control bit BTSE in register Control-_3:

Table 70. Battery switch-over and timestamp

BTSE	BF	Description
0	-	^[1] the battery switch-over does not affect the timestamp registers
1		If a battery switch-over event occurs:

Table 70. Battery switch-over and timestamp...continued

BTSE	BF		Description
	0	[1]	the timestamp registers store the time and date when the switch-over occurs; after this event occurred BF is set logic 1
	1		the timestamp registers are not modified; in this condition subsequent battery switch-over events or falling edges on pin \overline{TS} are not registered

[1] Default value.

7.12 Interrupt output, INT

PCA2129 has an interrupt output pin \overline{INT} which is open-drain, active LOW (requiring a pull-up resistor if used). Interrupts may be sourced from different places:

- second or minute timer
- watchdog timer
- alarm
- timestamp
- battery switch-over
- battery low detection

The control bit TI_TP (register Watchdg_tim_ctl) is used to configure whether the interrupts generated from the second/minute timer (flag MSF in register Control_2) are pulsed signals or a permanently active signal. All the other interrupt sources generate a permanently active interrupt signal which follows the status of the corresponding flags. When the interrupt sources are all disabled, \overline{INT} remains high-impedance.

- The flags MSF, AF, TSF_x, and BF can be cleared by command.
- The flag WDTF is read only. How it can be cleared is explained in [Section 7.10.5](#).
- The flag BLF is read only. It is cleared automatically from the battery low detection circuit when the battery is replaced.

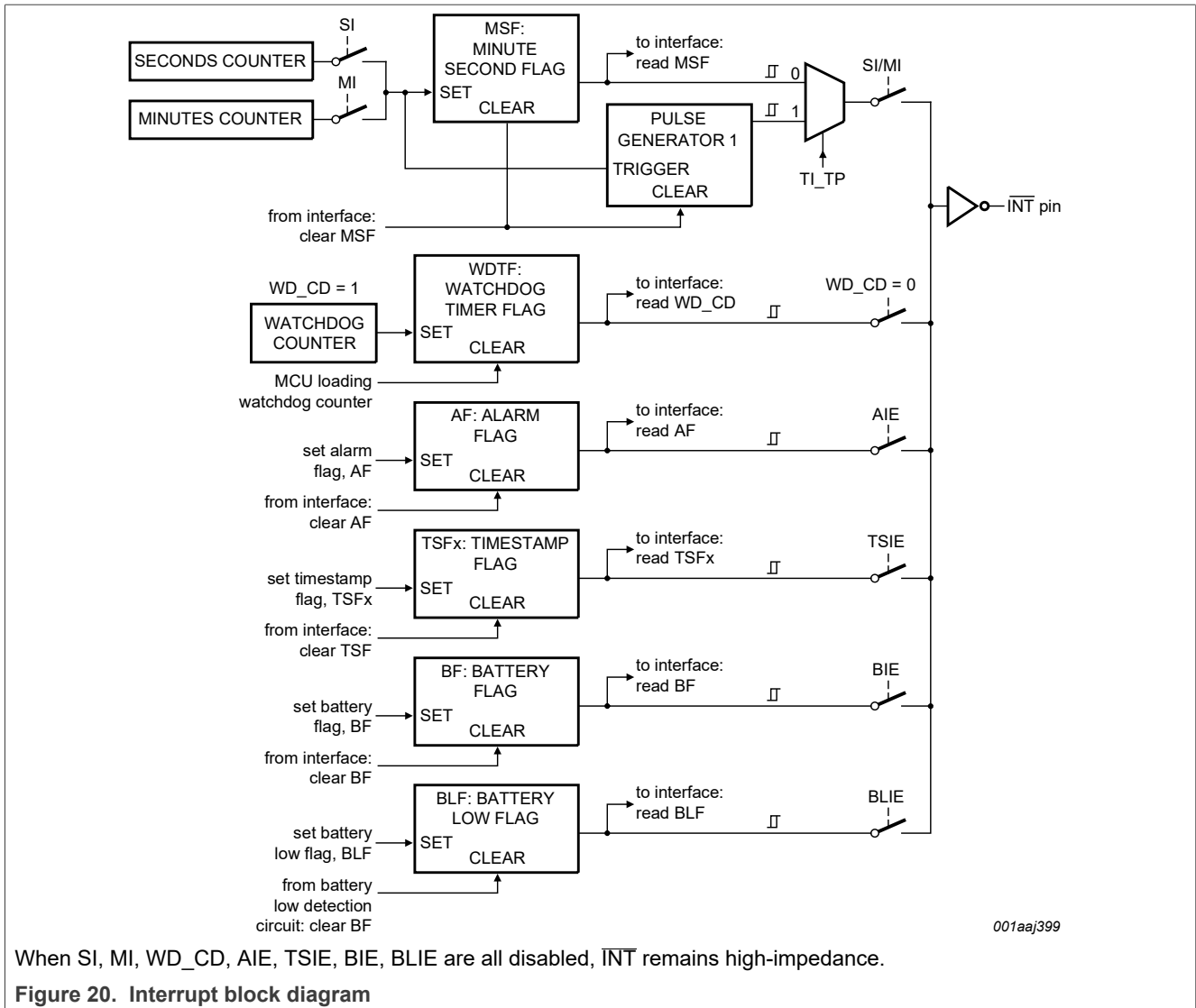

Figure 20. Interrupt block diagram

7.12.1 Minute and second interrupts

Minute and second interrupts are generated by predefined timers. The timers can be enabled independently from one another by the bits MI and SI in register Control_1. However, a minute interrupt enabled on top of a second interrupt cannot be distinguishable since it occurs at the same time.

The minute/second flag MSF (register Control_2) is set logic 1 when either the seconds or the minutes counter increments according to the enabled interrupt (see Table 71). The MSF flag can be cleared by command.

Table 71. Effect of bits MI and SI on pin \overline{INT} and bit MSF

MI	SI	Result on \overline{INT}	Result on MSF
0	0	no interrupt generated	MSF never set
1	0	an interrupt once per minute	MSF set when minutes counter increments

Table 71. Effect of bits MI and SI on pin INT and bit MSF...continued

MI	SI	Result on INT	Result on MSF
0	1	an interrupt once per second	MSF set when seconds counter increments
1	1	an interrupt once per second	MSF set when seconds counter increments

When MSF is set logic 1:

- If TI_TP is logic 1, the interrupt is generated as a pulsed signal.
- If TI_TP is logic 0, the interrupt is permanently active signal that remains until MSF is cleared.

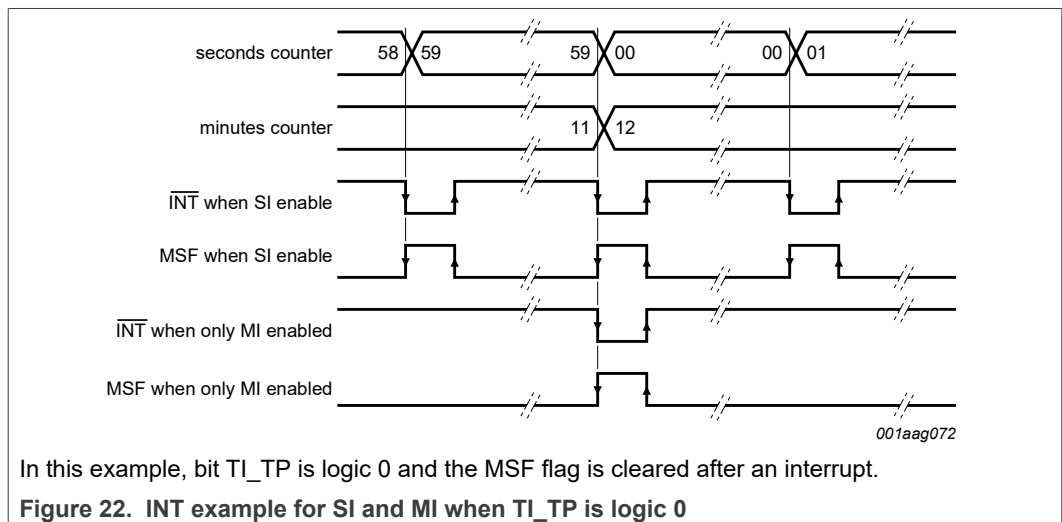
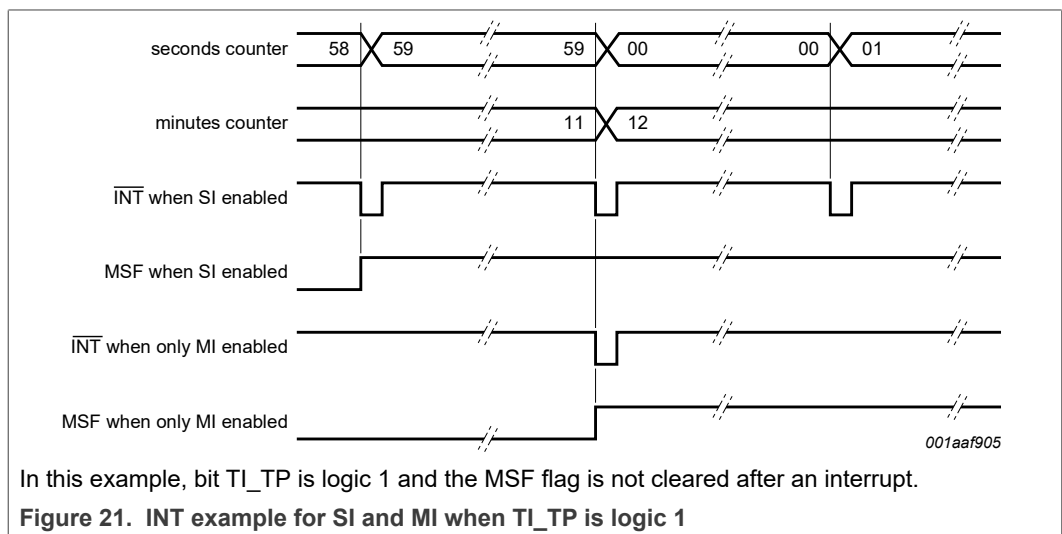

The pulse generator for the minute/second interrupt operates from an internal 64 Hz clock and generates a pulse of $\frac{1}{64}$ seconds in duration.

7.12.2 INT pulse shortening

If the MSF flag (register Control_2) is cleared before the end of the $\overline{\text{INT}}$ pulse, then the $\overline{\text{INT}}$ pulse is shortened. This allows the source of a system interrupt to be cleared immediately when it is serviced, that is, the system does not have to wait for the completion of the pulse before continuing; see [Figure 23](#). Instructions for clearing the bit MSF can be found in [Section 7.10.5](#).

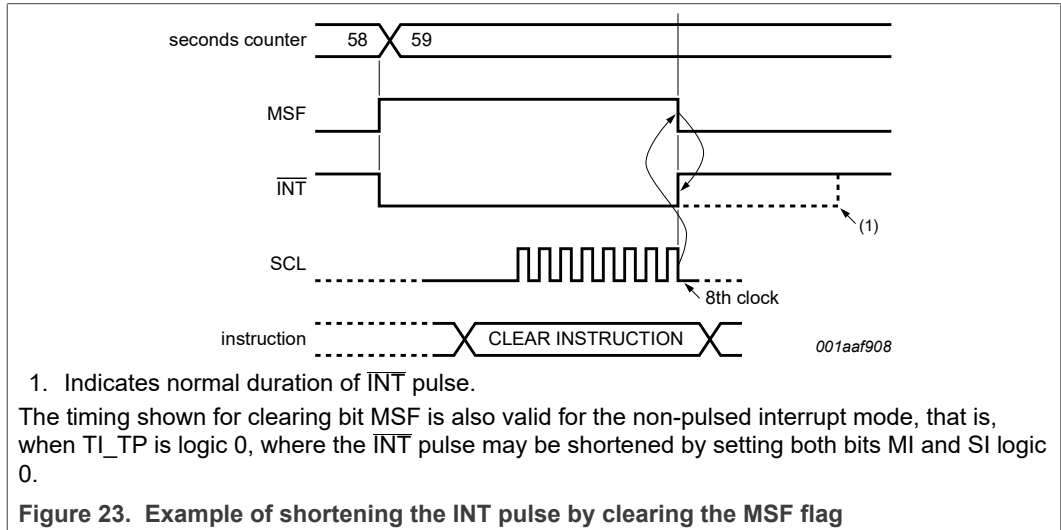

7.12.3 Watchdog timer interrupts

The generation of interrupts from the watchdog timer is controlled using the WD_CD bit (register Watchdg_tim_ctl). The interrupt is generated as an active signal which follows the status of the watchdog timer flag WDTF (register Control_2). No pulse generation is possible for watchdog timer interrupts.

The interrupt is cleared when the flag WDTF is reset. WDTF is a read-only bit and cannot be cleared by command. Instructions for clearing it can be found in [Section 7.10.5](#).

7.12.4 Alarm interrupts

Generation of interrupts from the alarm function is controlled by the bit AIE (register Control_2). If AIE is enabled, the $\overline{\text{INT}}$ pin follows the status of bit AF (register Control_2). Clearing AF immediately clears $\overline{\text{INT}}$. No pulse generation is possible for alarm interrupts.

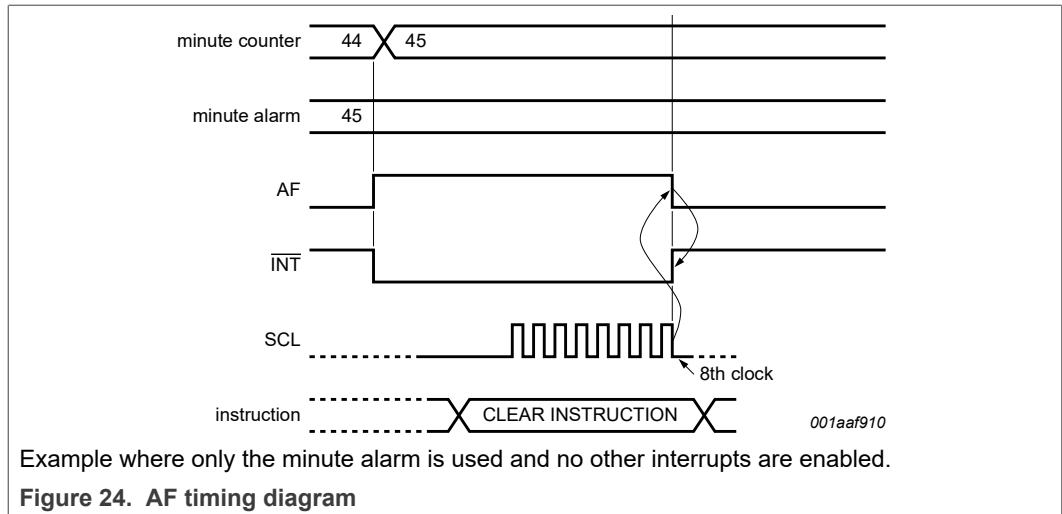

7.12.5 Timestamp interrupts

Interrupt generation from the timestamp function is controlled using the TSIE bit (register Control_2). If TSIE is enabled, the INT pin follows the status of the flags TSFx. Clearing the flags TSFx immediately clears INT. No pulse generation is possible for timestamp interrupts.

7.12.6 Battery switch-over interrupts

Generation of interrupts from the battery switch-over is controlled by the BIE bit (register Control_3). If BIE is enabled, the INT pin follows the status of bit BF in register Control_3 (see Table 70). Clearing BF immediately clears INT. No pulse generation is possible for battery switch-over interrupts.

7.12.7 Battery low detection interrupts

Generation of interrupts from the battery low detection is controlled by the BLIE bit (register Control_3). If BLIE is enabled, the INT pin follows the status of bit BLF (register Control_3). The interrupt is cleared when the battery is replaced (BLF is logic 0) or when bit BLIE is disabled (BLIE is logic 0). BLF is read only and therefore cannot be cleared by command.

7.13 External clock test mode

A test mode is available which allows on-board testing. In this mode, it is possible to set up test conditions and control the operation of the RTC.

The test mode is entered by setting bit EXT_TEST logic 1 (register Control_1). Then pin CLKOUT becomes an input. The test mode replaces the internal clock signal (64 Hz) with the signal applied to pin CLKOUT. Every 64 positive edges applied to pin CLKOUT generate an increment of one second.

The signal applied to pin CLKOUT should have a minimum pulse width of 300 ns and a maximum period of 1 000 ns. The internal clock, now sourced from CLKOUT, is divided down by a 2⁶ divider chain called prescaler (see Table 72). The prescaler can be set into a known state by using bit STOP. When bit STOP is logic 1, the prescaler is reset to 0. STOP must be cleared before the prescaler can operate again.

From a stop condition, the first 1 second increment will take place after 32 positive edges on pin CLKOUT. Thereafter, every 64 positive edges cause a 1 second increment.

Remark: Entry into test mode is not synchronized to the internal 64 Hz clock. When entering the test mode, no assumption as to the state of the prescaler can be made.

Operating example:

1. Set EXT_TEST test mode (register Control_1, EXT_TEST is logic 1).
2. Set bit STOP (register Control_1, STOP is logic 1).
3. Set time registers to desired value.
4. Clear STOP (register Control_1, STOP is logic 0).
5. Apply 32 clock pulses to CLKOUT.
6. Read time registers to see the first change.
7. Apply 64 clock pulses to CLKOUT.
8. Read time registers to see the second change.

Repeat 7 and 8 for additional increments.

7.14 STOP bit function

The function of the STOP bit is to allow for accurate starting of the time circuits. STOP causes the upper part of the prescaler (F₉ to F₁₄) to be held in reset and thus no 1 Hz ticks are generated. The time circuits can then be set and will not increment until the STOP bit is released. STOP doesn't affect the CLKOUT signal but the output of the prescaler in the range of 32 Hz to 1 Hz (see [Figure 25](#)).

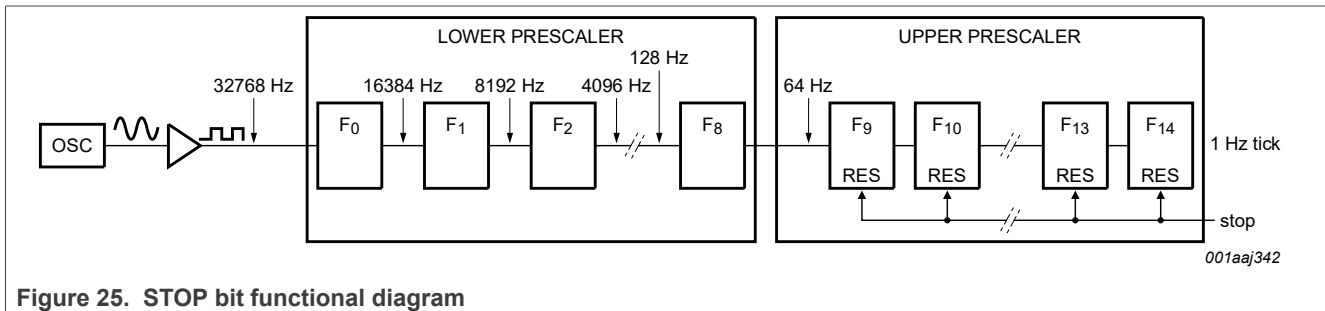

The lower stages of the prescaler, F₀ to F₈, are not reset and because the I²C-bus and the SPI-bus are asynchronous to the crystal oscillator, the accuracy of restarting the time circuits is between 0 and one 64 Hz cycle (0.484 375 s and 0.500 000 s), see [Table 72](#) and [Figure 26](#).

Table 72. First increment of time circuits after stop release

Bit STOP	Prescaler bits ^[1] F ₀ to F ₈ - F ₉ to F ₁₄	1 Hz tick	Time hh:mm:ss	Comment
Clock is running normally				
0	010000111-010100		12:45:12	prescaler counting normally
STOP bit is activated by user. F₀ to F₈ are not reset and values cannot be predicted externally				
1	xxxxxxxxx-000000		12:45:12	prescaler is reset; time circuits are frozen
New time is set by user				
1	xxxxxxxxx-000000		08:00:00	prescaler is reset; time circuits are frozen

Table 72. First increment of time circuits after stop release...continued

Bit STOP	Prescaler bits ^[1] F ₀ to F ₈ - F ₉ to F ₁₄	1 Hz tick	Time hh:mm:ss	Comment
STOP bit is released by user				
0	xxxxxxxxxx-000000		08:00:00	prescaler is now running
0	xxxxxxxxxx-100000		08:00:00	
0	xxxxxxxxxx-100000		08:00:00	
0	xxxxxxxxxx-110000		08:00:00	
:	:		:	
0	11111111-111110		08:00:00	
0	00000000-000001		08:00:01	0 to 1 transition of F ₁₄ increments the time circuits
0	10000000-000001		08:00:01	
:	:		:	
0	11111111-111111		08:00:01	
0	00000000-000000		08:00:01	
0	10000000-000000			
:	:		:	
0	11111111-111110		08:00:01	
0	00000000-000001		08:00:02	0 to 1 transition of F ₁₄ increments the time circuits

[1] F₀ is clocked at 32.768 kHz.

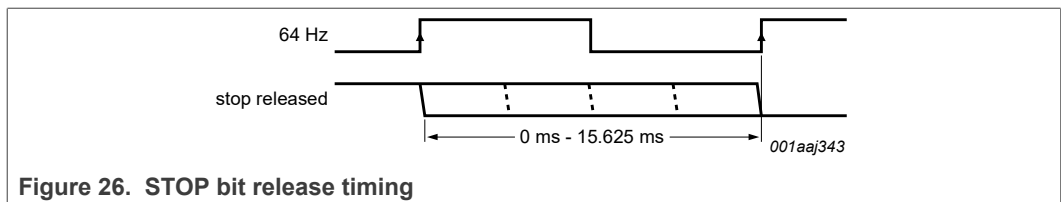

8 Interfaces

The PCA2129 has an I²C-bus or SPI-bus interface using the same pins. The selection is done using the interface selection pin IFS (see [Table 73](#)).

Table 73. Interface selection input pin IFS

Pin	Connection	Bus interface	Reference
IFS	V _{SS}	SPI-bus	Section 8.1
	BBS	I ² C-bus	Section 8.2

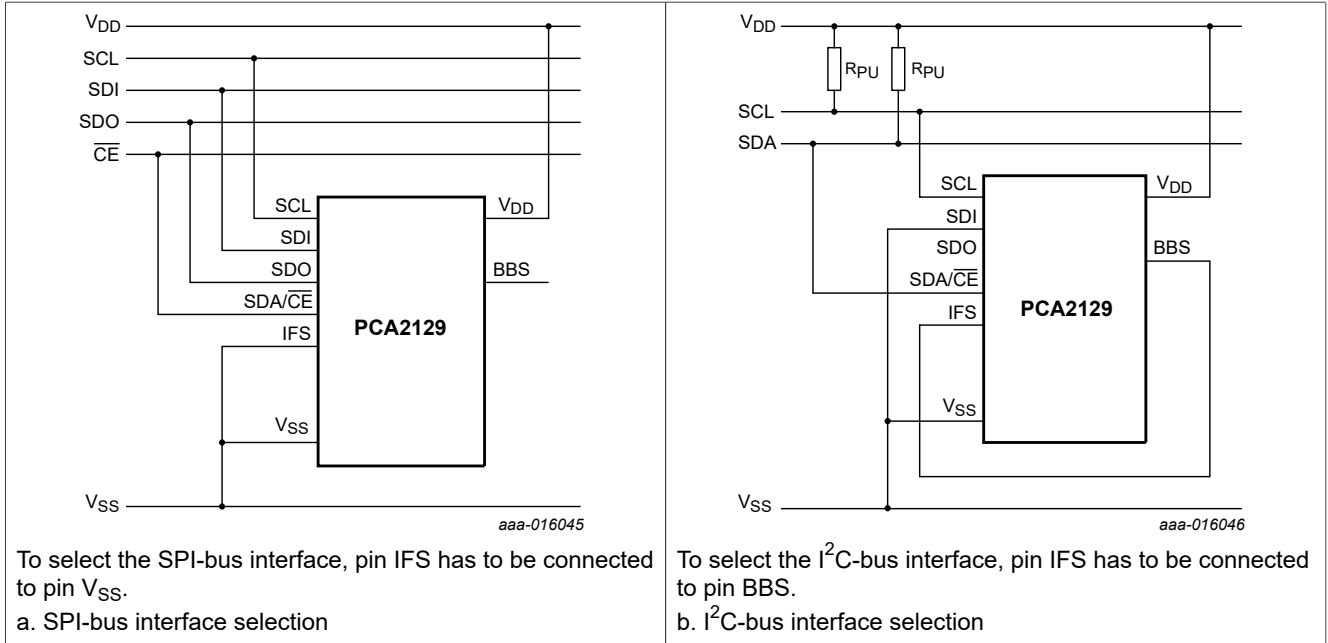

Figure 27. Interface selection

8.1 SPI-bus interface

Data transfer to and from the device is made by a 3 line SPI-bus (see Table 74). The data lines for input and output are split. The data input and output line can be connected together to facilitate a bidirectional data bus (see Figure 28). The SPI-bus is initialized whenever the chip enable line pin SDA/CE is inactive.

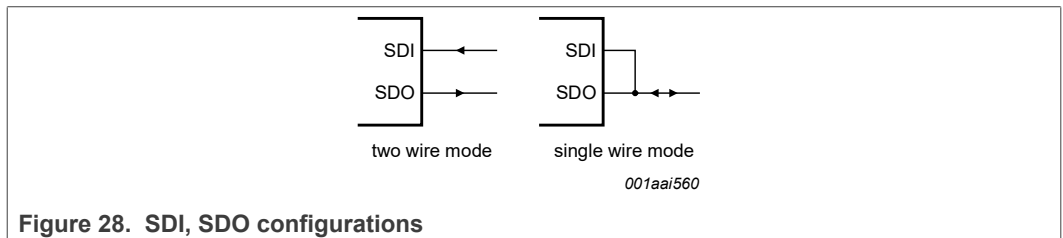

Figure 28. SDI, SDO configurations

Table 74. Serial interface

Symbol	Function	Description
SDA/CE	chip enable input; active LOW	^[1] when HIGH, the interface is reset; input may be higher than V _{DD}
SCL	serial clock input	when SDA/CE is HIGH, input may float; input may be higher than V _{DD}
SDI	serial data input	when SDA/CE is HIGH, input may float; input may be higher than V _{DD} ; input data is sampled on the rising edge of SCL

Table 74. Serial interface...continued

Symbol	Function	Description
SDO	serial data output	push-pull output; drives from V_{SS} to $V_{oper(int)}$ (V_{BBS}); output data is changed on the falling edge of SCL

[1] The chip enable must not be wired permanently LOW.

8.1.1 Data transmission

The chip enable signal is used to identify the transmitted data. Each data transfer is a whole byte, with the Most Significant Bit (MSB) sent first.

The transmission is controlled by the active LOW chip enable signal SDA/\overline{CE} . The first byte transmitted is the command byte. Subsequent bytes are either data to be written or data to be read (see [Figure 29](#)).

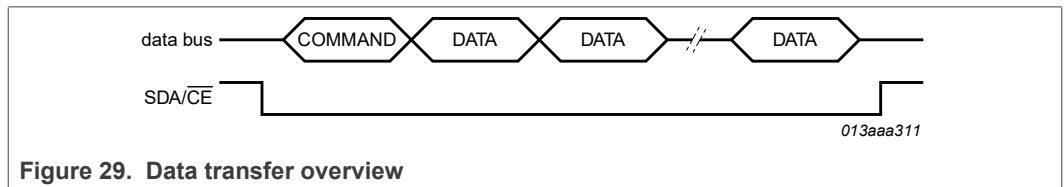
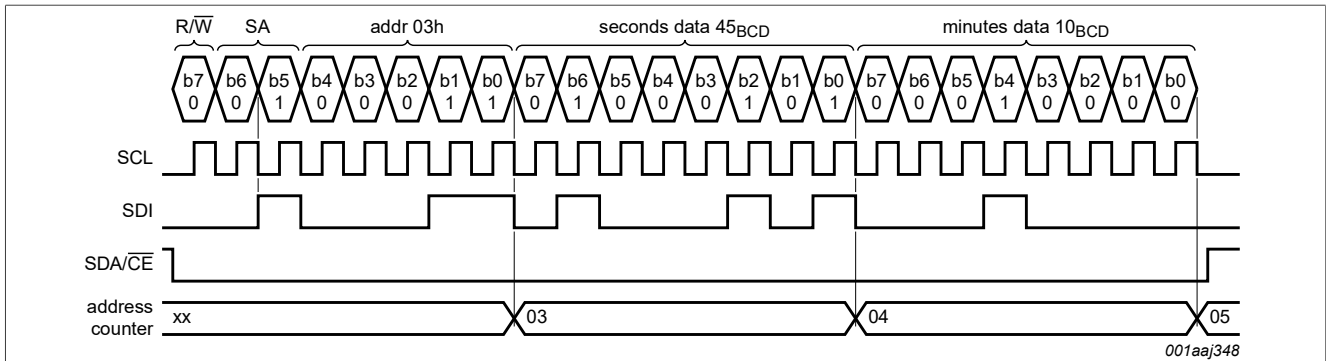

Figure 29. Data transfer overview

The command byte defines the address of the first register to be accessed and the read/write mode. The address counter will auto increment after every access and will reset to zero after the last valid register is accessed. The R/W bit defines if the following bytes are read or write information.

Table 75. Command byte definition

Bit	Symbol	Value	Description
7	R/W		data read or write selection
		0	write data
		1	read data
6 to 5	SA	01	subaddress; other codes will cause the device to ignore data transfer
4 to 0	RA	00h to 1Bh	register address



In this example, the Seconds register is set to 45 seconds and the Minutes register to 10 minutes.

Figure 30. SPI-bus write example

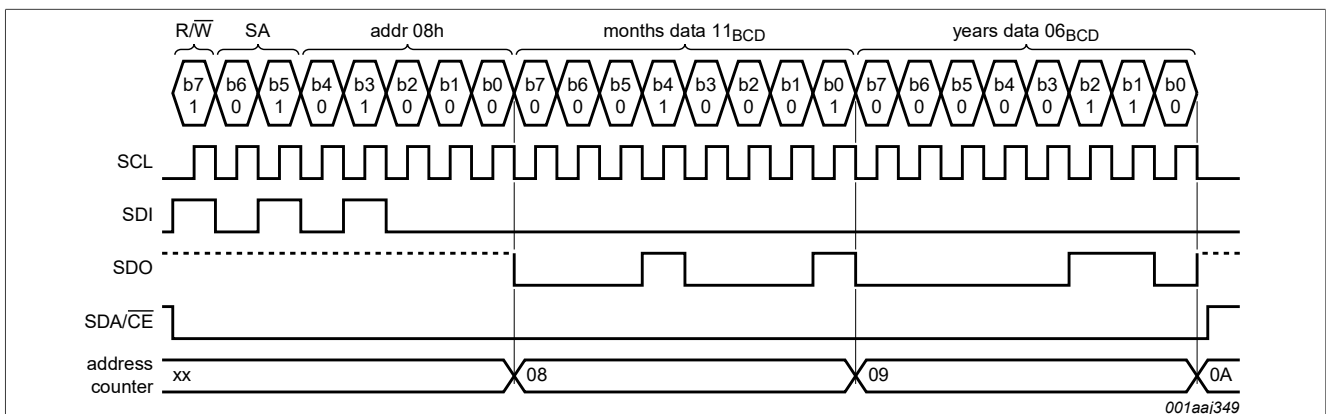

In this example, the registers Months and Years are read. The pins SDI and SDO are not connected together. For this configuration, it is important that pin SDI is never left floating. It must always be driven either HIGH or LOW. If pin SDI is left open, high I_{DD} currents may result.

Figure 31. SPI-bus read example

8.2 I²C-bus interface

The I²C-bus is for bidirectional, two-line communication between different ICs or modules. The two lines are a Serial DATA line (SDA) and a Serial CLOCK line (SCL). Both lines are connected to a positive supply by a pull-up resistor. Data transfer is initiated only when the bus is not busy.

8.2.1 Bit transfer

One data bit is transferred during each clock pulse. The data on the SDA line remains stable during the HIGH period of the clock pulse as changes in the data line at this time are interpreted as control signals (see [Figure 32](#)).

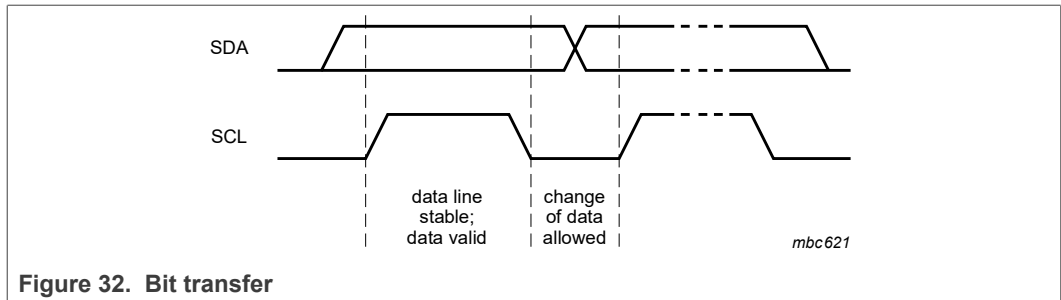

Figure 32. Bit transfer

8.2.2 START and STOP conditions

Both data and clock lines remain HIGH when the bus is not busy. A HIGH-to-LOW transition of the data line, while the clock is HIGH, is defined as the START condition S. A LOW-to-HIGH transition of the data line while the clock is HIGH is defined as the STOP condition P (see Figure 33).

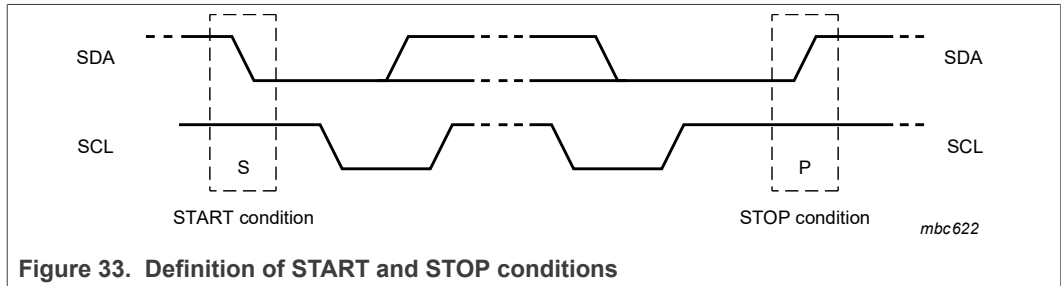

Figure 33. Definition of START and STOP conditions

Remark: For the PCA2129, a repeated START is not allowed. Therefore a STOP has to be released before the next START.

8.2.3 System configuration

A device generating a message is a transmitter; a device receiving a message is the receiver. The device that controls the message is the master; and the devices which are controlled by the master are the slaves.

The PCA2129 can act as a slave transmitter and a slave receiver.

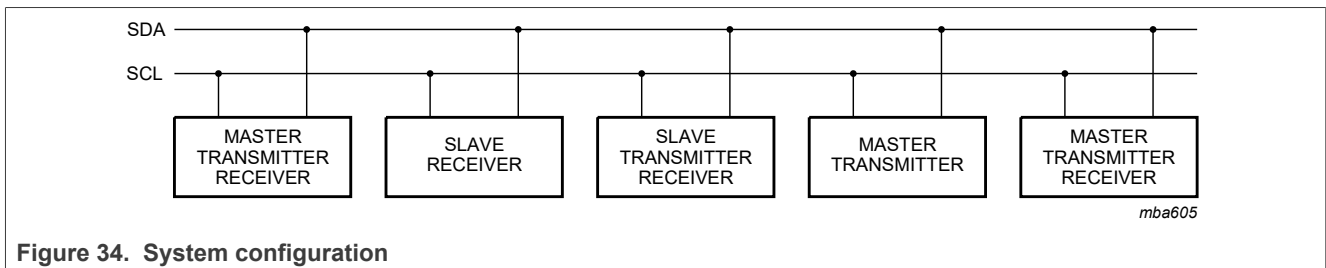

Figure 34. System configuration

8.2.4 Acknowledge

The number of data bytes transferred between the START and STOP conditions from transmitter to receiver is unlimited. Each byte of 8 bits is followed by an acknowledge cycle.

- A slave receiver which is addressed must generate an acknowledge after the reception of each byte.
- Also a master receiver must generate an acknowledge after the reception of each byte that has been clocked out of the slave transmitter.
- The device that acknowledges must pull-down the SDA line during the acknowledge clock pulse, so that the SDA line is stable LOW during the HIGH period of the acknowledge related clock pulse (set-up and hold times must be considered).
- A master receiver must signal an end of data to the transmitter by not generating an acknowledge on the last byte that has been clocked out of the slave. In this event, the transmitter must leave the data line HIGH to enable the master to generate a STOP condition.

Acknowledgement on the I²C-bus is illustrated in [Figure 35](#).

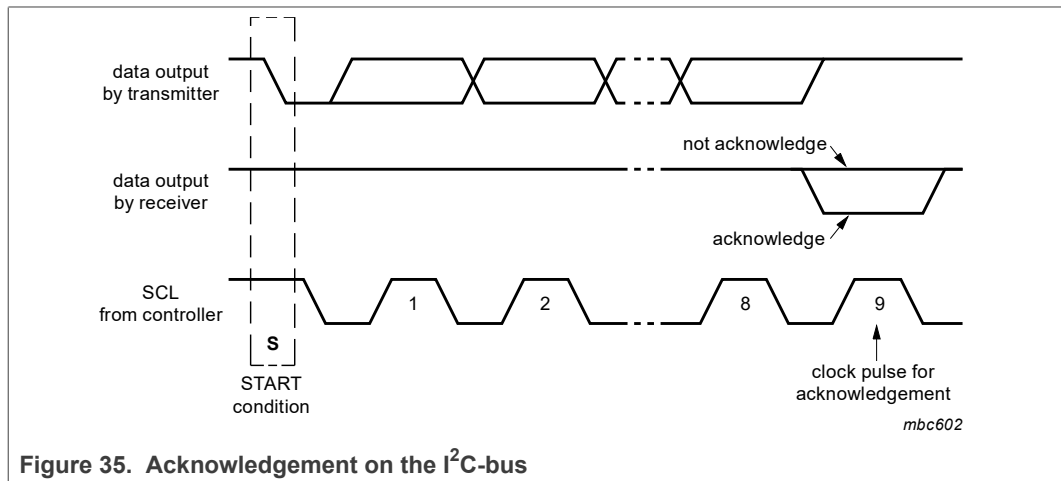

Figure 35. Acknowledgement on the I²C-bus

8.2.5 I²C-bus protocol

After a start condition, a valid hardware address has to be sent to a PCA2129 device. The appropriate I²C-bus slave address is 1010 001. The entire I²C-bus slave address byte is shown in [Table 76](#).

Table 76. I²C slave address byte

Bit	Slave address							0
	7	6	5	4	3	2	1	
	MSB							LSB
	1	0	1	0	0	0	1	R/W

The R/W bit defines the direction of the following single or multiple byte data transfer (read is logic 1, write is logic 0).

For the format and the timing of the START condition (S), the STOP condition (P), and the acknowledge (A) refer to the I²C-bus specification [6] and the characteristics table ([Table 81](#)). In the write mode, a data transfer is terminated by sending a STOP condition. A repeated START (Sr) condition is not applicable.

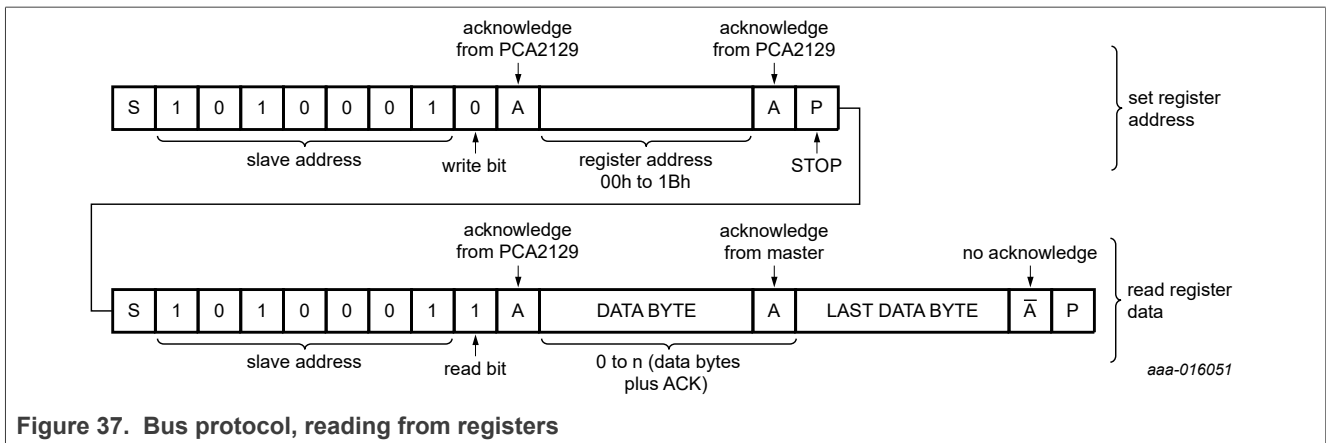
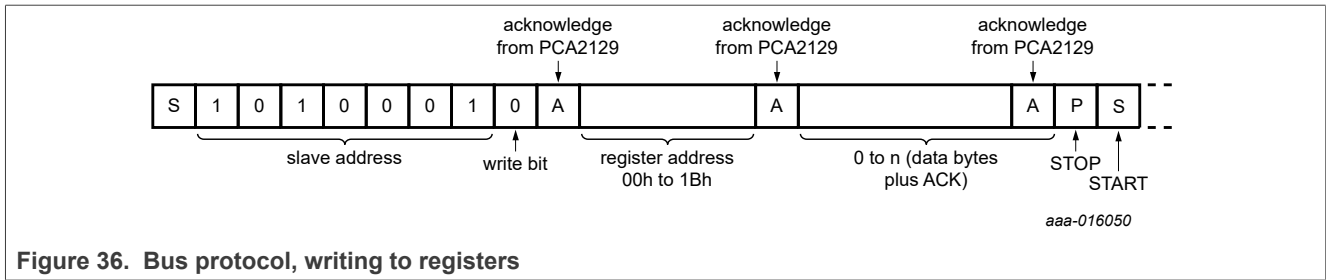

8.3 Bus communication and battery backup operation

To save power during battery backup operation (see [Section 7.5.1](#)), the bus interfaces are inactive. Therefore the communication via I²C- or SPI-bus should be terminated before the supply of the PCA2129 is switched from V_{DD} to V_{BAT}.

Remark: If the I²C-bus communication was terminated uncontrolled, the I²C-bus has to be reinitialized by sending a STOP followed by a START after the device switched back from battery backup operation to V_{DD} supply operation.

9 Internal circuitry

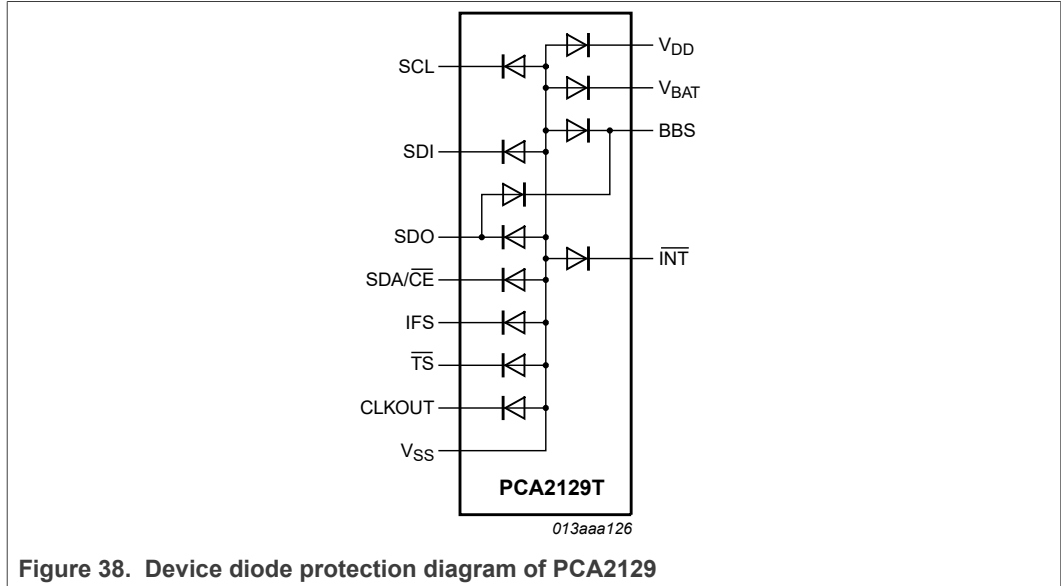



Figure 38. Device diode protection diagram of PCA2129

10 Safety notes

CAUTION



This device is sensitive to ElectroStatic Discharge (ESD). Observe precautions for handling electrostatic sensitive devices. Such precautions are described in the ANSI/ESD S20.20, IEC/ST 61340-5, JESD625-A or equivalent standards.

11 Limiting values

Table 77. Limiting values
In accordance with the Absolute Maximum Rating System (IEC 60134).

Symbol	Parameter	Conditions	Min	Max	Unit
V _{DD}	supply voltage		-0.5	+6.5	V
I _{DD}	supply current		-50	+50	mA
V _i	input voltage		-0.5	+6.5	V
I _I	input current		-10	+10	mA
V _O	output voltage		-0.5	+6.5	V
I _O	output current		-10	+10	mA
		at pin SDA/CE	-10	+20	mA
V _{BAT}	battery supply voltage		-0.5	+6.5	V
P _{tot}	total power dissipation		-	300	mW
V _{ESD}	electrostatic discharge voltage	HBM	[1] -	±4 000	V
		CDM	[2] -	±1 250	V

Table 77. Limiting values...continued

In accordance with the Absolute Maximum Rating System (IEC 60134).

Symbol	Parameter	Conditions	Min	Max	Unit
I_{lu}	latch-up current		[3] -	200	mA
T_{stg}	storage temperature		[4] -55	+85	°C
T_{amb}	ambient temperature	operating device	-40	+85	°C

[1] Pass level; Human Body Model (HBM) according to [2].

[2] Pass level; Charged-Device Model (CDM), according to [3].

[3] Pass level; latch-up testing according to [4] at maximum ambient temperature ($T_{amb(max)}$).

[4] According to the store and transport requirements (see [7]) the devices have to be stored at a temperature of +8 °C to +45 °C and a humidity of 25 % to 75 %.

12 Static characteristics

Table 78. Static characteristics

$V_{DD} = 1.8 V$ to $4.2 V$; $V_{SS} = 0 V$; $T_{amb} = -40 °C$ to $+85 °C$, unless otherwise specified.

Symbol	Parameter	Conditions	Min	Typ	Max	Unit	
Supplies							
V_{DD}	supply voltage		[1] 1.8	-	4.2	V	
V_{BAT}	battery supply voltage		1.8	-	4.2	V	
$V_{DD(cal)}$	calibration supply voltage		-	3.3	-	V	
V_{low}	low voltage		-	1.2	-	V	
I_{DD}	supply current	interface active; supplied by V_{DD}					
		SPI-bus ($f_{SCL} = 6.5 MHz$)	-	-	800	µA	
		I ² C-bus ($f_{SCL} = 400 kHz$)	-	-	200	µA	
		interface inactive ($f_{SCL} = 0 Hz$) ^[2] ; TCR[1:0] = 00 (see Table 12)					
		PWRMNG[2:0] = 111 (see Table 18); TSOFF = 1 (see Table 57); COF[2:0] = 111 (see Table 14)					
		$V_{DD} = 1.8 V$	-	470	-	nA	
		$V_{DD} = 3.3 V$	-	700	1 500	nA	
		$V_{DD} = 4.2 V$	-	800	-	nA	
		PWRMNG[2:0] = 111 (see Table 18); TSOFF = 1 (see Table 57); COF[2:0] = 000 (see Table 14)					
		$V_{DD} = 1.8 V$	-	560	-	nA	
		$V_{DD} = 3.3 V$	-	850	-	nA	
		$V_{DD} = 4.2 V$	-	1 050	-	nA	
		PWRMNG[2:0] = 000 (see Table 18); TSOFF = 0 (see Table 57); COF[2:0] = 111 (see Table 14)					

Table 78. Static characteristics...continued

$V_{DD} = 1.8\text{ V to }4.2\text{ V}$; $V_{SS} = 0\text{ V}$; $T_{amb} = -40\text{ }^{\circ}\text{C to }+85\text{ }^{\circ}\text{C}$, unless otherwise specified.

Symbol	Parameter	Conditions	Min	Typ	Max	Unit
		V_{DD} or $V_{BAT} = 1.8\text{ V}$	[3] -	1 750	-	nA
		V_{DD} or $V_{BAT} = 3.3\text{ V}$	[3] -	2 150	-	nA
		V_{DD} or $V_{BAT} = 4.2\text{ V}$	[3] -	2 350	3 500	nA
		PWRMNG[2:0] = 000 (see Table 18); TSOFF = 0 (see Table 57); COF[2:0] = 000 (see Table 14)				
		V_{DD} or $V_{BAT} = 1.8\text{ V}$	[3] -	1 840	-	nA
		V_{DD} or $V_{BAT} = 3.3\text{ V}$	[3] -	2 300	-	nA
		V_{DD} or $V_{BAT} = 4.2\text{ V}$	[3] -	2 600	-	nA
$I_{L(bat)}$	battery leakage current	V_{DD} is active supply; $V_{BAT} = 3.0\text{ V}$	-	50	100	nA
Power management						
$V_{th(sw)bat}$	battery switch threshold voltage		-	2.5	-	V
$V_{th(bat)low}$	low battery threshold voltage		-	2.5	-	V
		$T_{amb} = 25\text{ }^{\circ}\text{C}$	2.25	-	2.85	V
Inputs ^[4]						
V_I	input voltage		-0.5	-	$V_{DD} + 0.5$	V
V_{IL}	LOW-level input voltage		-	-	$0.25V_{DD}$	V
		$T_{amb} = -20\text{ }^{\circ}\text{C to }+85\text{ }^{\circ}\text{C}$; $V_{DD} > 2.0\text{ V}$	-	-	$0.3V_{DD}$	V
V_{IH}	HIGH-level input voltage		$0.7V_{DD}$	-	-	V
I_{LI}	input leakage current	$V_I = V_{DD}$ or V_{SS}	-	0	-	μA
		post ESD event	-1	-	+1	μA
C_i	input capacitance		[5] -	-	7	pF
Outputs						
V_O	output voltage	on pins CLKOUT, INT, referring to external pull-up	-0.5	-	+5.5	V
		on pin BBS	1.8	-	4.2	V
		on pin SDO	-0.5	-	$V_{DD} + 0.5$	V
V_{OH}	HIGH output voltage	on pin SDO	$0.8V_{DD}$	-	V_{DD}	V
V_{OL}	LOW output voltage	on pins CLKOUT, INT, and SDO	V_{SS}	-	$0.2V_{DD}$	V
I_{OL}	LOW-level output current	output sink current; $V_{OL} = 0.4\text{ V}$				
		on pin SDA/CE	[6] 3	17	-	mA
		on all other outputs	1.0	-	-	mA

Table 78. Static characteristics...continued

$V_{DD} = 1.8\text{ V to }4.2\text{ V}$; $V_{SS} = 0\text{ V}$; $T_{amb} = -40\text{ }^{\circ}\text{C to }+85\text{ }^{\circ}\text{C}$, unless otherwise specified.

Symbol	Parameter	Conditions	Min	Typ	Max	Unit
I_{OH}	HIGH-level output current	output source current; on pin SDO; $V_{OH} = 3.8\text{ V}$; $V_{DD} = 4.2\text{ V}$	1.0	-	-	mA
I_{LO}	output leakage current	$V_O = V_{DD}$ or V_{SS}	-	0	-	μA
		post ESD event	-1	-	+1	μA

- [1] For reliable oscillator start-up at power-on: $V_{DD(po)min} = V_{DD(min)} + 0.3\text{ V}$.
- [2] Timer source clock = $\frac{1}{60}$ Hz, level of pins SDA/CE, SDI, and SCL is V_{DD} or V_{SS} .
- [3] When the device is supplied by the V_{BAT} pin instead of the V_{DD} pin, the current values for I_{BAT} are as specified for I_{DD} under the same conditions.
- [4] The I²C-bus and SPI-bus interfaces of PCA2129 are 5 V tolerant.
- [5] Tested on sample basis.
- [6] For further information, see [Figure 39](#).

12.1 Current consumption characteristics, typical

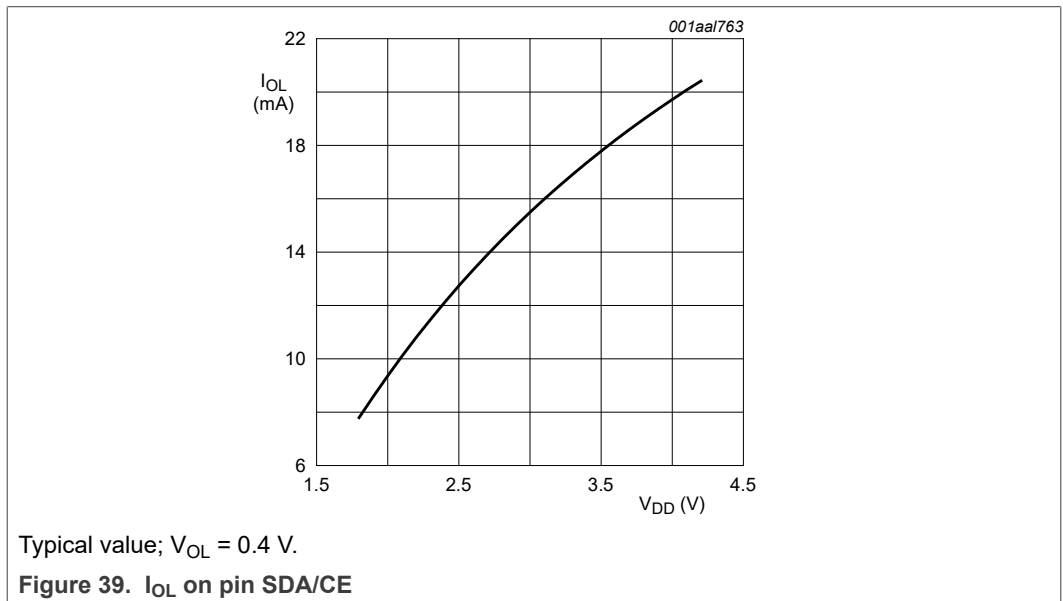

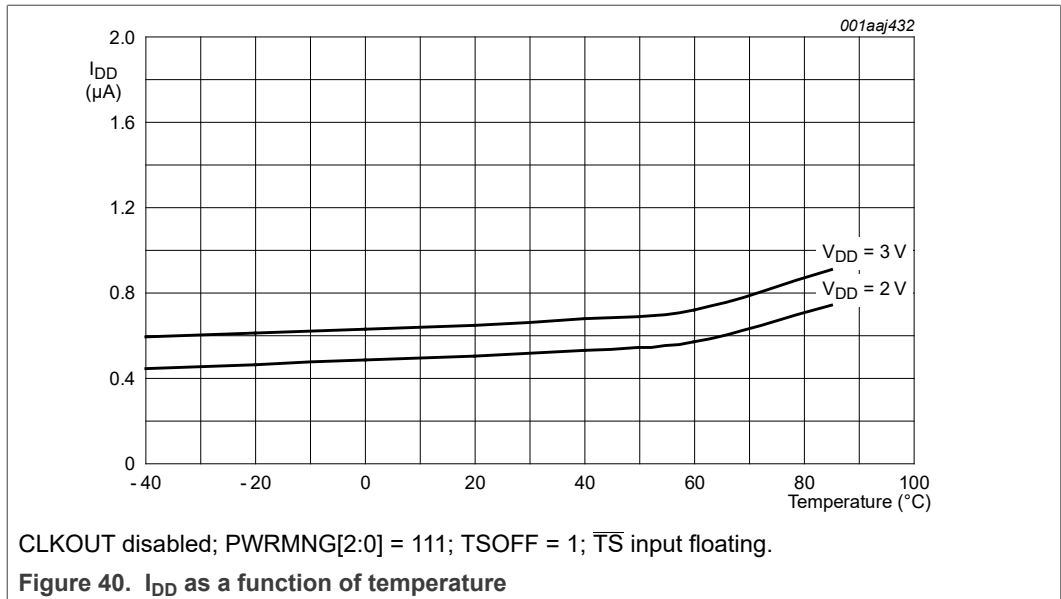

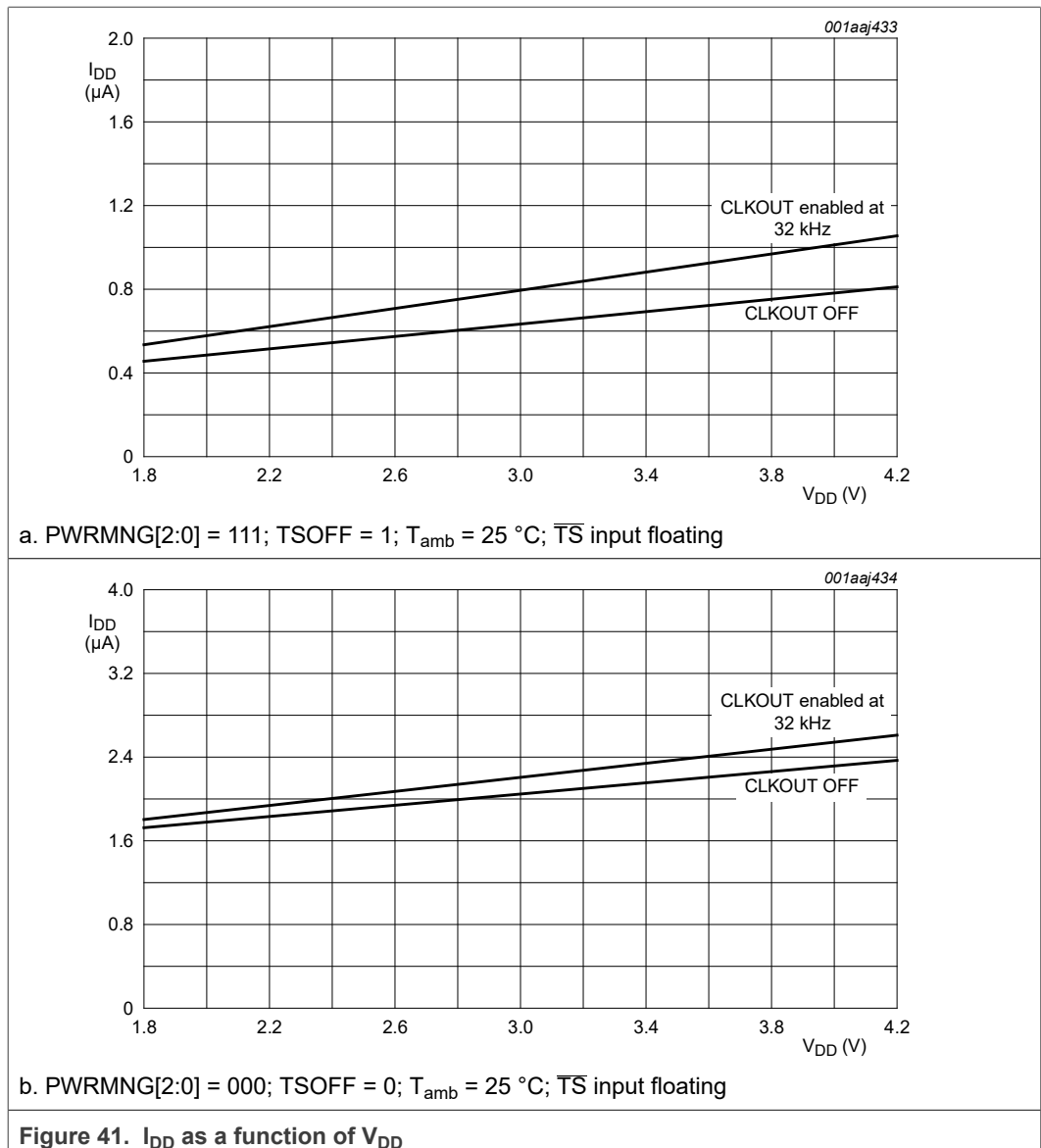

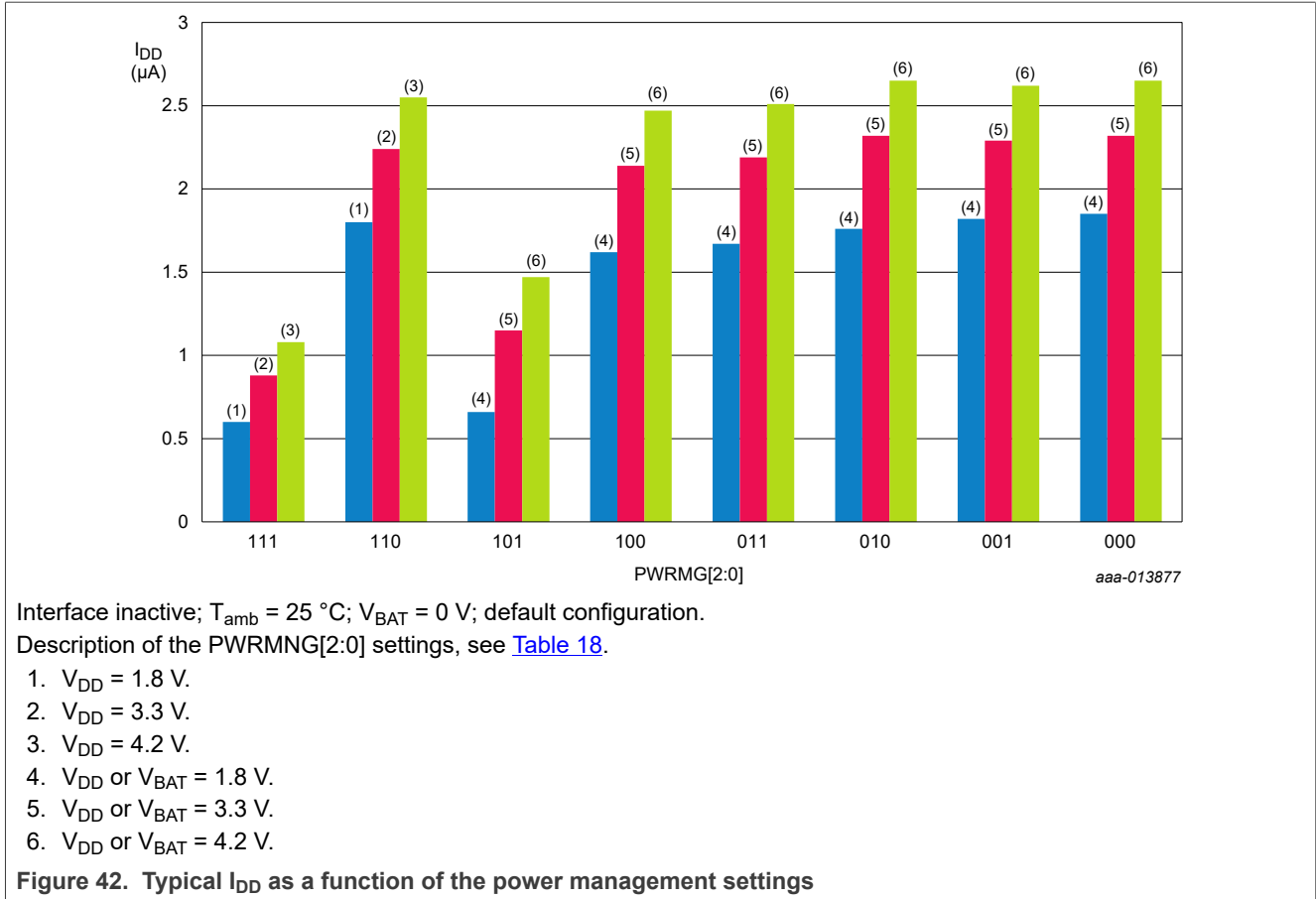

12.2 Frequency characteristics

Table 79. Frequency characteristics

V_{DD} = 1.8 V to 4.2 V; V_{SS} = 0 V; T_{amb} = +25 °C, unless otherwise specified.

Symbol	Parameter	Conditions	Min	Typ	Max	Unit	
f _o	output frequency	on pin CLKOUT; V _{DD} or V _{BAT} = 3.3 V; COF[2:0] = 000; AO[3:0] = 1000	-	32.768	-	kHz	
Δf/f	frequency stability	V _{DD} or V _{BAT} = 3.3 V					
		T _{amb} = +23 °C (±2 °C)	[1][2]	-	±3	±5.8	ppm
		T _{amb} = -30 °C to +80 °C	[1][2]	-	±3	±8	ppm
		T _{amb} = -40 °C to -30 °C and T _{amb} = +80 °C to +85 °C	[1][2]	-	±5	±15	ppm
Δf _{xtal} /f _{xtal}	relative crystal frequency variation	crystal aging					
		first year	[3]	-	-	±3	ppm
		ten years		-	-	±8	ppm

Table 79. Frequency characteristics...continued

$V_{DD} = 1.8\text{ V to }4.2\text{ V}$; $V_{SS} = 0\text{ V}$; $T_{amb} = +25\text{ }^{\circ}\text{C}$, unless otherwise specified.

Symbol	Parameter	Conditions	Min	Typ	Max	Unit
$\Delta f/\Delta V$	frequency variation with voltage	on pin CLKOUT	-	± 1	-	ppm/V

- [1] ± 1 ppm corresponds to a time deviation of ± 0.0864 seconds per day.
- [2] Only valid if CLKOUT frequencies are not equal to 32.768 kHz or if CLKOUT is disabled.
- [3] Not production tested. Effects of reflow soldering are included (see [1]).

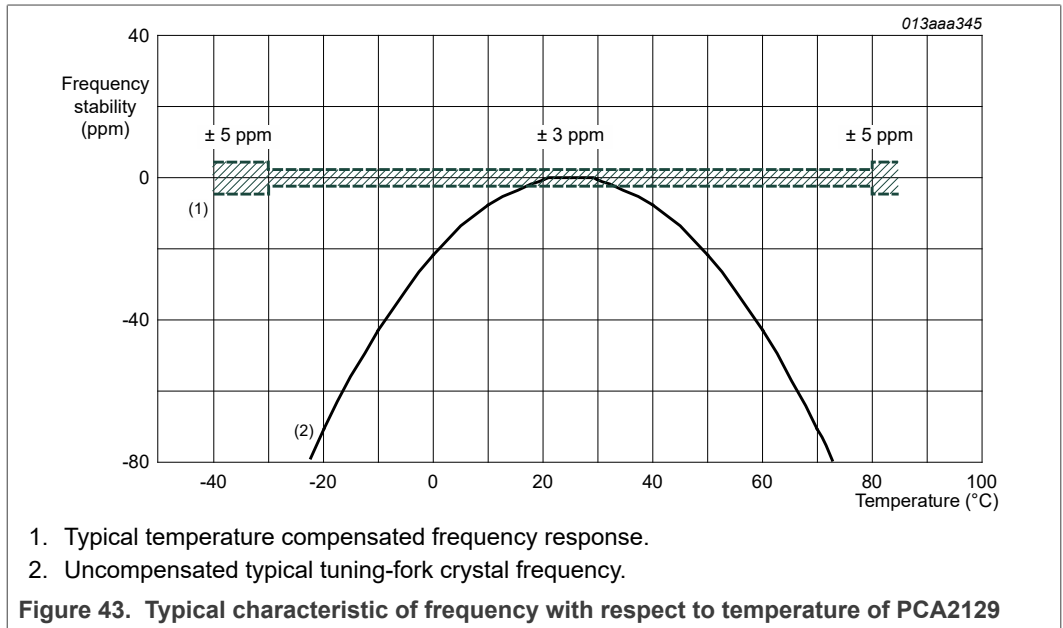

13 Dynamic characteristics

13.1 SPI-bus timing characteristics

Table 80. SPI-bus characteristics

$V_{DD} = 1.8\text{ V to }4.2\text{ V}$; $V_{SS} = 0\text{ V}$; $T_{amb} = -40\text{ }^{\circ}\text{C to }+85\text{ }^{\circ}\text{C}$, unless otherwise specified. All timing values are valid within the operating supply voltage at ambient temperature and referenced to V_{IL} and V_{IH} with an input voltage swing of V_{SS} to V_{DD} (see Figure 44).

Symbol	Parameter	Conditions	$V_{DD} = 1.8\text{ V}$		$V_{DD} = 4.2\text{ V}$		Unit
			Min	Max	Min	Max	
Pin SCL							
$f_{\text{clk(SCL)}}$	SCL clock frequency		-	2.0	-	6.5	MHz
t_{SCL}	SCL time		800	-	140	-	ns
$t_{\text{clk(H)}}$	clock HIGH time		100	-	70	-	ns
$t_{\text{clk(L)}}$	clock LOW time		400	-	70	-	ns
t_r	rise time	for SCL signal	-	100	-	100	ns

Table 80. SPI-bus characteristics...continued

$V_{DD} = 1.8\text{ V to }4.2\text{ V}$; $V_{SS} = 0\text{ V}$; $T_{amb} = -40\text{ }^{\circ}\text{C to }+85\text{ }^{\circ}\text{C}$, unless otherwise specified. All timing values are valid within the operating supply voltage at ambient temperature and referenced to V_{IL} and V_{IH} with an input voltage swing of V_{SS} to V_{DD} (see [Figure 44](#)).

Symbol	Parameter	Conditions	$V_{DD} = 1.8\text{ V}$		$V_{DD} = 4.2\text{ V}$		Unit
			Min	Max	Min	Max	
t_f	fall time	for SCL signal	-	100	-	100	ns
Pin SDA/CE							
$t_{su(CE_N)}$	CE_N set-up time		60	-	30	-	ns
$t_{h(CE_N)}$	CE_N hold time		40	-	25	-	ns
$t_{rec(CE_N)}$	CE_N recovery time		100	-	30	-	ns
$t_w(CE_N)$	CE_N pulse width		-	0.99	-	0.99	s
Pin SDI							
t_{su}	set-up time	set-up time for SDI data	70	-	20	-	ns
t_h	hold time	hold time for SDI data	70	-	20	-	ns
Pin SDO							
$t_{d(R)SDO}$	SDO read delay time	$C_L = 50\text{ pF}$	-	225	-	55	ns
$t_{dis(SDO)}$	SDO disable time		[1]	90	-	25	ns
$t_t(SDI-SDO)$	transition time from SDI to SDO	to avoid bus conflict	0	-	0	-	ns

[1] No load value; bus is held up by bus capacitance; use RC time constant with application values.

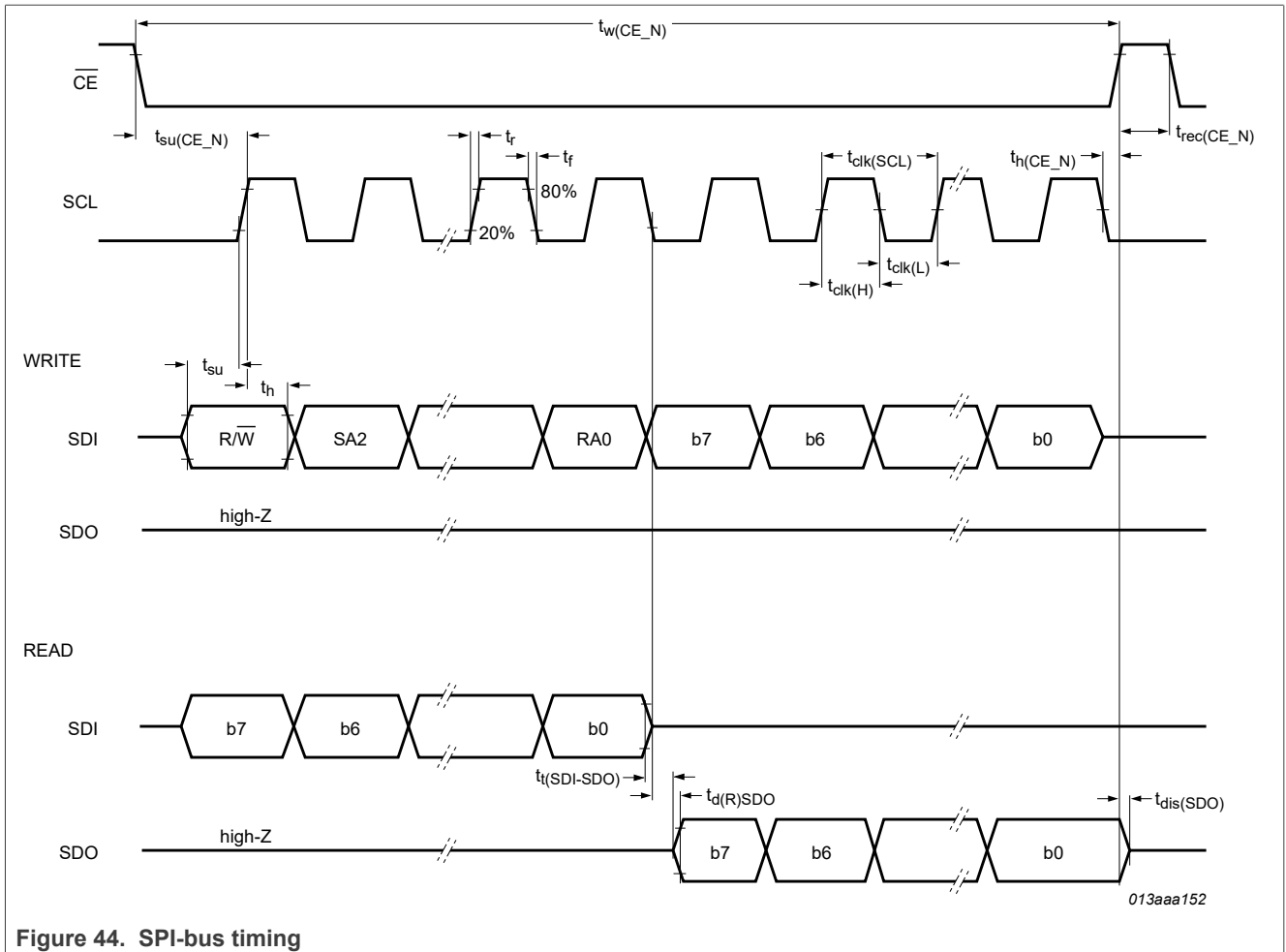

Figure 44. SPI-bus timing

13.2 I²C-bus timing characteristics

Table 81. I²C-bus characteristics

All timing characteristics are valid within the operating supply voltage and ambient temperature range and reference to 30 % and 70 % with an input voltage swing of V_{SS} to V_{DD} (see Figure 45).

Symbol	Parameter	Standard mode		Fast-mode (Fm)		Unit
		Min	Max	Min	Max	
Pin SCL						
f_{SCL}	SCL clock frequency	[1] 0	100	0	400	kHz
t_{LOW}	LOW period of the SCL clock	4.7	-	1.3	-	μs
t_{HIGH}	HIGH period of the SCL clock	4.0	-	0.6	-	μs
Pin SDA/\overline{CE}						
$t_{SU,DAT}$	data set-up time	250	-	100	-	ns
$t_{HD,DAT}$	data hold time	0	-	0	-	ns
Pins SCL and SDA/\overline{CE}						
t_{BUF}	bus free time between a STOP and START condition	4.7	-	1.3	-	μs

Table 81. I²C-bus characteristics...continued

All timing characteristics are valid within the operating supply voltage and ambient temperature range and reference to 30 % and 70 % with an input voltage swing of V_{SS} to V_{DD} (see Figure 45).

Symbol	Parameter	Standard mode		Fast-mode (Fm)		Unit
		Min	Max	Min	Max	
t _{SU;STO}	set-up time for STOP condition	4.0	-	0.6	-	μs
t _{HD;STA}	hold time (repeated) START condition	4.0	-	0.6	-	μs
t _{SU;STA}	set-up time for a repeated START condition	4.7	-	0.6	-	μs
t _r	rise time of both SDA and SCL signals	[2][3][4]	1 000	20 + 0.1C _b	300	ns
t _f	fall time of both SDA and SCL signals	[2][3][4]	300	20 + 0.1C _b	300	ns
t _{VD;ACK}	data valid acknowledge time	[5]	0.1	0.1	0.9	μs
t _{VD;DAT}	data valid time	[6]	300	75	-	ns
t _{SP}	pulse width of spikes that must be suppressed by the input filter	[7]	-	50	50	ns

- [1] The minimum SCL clock frequency is limited by the bus time-out feature which resets the serial bus interface if either the SDA or SCL is held LOW for a minimum of 25 ms. The bus time-out feature must be disabled for DC operation.
- [2] A master device must internally provide a hold time of at least 300 ns for the SDA signal (refer to the V_{IL} of the SCL signal) in order to bridge the undefined region of the falling edge of SCL.
- [3] C_b is the total capacitance of one bus line in pF.
- [4] The maximum t_r for the SDA and SCL bus lines is 300 ns. The maximum fall time for the SDA output stage, t_f is 250 ns. This allows series protection resistors to be connected between the SDA/CE pin, the SCL pin, and the SDA/SCL bus lines without exceeding the maximum t_r.
- [5] t_{VD;ACK} is the time of the acknowledgement signal from SCL LOW to SDA (out) LOW.
- [6] t_{VD;DAT} is the minimum time for valid SDA (out) data following SCL LOW.
- [7] Input filters on the SDA and SCL inputs suppress noise spikes of less than 50 ns.

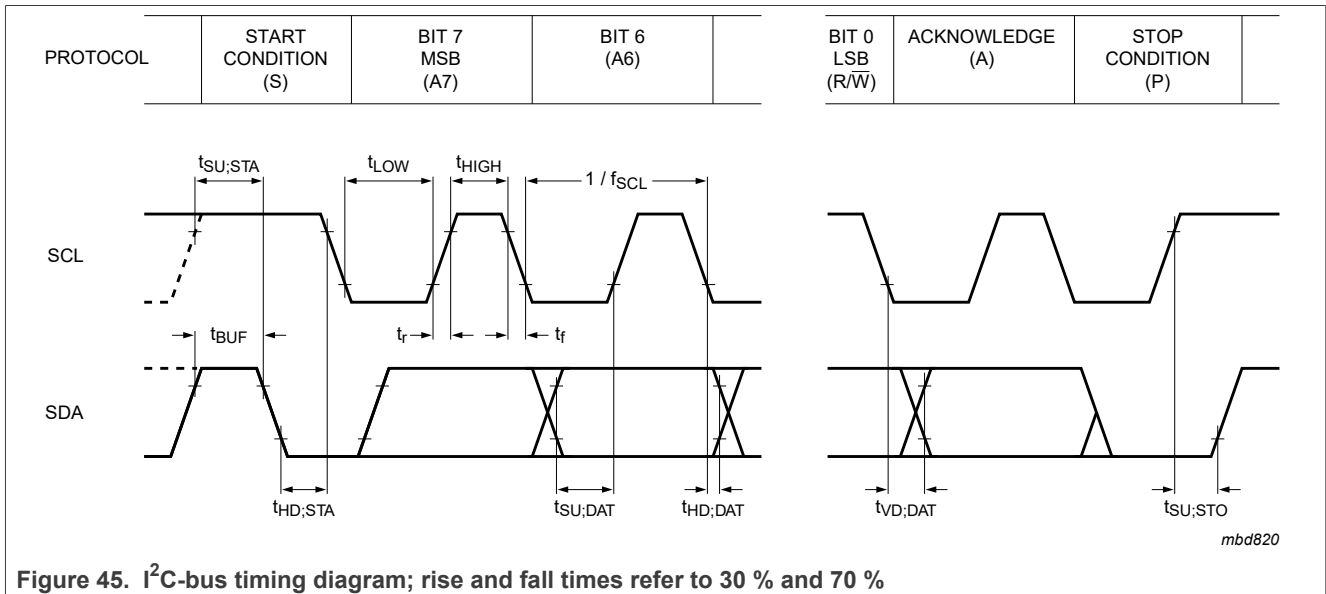
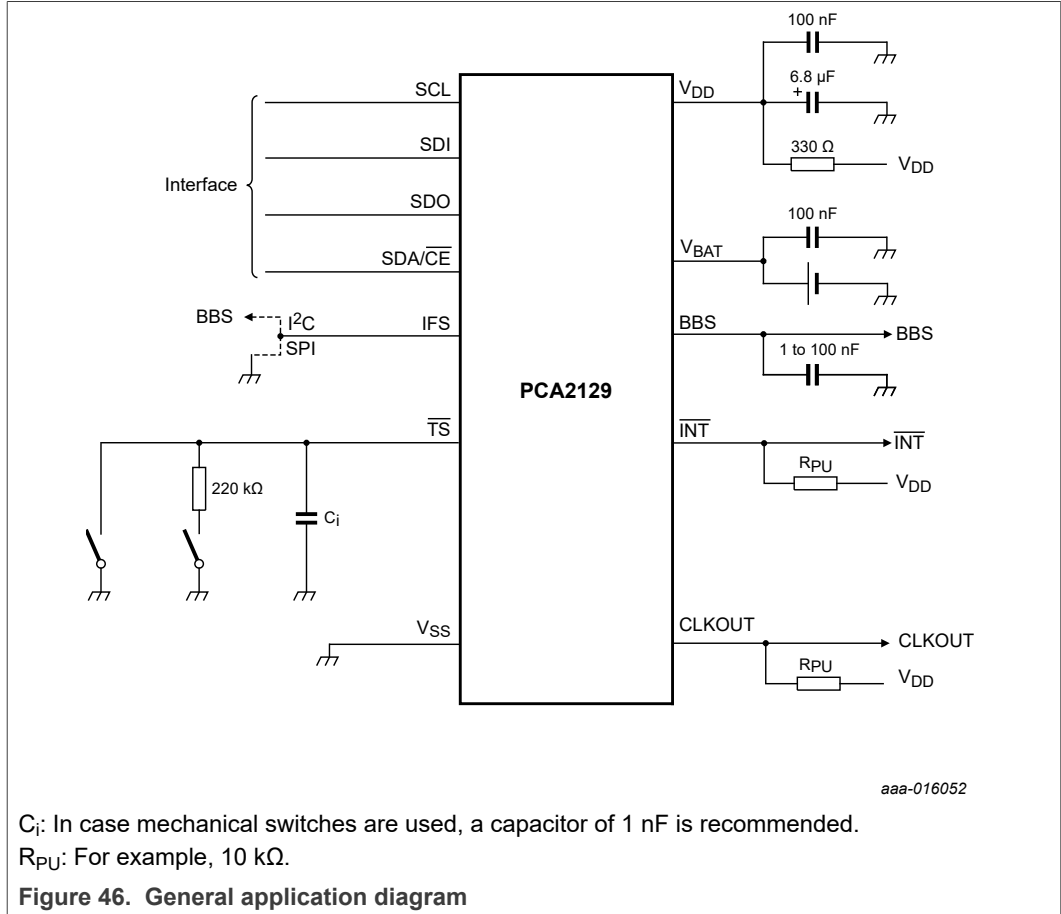

Figure 45. I²C-bus timing diagram; rise and fall times refer to 30 % and 70 %

14 Application information



For information about application configuration, see [\[1\]](#).

15 Test information

15.1 Quality information

This product has been qualified in accordance with the Automotive Electronics Council (AEC) standard *Q100 - Failure mechanism based stress test qualification for integrated circuits*, and is suitable for use in automotive applications.

UL Component Recognition



This (component or material) is Recognized by UL. Representative samples of this component have been evaluated by UL and meet applicable UL requirements.

16 Package outline

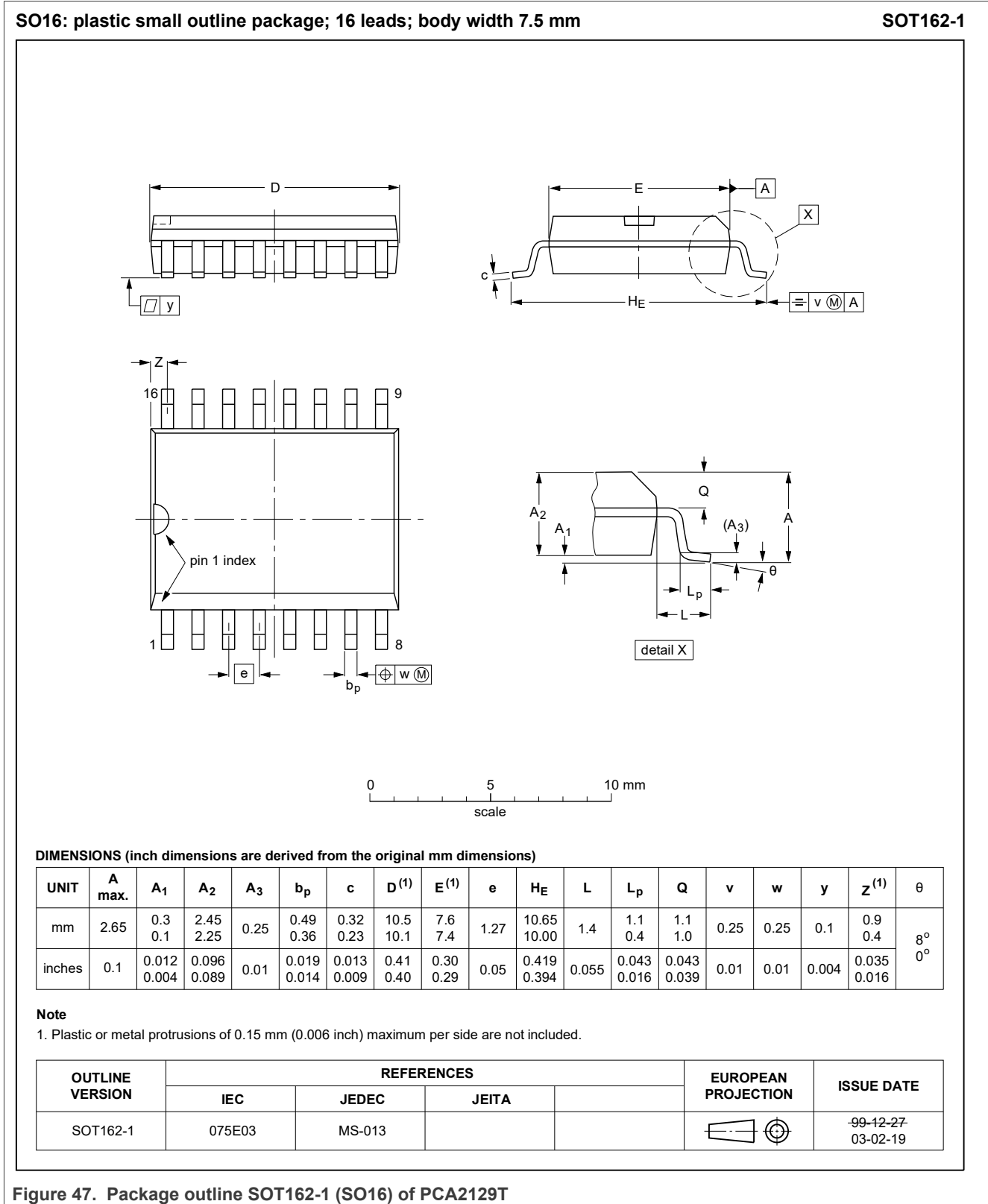

Figure 47. Package outline SOT162-1 (SO16) of PCA2129T

17 Packing information

17.1 Tape and reel information

For tape and reel packing information, see [\[5\]](#) for the PCA2129T.

18 Soldering

For information about soldering, see [\[1\]](#).

18.1 Footprint information

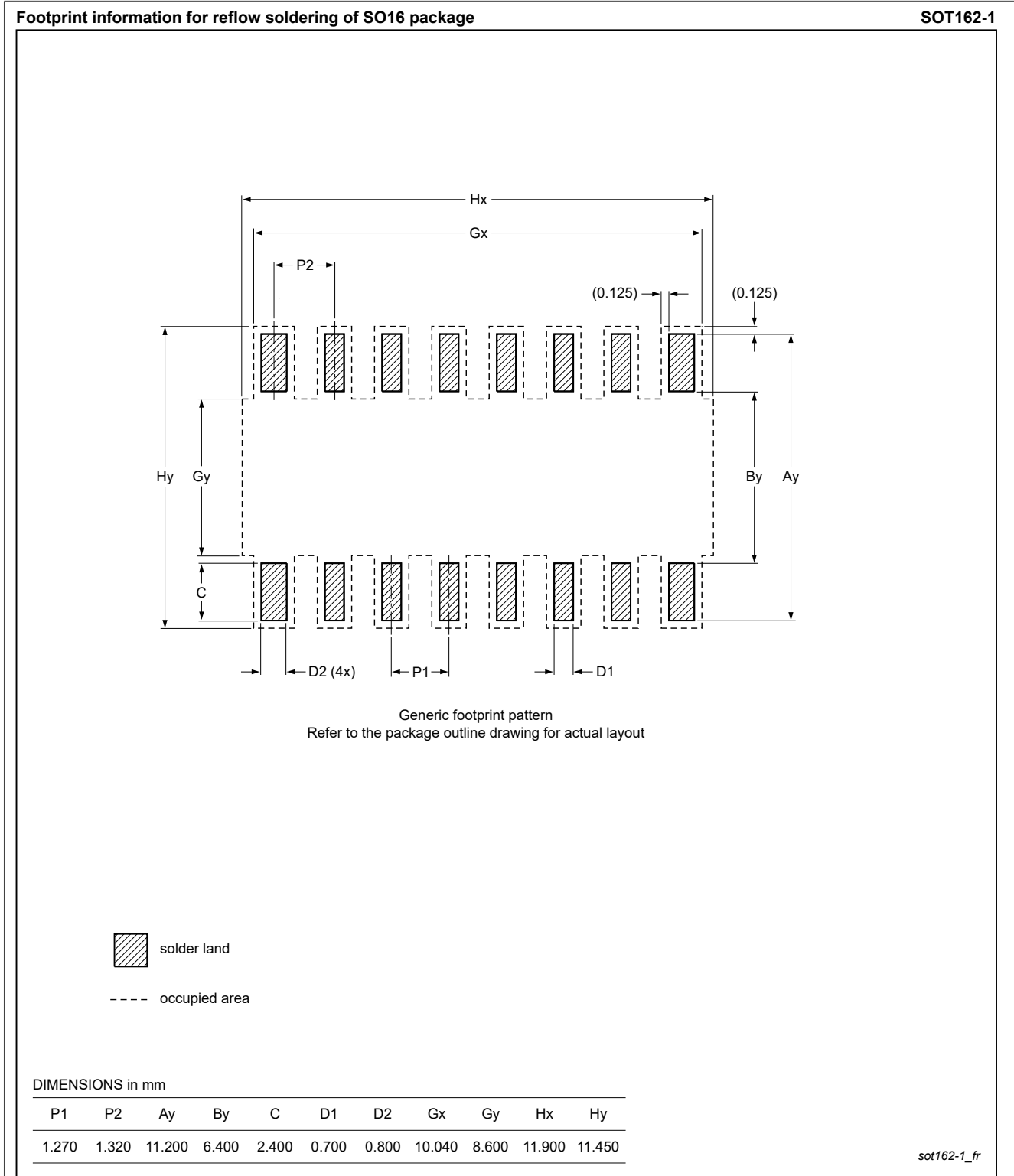

Figure 48. Footprint information for reflow soldering of SOT162-1 (SO16) of PCA2129T

19 Appendix

19.1 Real-Time Clock selection

Table 82. Selection of Real-Time Clocks

Type name	Alarm, Timer, Watchdog	Interrupt output	Interface	I _{DD} , typical (nA)	Battery backup	Timestamp, tamper input	AEC-Q100 compliant	Special features	Packages
PCF8563	X	1	I ² C	250	-	-	-	-	SO8, TSSOP8, HVSON10
PCF8564A	X	1	I ² C	250	-	-	-	integrated oscillator caps	WLCSP
PCA8565	X	1	I ² C	600	-	-	grade 1	high robustness, T _{amb} = -40 °C to 125 °C	TSSOP8, HVSON10
PCA8565A	X	1	I ² C	600	-	-	-	integrated oscillator caps, T _{amb} = -40 °C to 125 °C	WLCSP
PCF85063	-	1	I ² C	220	-	-	-	basic functions only, no alarm	HXSON8
PCF85063A	X	1	I ² C	220	-	-	-	tiny package	SO8, DFN2626-10
PCF85063B	X	1	SPI	220	-	-	-	tiny package	DFN2626-10
PCF85263A	X	2	I ² C	230	X	X	-	time stamp, battery backup, stopwatch 1/100 s	SO8, TSSOP10, TSSOP8, DFN2626-10
PCF85263B	X	2	SPI	230	X	X	-	time stamp, battery backup, stopwatch 1/100s	TSSOP10, DFN2626-10
PCF85363A	X	2	I ² C	230	X	X	-	time stamp, battery backup, stopwatch 1/100s, 64 Byte RAM	TSSOP10, DFN2626-10
PCF85363B	X	2	SPI	230	X	X	-	time stamp, battery backup, stopwatch 1/100s, 64 Byte RAM	TSSOP10, DFN2626-10
PCF8523	X	2	I ² C	150	X	-	-	lowest power 150 nA in operation, FM+ 1 MHz	SO8, HVSON8, TSSOP14, WLCSP
PCF2123	X	1	SPI	100	-	-	-	lowest power 100 nA in operation	TSSOP14, HVQFN16
PCF2127	X	1	I ² C and SPI	500	X	X	-	temperature compensated, quartz built in, calibrated, 512 Byte RAM	SO16
PCF2127A	X	1	I ² C and SPI	500	X	X	-	temperature compensated, quartz built in, calibrated, 512 Byte RAM	SO20

Table 82. Selection of Real-Time Clocks...continued

Type name	Alarm, Timer, Watchdog	Interrupt output	Interface	I _{DD} , typical (nA)	Battery backup	Timestamp, tamper input	AEC-Q100 compliant	Special features	Packages
PCF2129	X	1	I ² C and SPI	500	X	X	-	temperature compensated, quartz built in, calibrated	SO16
PCF2129A	X	1	I ² C and SPI	500	X	X	-	temperature compensated, quartz built in, calibrated	SO20
PCA2129	X	1	I ² C and SPI	500	X	X	grade 3	temperature compensated, quartz built in, calibrated	SO16
PCA21125	X	1	SPI	820	-	-	grade 1	high robustness, T _{amb} = -40 °C to 125 °C	TSSOP14

20 Abbreviations

Table 83. Abbreviations

Acronym	Description
AM	Ante Meridiem
BCD	Binary Coded Decimal
CDM	Charged Device Model
CMOS	Complementary Metal-Oxide Semiconductor
DC	Direct Current
GPS	Global Positioning System
HBM	Human Body Model
I ² C	Inter-Integrated Circuit
IC	Integrated Circuit
LSB	Least Significant Bit
MCU	Microcontroller Unit
MM	Machine Model
MSB	Most Significant Bit
PM	Post Meridiem
POR	Power-On Reset
PORO	Power-On Reset Override
PPM	Parts Per Million
RC	Resistance-Capacitance
RTC	Real-Time Clock
SCL	Serial CLock line
SDA	Serial DATa line
SPI	Serial Peripheral Interface
SRAM	Static Random Access Memory
TCXO	Temperature Compensated Xtal Oscillator
Xtal	crystal

21 References

- [1] AN11186 Application and soldering information for the PCA2129 and PCF2129 TCXO RTC
- [2] JESD22-A114 Electrostatic Discharge (ESD) Sensitivity Testing Human Body Model (HBM)
- [3] JESD22-C101 Field-Induced Charged-Device Model Test Method for Electrostatic-Discharge-Withstand Thresholds of Microelectronic Components
- [4] JESD78 IC Latch-Up Test
- [5] SOT162-1_518 SO16; Reel pack; SMD, 13", packing information
- [6] UM10204 I²C-bus specification and user manual
- [7] UM10569 Store and transport requirements

22 Revision history

Table 84. Revision history

Document ID	Release date	Data sheet status	Change notice	Supersedes
PCA2129 v.6	20220718	Product data sheet	-	PCA2129T v.5
Modifications:	<ul style="list-style-type: none"> • Added UL certification information • Updated layout of Section 4 			
PCA2129 v.5	20141219	Product data sheet	-	PCA2129T v.4
PCA2129T v.4	20130711	Product data sheet	-	PCA2129T v.3
PCA2129 v.3	20130124	Product data sheet	-	PCA2129 v.2.1
PCA2129 v.2.1	20121114	Product data sheet	-	PCA2129 v.2
PCA2129 v.2	20121113	Product data sheet	-	PCA2129 v.1
PCA2129 v.1	20111027	Objective data sheet	-	-

23 Legal information

23.1 Data sheet status

Document status ^{[1][2]}	Product status ^[3]	Definition
Objective [short] data sheet	Development	This document contains data from the objective specification for product development.
Preliminary [short] data sheet	Qualification	This document contains data from the preliminary specification.
Product [short] data sheet	Production	This document contains the product specification.

[1] Please consult the most recently issued document before initiating or completing a design.

[2] The term 'short data sheet' is explained in section "Definitions".

[3] The product status of device(s) described in this document may have changed since this document was published and may differ in case of multiple devices. The latest product status information is available on the Internet at URL <http://www.nxp.com>.

23.2 Definitions

Draft — A draft status on a document indicates that the content is still under internal review and subject to formal approval, which may result in modifications or additions. NXP Semiconductors does not give any representations or warranties as to the accuracy or completeness of information included in a draft version of a document and shall have no liability for the consequences of use of such information.

Short data sheet — A short data sheet is an extract from a full data sheet with the same product type number(s) and title. A short data sheet is intended for quick reference only and should not be relied upon to contain detailed and full information. For detailed and full information see the relevant full data sheet, which is available on request via the local NXP Semiconductors sales office. In case of any inconsistency or conflict with the short data sheet, the full data sheet shall prevail.

Product specification — The information and data provided in a Product data sheet shall define the specification of the product as agreed between NXP Semiconductors and its customer, unless NXP Semiconductors and customer have explicitly agreed otherwise in writing. In no event however, shall an agreement be valid in which the NXP Semiconductors product is deemed to offer functions and qualities beyond those described in the Product data sheet.

23.3 Disclaimers

Limited warranty and liability — Information in this document is believed to be accurate and reliable. However, NXP Semiconductors does not give any representations or warranties, expressed or implied, as to the accuracy or completeness of such information and shall have no liability for the consequences of use of such information. NXP Semiconductors takes no responsibility for the content in this document if provided by an information source outside of NXP Semiconductors.

In no event shall NXP Semiconductors be liable for any indirect, incidental, punitive, special or consequential damages (including - without limitation - lost profits, lost savings, business interruption, costs related to the removal or replacement of any products or rework charges) whether or not such damages are based on tort (including negligence), warranty, breach of contract or any other legal theory.

Notwithstanding any damages that customer might incur for any reason whatsoever, NXP Semiconductors' aggregate and cumulative liability towards customer for the products described herein shall be limited in accordance with the Terms and conditions of commercial sale of NXP Semiconductors.

Right to make changes — NXP Semiconductors reserves the right to make changes to information published in this document, including without limitation specifications and product descriptions, at any time and without notice. This document supersedes and replaces all information supplied prior to the publication hereof.

Applications — Applications that are described herein for any of these products are for illustrative purposes only. NXP Semiconductors makes no representation or warranty that such applications will be suitable for the specified use without further testing or modification.

Customers are responsible for the design and operation of their applications and products using NXP Semiconductors products, and NXP Semiconductors accepts no liability for any assistance with applications or customer product design. It is customer's sole responsibility to determine whether the NXP Semiconductors product is suitable and fit for the customer's applications and products planned, as well as for the planned application and use of customer's third party customer(s). Customers should provide appropriate design and operating safeguards to minimize the risks associated with their applications and products.

NXP Semiconductors does not accept any liability related to any default, damage, costs or problem which is based on any weakness or default in the customer's applications or products, or the application or use by customer's third party customer(s). Customer is responsible for doing all necessary testing for the customer's applications and products using NXP Semiconductors products in order to avoid a default of the applications and the products or of the application or use by customer's third party customer(s). NXP does not accept any liability in this respect.

Limiting values — Stress above one or more limiting values (as defined in the Absolute Maximum Ratings System of IEC 60134) will cause permanent damage to the device. Limiting values are stress ratings only and (proper) operation of the device at these or any other conditions above those given in the Recommended operating conditions section (if present) or the Characteristics sections of this document is not warranted. Constant or repeated exposure to limiting values will permanently and irreversibly affect the quality and reliability of the device.

Terms and conditions of commercial sale — NXP Semiconductors products are sold subject to the general terms and conditions of commercial sale, as published at <http://www.nxp.com/profile/terms>, unless otherwise agreed in a valid written individual agreement. In case an individual agreement is concluded only the terms and conditions of the respective agreement shall apply. NXP Semiconductors hereby expressly objects to applying the customer's general terms and conditions with regard to the purchase of NXP Semiconductors products by customer.

No offer to sell or license — Nothing in this document may be interpreted or construed as an offer to sell products that is open for acceptance or the grant, conveyance or implication of any license under any copyrights, patents or other industrial or intellectual property rights.

Suitability for use in automotive applications — This NXP product has been qualified for use in automotive applications. If this product is used by customer in the development of, or for incorporation into, products or services (a) used in safety critical applications or (b) in which failure could lead to death, personal injury, or severe physical or environmental damage (such products and services hereinafter referred to as “Critical Applications”), then customer makes the ultimate design decisions regarding its products and is solely responsible for compliance with all legal, regulatory, safety, and security related requirements concerning its products, regardless of any information or support that may be provided by NXP. As such, customer assumes all risk related to use of any products in Critical Applications and NXP and its suppliers shall not be liable for any such use by customer. Accordingly, customer will indemnify and hold NXP harmless from any claims, liabilities, damages and associated costs and expenses (including attorneys’ fees) that NXP may incur related to customer’s incorporation of any product in a Critical Application.

Quick reference data — The Quick reference data is an extract of the product data given in the Limiting values and Characteristics sections of this document, and as such is not complete, exhaustive or legally binding.

Export control — This document as well as the item(s) described herein may be subject to export control regulations. Export might require a prior authorization from competent authorities.

Translations — A non-English (translated) version of a document, including the legal information in that document, is for reference only. The English version shall prevail in case of any discrepancy between the translated and English versions.

Security — Customer understands that all NXP products may be subject to unidentified vulnerabilities or may support established security standards or specifications with known limitations. Customer is responsible for the design and operation of its applications and products throughout their lifecycles to reduce the effect of these vulnerabilities on customer’s applications and products. Customer’s responsibility also extends to other open and/or proprietary technologies supported by NXP products for use in customer’s applications. NXP accepts no liability for any vulnerability. Customer should regularly check security updates from NXP and follow up appropriately. Customer shall select products with security features that best meet rules, regulations, and standards of the intended application and make the ultimate design decisions regarding its products and is solely responsible for compliance with all legal, regulatory, and security related requirements concerning its products, regardless of any information or support that may be provided by NXP.

NXP has a Product Security Incident Response Team (PSIRT) (reachable at PSIRT@nxp.com) that manages the investigation, reporting, and solution release to security vulnerabilities of NXP products.

23.4 Trademarks

Notice: All referenced brands, product names, service names, and trademarks are the property of their respective owners.

NXP — wordmark and logo are trademarks of NXP B.V.

Tables

Tab. 1.	Ordering information	2	Tab. 35.	Years - years register (address 09h) bit allocation	26
Tab. 2.	Ordering options	2	Tab. 36.	Years - years register (address 09h) bit description	26
Tab. 3.	Pin description of PCA2129	4	Tab. 37.	Second_alarm - second alarm register (address 0Ah) bit allocation	28
Tab. 4.	Register overview	7	Tab. 38.	Second_alarm - second alarm register (address 0Ah) bit description	28
Tab. 5.	Control_1 - control and status register 1 (address 00h) bit allocation	9	Tab. 39.	Minute_alarm - minute alarm register (address 0Bh) bit allocation	29
Tab. 6.	Control_1 - control and status register 1 (address 00h) bit description	9	Tab. 40.	Minute_alarm - minute alarm register (address 0Bh) bit description	29
Tab. 7.	Control_2 - control and status register 2 (address 01h) bit allocation	10	Tab. 41.	Hour_alarm - hour alarm register (address 0Ch) bit allocation	29
Tab. 8.	Control_2 - control and status register 2 (address 01h) bit description	10	Tab. 42.	Hour_alarm - hour alarm register (address 0Ch) bit description	29
Tab. 9.	Control_3 - control and status register 3 (address 02h) bit allocation	10	Tab. 43.	Day_alarm - day alarm register (address 0Dh) bit allocation	30
Tab. 10.	Control_3 - control and status register 3 (address 02h) bit description	11	Tab. 44.	Day_alarm - day alarm register (address 0Dh) bit description	30
Tab. 11.	CLKOUT_ctl - CLKOUT control register (address 0Fh) bit allocation	11	Tab. 45.	Weekday_alarm - weekday alarm register (address 0Eh) bit allocation	30
Tab. 12.	CLKOUT_ctl - CLKOUT control register (address 0Fh) bit description	11	Tab. 46.	Weekday_alarm - weekday alarm register (address 0Eh) bit description	31
Tab. 13.	Temperature measurement period	12	Tab. 47.	Watchdog_timer_ctl - watchdog timer control register (address 10h) bit allocation	31
Tab. 14.	CLKOUT frequency selection	12	Tab. 48.	Watchdog_timer_ctl - watchdog timer control register (address 10h) bit description	32
Tab. 15.	Aging_offset - crystal aging offset register (address 19h) bit allocation	13	Tab. 49.	Watchdog_timer_val - watchdog timer value register (address 11h) bit allocation	32
Tab. 16.	Aging_offset - crystal aging offset register (address 19h) bit description	13	Tab. 50.	Watchdog_timer_val - watchdog timer value register (address 11h) bit description	32
Tab. 17.	Frequency correction at 25 °C, typical	13	Tab. 51.	Programmable watchdog timer	32
Tab. 18.	Power management control bit description	15	Tab. 52.	Flag location in register Control_2	34
Tab. 19.	Output pin BBS	18	Tab. 53.	Example values in register Control_2	34
Tab. 20.	Seconds - seconds and clock integrity register (address 03h) bit allocation	22	Tab. 54.	Example to clear only AF (bit 4)	34
Tab. 21.	Seconds - seconds and clock integrity register (address 03h) bit description	22	Tab. 55.	Example to clear only MSF (bit 7)	35
Tab. 22.	Seconds coded in BCD format	22	Tab. 56.	Timestp_ctl - timestamp control register (address 12h) bit allocation	36
Tab. 23.	Minutes - minutes register (address 04h) bit allocation	23	Tab. 57.	Timestp_ctl - timestamp control register (address 12h) bit description	36
Tab. 24.	Minutes - minutes register (address 04h) bit description	23	Tab. 58.	Sec_timestp - second timestamp register (address 13h) bit allocation	37
Tab. 25.	Hours - hours register (address 05h) bit allocation	23	Tab. 59.	Sec_timestp - second timestamp register (address 13h) bit description	37
Tab. 26.	Hours - hours register (address 05h) bit description	24	Tab. 60.	Min_timestp - minute timestamp register (address 14h) bit allocation	37
Tab. 27.	Days - days register (address 06h) bit allocation	24	Tab. 61.	Min_timestp - minute timestamp register (address 14h) bit description	37
Tab. 28.	Days - days register (address 06h) bit description	24	Tab. 62.	Hour_timestp - hour timestamp register (address 15h) bit allocation	37
Tab. 29.	Weekdays - weekdays register (address 07h) bit allocation	24	Tab. 63.	Hour_timestp - hour timestamp register (address 15h) bit description	38
Tab. 30.	Weekdays - weekdays register (address 07h) bit description	25	Tab. 64.	Day_timestp - day timestamp register (address 16h) bit allocation	38
Tab. 31.	Weekday assignments	25			
Tab. 32.	Months - months register (address 08h) bit allocation	25			
Tab. 33.	Months - months register (address 08h) bit description	25			
Tab. 34.	Month assignments in BCD format	26			

Tab. 65.	Day_timestp - day timestamp register (address 16h) bit description	38	Tab. 72.	First increment of time circuits after stop release	45
Tab. 66.	Mon_timestp - month timestamp register (address 17h) bit allocation	39	Tab. 73.	Interface selection input pin IFS	46
Tab. 67.	Mon_timestp - month timestamp register (address 17h) bit description	39	Tab. 74.	Serial interface	47
Tab. 68.	Year_timestp - year timestamp register (address 18h) bit allocation	39	Tab. 75.	Command byte definition	48
Tab. 69.	Year_timestp - year timestamp register (address 18h) bit description	39	Tab. 76.	I2C slave address byte	51
Tab. 70.	Battery switch-over and timestamp	39	Tab. 77.	Limiting values	53
Tab. 71.	Effect of bits MI and SI on pin INT and bit MSF	41	Tab. 78.	Static characteristics	54
			Tab. 79.	Frequency characteristics	59
			Tab. 80.	SPI-bus characteristics	60
			Tab. 81.	I2C-bus characteristics	62
			Tab. 82.	Selection of Real-Time Clocks	69
			Tab. 83.	Abbreviations	71
			Tab. 84.	Revision history	72

Figures

Fig. 1.	Block diagram of PCA2129	3	Fig. 22.	INT example for SI and MI when TI_TP is logic 0	42
Fig. 2.	Pin configuration for PCA2129 (SO16)	4	Fig. 23.	Example of shortening the INT pulse by clearing the MSF flag	43
Fig. 3.	Position of the stubs from the package assembly process	4	Fig. 24.	AF timing diagram	44
Fig. 4.	Handling address registers	6	Fig. 25.	STOP bit functional diagram	45
Fig. 5.	Battery switch-over behavior in standard mode with bit BIE set logic 1 (enabled)	16	Fig. 26.	STOP bit release timing	46
Fig. 6.	Battery switch-over behavior in direct switching mode with bit BIE set logic 1 (enabled)	17	Fig. 27.	Interface selection	47
Fig. 7.	Battery switch-over circuit, simplified block diagram	17	Fig. 28.	SDI, SDO configurations	47
Fig. 8.	Battery low detection behavior with bit BLIE set logic 1 (enabled)	18	Fig. 29.	Data transfer overview	48
Fig. 9.	Typical driving capability of VBBS: (VBBS - VDD) with respect to the output load current IBBS	19	Fig. 30.	SPI-bus write example	49
Fig. 10.	Power failure event due to battery discharge: reset occurs	20	Fig. 31.	SPI-bus read example	49
Fig. 11.	Dependency between POR and oscillator	21	Fig. 32.	Bit transfer	50
Fig. 12.	Power-On Reset (POR) system	21	Fig. 33.	Definition of START and STOP conditions	50
Fig. 13.	Power-On Reset Override (PORO) sequence, valid for both I2C-bus and SPI-bus	22	Fig. 34.	System configuration	50
Fig. 14.	Data flow of the time function	27	Fig. 35.	Acknowledgement on the I2C-bus	51
Fig. 15.	Access time for read/write operations	27	Fig. 36.	Bus protocol, writing to registers	52
Fig. 16.	Alarm function block diagram	28	Fig. 37.	Bus protocol, reading from registers	52
Fig. 17.	Alarm flag timing diagram	31	Fig. 38.	Device diode protection diagram of PCA2129	53
Fig. 18.	WD_CD set logic 1: watchdog activates an interrupt when timed out	33	Fig. 39.	IOL on pin SDA/CE	56
Fig. 19.	Timestamp detection with two push-buttons on the TS pin (for example, for tamper detection)	35	Fig. 40.	IDD as a function of temperature	57
Fig. 20.	Interrupt block diagram	41	Fig. 41.	IDD as a function of VDD	58
Fig. 21.	INT example for SI and MI when TI_TP is logic 1	42	Fig. 42.	Typical IDD as a function of the power management settings	59
			Fig. 43.	Typical characteristic of frequency with respect to temperature of PCA2129	60
			Fig. 44.	SPI-bus timing	62
			Fig. 45.	I2C-bus timing diagram; rise and fall times refer to 30 % and 70 %	63
			Fig. 46.	General application diagram	64
			Fig. 47.	Package outline SOT162-1 (SO16) of PCA2129T	65
			Fig. 48.	Footprint information for reflow soldering of SOT162-1 (SO16) of PCA2129T	67

Contents

1	General description	1	7.10.4	Pre-defined timers: second and minute interrupt	34
2	Features and benefits	1	7.10.5	Clearing flags	34
3	Applications	2	7.11	Timestamp function	35
4	Ordering information	2	7.11.1	Timestamp flag	35
4.1	Ordering options	2	7.11.2	Timestamp mode	36
5	Block diagram	3	7.11.3	Timestamp registers	36
6	Pinning information	4	7.11.3.1	Register Timestp_ctl	36
6.1	Pinning	4	7.11.3.2	Register Sec_timestp	37
6.2	Pin description	4	7.11.3.3	Register Min_timestp	37
7	Functional description	5	7.11.3.4	Register Hour_timestp	37
7.1	Register overview	5	7.11.3.5	Register Day_timestp	38
7.2	Control registers	9	7.11.3.6	Register Mon_timestp	39
7.2.1	Register Control_1	9	7.11.3.7	Register Year_timestp	39
7.2.2	Register Control_2	10	7.11.4	Dependency between Battery switch-over and timestamp	39
7.2.3	Register Control_3	10	7.12	Interrupt output, INT	40
7.3	Register CLKOUT_ctl	11	7.12.1	Minute and second interrupts	41
7.3.1	Temperature compensated crystal oscillator	11	7.12.2	INT pulse shortening	43
7.3.1.1	Temperature measurement	12	7.12.3	Watchdog timer interrupts	43
7.3.2	OTP refresh	12	7.12.4	Alarm interrupts	43
7.3.3	Clock output	12	7.12.5	Timestamp interrupts	44
7.4	Register Aging_offset	13	7.12.6	Battery switch-over interrupts	44
7.4.1	Crystal aging correction	13	7.12.7	Battery low detection interrupts	44
7.5	Power management functions	14	7.13	External clock test mode	44
7.5.1	Battery switch-over function	15	7.14	STOP bit function	45
7.5.1.1	Standard mode	16	8	Interfaces	46
7.5.1.2	Direct switching mode	16	8.1	SPI-bus interface	47
7.5.1.3	Battery switch-over disabled: only one power supply (VDD)	17	8.1.1	Data transmission	48
7.5.1.4	Battery switch-over architecture	17	8.2	I2C-bus interface	49
7.5.2	Battery low detection function	17	8.2.1	Bit transfer	49
7.5.3	Battery backup supply	18	8.2.2	START and STOP conditions	50
7.6	Oscillator stop detection function	19	8.2.3	System configuration	50
7.7	Reset function	20	8.2.4	Acknowledge	50
7.7.1	Power-On Reset (POR)	20	8.2.5	I2C-bus protocol	51
7.7.2	Power-On Reset Override (PORO)	21	8.3	Bus communication and battery backup operation	52
7.8	Time and date function	22	9	Internal circuitry	53
7.8.1	Register Seconds	22	10	Safety notes	53
7.8.2	Register Minutes	23	11	Limiting values	53
7.8.3	Register Hours	23	12	Static characteristics	54
7.8.4	Register Days	24	12.1	Current consumption characteristics, typical	56
7.8.5	Register Weekdays	24	12.2	Frequency characteristics	59
7.8.6	Register Months	25	13	Dynamic characteristics	60
7.8.7	Register Years	26	13.1	SPI-bus timing characteristics	60
7.8.8	Setting and reading the time	26	13.2	I2C-bus timing characteristics	62
7.9	Alarm function	27	14	Application information	64
7.9.1	Register Second_alarm	28	15	Test information	64
7.9.2	Register Minute_alarm	29	15.1	Quality information	64
7.9.3	Register Hour_alarm	29	16	Package outline	65
7.9.4	Register Day_alarm	30	17	Packing information	66
7.9.5	Register Weekday_alarm	30	17.1	Tape and reel information	66
7.9.6	Alarm flag	31	18	Soldering	66
7.10	Timer functions	31	18.1	Footprint information	67
7.10.1	Register Watchdg_tim_ctl	31	19	Appendix	68
7.10.2	Register Watchdg_tim_val	32	19.1	Real-Time Clock selection	68
7.10.3	Watchdog timer function	33			

20	Abbreviations	71
21	References	72
22	Revision history	72
23	Legal information	73

Please be aware that important notices concerning this document and the product(s) described herein, have been included in section 'Legal information'.

© 2022 NXP B.V.



All rights reserved.

For more information, please visit: <http://www.nxp.com>





Date of release: 18 July 2022
Document identifier: PCA2129

Looking for pricing, stock, or lifecycle information?

Click below to explore more details on WIN SOURCE:

-  [View PCA2129T/Q900/2 on WIN SOURCE](#)
-  [NXP / Nexperia Information](#)

Optimize Your Supply Chain with WIN SOURCE Solutions

-  Global Sourcing Solution
-  Obsolete Management
-  Cost Control Management
-  Shortage Management
-  Alternative Solution
-  Excess Inventory Management