



THE DATASHEET OF PA93



High Voltage Power Operational Amplifiers



FEATURES

- High Voltage — 400V ($\pm 200V$)
- Low Quiescent Current — 10mA
- High Output Current — 8A
- Programmable Current Limit

APPLICATIONS

- Piezoelectric Positioning
- High Voltage Instrumentation
- Electrostatic Transducers
- Programmable Power Supplies up to 390V



DESCRIPTION

The PA93 is a high voltage, low quiescent current MOSFET operational amplifier designed as a low cost solution for driving continuous output currents up to 8A and pulse currents up to 14A. The safe operating area (SOA) has no second breakdown limitations and can be observed for all type loads by choosing an appropriate current limiting resistor. The MOSFET output stage is biased AB for linear operation. External compensation provides flexibility in choosing bandwidth and slew rate for the application. Apex Microtechnology's Power SIP uses a minimum of board space allowing for high density circuit boards. The Power SIP is electrically isolated.

Figure 1: Equivalent Schematic

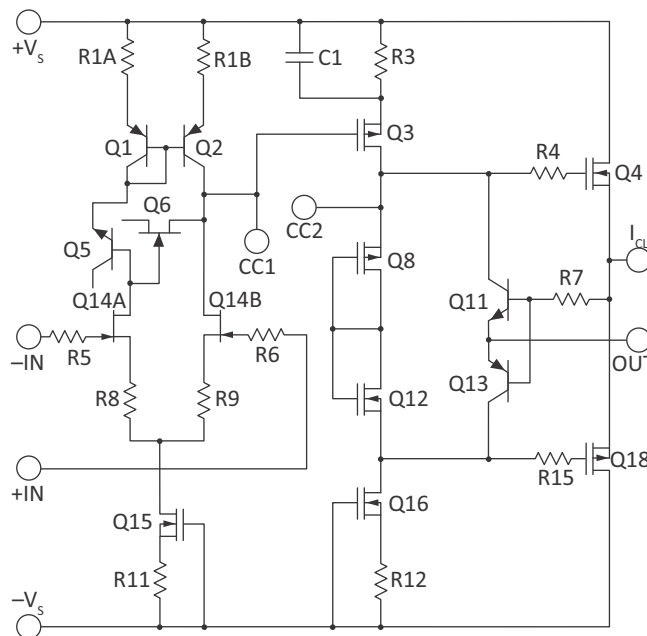

TYPICAL CONNECTIONS

Figure 2: Typical Connections

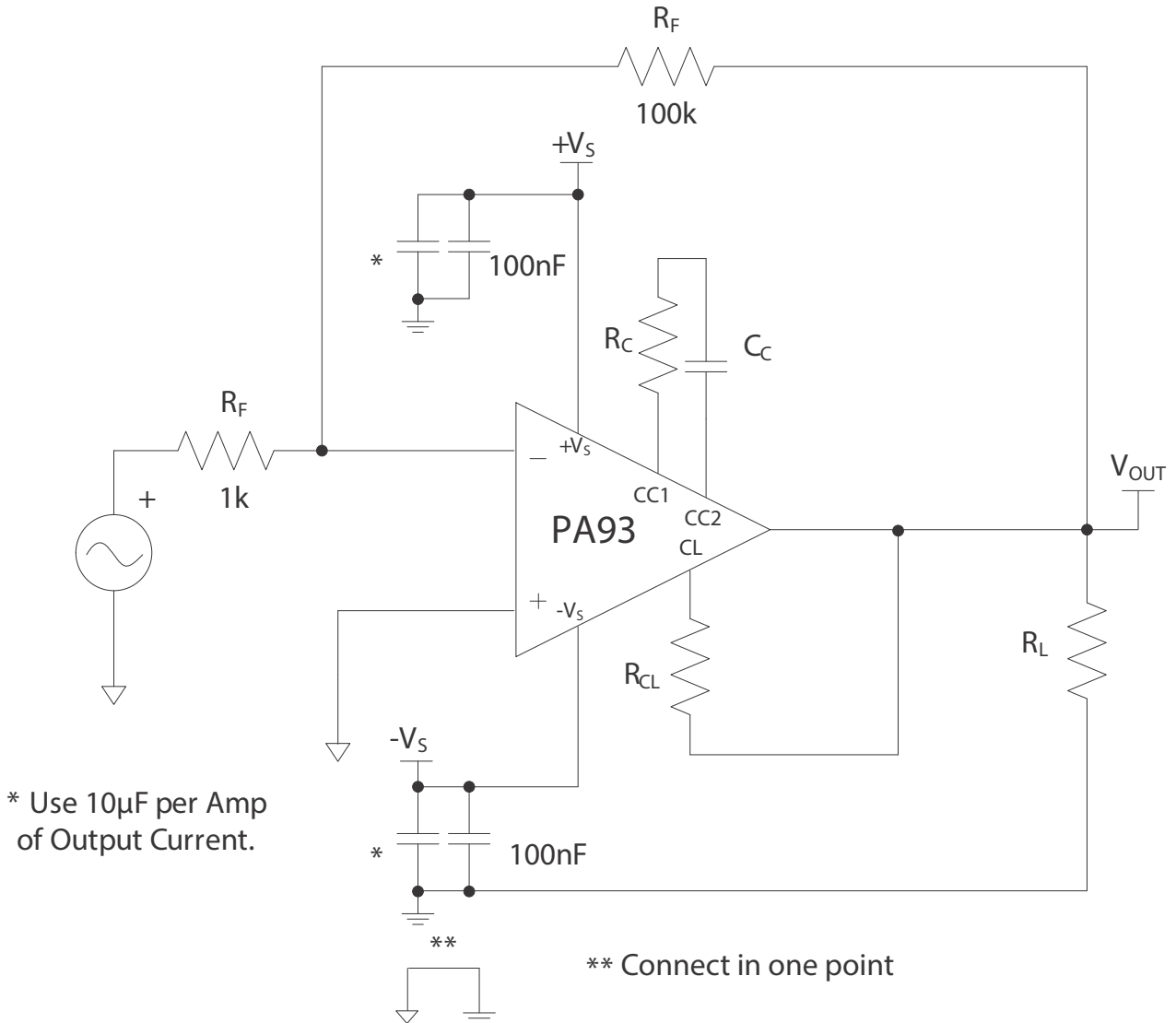

PINOUT AND DESCRIPTION TABLE

Figure 3: External Connections

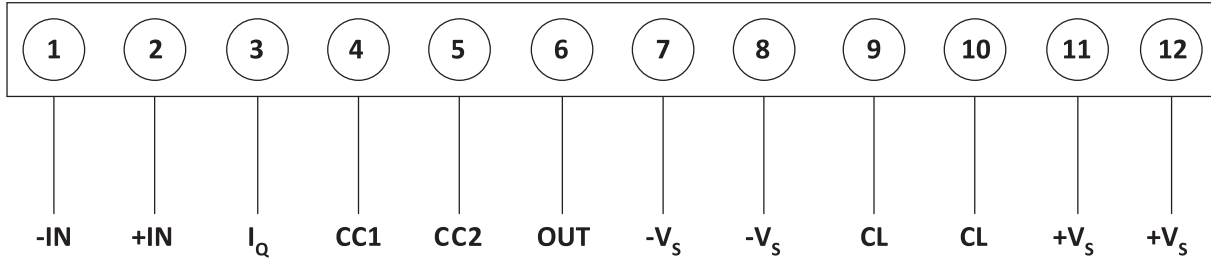

Pin Number	Name	Description
1	-IN	The inverting input.
2	+IN	The non-inverting input.
3	I _Q	Quiescent current reduction pin. Connect to pin 5 to disable the AB bias. See applicable section
4	CC1	Compensation Resistor connection, select value based on Phase Compensation. See applicable section
5	CC2	Compensation Capacitive connection, select value based on Phase Compensation. See applicable section
6	OUT	The output. Connect this pin to load and to the feedback resistors.
7, 8	-V _S	The negative supply rail. Pins 7 and 8 are internally connected.
9, 10	CL	Connect to the current limit resistor. Output current flows into/out of these pins through R _{CL} . The output pin and the load are connected to the other side of R _{CL} . Pins 9 and 10 are internally connected.
11, 12	+V _S	The positive supply rail. Pins 11 and 12 are internally connected.

SPECIFICATIONS

Unless otherwise noted: $T_C = 25^\circ\text{C}$, DC input specifications are \pm value given. Power supply voltage is typical rating. $R_C = 100\ \Omega$ $C_C = 220\text{pF}$.

ABSOLUTE MAXIMUM RATINGS

Parameter	Symbol	Min	Max	Units
Supply Voltage, total	$+V_S$ to $-V_S$		400	V
Output Current, source, sink, peak, within SOA	I_{OUT}		14	A
Power Dissipation, continuous @ $T_C = 25^\circ\text{C}$	P_D		125	W
Input Voltage, differential	$V_{IN(Diff)}$	-20	+20	V
Input Voltage, common mode	V_{CM}	$-V_S$	$+V_S$	V
Temperature, pin solder, 10s max.			+260	$^\circ\text{C}$
Temperature, junction ¹	T_J		+150	$^\circ\text{C}$
Temperature Range, storage		-55	+125	$^\circ\text{C}$
Operating Temperature Range, case	T_C	-40	+85	$^\circ\text{C}$

1. Long term operation at the maximum junction temperature will result in reduced product life. Derate internal power dissipation to achieve high MTTF.

The PA93 is constructed from MOSFET transistors. ESD handling procedures must be observed.

CAUTION

The substrate contains beryllia (BeO). Do not crush, machine, or subject to temperatures in excess of 850°C to avoid generating toxic fumes.

INPUT

Parameter	Test Conditions	Min	Typ	Max	Units
Offset Voltage, initial			2	10	mV
Offset Voltage vs. Temperature	Full temp range		15	50	$\mu\text{V}/^\circ\text{C}$
Offset Voltage vs. Supply			10	25	$\mu\text{V}/\text{V}$
Offset Voltage vs. Time			75		$\mu\text{V}/\text{kh}$
Bias Current, initial			200	2000	pA
Bias Current vs. Supply			4		pA/V
Offset Current, initial			50	500	pA
Input Impedance, DC			10^{11}		Ω
Input Capacitance			4		pF
Common Mode Voltage Range ¹		$\pm V_S \mp 15$			V
Common Mode Rejection, DC	$V_{CM} = \pm 90\text{V}$	80	98		dB
Noise	100 kHz BW, $R_S = 1\ \text{k}\Omega$, $C_C = 10\text{pF}$		1		$\mu\text{V RMS}$

1. $+V_S$ and $-V_S$ denote the positive and negative power supply rail respectively.

GAIN

Parameter	Test Conditions	Min	Typ	Max	Units
Open Loop @ 15 Hz	$R_L = 2\text{ k}\Omega$, $C_C = 10\text{ pF}$	94	111		dB
Gain Bandwidth Product @ 1 MHz	$R_L = 2\text{ k}\Omega$, $C_C = 10\text{ pF}$		12		MHz
Power Bandwidth	$R_L = 2\text{ k}\Omega$, $C_C = 10\text{ pF}$		30		kHz
Phase Margin	Full temp range		60		°

OUTPUT

Parameter	Test Conditions	Min	Typ	Max	Units
Voltage Swing ¹	$I_{OUT} = 8\text{ A}$	$\pm V_S \mp 12$	$\pm V_S \mp 10$		V
Current, continuous		8			A
Slew Rate, $A_V = 100$	$C_C = 10\text{ pF}$		50		V/ μs
Capacitive Load, $A_V = +1$	Full temp range	1			nF
Settling Time to 0.1%	$C_C = 10\text{ pF}$, 2V step		1		μs
Resistance, no load			10		Ω

1. $+V_S$ and $-V_S$ denote the positive and negative power supply rail respectively.

POWER SUPPLY

Parameter	Test Conditions	Min	Typ	Max	Units
Voltage ¹		± 40	± 150	± 200	V
Current, quiescent			10	14	mA

1. Derate max supply rating 0.625 V/°C below 25°C case. No derating needed above 25°C case.

THERMAL

Parameter	Test Conditions	Min	Typ	Max	Units
Resistance, AC, junction to case ¹	Full temp range, $F > 60\text{ Hz}$			0.7	°C/W
Resistance, DC, junction to case	Full temp range, $F < 60\text{ Hz}$			1	°C/W
Resistance, junction to air	Full temp range		30		°C/W
Temperature Range, case	Meets full range specifications	-25		+85	°C

1. Rating applies if the output current alternates between both output transistors at a rate faster than 60 Hz.

TYPICAL PERFORMANCE GRAPHS

Figure 4: Power Derating

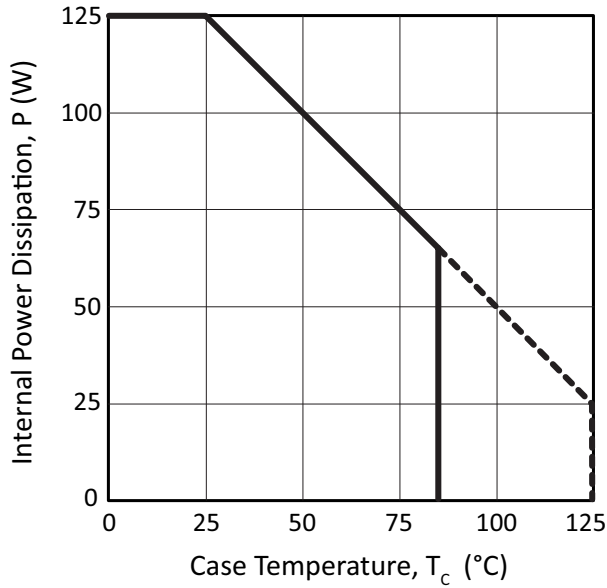

Figure 5: Normalized Quiescent Current

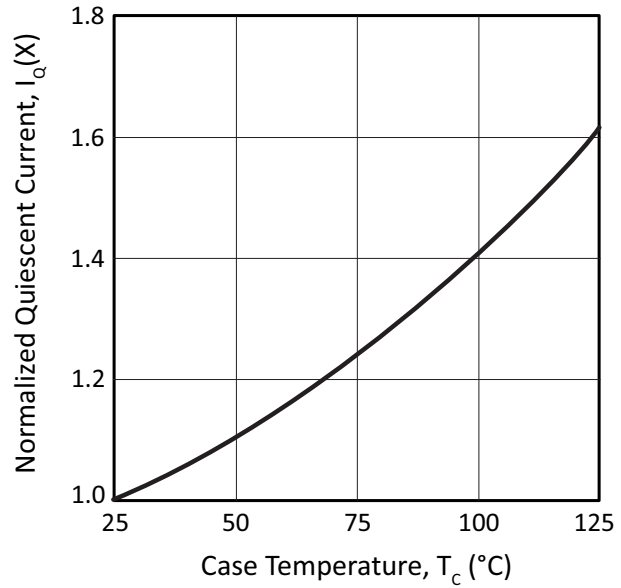

Figure 6: Small Signal Response

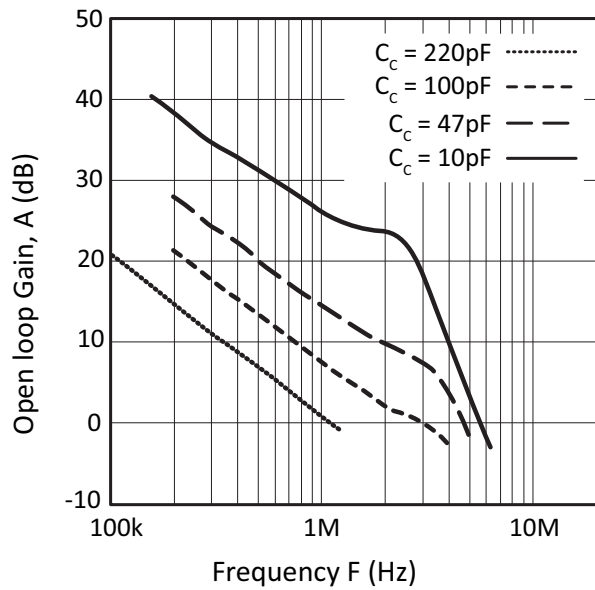

Figure 7: Phase Response

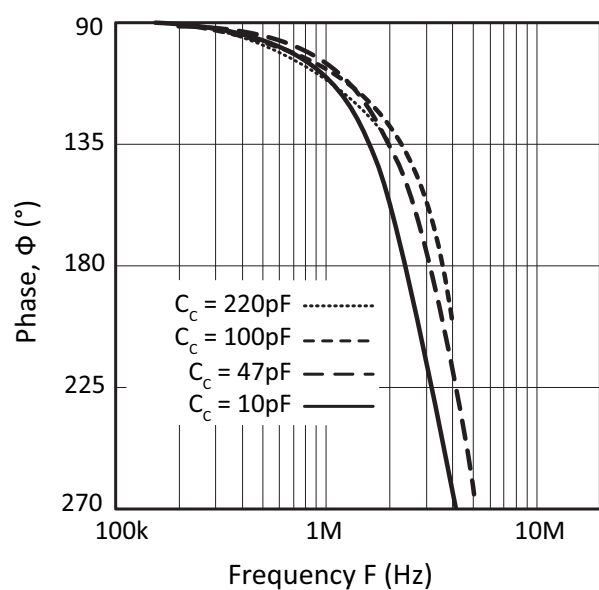

Figure 8: Output Voltage Swing

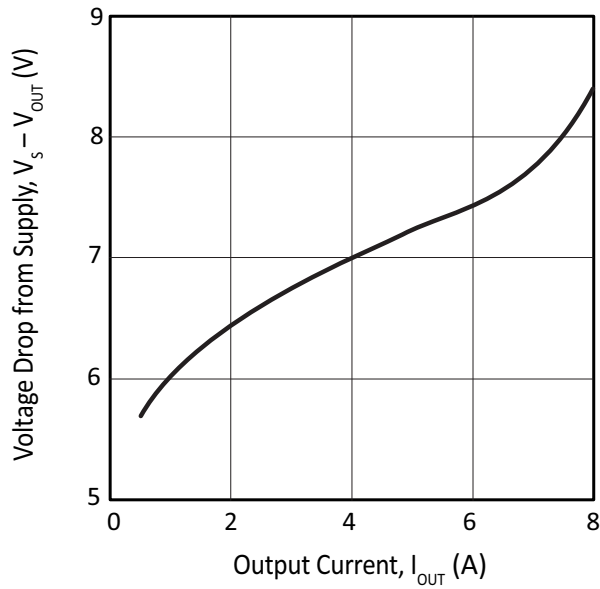

Figure 9: Power Response

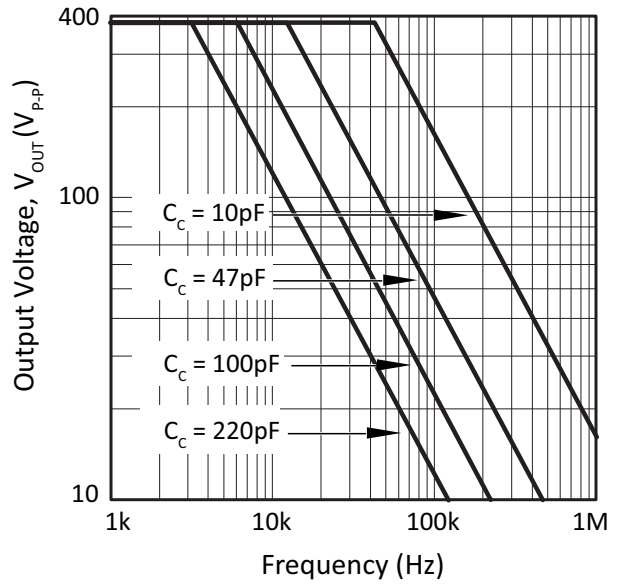

Figure 10: Slew Rate

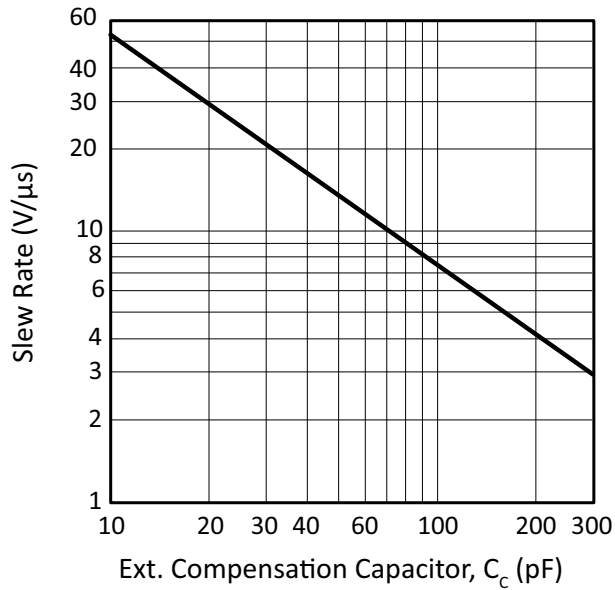

Figure 11: Harmonic Distortion

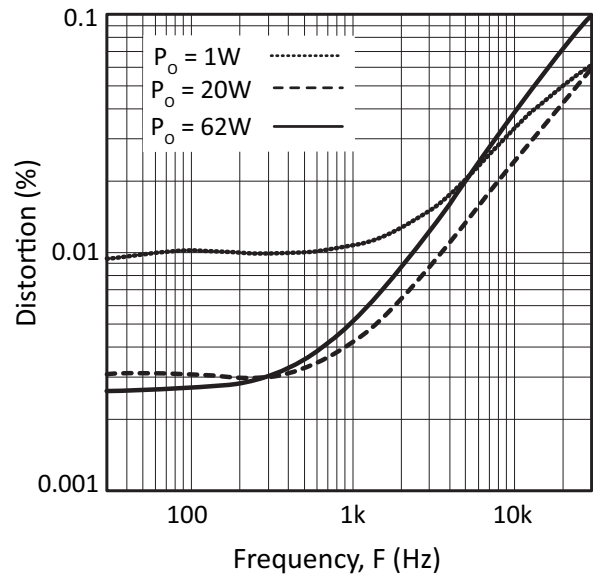

Figure 12: Input Noise Voltage

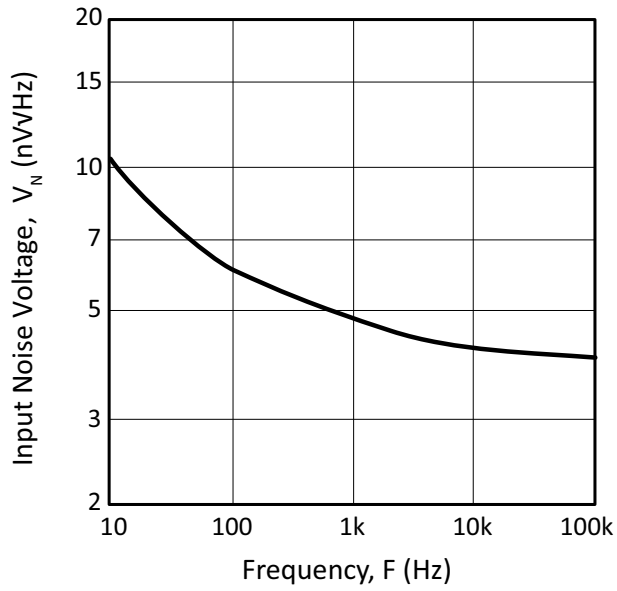
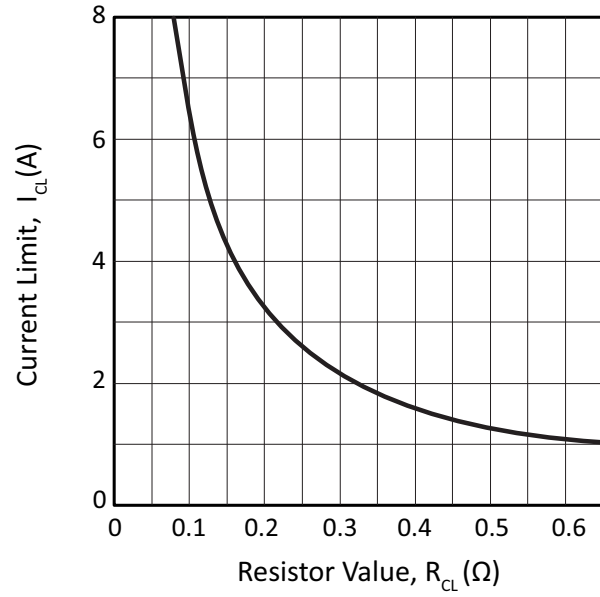

Figure 13: Current Limit



SAFE OPERATING AREA (SOA)

The safe operating area curves define the maximum additional internal power dissipation the amplifier can tolerate when it produces the necessary output to drive an external load.

The MOSFET output stage of this power operational amplifier has two distinct limitations:

1. The current handling capability of the MOSFET geometry and the wire bonds.
2. The junction temperature of the output MOSFETs.

Note: The output stage is protected against transient flyback. However, for protection against sustained, high energy flyback, external fast-recovery diodes should be used.

Figure 14: SOA

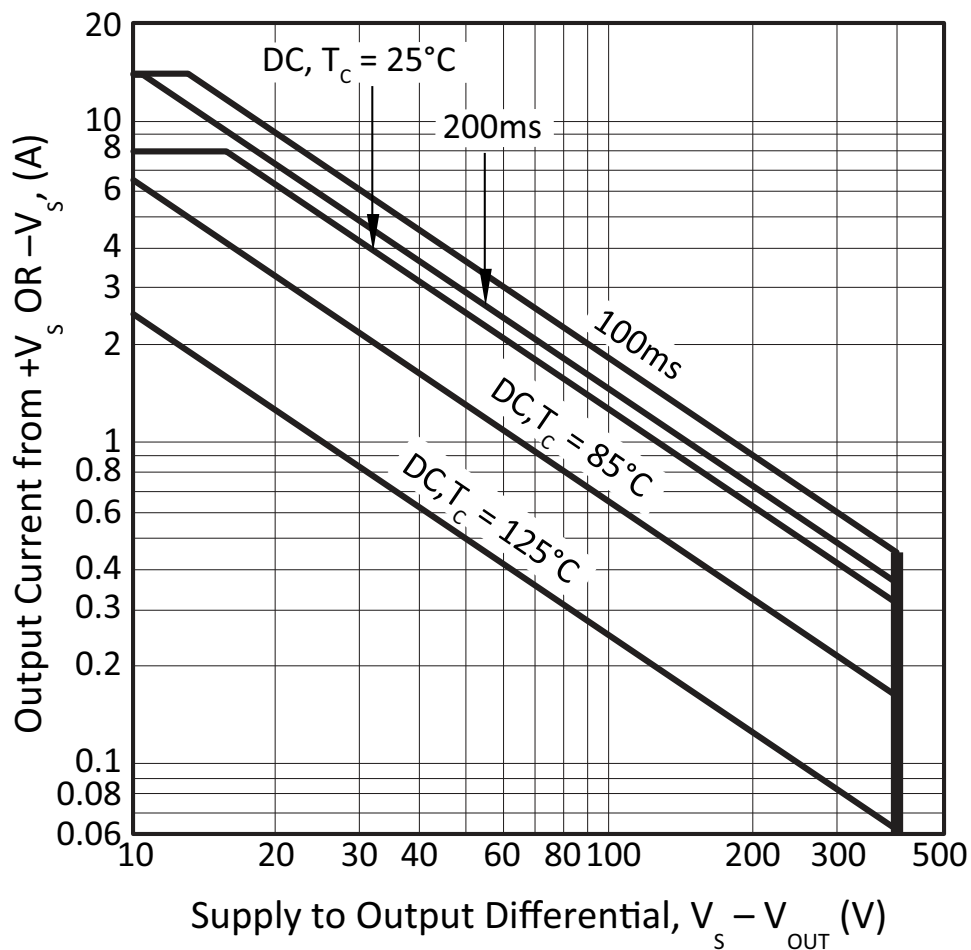

GENERAL

Please read Application Note 1 “General Operating Considerations” which covers stability, supplies, heat sinking, mounting, current limit, SOA interpretation, and specification interpretation. Visit www.apexanalog.com for Apex Microtechnology’s complete Application Notes library, Technical Seminar Workbook, and Evaluation Kits.

TYPICAL APPLICATION

LOW POWER, PIEZOELECTRIC POSITIONING

Piezo positioning may be applied to the focusing of segmented mirror systems. The composite mirror may be composed of hundreds of elements, each requiring focusing under computer control. In such complex systems the PA93 reduces the costs of power supplies and cooling with its advantages of low cost and low quiescent power consumption while increasing circuit density with the SIP package.

Figure 15: Typical Application

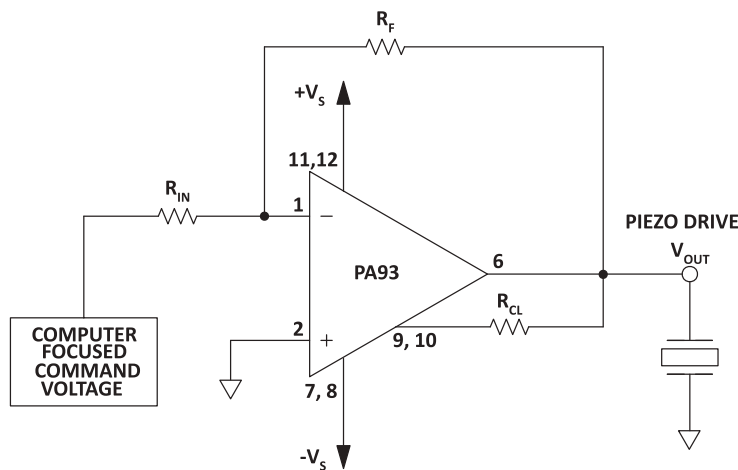

PHASE COMPENSATION

Gain	C _C *	R _C
≥1	220pF	100 Ω
≥2	100pF	100 Ω
≥4	47pF	0 Ω
≥17	10pF	0 Ω

*C_C Never to be <10pF. C_C to be rated for the full supply voltage +V_S to -V_S. Use ceramic NPO (COG) type.

STABILITY

The PA93 is externally compensated and performance can be tailored to the application. Use the graphs of small signal response and power response as a guide. The compensation capacitor C_C must be rated at 500V working voltage. An NPO capacitor is recommended. The compensation network C_CR_C must be mounted closely to the amplifier pins 4 and 5 to avoid spurious oscillation.

CURRENT LIMIT

For proper operation, the current limit resistor (R_{CL}) must be connected as shown in the external connection diagram. For optimum reliability the resistor value should be set as high as possible. The value is calculated as follows; with the maximum practical value of 16 ohms.

$$R_{CL}(\Omega) = \frac{0.65V}{I_{CL}(A)}$$

INPUT PROTECTION

Although the PA93 can withstand differential voltages up to $\pm 20V$, additional external protection is recommended. Low leakage, low capacitance JFETs connected as diodes are recommended (e.g. 2N4416, Q1-Q4 in Figure 16). The differential input voltage will be clamped to $\pm 1.4V$. This is sufficient overdrive to produce maximum power bandwidth.

POWER SUPPLY PROTECTION

Unidirectional zener diode transient suppressors are recommended as protection on the supply pins. See Figure 16. The zeners clamp transients to voltages within the power supply rating and also clamp power supply reversals to ground. Whether the zeners are used or not, the system power supply should be evaluated for transient performance including power-on overshoot and power-off polarity reversals as well as line regulation.

Conditions which can cause open circuits or polarity reversals on either power supply rail should be avoided or protected against. Reversals or opens on the negative supply rail is known to induce input stage failure. Unidirectional transzorbis prevent this, and it is desirable that they be both electrically and physically as close to the amplifier as possible.

Figure 16: Over voltage Protection

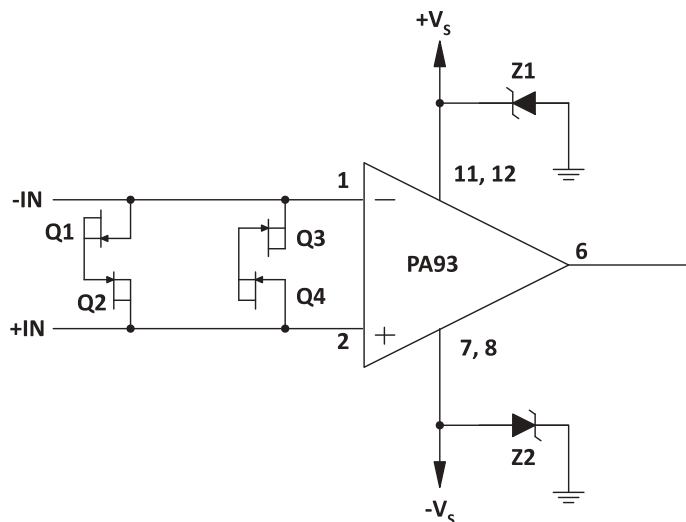

QUIESCENT CURRENT REDUCTION

When pin 3 (I_Q) is shorted to pin 5 (CC2) the AB biasing of the output stage is disabled. This lowers quiescent power but also raises distortion since the output stage is then class C biased. The output stage bias current is nominally set at 1mA. Pin 3 may be left open if not used.

PACKAGE STYLE EE

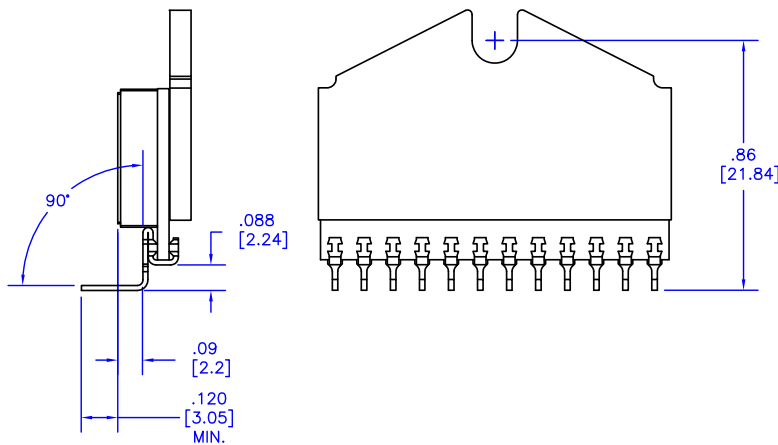
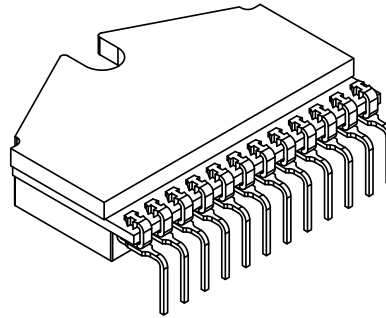

NOTES:

1. Dimensions are inches & [mm].
2. For other dimensions and information on this package with unformed leads, see package DP.

NEED TECHNICAL HELP? CONTACT APEX SUPPORT!

For all Apex Microtechnology product questions and inquiries, call toll free 800-546-2739 in North America. For inquiries via email, please contact apex.support@apexanalog.com. International customers can also request support by contacting their local Apex Microtechnology Sales Representative. To find the one nearest to you, go to www.apexanalog.com

IMPORTANT NOTICE

Apex Microtechnology, Inc. has made every effort to insure the accuracy of the content contained in this document. However, the information is subject to change without notice and is provided "AS IS" without warranty of any kind (expressed or implied). Apex Microtechnology reserves the right to make changes without further notice to any specifications or products mentioned herein to improve reliability. This document is the property of Apex Microtechnology and by furnishing this information, Apex Microtechnology grants no license, expressed or implied under any patents, mask work rights, copyrights, trademarks, trade secrets or other intellectual property rights. Apex Microtechnology owns the copyrights associated with the information contained herein and gives consent for copies to be made of the information only for use within your organization with respect to Apex Microtechnology integrated circuits or other products of Apex Microtechnology. This consent does not extend to other copying such as copying for general distribution, advertising or promotional purposes, or for creating any work for resale.

APEX MICROTECHNOLOGY PRODUCTS ARE NOT DESIGNED, AUTHORIZED OR WARRANTED TO BE SUITABLE FOR USE IN PRODUCTS USED FOR LIFE SUPPORT, AUTOMOTIVE SAFETY, SECURITY DEVICES, OR OTHER CRITICAL APPLICATIONS. PRODUCTS IN SUCH APPLICATIONS ARE UNDERSTOOD TO BE FULLY AT THE CUSTOMER OR THE CUSTOMER'S RISK.

Apex Microtechnology, Apex and Apex Precision Power are trademarks of Apex Microtechnology, Inc. All other corporate names noted herein may be trademarks of their respective holders.

Looking for pricing, stock, or lifecycle information?

Click below to explore more details on WIN SOURCE:

- [View PA93 on WIN SOURCE](#)
- [Apex Microtechnology Information](#)

Optimize Your Supply Chain with WIN SOURCE Solutions

- ✓ Global Sourcing Solution
- ✓ Obsolete Management
- ✓ Cost Control Management
- ✓ Shortage Management
- ✓ Alternative Solution
- ✓ Excess Inventory Management